

Release Protective Cover Locks Using Controller Signals or Pushbutton Switches after the Cutting Tool Stops Moving Due to Inertia

Note: Contact your sales representative for details on models with safety standard certification.



- A mechanical lock is applied automatically when the Operation Key is inserted. A high level of safety is achieved using a mechanism where the lock is only released when voltage is applied to the solenoid.
- Conforms to EN (TÜV) standards corresponding to the CE marking.
- Certified by UL, CSA and CCC standards.
- The Switch contact is opened by a direct opening mechanism (NC contacts only) when the protective cover is opened. Direct opening mechanism that is EN-certified is indicated by  on the Switch.
- Auxiliary release key ensures easy maintenance and unlocks the door in the case of a power failure.
- Tough aluminum die-cast body incorporating a switch box with degree of protection satisfying IP67, UL, and CSA TYPE6P, 13.
- Equipped with a horizontal and vertical conduit opening.
- Models incorporating easy-to-see indicators for monitoring and those using an adjustable Operation Key for a swinging door are available.
- The mounting direction of the head can be changed to allow the Operation Key to be inserted from four directions.



 Be sure to read the "Safety Precautions" on page 13.

Model Number Structure

Model Number Legend

Switch

D4BL - \square ₁ \square ₂ \square ₃ \square ₄ - \square ₅

- 1. Conduit Size (2-conduit)**
 - 1: PG13.5
 - 2: G1/2
 - 4: M20
- 2. Built-in Switch (with Safety Switch and Lock Monitor Switch Contacts)**
 - C: 1NC/1NO (slow-action) + 1NC (slow-action)
 - D: 2NC (slow-action) + 1NC (slow-action)
- 3. Head Mounting Direction**
 - R: Four mounting directions possible (right-side mounting at shipping)
- 4. Door Lock and Release (Auxiliary Release Key is Incorporated by All Models)**
 - A: Mechanical lock/24 VDC solenoid release
 - G: 24 VDC Solenoid lock/Mechanical release
- 5. Indicator**
 - Blank: Without indicator
 - A: 10 to 115 VAC or VDC driving (with orange and green LED indicator unit)

Operation Key

D4BL - K \square ₁

- 1. Operation Key Type**
 - 1: Horizontal mounting
 - 2: Vertical mounting
 - 3: Adjustable mounting (Horizontal)

Switch

D4BL -2GRD-AT
 1 2 3 4 5

1. **Conduit Size (2-conduit)**
 2: G1/2
2. **Built-in Switch**
 G: 2NC (slow-action) + 2NC (slow-action)
3. **Head Mounting Direction**
 R: Four mounting directions possible (right-side mounting at shipping)
4. **Door Lock and Release**
 D: Mechanical lock/24 VDC solenoid release
5. **Indicator lamp**
 A: Equipped with an orange/green LED display unit

Operation Key

D4BL - K 
 1

1. **Operation Key Type**
 - 1: Horizontal mounting
 - 2: Vertical mounting
 - 3: Adjustable mounting (Horizontal)

Ordering Information

List of Models



Switches (Operation Keys are sold separately.)

: Models with certified direct opening contacts.

Consult with your OMRON representative when ordering any models that are not listed in this table.

Lock method	Conduit size	Voltage for solenoid	Without indicator 1NC/1NO+ 1NC (Slow-action)	With LED indicator 1NC/1NO+ 1NC (Slow-action)	Without indicator 2NC+ 1NC (Slow-action)	With LED indicator 2NC+ 1NC (Slow-action)
Mechanical lock	PG13.5	24 VDC	D4BL-1CRA	D4BL-1CRA-A	D4BL-1DRA	D4BL-1DRA-A
	G1/2		D4BL-2CRA	D4BL-2CRA-A	D4BL-2DRA	D4BL-2DRA-A
	M20		D4BL-4CRA	D4BL-4CRA-A	D4BL-4DRA	D4BL-4DRA-A
Solenoid lock	Pg 13.5	24 VDC	D4BL-1CRG	D4BL-1CRG-A	D4BL-1DRG	D4BL-1DRG-A
	G1/2		D4BL-2CRG	D4BL-2CRG-A	D4BL-2DRG	D4BL-2DRG-A
	M20		D4BL-4CRG	D4BL-4CRG-A	D4BL-4DRG	D4BL-4DRG-A

Operation Keys

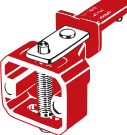
Mounting type	Model
Horizontal mounting 	D4BL-K1
Vertical mounting 	D4BL-K2
Adjustable mounting 	D4BL-K3

Specifications

Standards and EC Directives

Conforms to the following EC Directives:

- Machinery Directive
- Low Voltage Directive
- EN1088

Certified Standards

Certification body	Standard	File No.
TÜV Rheinland	EN60947-5-1 (certified direct opening) GS-ET-19	R9451050
UL	UL508	E76675
CSA	CSA C22.2, No.14	LR45746
CQC (CCC)	GB14048.5	2003010305073836

Certified Standard Ratings

TÜV (EN60947-5-1), CCC (GB14048.5)

Item	Type	Standard model	Indicator model
Utilization category		AC-15	AC-15
Rated operating current (I _e)		3 A	6 A
Rated operating voltage (U _e)		250 V	115 V

Note: Use a 10 A fuse type gI or gG that conforms to IEC60269 as a short-circuit protection device.

UL/CSA (UL508, CSA C22.2 No. 14)

A300

Rated voltage	Carry current	Current (A)		Volt-amperes (VA)	
		Make	Break	Make	Break
120 VAC	10 A	60	6	7,200	720
240 VAC		30	3		

Note: The UL/CSA certified rating for products with indicators (-A) is 6 A/115 VAC.

Characteristics

Degree of protection *1		IP67 (EN60947-5-1)
Durability *2	Mechanical	1,000,000 operations min.
	Electrical	500,000 operations min. (10 A resistive load at 250 VAC)
Operating speed		0.05 to 0.5 m/s
Operating frequency		30 operations/minute max.
Direct opening force *3		19.61 N min. (EN60947-5-1)
Direct opening travel *3		20 mm min. (EN60947-5-1)
Holding force		700 N min. (GS-ET-19)
Contact resistance		50 mΩ max.
Rated insulation voltage (U _i)		300 V (EN60947-5-1)
Rated frequency		50/60 Hz
Protection against electric shock		Class I (with ground terminal)
Pollution degree (operating environment)		3 (EN60947-5-1)
Impulse withstand voltage (EN60947-5-1)	Between terminals of same polarity	4 kV
	Between terminals of different polarity	
	Between each terminal and ground	
	Between solenoid and ground	2.5 kV
Insulation resistance		100 MΩ min. (at 500 VDC)
Contact gap		2 × 2 mm min.
Vibration resistance	Malfunction	10 to 55 Hz, 0.35 mm single amplitude
Shock resistance	Destruction	1,000 m/s ² min.
	Malfunction	300 m/s ² min.
Conditional short-circuit current		100 A (EN60947-5-1)
Conventional enclosed thermal current (I _{the})		10 A (EN60947-5-1)
Ambient operating temperature		-10 to 55°C (with no icing)
Ambient operating humidity		95% max.
Weight		Approx. 800 g

Note: The above values are initial values.

*1. The degree of protection is tested using the method specified by the standard (EN60947-5-1). Confirm that sealing properties are sufficient for the operating conditions and environment beforehand. Although the switch box is protected from dust, oil or water penetration, do not use the D4BL in places where dust, oil, water, or chemicals may enter through the key hole on the head, otherwise Switch damage or malfunctioning may occur.

*2. The durability is for an ambient temperature of 5 to 35°C and an ambient humidity of 40% to 70%.

*3. These figures are minimum requirements for safe operation.

Solenoid Coil Characteristics

Item	Type	24 VDC mechanical lock models	24 VDC solenoid lock models
Rated operating voltage		24 VDC ^{+10%} / _{-15%} (100% ED)	
Current consumption		Approx. 300 mA	
Insulation class		Class B (130°C or less)	

Indicator Characteristics

Rated voltage	10 to 115 VAC/VDC
Current leakage	Approx. 1 mA
Color (LED)	Orange, green

Structure and Nomenclature

Structure

D4BL-□CR□-□

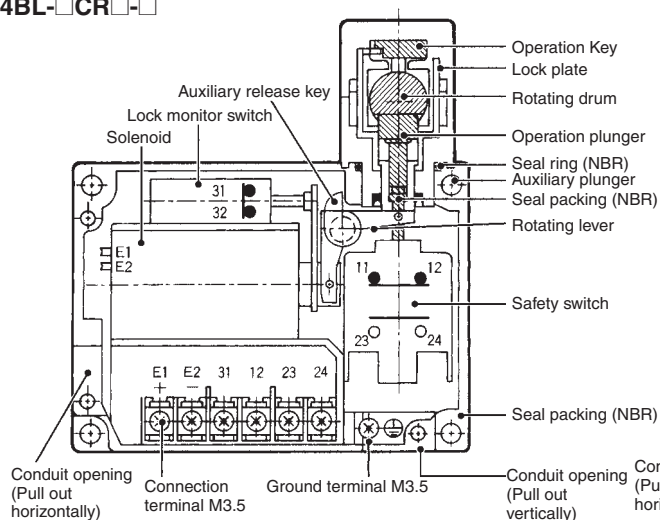

D4BL-□DR□-□

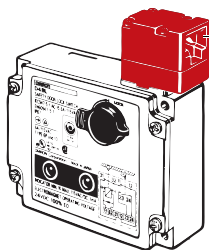
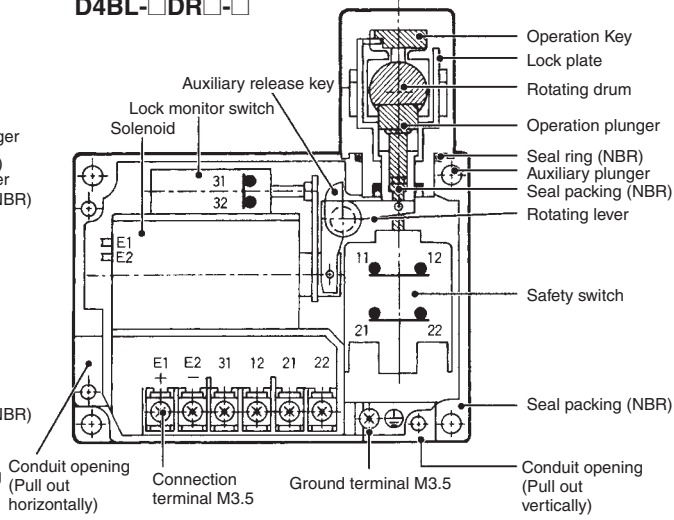

The head can be changed to any of four directions.

Contact Form (Diagrams Show State with Key Inserted and Lock Engaged)

Model	Contact (door open/closed detection and lock monitor)	Contact form		Operating pattern	Remarks
		Lock monitor	Door open/closed detection		
D4BL-□CR□-□	1NC/1NO+1NC				<p>Only NC contacts 11-12 have a certified direct opening mechanism. (⊕)</p> <p>The terminals 11-12 and 23-24 can be used as unlike poles.</p>
D4BL-□DR□-□	2NC+1NC				<p>Only NC contacts 11-12 and 21-22 have a certified direct opening mechanism. (⊕)</p> <p>The terminals 11-12 and 21-22 can be used as unlike poles.</p>

Note: The EN-certified direct opening mechanism is indicated by (⊕) on the Switch.

Contact Form (D4BL-2GRD-AT)

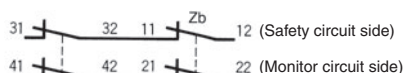

Dimensions and Operating Characteristics

Switches

D4BL-□□R□-□

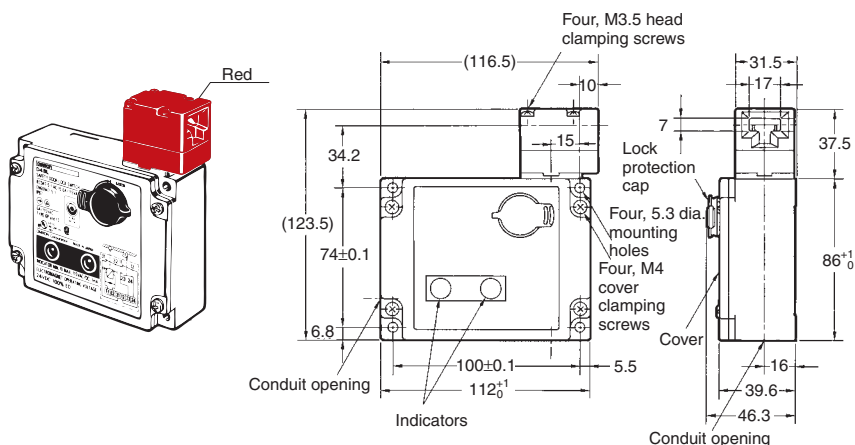

Operating Characteristics	Model	D4BL-□□R□-□
Key insertion force		19.61 N max.
Key extraction force		19.61 N max.
Movement before being locked		15 mm max.
Total travel		23 mm min.

D4BL-2GRD-AT

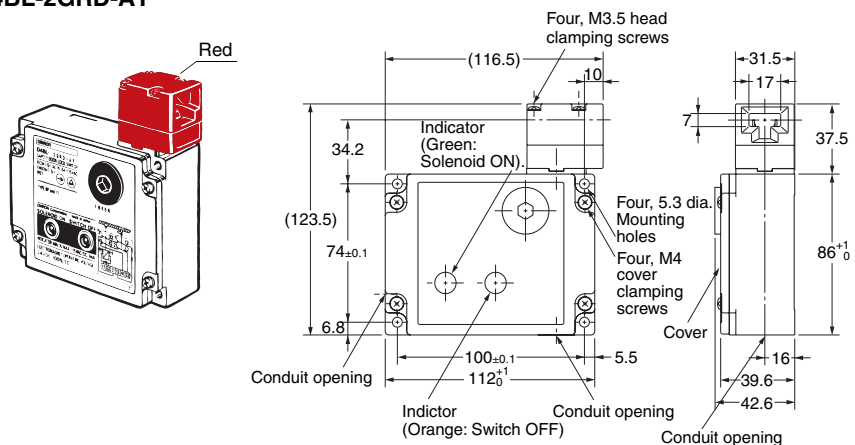

Operating Characteristics	Model	D4BL-2GRD-AT
Key insertion force		19.61 N max.
Key extraction force		19.61 N max.
Movement before being locked		15 mm max.
Total travel		23 mm min.

- Note:**
1. Unless otherwise specified, a tolerance of ± 0.4 mm applies to all dimensions.
 2. There are fluctuations in the contact ON/OFF timing for 2NC contacts. Confirm performance before application.

Operation Keys

D4BL-K1

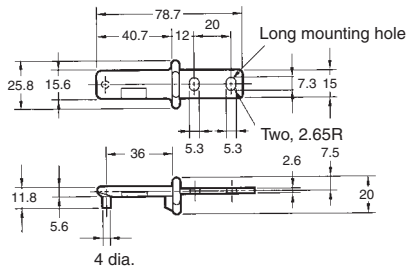
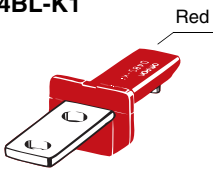

D4BL-K3

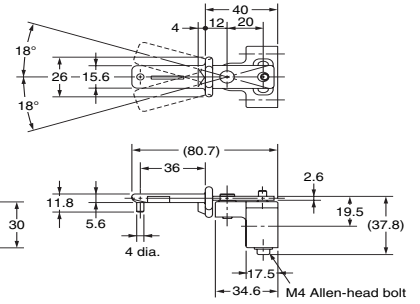
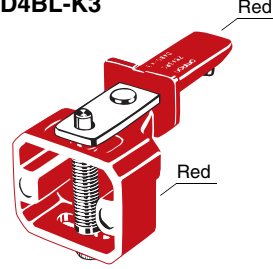

D4BL-K2

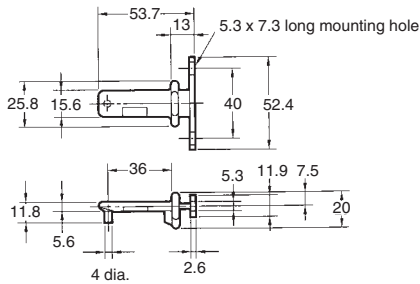
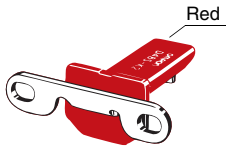

With Operation Key Inserted

D4BL + D4BL-K1

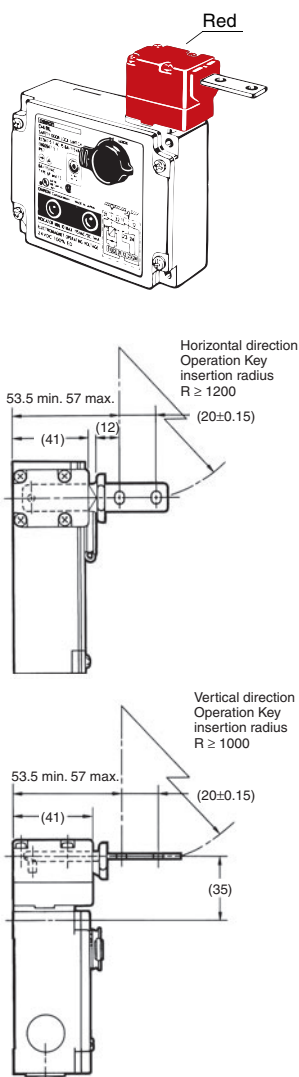

D4BL + D4BL-K2

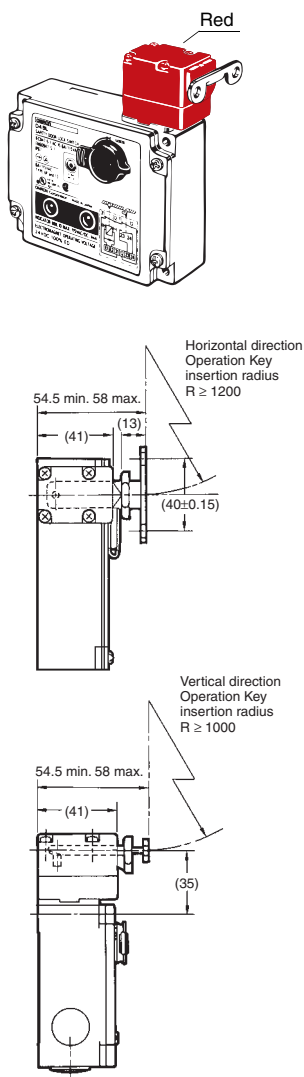

D4BL + D4BL-K3

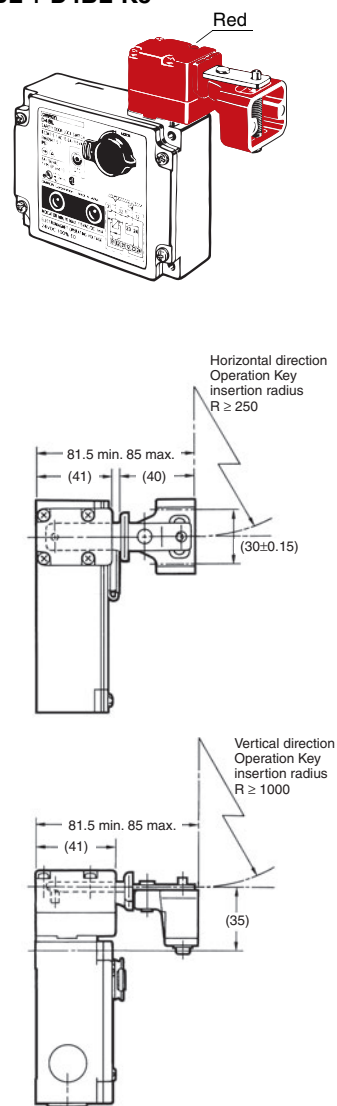

Note: 1. Unless otherwise specified, a tolerance of ± 0.4 mm applies to all dimensions.
2. In the above diagrams, the Operation Key is inserted from the front.

Indicator Unit

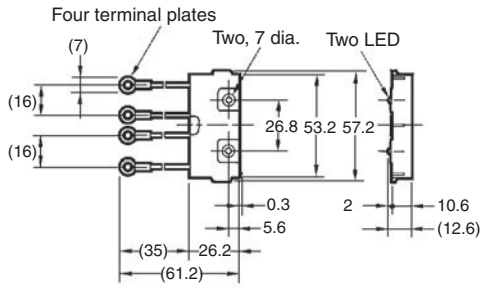

Connections

Internal Circuit Diagram

Indicator

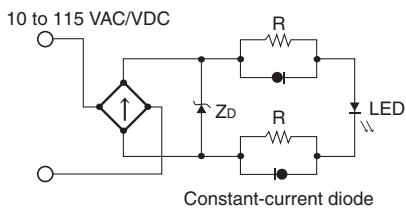

Solenoid

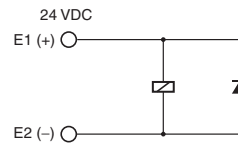

Circuit Connection Example

- Terminals 11 and 32 are connected internally and so connect terminals 12 and 31 for safety-circuit input. (GS-ET-19).
- When using indicators, connect them to the auxiliary circuit side (monitor circuit) or in parallel between E1 and E2 as shown below.
- Do not connect the indicators in parallel with the direct opening contact. If the indicators are broken, a short-circuit current may flow, causing equipment to malfunction.
- The 24 VDC solenoid terminals have polarity. Confirm the polarity before wiring.

1. Orange: Lights when the solenoid turns ON. Green: Lights when the door opens.

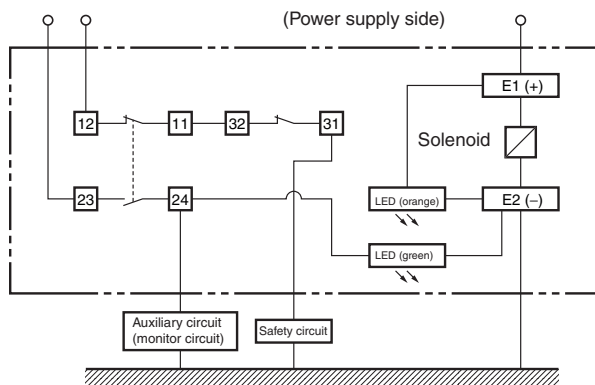

2. Orange: Lights when the solenoid turns ON. Green: Lights when power turns ON.

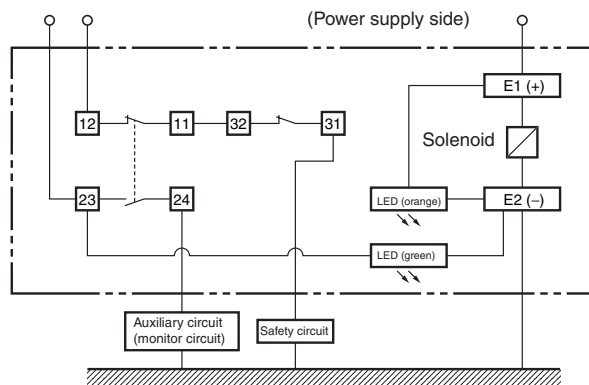

3. Orange: Lights when the solenoid turns ON. Green: Lights when door closes.

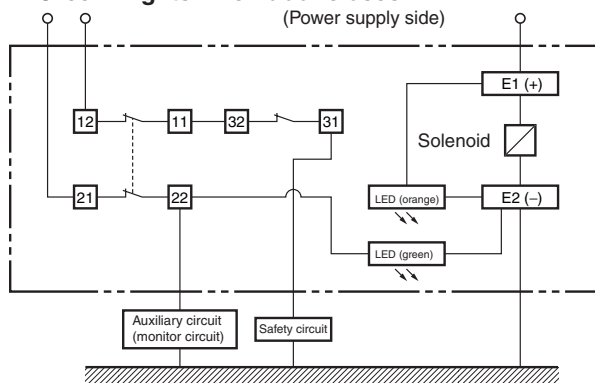

4. Orange: Lights when the solenoid turns ON. Green: Lights when power turns ON.

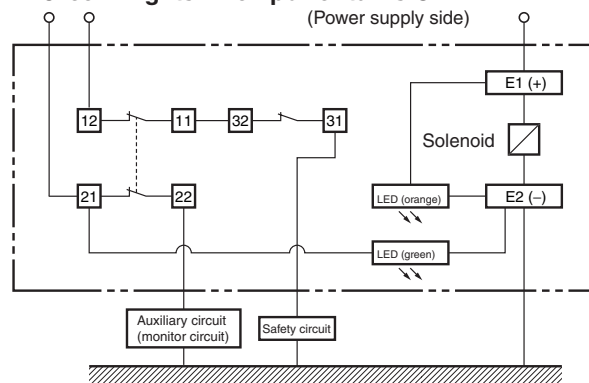

Connection Example with OMRON's G9SA Safety Relay Unit

G9SA-321-T (24 VAC/VDC) + D4BL-DRA (Mechanical Lock Type) Circuit Diagram (Manual Reset)

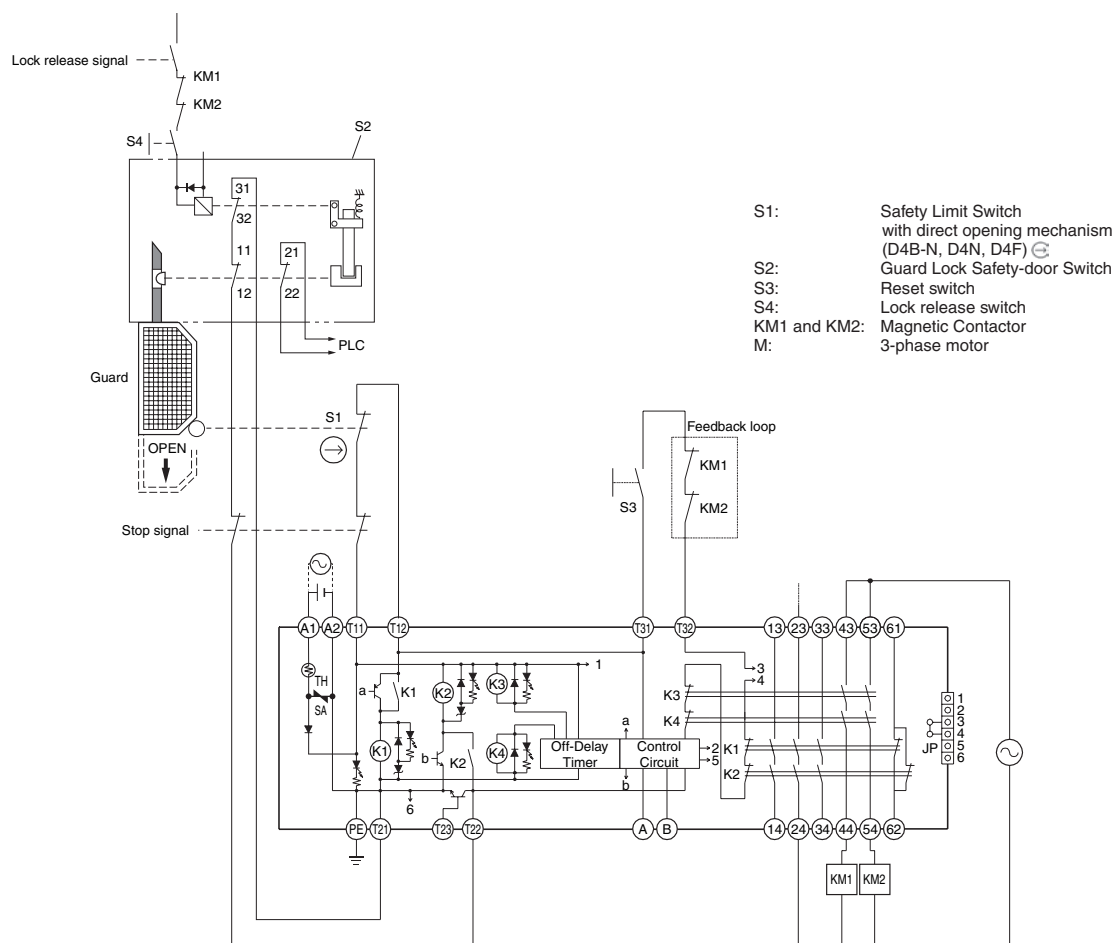

- S1: Safety Limit Switch with direct opening mechanism (D4B-N, D4N, D4F)
- S2: Guard Lock Safety-door Switch
- S3: Reset switch
- S4: Lock release switch
- KM1 and KM2: Magnetic Contactor
- M: 3-phase motor

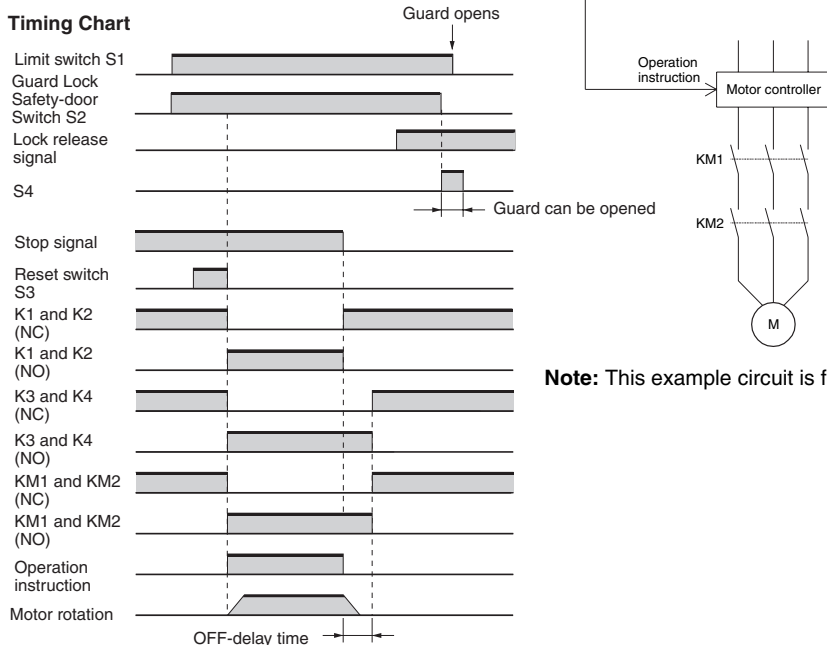

Note: This example circuit is for Category 3.

G9SA-301 (24 VAC/VDC) + D4BL-□DRG-□ (Solenoid Lock Type) Circuit Diagram (Auto-reset)

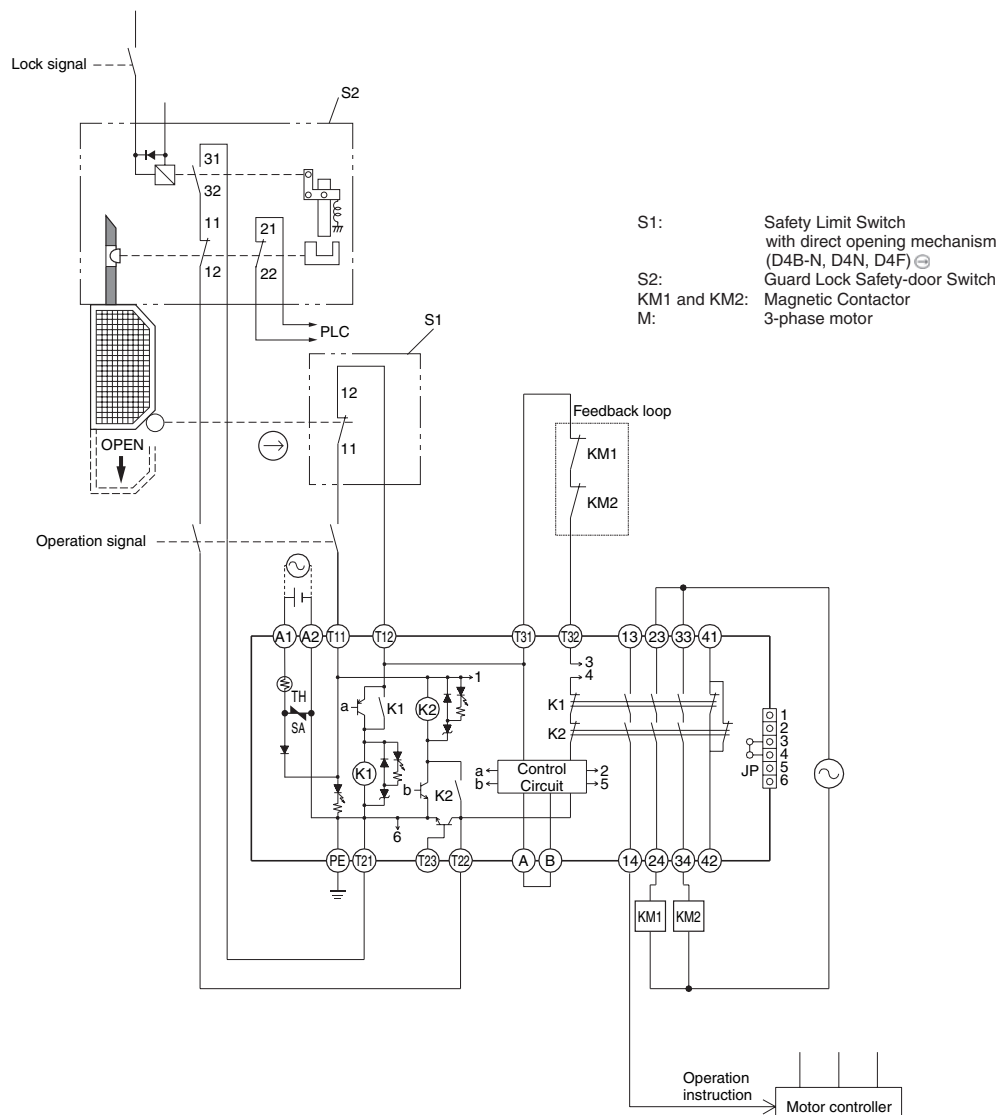

S1: Safety Limit Switch with direct opening mechanism (D4B-N, D4N, D4F) ⊕
 S2: Guard Lock Safety-door Switch
 KM1 and KM2: Magnetic Contactor
 M: 3-phase motor

Timing Chart

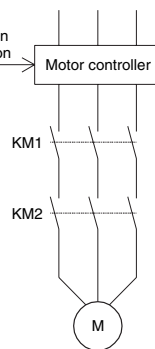
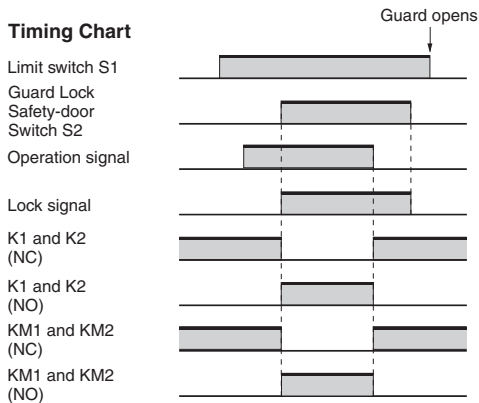

Note: 1. This example circuit is for Category 4.
 2. The lock can be released at any time. Therefore, do not use a model with a solenoid lock in applications where the operator may be exposed to danger when the guard opens. Use a model with a mechanical lock.

Safety Precautions

- Be sure to read the precautions for all D4BL models in the website at: <http://www.ia.omron.com/>.

DANGER

Injury may occasionally occur. Always check to make sure that the safety functions operate correctly before using the machine. The safety functions may not operate correctly because of wiring mistakes, setting mistakes, or Switch malfunction, causing some machines to continue operating in situations where they should be stopped.



Injury may occasionally occur. If the machine is used with the release key in the UNLOCK position, the electromagnetic lock may not operate, causing some machines to continue operating in situations where they should be stopped. Be sure to put the release key in the LOCK position before using the machine. Also, check the condition of the lock and safety circuits.



Injury may occasionally occur. When the electromagnetic lock function or Switch function is damaged, some machines may continue operating in situations where they should be stopped. Do not use the electromagnetic lock function of the Switch in place of a door lock. Always provide a lock separate from the Switch, attach a warning seal to prevent people from using excessive force to open the door when it is locked, or provide an indicator lamp to show the locked/unlocked status of the door.



Precautions for Safe Use

- Do not use the Switch submerged in oil or water or in locations continuously subject to splashes of oil or water. Doing so may result in oil or water entering the Switch. (The IP67 degree of protection of the Switch specifies the amount of water penetration after the Switch is submerged in water for a certain period of time.)
- Always attach the cover after completing wiring and before using the Switch. Also, do not turn ON the Switch with the cover open. Doing so may result in electric shock.
- Make sure the Switch is mounted securely to prevent it from falling off. Otherwise injury may result.

Stopper Installation

Do not use a Switch as a stopper. Be sure to install a stopper as shown in the following illustration when mounting the Switch so that the Operation Key is within 0.5 to 5 mm of the set zone. Do not subject the Switch to a shock that exceeds the Switch's shock resistance of 1,000 m/s².

Correct

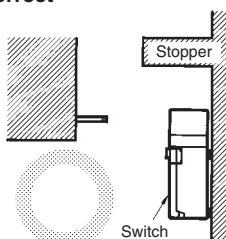

Incorrect

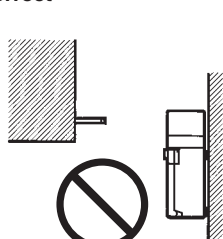

Incorrect

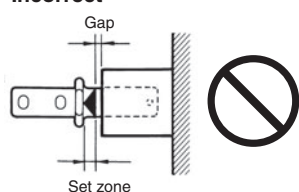

Correct

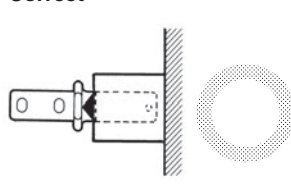

Precautions for Correct Use

Appropriate Tightening Torque

Loose screws may result in malfunction. Tighten the screws to the specified torques.

No.	Type	Appropriate tightening torque
1	M3.5 terminal screw (including terminal screw)	0.59 to 0.78 N·m
2	Cover mounting screw	1.18 to 1.37 N·m
3	Head mounting screw	0.78 to 0.98 N·m
4	M5 body mounting screw *	4.90 to 5.88 N·m
5	Operation Key mounting screw	2.35 to 2.75 N·m
6	Connector	1.77 to 2.16 N·m
7	Cap screw	1.27 to 1.67 N·m

* Use M5 screws. Apply a torque of 4.90 to 5.88 N·m for an Allen-head bolt. For a pan head screw, apply a torque of 2.35 to 2.75 N·m

5. Two, M5 Operation Key mounting screw

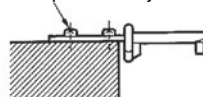

3. Four, M3.5 head-mounting screw

2. Four, M4 cover-mounting screw

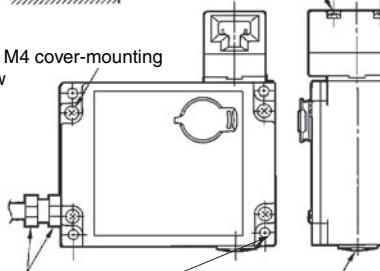

6. Conduit

4. Four, M5 switch-mounting screw

7. Conduit cap

Auxiliary Release Key

- The auxiliary release key is used to unlock the D4BL in case of emergency or in case the power supply to the D4BL fails.
- Use the enclosed Release Key to change the lock from LOCK to UNLOCK so that the lock will be released and the door can be opened. (Applies only to mechanical locks. Release key is not provided with D4BL-2GRD-AT.)

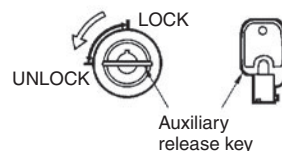

- Whenever the lock has been changed to UNLOCK, always return it to LOCK before using the Switch.
- Do not use the auxiliary release key to start or stop machines.
- Make sure that the auxiliary release key is kept with the person in charge.
- To prevent the auxiliary release key from being handled carelessly by unauthorized people, seal the auxiliary release key with sealing wax and the provided seal cap to ensure IP67.
- Before attaching the cover to the D4BL, make sure that the auxiliary release key position is set to LOCK.

Solenoid Lock Models

The solenoid lock locks the door only when power is supplied to the solenoid. Therefore, the door will be unlocked if the power supply to the solenoid stops. Therefore, do not use solenoid lock models for machines that may be operating and dangerous even after the machine stops operating.

Switch and Operation Key Mounting

Use four M5 screws and spring washers to mount the Switch and Operation Key, and tighten the screws to a suitable torque. To ensure safety, use screws that cannot be easily removed or another means to prevent the Switch and Operation Key from easily being removed.

Mounting Dimensions

Switch Mounting Dimensions

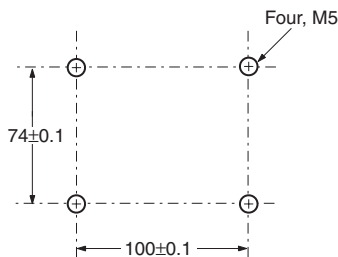

Operation Key Mounting Holes

D4BL-K1

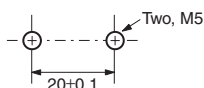

D4BL-K2

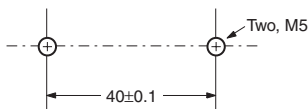

D4BL-K3

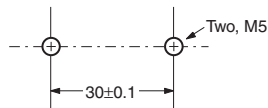

Operation Key

- The D4BL is provided with a shock-absorbing damper to protect the D4BL from damage that may result from dropping the D4BL during transportation. Be sure to remove the damper after mounting the D4BL.
- The mounting tolerance of the Operation Key is ± 0.3 mm vertically or horizontally. Be sure to mount the D4BL correctly without misalignment, otherwise the D4BL may soon break or wear out.
- Observe the specified insertion radius for the Operation Key and insert it in a direction perpendicular to the key hole.

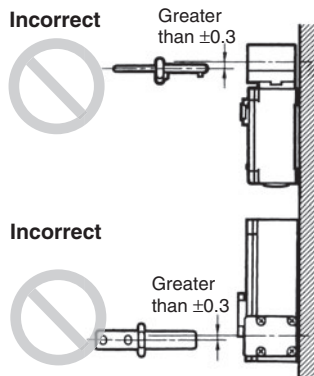

- Do not use the D4BS operation key.

Head Direction

- The head can be mounted in four directions by loosening the four screws holding the head. To remove the head, turn the head at the surface mating with the Switch body by 45° as shown in figures (A) and (B) below.

To change the direction of the head, make sure that the protruding part of the rotating lever engages with the groove of the plunger. Then turn the head clockwise or counterclockwise to the desired direction. At that time, make sure that the groove of the plunger is located under the rotating lever. If the direction of the head is not set when the plunger is rotated by 45° , the groove of the plunger presses the rotating lever. The head, plunger, or the built-in switch may be damaged as a result.

Head Direction Changes

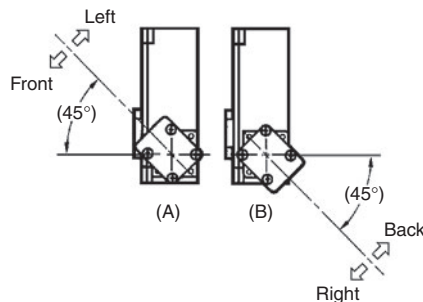

Head Bottom View

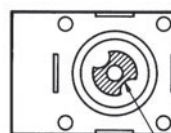

Operation plunger and groove mechanism

Switch Top View

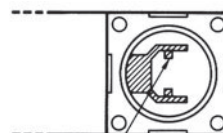

Rotation lever and protruding part

Normal Positions of Rotating Lever and Plunger

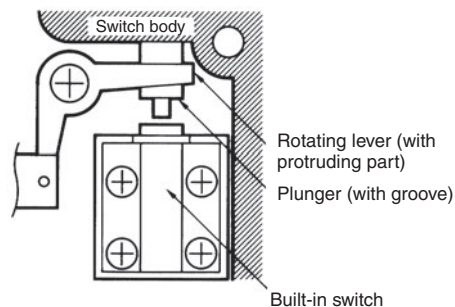

- Be sure to check the mechanical lock and solenoid release functions when mounting the D4BL.
- If the head direction is changed, recheck the tightening torque of each of screw. Make sure that no foreign materials will enter through the key hole on the head.

Processing and Connecting Cable/Conduit

- The following procedures are recommended for mounting and wiring the indicator unit securely.
- To ensure IP67, use OMRON's SC-□M and Nippon Flex's ABS-08Pg13.5 and ABS-12 Pg13.5 Connectors.
- Recommended cable: UL2464-type cable that is AWG20 to AWG18 (0.5 to 1.0 mm²) in size and has seven conductors
- Connect the indicator unit after connecting the seven-conductor cable.

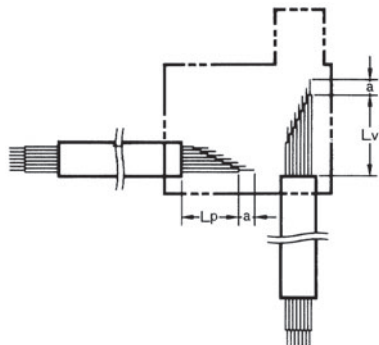

Terminal no.	Lp (mm)	Lv (mm)	a (mm)
E ₁	30±2	80±2	8±1
E ₂	35±2	75±2	
31	45±2	60±2	
12	55±2	50±2	
23 (21)	65±2	45±2	
24 (22)	70±2	35±2	
⊖	90±2	50±2	

- Properly attach and securely tighten the provided conduit cap to the unused conduit opening to the suitable tightening torque when wiring the D4BL.

Cable Connection Example

1. Connect the wires to the terminals in the order shown below for wiring efficiency.

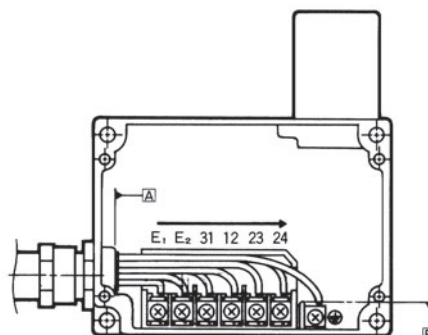

Tighten each wired terminal clockwise to a torque of 0.59 to 0.78 N·m.

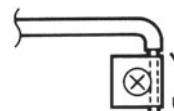

Twist the wire two or three times and make sure that no bare wire exists outside the terminal when tightening the terminal.

2. The insulation sheath of the seven-conductor cable must come into contact with the wall of the conduit mouth, side A or side B.

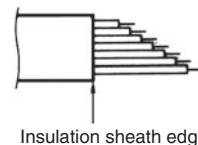

Others

Do not touch the solenoid because the solenoid radiates heat while power is being supplied.

Read and Understand This Catalog

Please read and understand this catalog before purchasing the products. Please consult your OMRON representative if you have any questions or comments.

Warranty and Limitations of Liability

WARRANTY

OMRON's exclusive warranty is that the products are free from defects in materials and workmanship for a period of one year (or other period if specified) from date of sale by OMRON.

OMRON MAKES NO WARRANTY OR REPRESENTATION, EXPRESS OR IMPLIED, REGARDING NON-INFRINGEMENT, MERCHANTABILITY, OR FITNESS FOR PARTICULAR PURPOSE OF THE PRODUCTS. ANY BUYER OR USER ACKNOWLEDGES THAT THE BUYER OR USER ALONE HAS DETERMINED THAT THE PRODUCTS WILL SUITABLY MEET THE REQUIREMENTS OF THEIR INTENDED USE. OMRON DISCLAIMS ALL OTHER WARRANTIES, EXPRESS OR IMPLIED.

LIMITATIONS OF LIABILITY

OMRON SHALL NOT BE RESPONSIBLE FOR SPECIAL, INDIRECT, OR CONSEQUENTIAL DAMAGES, LOSS OF PROFITS OR COMMERCIAL LOSS IN ANY WAY CONNECTED WITH THE PRODUCTS, WHETHER SUCH CLAIM IS BASED ON CONTRACT, WARRANTY, NEGLIGENCE, OR STRICT LIABILITY.

In no event shall the responsibility of OMRON for any act exceed the individual price of the product on which liability is asserted.

IN NO EVENT SHALL OMRON BE RESPONSIBLE FOR WARRANTY, REPAIR, OR OTHER CLAIMS REGARDING THE PRODUCTS UNLESS OMRON'S ANALYSIS CONFIRMS THAT THE PRODUCTS WERE PROPERLY HANDLED, STORED, INSTALLED, AND MAINTAINED AND NOT SUBJECT TO CONTAMINATION, ABUSE, MISUSE, OR INAPPROPRIATE MODIFICATION OR REPAIR.

Application Considerations

SUITABILITY FOR USE

OMRON shall not be responsible for conformity with any standards, codes, or regulations that apply to the combination of products in the customer's application or use of the products.

At the customer's request, OMRON will provide applicable third party certification documents identifying ratings and limitations of use that apply to the products. This information by itself is not sufficient for a complete determination of the suitability of the products in combination with the end product, machine, system, or other application or use.

The following are some examples of applications for which particular attention must be given. This is not intended to be an exhaustive list of all possible uses of the products, nor is it intended to imply that the uses listed may be suitable for the products:

- Outdoor use, uses involving potential chemical contamination or electrical interference, or conditions or uses not described in this catalog.
- Nuclear energy control systems, combustion systems, railroad systems, aviation systems, medical equipment, amusement machines, vehicles, safety equipment, and installations subject to separate industry or government regulations.
- Systems, machines, and equipment that could present a risk to life or property.

Please know and observe all prohibitions of use applicable to the products.

NEVER USE THE PRODUCTS FOR AN APPLICATION INVOLVING SERIOUS RISK TO LIFE OR PROPERTY WITHOUT ENSURING THAT THE SYSTEM AS A WHOLE HAS BEEN DESIGNED TO ADDRESS THE RISKS, AND THAT THE OMRON PRODUCTS ARE PROPERLY RATED AND INSTALLED FOR THE INTENDED USE WITHIN THE OVERALL EQUIPMENT OR SYSTEM.

PROGRAMMABLE PRODUCTS

OMRON shall not be responsible for the user's programming of a programmable product, or any consequence thereof.

Disclaimers

CHANGE IN SPECIFICATIONS

Product specifications and accessories may be changed at any time based on improvements and other reasons.

It is our practice to change model numbers when published ratings or features are changed, or when significant construction changes are made. However, some specifications of the products may be changed without any notice. When in doubt, special model numbers may be assigned to fix or establish key specifications for your application on your request. Please consult with your OMRON representative at any time to confirm actual specifications of purchased products.

DIMENSIONS AND WEIGHTS

Dimensions and weights are nominal and are not to be used for manufacturing purposes, even when tolerances are shown.

PERFORMANCE DATA

Performance data given in this catalog is provided as a guide for the user in determining suitability and does not constitute a warranty. It may represent the result of OMRON's test conditions, and the users must correlate it to actual application requirements. Actual performance is subject to the OMRON Warranty and Limitations of Liability.

ERRORS AND OMISSIONS

The information in this document has been carefully checked and is believed to be accurate; however, no responsibility is assumed for clerical, typographical, or proofreading errors, or omissions.

2012.4

In the interest of product improvement, specifications are subject to change without notice.

OMRON Corporation
Industrial Automation Company

<http://www.ia.omron.com/>

(c)Copyright OMRON Corporation 2012 All Right Reserved.

X-ON Electronics

Largest Supplier of Electrical and Electronic Components

Click to view similar products for [Limit Switches](#) category:

Click to view products by [Omron](#) manufacturer:

Other Similar products are found below :

[5ML1-E1](#) [5ML31](#) [LZG1](#) [LZL1-6C](#) [622EN114-R](#) [622EN18-6](#) [622EN224-6B](#) [622EN230](#) [622EN237-R](#) [622EN69-3](#) [622EN85-RB](#) [MA-10019](#)
[6PA109](#) [7LS51](#) [83547001](#) [83725002](#) [83830001](#) [83840701](#) [83841001](#) [83881140](#) [8AS42](#) [8LS10](#) [8LS125-4PG](#) [8LS152-4PGN20](#) [914CE16-](#)
[3A](#) [914CE3-3L1](#) [915PA10](#) [91MCE16-P2O](#) [924CE16-Y3](#) [924CE1-S6](#) [924CE1-T25A](#) [924CE1-T3](#) [924CE1-T9A](#) [924CE2-T9](#) [924CE31-Y20-](#)
[X5](#) [924CE31-Y3L1](#) [GL-10054](#) [GLAB26J2B](#) [GLDB03C-6](#) [GLDC05C](#) [GLZ324](#) [H3141CAKAA](#) [RDI-G-L5B](#) [DD-10000](#) [DT-2R3-A7](#)
[14CE16-3N28](#) [14CE18-N15](#) [151ML3-E1](#) [E3102BAAAA](#) [BFL1-AW1-S](#)