

Slim and Compact with a Long Life





- Cover protects the built-in switch from dust and oil
- Durable plunger sealing cap ensures long life
- Connector type, screw-terminal type and pre-wired type are available
- Micro load type uses gold cladded contacts
- Designed for gang mounting
- Molded terminal types and operation-indicator types are available
- Approved standards







Agency	Standards	File No.
UL	UL508	E76675
CSA	CSA C22.2 No. 14	LR45746
TÜV Rheinland	EN60947-5-1	R9551015

Ordering Information

■ LIMIT SWITCHES

Item	Part number							
	Connector type				Screw terminal type			
	5A type		0.1A type		5A type		0.1A type	
	AC connector	DC connector	AC connector	DC connector	Without cable	With cable	Without cable	With cable
Roller plunger 	D4E-1A00N	D4E-1A10N	D4E-2A00N	D4E-2A10N	D4E-1A20N	D4E-1A21N	D4E-2A20N	D4E-2A21N
Cross-roller plunger 	D4E-1B00N	D4E-1B10N	D4E-2B00N	D4E-2B10N	D4E-1B20N	D4E-1B21N	D4E-2B20N	D4E-2B21N
Plunger 	D4E-1C00N	D4E-1C10N	D4E-2C00N	D4E-2C10N	D4E-1C20N	D4E-1C21N	D4E-2C20N	D4E-2C21N
Sealed roller plunger 	D4E-1D00N	D4E-1D10N	D4E-2D00N	D4E-2D10N	D4E-1D20N	D4E-1D21N	D4E-2D20N	D4E-2D21N

Ordering Information Table – continued from previous page

Item	Part number							
	Connector type				Screw terminal type			
	5A type		0.1A type		5A type		0.1A type	
	AC connector	DC connector	AC connector	DC connector	Without cable	With cable	Without cable	With cable
Sealed cross-roller plunger 	D4E-1E00N	D4E-1E10N	D4E-2E00N	D4E-2E10N	D4E-1E20N	D4E-1E21N	D4E-2E20N	D4E-2E21N
Sealed plunger 	D4E-1F00N	D4E-1F10N	D4E-2F00N	D4E-2F10N	D4E-1F20N	D4E-1F21N	D4E-2F20N	D4E-2F21N
Roller lever 	D4E-1G00N	D4E-1G10N	D4E-2G00N	D4E-2G10N	D4E-1G20N	D4E-1G21N	D4E-2G20N	D4E-2G21N
One-way action roller lever 	D4E-1H00N	D4E-1H10N	D4E-2H00N	D4E-2H10N	D4E-1H20N	D4E-1H21N	D4E-2H20N	D4E-2H21N

Note: For Customized Models, refer to *Molded Terminal Models* or *Operation Indicator Models* at the end of this data sheet.

MODEL NUMBER LEGEND

D4E - □ □ □ □ N
1 2 3

1. Rated Current

- 1: 5 A at 125 VAC
(1 A at 125 VAC/30 VDC for model with a connector)
- 2: 0.1 A at 125 VAC
(0.1 A at 125 VAC/30 VDC for model with a connector)

2. Actuator

- A: Roller plunger
- B: Cross-roller plunger
- C: Plunger
- D: Sealed roller plunger
- E: Sealed cross-roller plunger
- F: Sealed plunger
- G: Roller lever
- H: One-way action roller lever

3. Terminals

- 00: AC connector
- 10: DC connector
- 20: Screw terminals without a cable
- 21: Screw terminals with a cable (S-FLEX VCTF 3 m)

ACCESSORIES (ORDER SEPARATELY)

Plug

Model	Current	Type	No. of conductors	Cable length	Applicable models
XS2F-A421-350	AC	Straight	4	2 m	D4E-□□00N
XS2F-A421-450				5 m	
XS2F-D421-350	DC			2 m	D4E-□□10N
XS2F-D421-450				5 m	

Construction

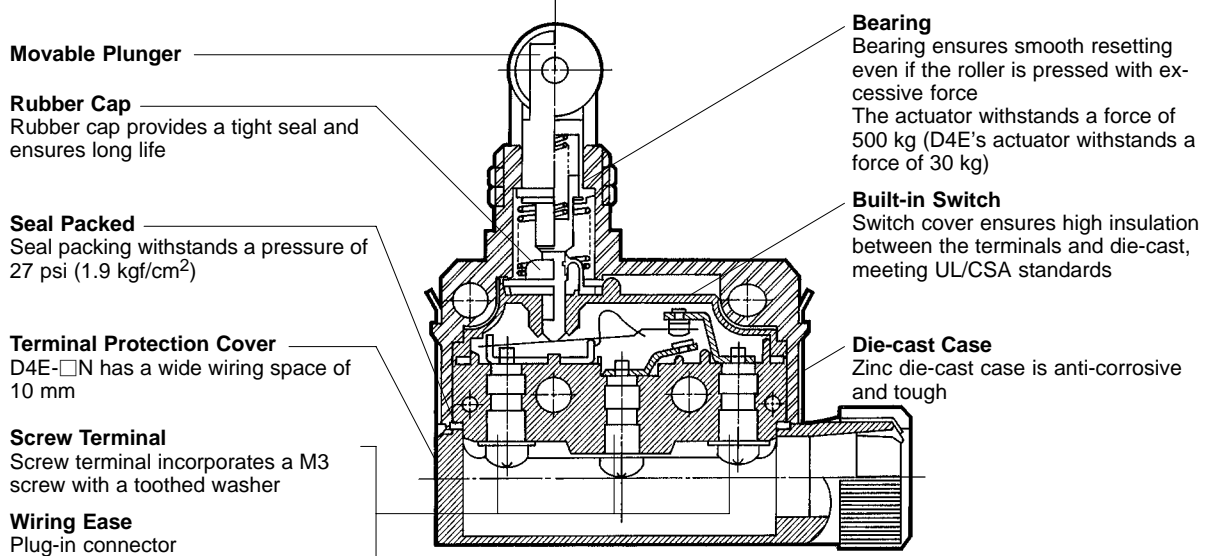

Specifications

■ RATINGS

General Ratings

Rated voltage	General-purpose								Micro load	
	Non-inductive load				Inductive load				Non-inductive load	
	Resistive load		Lamp load		Inductive load		Motor load		Resistive load	
	NC	NO	NC	NO	NC	NO	NC	NO	NC	NO
125 VAC	5 (1) A		1.5 (1) A		3 (1) A		2 (1) A	1 (1) A	0.1 A	
250 VAC	5 (1) A		1.5 (1) A		3 (1) A		1 A	0.5 A	---	
8 VDC	5 (1) A		---		1.5 (1) A		---		0.1 A	
14 VDC	5 (1) A		---		1.5 (1) A		---		0.1 A	
30 VDC	5 (1) A		---		1.5 (1) A		---		0.1 A	
125 VDC	0.5 A		---		0.05 A		---		---	
250 VDC	0.25 A		---		0.03 A		---		---	

- Note: 1. The above current ratings are for steady-state current and the value in parentheses is for models with a connector.
 2. Inductive loads have a power factor of 0.4 min. (AC) and a time constant of 7 ms max. (DC).
 3. Lamp loads have an inrush current of 10 times the steady-state current.
 4. Motor loads have an inrush current of 6 times the steady-state current.

EN60947-5-1 Ratings

D4E- 1 G 23 L N - ABC

I II III IV V

I	II	III	IV	Category and rating	I _{the}	Indicator
1	<input type="checkbox"/>	00		AC-14 0.5 A/125 VAC	5 A	None
1	<input type="checkbox"/>	10		DC-12 0.5 A/30 VDC	5 A	None
1	<input type="checkbox"/>	20, 21, 22		AC-15 2 A/250 VAC DC-12 2 A/48 VDC	5 A	None
1	<input type="checkbox"/>	23, 24	L	AC-15 2 A/250 VAC	5 A	Neon lamp
1	<input type="checkbox"/>	23, 24	L1	DC-12 2 A/12 VDC	5 A	LED
1	<input type="checkbox"/>	23, 24	L2	DC-12 2 A/24 VDC	5 A	LED
1	<input type="checkbox"/>	23, 24	L3	DC-12 2 A/48 VDC	5 A	LED
2	<input type="checkbox"/>	00		AC-14 0.1 A/125 VAC	0.5 A	None
2	<input type="checkbox"/>	10		DC-12 0.1 A/30 VDC	0.5 A	None
2	<input type="checkbox"/>	20, 21, 22		AC-14 0.1 A/125 VAC DC-12 0.1 A/48 VDC	0.5 A	None
2	<input type="checkbox"/>	23, 24	L	AC-14 0.1 A/125 VAC	0.5 A	Neon lamp
2	<input type="checkbox"/>	23, 24	L1	DC-12 0.1 A/12 VDC	0.5 A	LED
2	<input type="checkbox"/>	23, 24	L2	DC-12 0.1 A/24 VDC	0.5 A	LED
2	<input type="checkbox"/>	23, 24	L3	DC-12 0.1 A/48 VDC	0.5 A	LED

Note: : Actuator variation of item II

UL Rating

NEMA A300

■ CHARACTERISTICS

Operating speed		0.1 mm to 0.5 m/sec (0.0039 to 19.6 in/s)
Operating frequency	Mechanical	120 operations/min
	Electrical	30 operations/min
Insulation resistance		100 MΩ min. (at 500 VDC)
Contact resistance		15 mΩ max. (initial value)
Dielectric strength		1,000 VAC, 50/60 Hz for 1 min between terminals of same polarity 1,500 VAC, 50/60 Hz for 1 min between current-carrying metal parts and ground, and between each terminal and non-current-carrying metal part
Inrush current		NC/NO: 10 A max.
Rated insulation voltage (U _i)		250 VAC (EN60947-5-1)
Rated impulse withstand voltage (U _{imp})		6 kV (EN60947-5-1)
Operating environment pollution degree		3 (EN60947-5-1)
Short-circuit protective device		Fuse (type gG or gl, IEC269 approved)
Conventional enclosed thermal current		5 A (0.5 A for micro load type) (EN60947-5-1)
Protection against electric shock		Class II (double insulation)
Vibration resistance		Malfunction: 10 to 55 Hz, 1.5-mm double amplitude
Shock resistance	Destruction	1,000 m/s ² min. (approx. 100G min.)
	Malfunction	300 m/s ² min. (approx. 30G min.)
Life expectancy	Mechanical	10,000,000 operations min.
	Electrical	500,000 operations min. (5 A at 250 VAC, resistive load) 5,000,000 operations min. (10 mA at 24 VDC, resistive load) for micro load
Ambient temperature	Operating	-10°C to 80°C (14°F to 176°F) with no icing
Ambient humidity	Operating	95% max.
Enclosure rating		IEC IP67 UL/CSA: 3, 4, 13
Weight		Approx. 83 g (2.93 oz) except for lead wires

■ OPERATING CHARACTERISTICS

Model	D4E-1A□□N D4E-2A□□N	D4E-1B□□N D4E-2B□□N	D4E-1C□□N D4E-2C□□N	D4E-1D□□N D4E-2D□□N
OF max.	11.76 N (1,200 gf) 2.64 lbf	11.76 N (1,200 gf) 2.64 lbf	11.76 N (1,200 gf) 2.64 lbf	11.76 N (1,200 gf) 2.64 lbf
RF min.	4.9 N (500 gf) 1.1 lbf	4.9 N (500 gf) 1.1 lbf	4.9 N (500 gf) 1.1 lbf	4.9 N (500 gf) 1.1 lbf
PT max.	1.5 mm	1.5 mm	1.5 mm	1.5 mm
OT min.	3 mm	3 mm	3 mm	3 mm
MD	0.1 mm	0.1 mm	0.1 mm	0.1 mm
OP	31.4±0.8 mm	31.4±0.8 mm	25.4±0.8 mm	41.3±0.8 mm

Model	D4E-1E□□N D4E-2E□□N	D4E-1F□□N D4E-2F□□N	D4E-1G□□N D4E-2G□□N	D4E-1H□□N D4E-2H□□N
OF max.	11.76 N (1,200 gf) 2.64 lbf	11.76 N (1,200 gf) 0.88 lbf	3.92 N (400 gf) 0.88 lbf	3.92 N (400 gf) 0.88 lbf
RF min.	4.9 N (500 gf) 1.1 lbf	4.9 N (500 gf) 1.1 lbf	0.78 N (80 gf) 0.18 lbf	0.78 N (80 gf) 0.18 lbf
PT max.	1.5 mm	1.5 mm	2 mm	2 mm
OT min.	3 mm	3 mm	4 mm	4 mm
MD	0.1 mm	0.1 mm	0.3 mm	0.3 mm
OP	41.3±0.8 mm	30±0.8 mm	23.1±0.8 mm	31.4±0.8 mm

Engineering Data

■ ELECTRICAL LIFE EXPECTANCY ($\cos\phi = 1$)

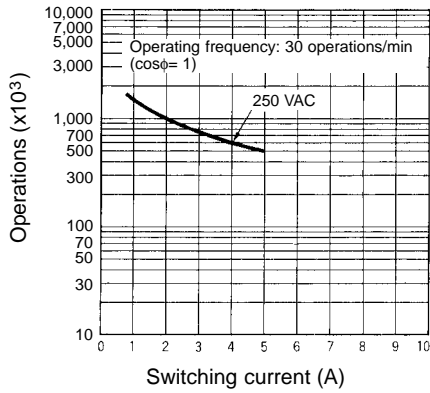

Operation

■ CONTACT FORM

Screw-Terminal Type

Plunger

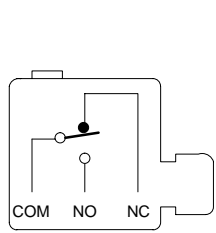

Lever

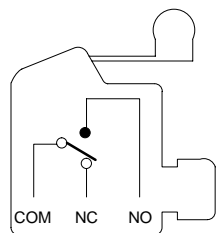

Connector Type

AC

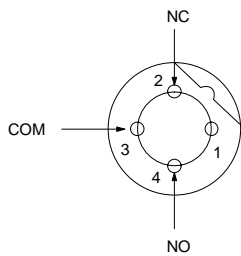

DC

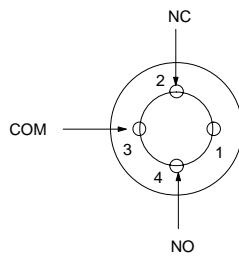

Dimensions

Unit: mm (inch)

■ LIMIT SWITCHES

D4E-1A00N
D4E-1A10N
D4E-2A00N
D4E-2A10N

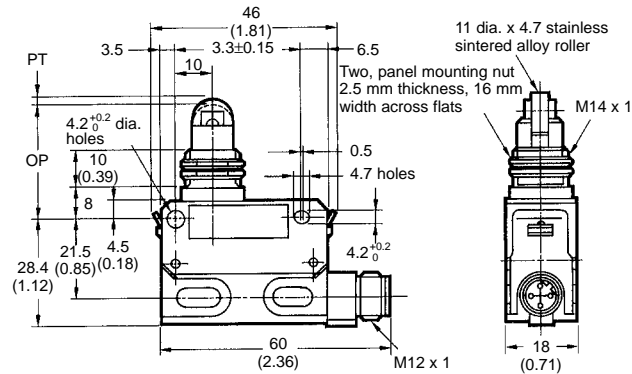
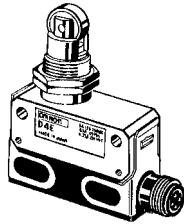

D4E-1A20N
D4E-2A20N

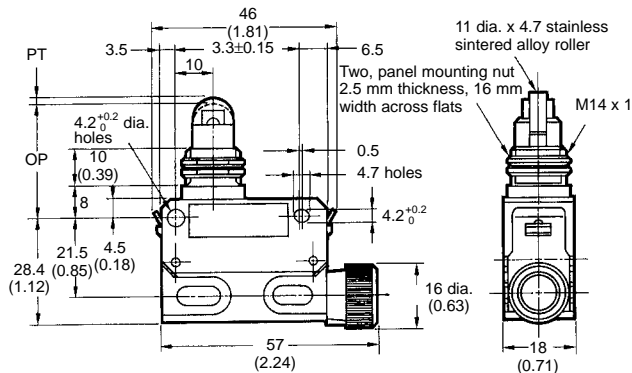
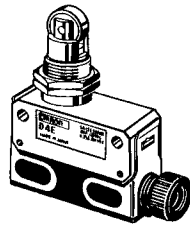

D4E-1B00N
D4E-1B10N
D4E-2B00N
D4E-2B10N

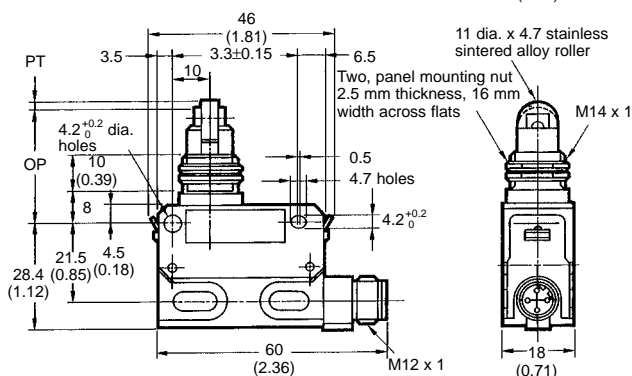
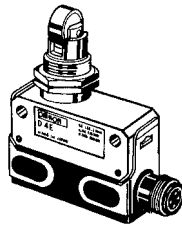

D4E-1B20N
D4E-2B20N

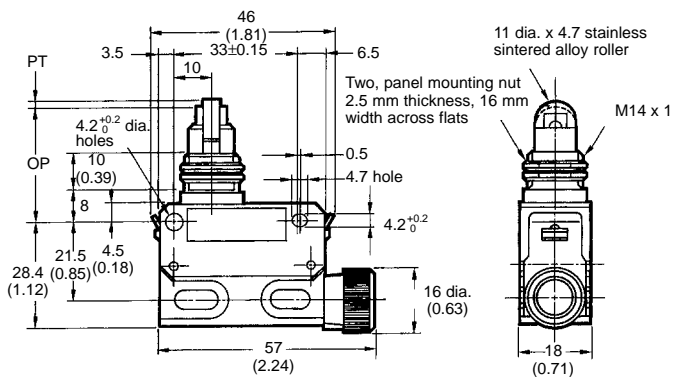
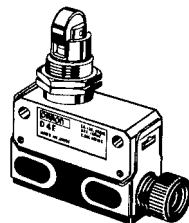

- Note: 1. Unless otherwise specified, a tolerance of ± 0.4 mm applies to all dimensions.
2. A 3-m lead wire cable equivalent to the 3-conductor VCTF S-FLEX cable (0.75 mm², 7 mm in dia.) is provided.
3. A 5.8-mm to 7.6-mm cable can be applied to the seal rubber for the lead wire outlet.

Unit: mm (inch)

D4E-1C00N
D4E-1C10N
D4E-2C00N
D4E-2C10N

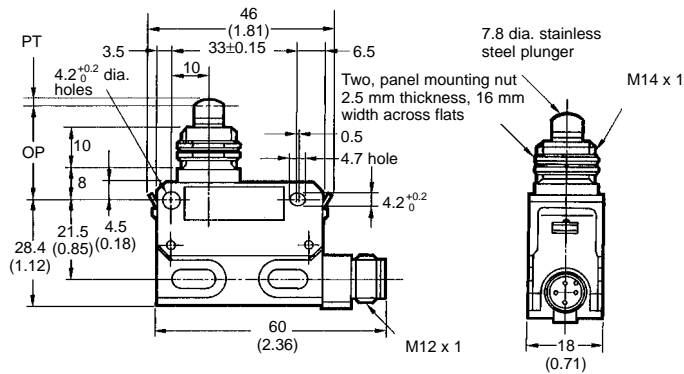
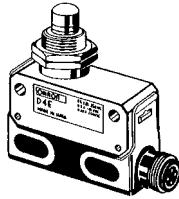

D4E-1C20N
D4E-2C20N

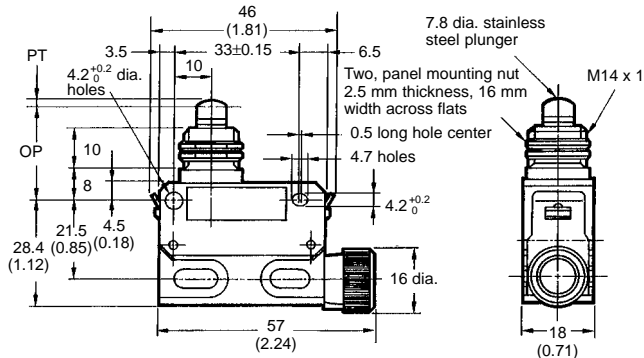
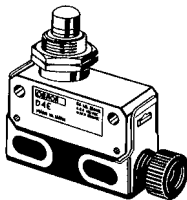

D4E-1D00N
D4E-1D10N
D4E-2D00N
D4E-2D10N

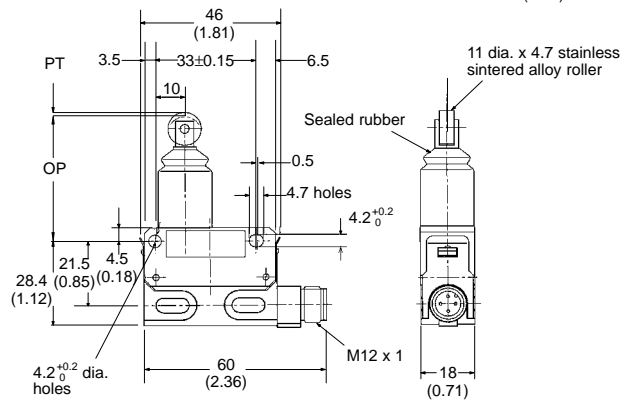
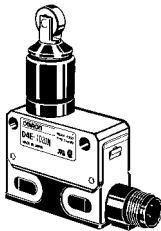

D4E-1D20N
D4E-2D20N

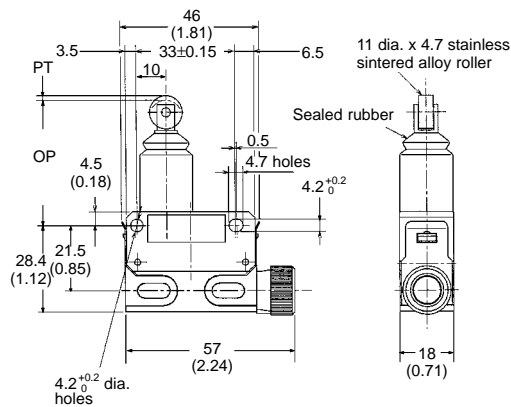
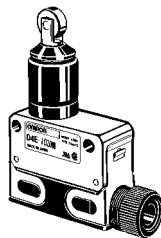

- Note: 1. Unless otherwise specified, a tolerance of ±0.4 mm applies to all dimensions.
2. A 3-m lead wire cable equivalent to the 3-conductor VCTF S-FLEX cable (0.75 mm², 7 mm in dia.) is provided.
3. A 5.8-mm to 7.6-mm cable can be applied to the seal rubber for the lead wire outlet.

D4E-1E00N
D4E-1E10N
D4E-2E00N
D4E-2E10N

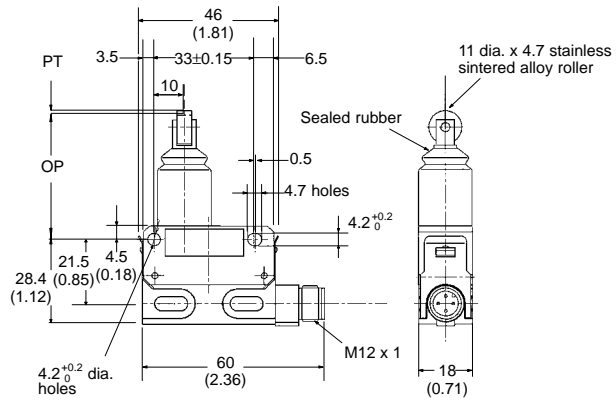
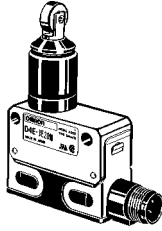

D4E-1E20N
D4E-2E20N

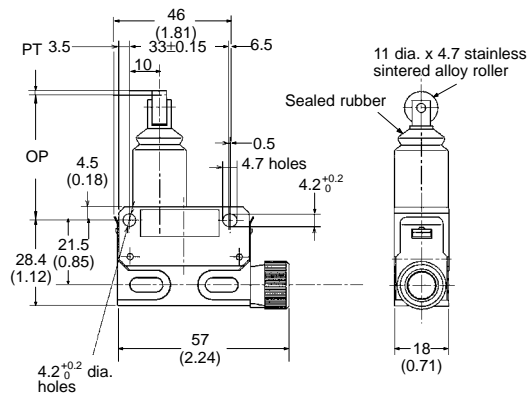
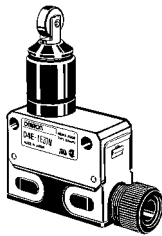

D4E-1F00N
D4E-1F10N
D4E-2F00N
D4E-2F10N

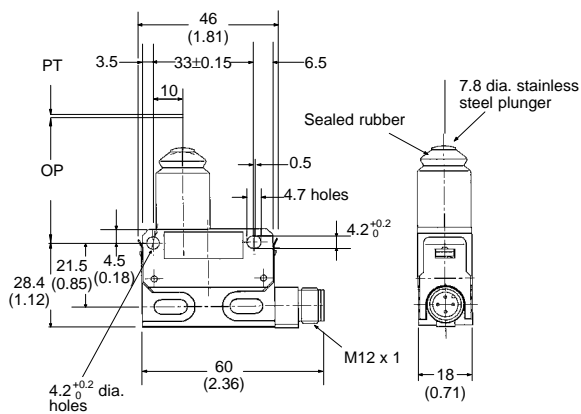
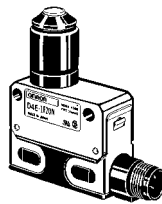

D4E-1F20N
D4E-2F20N

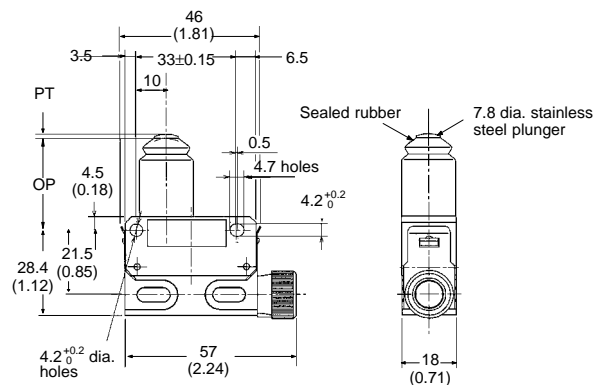
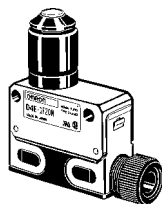

- Note: 1. Unless otherwise specified, a tolerance of ± 0.4 mm applies to all dimensions.
2. A 3-m lead wire cable equivalent to the 3-conductor VCTF S-FLEX cable (0.75 mm², 7 mm in dia.) is provided.
3. A 5.8-mm to 7.6-mm cable can be applied to the seal rubber for the lead wire outlet.

Unit: mm (inch)

D4E-1G00N
D4E-1G10N
D4E-2G00N
D4E-2G10N

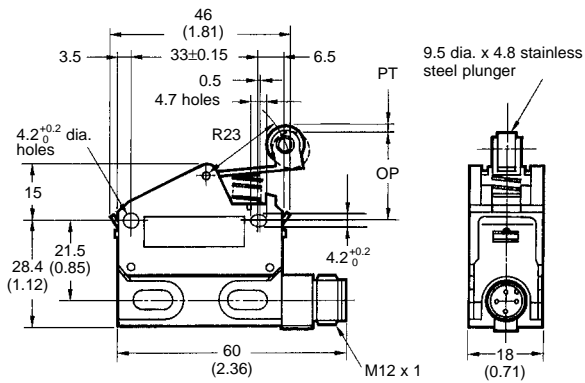
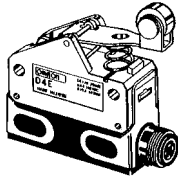

D4E-1G20N
D4E-2G20N

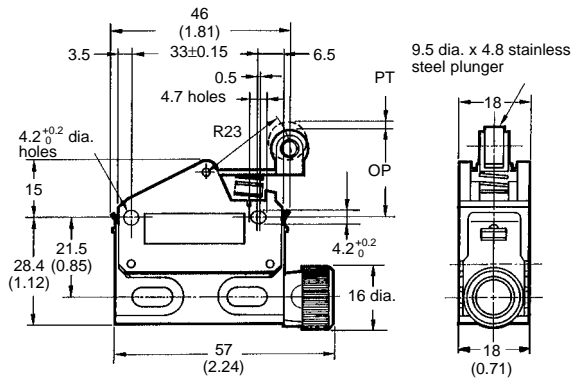
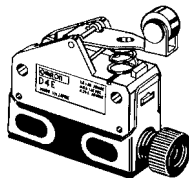

D4E-1H00N
D4E-1H10N
D4E-2H00N
D4E-2H10N

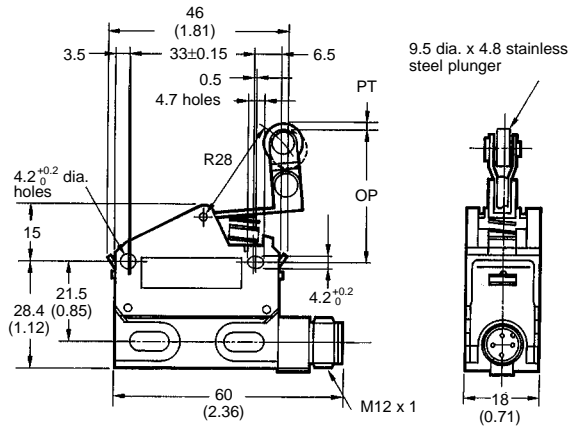
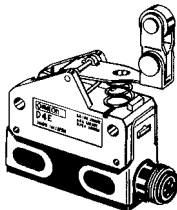

D4E-1H20N
D4E-2H20N

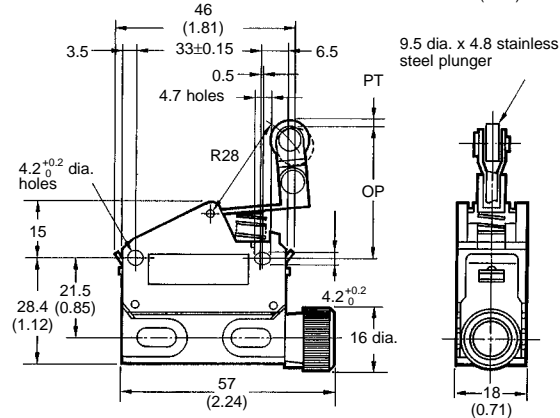
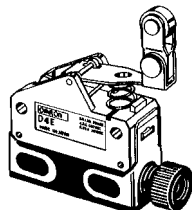

- Note: 1. Unless otherwise specified, a tolerance of ± 0.4 mm applies to all dimensions.
2. A 3-m lead wire cable equivalent to the 3-conductor VCTF S-FLEX cable (0.75 mm², 7 mm in dia.) is provided.
3. A 5.8-mm to 7.6-mm cable can be applied to the seal rubber for the lead wire outlet.

Customized Models

Molded Terminal Models

■ ORDERING INFORMATION

The molded-terminal model is available with right-hand, left-hand and underside leads. Molded terminal is recommended for use wherever the switch is exposed to dust, oil or moisture.

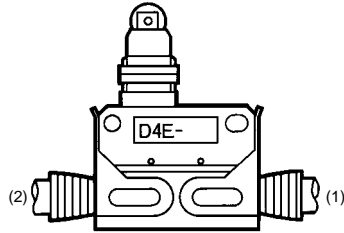

Example:

Standard type: D4E-1A20N

Location of lead output: Right-hand

Part number: D4E-1A23N

Suffix by Location of Lead Outlet

Location of lead output	Part number
Right-hand: side (1) in above drawing	D4E-□□23N
Left-hand: side (2) in above drawing	D4E-□□24N

Lead Supplies

Leads	Nominal cross-sectional area	Finished outside diameter	Terminal connections	Standard length
V.C.T.F. S-FLEX (vinyl cabtyre coat)	0.75 mm ²	3 conductors 7 mm (0.28 in) dia.	Black: COM White: NO Red: NC	3 m (118.11 in)

Operation Indicator Equipped Model

The molded terminal model may be equipped with an operation indicator (neon lamp or LED) upon request.

The operation indicator is designed to illuminate when the switch is not operating. (Because of the molded terminal, no change to the switch wiring can be made.)

■ AC OPERATION

A neon lamp indicator is provided.
The operating voltage is 90 to 250 VAC.

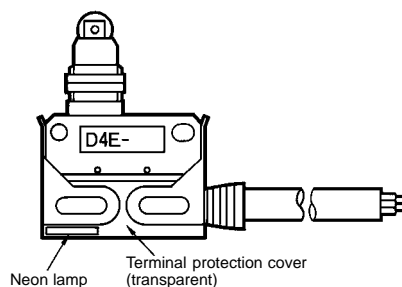

Example:

Basic type: D4E-1A23N

When placing your order for the molded terminal model with a neon lamp operation indicator, specify the model number as D4E-1A23LN.

Internal Circuit

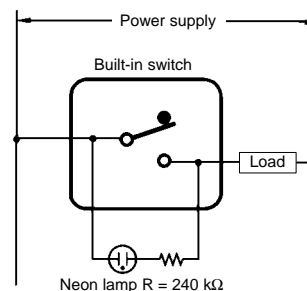

DC OPERATION

LED indicator is provided.
Due to a rectifier stack, this type can also be operated on AC.

Voltage ratings of LED indicators are as shown in the table below.

Internal Circuit

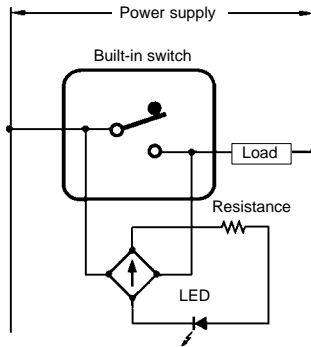

Type	Voltage rating	Lamp current	Internal resistance
L1	12 V	Approx. 2.4 mA	4.3 kΩ
L2	24 V	Approx. 1.2 mA	18 kΩ
L3	48 V	Approx. 2.1 mA	22 kΩ

Example:

When ordering a D4E DC Model, add the following suffix to the model number.

Basic Model: The model number of the D4E-1A23N with a built-in 12-V LED indicator is D4E-1A23L1N.

Precautions

MOUNTING

For side mounting, use M4 screws and washers. The appropriate clamping torque is in the range of 14 to 16 kgf • cm (1.37 to 1.57 N • m) 1.01 to 1.16 ft • lbf.

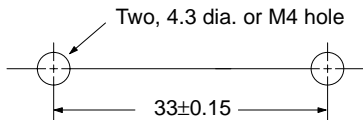

When the panel mounted model is used for side mounting, remove the hexagon nut from the actuator.

When a panel mounted model is mounted, the clamping torque of the hexagon nut should be 7.85 N • m (80 kgf • cm) 5.79 ft • lbf max.

Mounting Holes

14.5±0.2 dia.
(0.57±0.008 in dia.)

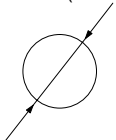

When the one-touch connector is to be mounted onto the switch body, push up the fitting lightly and the switch body can then be inserted into the clamp.

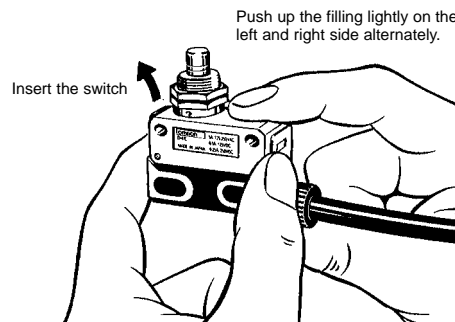

OPERATING

The operating methods, cam and dog's shapes, operating frequency, and overtravel (OT) have a big influence on the life and accuracy of the switch. The shape of the cam should be as smooth as possible.

A marginal overtravel (OT) value should be set. The ideal value is the rated OT value x 0.7.

The actuator should not be remodeled to change the operating position.

■ WIRING

In the case of screw terminal wiring, securely connect the lead to terminals with a tightening torque of 0.6 to 0.8 N • m (6 to 8 kgf • cm) 0.44 to 0.59 ft • lbf. M3.5-size round solderless terminals with an insulation tube is recommended. The conductor size should be 0.75 mm² and cable diameter should be 7 mm.

Refer to the following when wiring.

Round Solderless Conductor

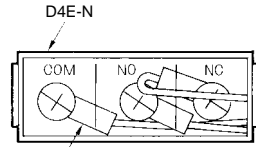

Round solderless terminal

Do not solder the screw terminals.

■ ENVIRONMENT

Do not use a D4E-□N Small Sealed Switch in areas with excessive moisture or where hot water (with a temperature of 60°C or over) may be scattered over the switch.

Consult your OMRON representative before attempting to use a D4E-□N Small Sealed Switch outdoors or in areas where lubricating oil may deteriorate the switch housing.

NOTE: DIMENSIONS SHOWN ARE IN MILLIMETERS. To convert millimeters to inches divide by 25.4.

OMRON[®]
OMRON ELECTRONICS, INC.
One East Commerce Drive
Schaumburg, IL 60173
1-800-55-OMRON

OMRON CANADA, INC.
885 Milner Avenue
Scarborough, Ontario M1B 5V8
416-286-6465

X-ON Electronics

Largest Supplier of Electrical and Electronic Components

Click to view similar products for [Limit Switches](#) category:

Click to view products by [Omron](#) manufacturer:

Other Similar products are found below :

[5ML1-E1](#) [5ML31](#) [LZG1](#) [LZL1-6C](#) [622EN114-R](#) [622EN18-6](#) [622EN224-6B](#) [622EN230](#) [622EN237-R](#) [622EN69-3](#) [622EN85-RB](#) [MA-10019](#)
[6PA109](#) [7LS51](#) [83547001](#) [83725002](#) [83830001](#) [83840701](#) [83841001](#) [83881140](#) [8AS42](#) [8LS10](#) [8LS125-4PG](#) [8LS152-4PGN20](#) [914CE16-](#)
[3A](#) [914CE3-3L1](#) [915PA10](#) [91MCE16-P2O](#) [924CE16-Y3](#) [924CE1-S6](#) [924CE1-T25A](#) [924CE1-T3](#) [924CE1-T9A](#) [924CE2-T9](#) [924CE31-Y20-](#)
[X5](#) [924CE31-Y3L1](#) [GL-10054](#) [GLAB26J2B](#) [GLDB03C-6](#) [GLDC05C](#) [GLZ324](#) [H3141CAKAA](#) [RDI-G-L5B](#) [DD-10000](#) [DT-2R3-A7](#)
[14CE16-3N28](#) [14CE18-N15](#) [151ML3-E1](#) [E3102BAAAA](#) [BFL1-AW1-S](#)