

## Adjustable Flat Capacitive Prox

## E2J

Thin Sensor with Separate Amplifier  
 Ideal for Robotic Grippers, Wafers,  
 LCD, and PDP Detection  
 Applications

- Adjustable sensitivity on separate amplifier
- Flat sensing head is only 5.5 mm thick
- Robotic cable takes continuous flexing
- Dual LED indicator for power and output



## Ordering Information

### ■ SENSORS

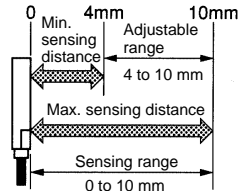
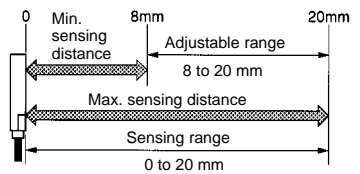
Type	Sensing distance	Part number
Flat Unshielded 		<b>E2J-W10MA</b>
		<b>E2J-W20MA</b>

### ■ AMPLIFIER UNIT

Type	Output configuration	Part number
DC 3-wire	NPN open collector, switch selectable NO or NC operation	<b>E2J-JC4A</b>

## ■ ACCESSORIES (SOLD SEPARATELY)

Description		Part number	
Extension robotic cables	M8-screw-mounting, vibration-proof, 4 conductors	1 m (3.3 ft) length	<b>XS3W-M421-401-R</b>
		2 m (6.6 ft) length	<b>XS3W-M421-402-R</b>
Connector dust covers	Red PVC, does not seal to IP67	For amplifier	<b>XS3Z-13</b>
		For sensing head	<b>XS3Z-15</b>

## Specifications

### ■ RATINGS/CHARACTERISTICS

#### Sensors

Part number		E2J-W10MA	E2J-W20MA
Sensing distance adjustable range		4 to 10 mm (0.16 to 0.39 in)	8 to 20 mm (0.32 to 0.79 in)
Sensing range		0 to 10 mm (0 to 0.39 in)	0 to 20 mm (0 to 0.79 in)
Standard sensing target		50 x 50 mm grounded metal (t = 1 mm)	
Sensing target		Metallic and non-metallic objects	
Differential travel		15% max. of sensing distance	
Response frequency		70 kHz max.	
Ambient temperature	Operating	-10°C to 55°C (14°F to 131°F)	
Ambient humidity	Operating	35% to 95%	
Enclosure rating		IEC IP66	
Vibration resistance	Malfunction	10 to 500 Hz, 2.0-mm double amplitude or 150 m/s <sup>2</sup> (approx. 15G) for 2 hrs each in X, Y, and Z directions	
Shock resistance	Malfunction	500 m/s <sup>2</sup> (approx. 50G) for 3 times each in X, Y, and Z directions	
Weight		Approx. 30 g (1.05 oz)	Approx. 40 g (1.4 oz)
Case material		ABS resin	

#### Amplifier Unit

Part number		E2J-JC4A
Supply voltage		24 VDC±10%, ripple (p-p): 10% max.
Current consumption		30 mA max.
Control output		100 mA max., NPN open collector
Output residual voltage		1 V max.
Circuit protection		Reverse connection, load short-circuit, and surge absorption
Ambient temperature	Operating	-10°C to 55°C (14°F to 131°F)
Ambient humidity	Operating	35% to 85%
Temperature influence (Sensor Head and Amplifier Unit)		±25% max. of sensing distance at 23°C (73.4 °F) in temperature range of 0°C to 40°C (32°F to 104°F)
Voltage influence		±1% max. of sensing distance in rated voltage range of ±20%
Insulation resistance		50 MΩ (at 500 VDC) between current carry parts and case
Dielectric strength		1,000 VAC (50/60 Hz) for 1 min between current carry parts and case
Vibration resistance	Malfunction	10 to 150 Hz, 1.5-mm double amplitude or 150 m/s <sup>2</sup> (approx. 15G) for 2 hrs each in X, Y, and Z directions
Shock resistance	Malfunction	300 m/s <sup>2</sup> (approx. 30G) for 3 times each in X, Y, and Z directions
Enclosure rating		IEC IP50
Weight		Approx. 60 g (21 oz)
Case material		ABS

# Operation

## ■ OUTPUT CIRCUIT

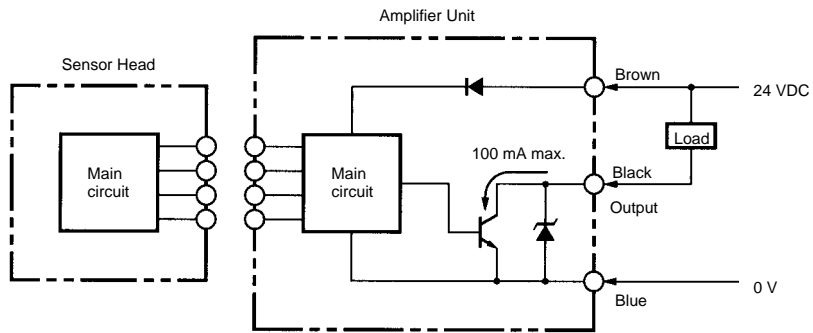

## ■ OPERATING CHARTS

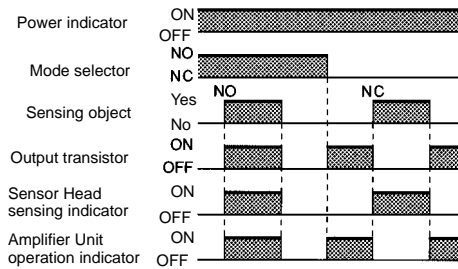

NO [Hatched box] The output transistor is ON when the sensing object is detected.  
 NC [Empty box] The output transistor is ON when the sensing object is not detected.

# Engineering Data

## ■ SENSING DISTANCE VS. SENSING OBJECT (IRON)

E2J-W10MA

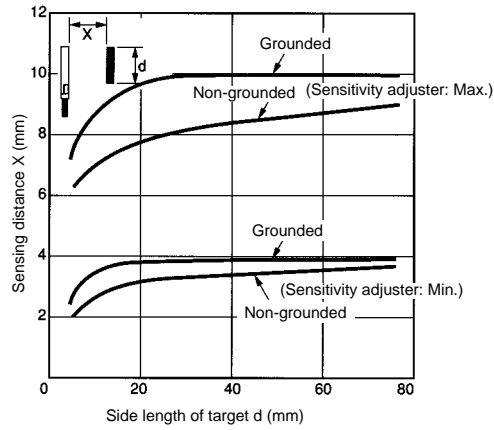

E2J-W20MA

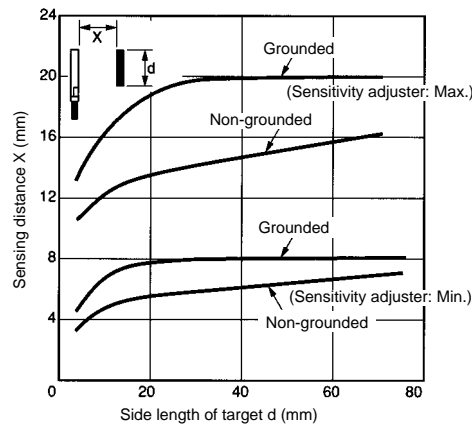

## ■ INFLUENCE OF AMBIENT TEMPERATURE

E2J-W10MA

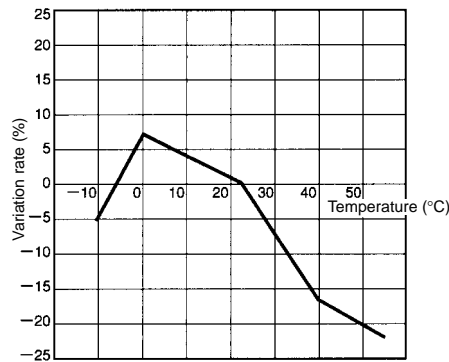

E2J-W20MA

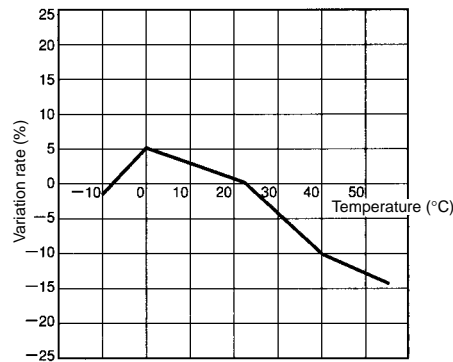

■ SENSING DISTANCE OF SENSING OBJECTS

E2J-W10MA

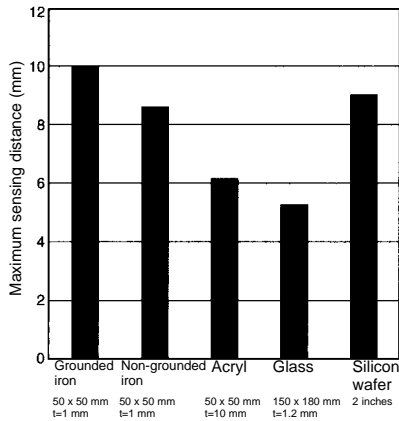

E2J-W20MA

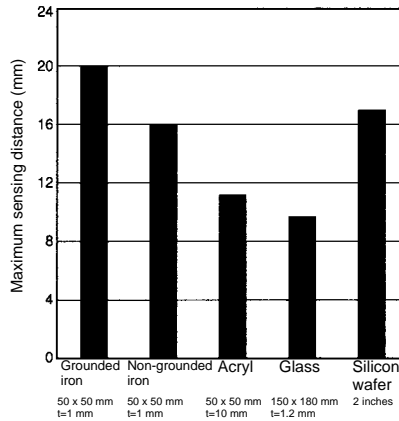

■ SENSING RANGES

E2J-W10MA

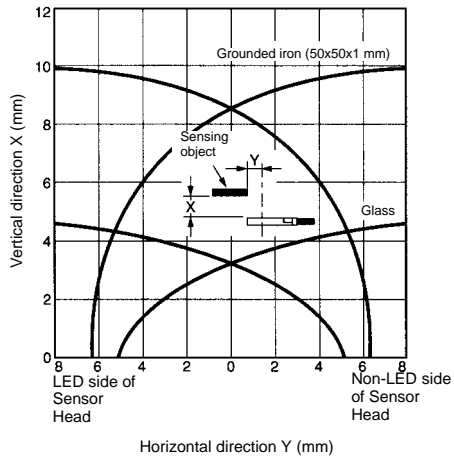

E2J-W20MA

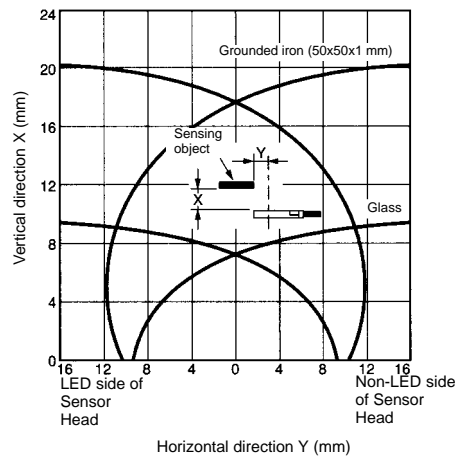

Dimensions

Unit: mm (inch)

■ SENSORS

E2J-W10MA

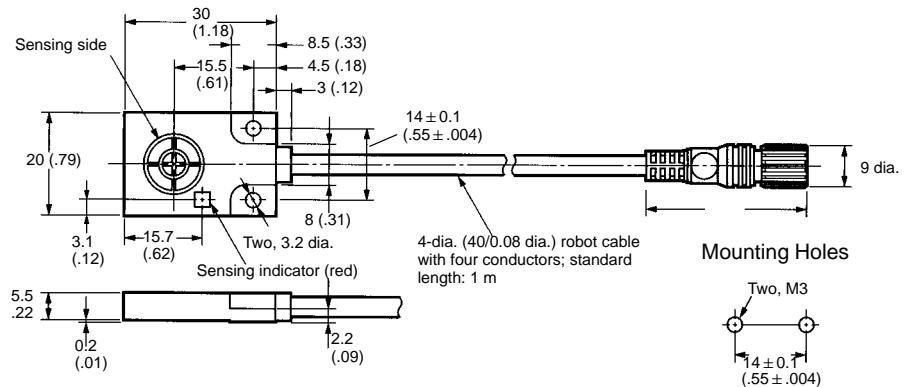
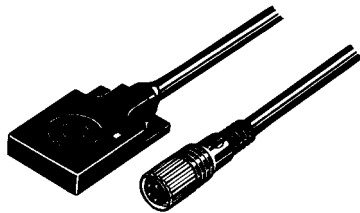

Unit: mm (inch)

**E2J-W20MA**

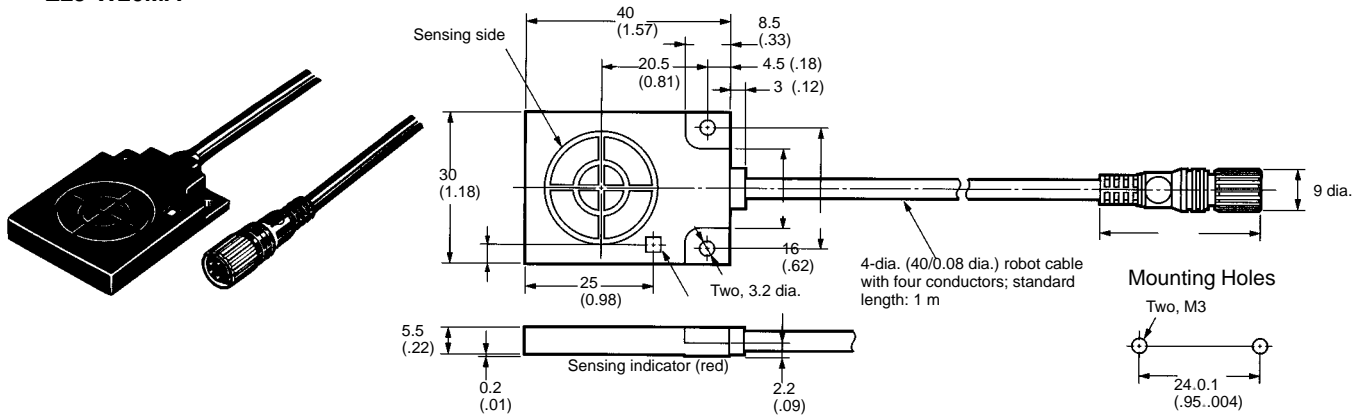

■ **AMPLIFIER UNIT**

**E2J-JC4A**

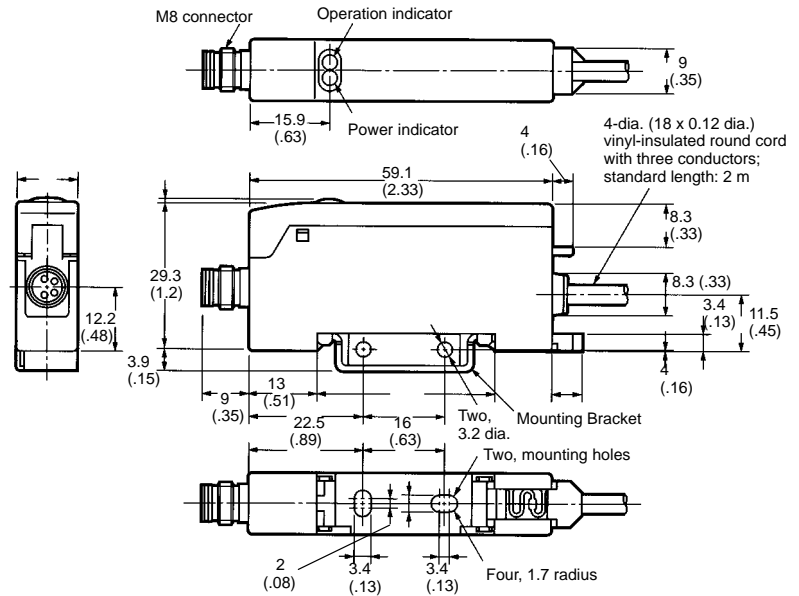
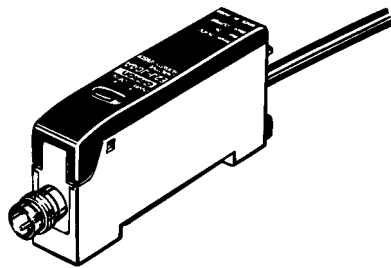

■ **CONNECTOR DUST COVERS**

**XS3Z-13**  
**XS3Z-15**

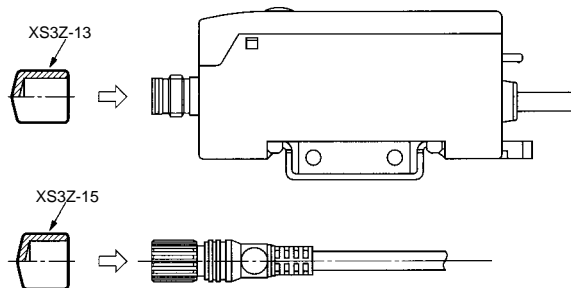

Note: Although the XS3Z Dust Covers protect the E2J from dust, they do not satisfy IP67. When attaching the Dust Cover, be sure to fully insert the connector into the Dust Cover.

## ■ EXTENSION ROBOTIC CABLES

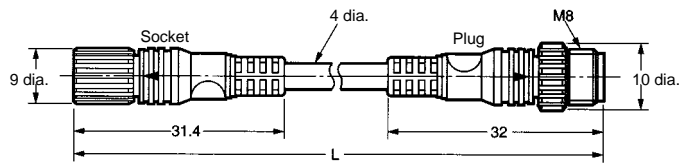

Part number	L
XS3W-M421-401-R	1 m
XS3W-M421-402-R	2 m

## Nomenclature

### ■ AMPLIFIER UNIT

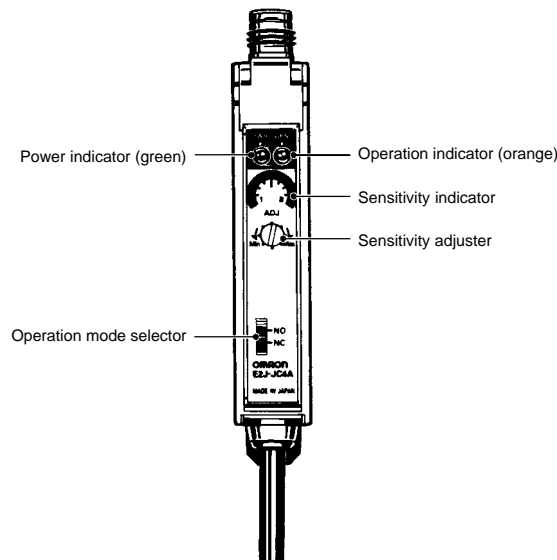

## Installation

### ■ ADJUSTMENT PROCEDURE

Step	Sensing	Sensitivity adjuster	Adjustment
1		---	Obtain the sensing distance X from the set distance S divided by 0.75. (See note). Determine S so that X will be less than the maximum sensing distance.
2			Locate the Sensor so that the distance between the Sensor and sensing object is X. Turn the sensitivity adjuster clockwise until the red sensing indicator of the Sensor Head is lit.
3		---	Return the Sensor to the previous position so that the distance between the Sensor and sensing object is S.

- Note: 1. If the ambient temperature is beyond 0°C to 40°C, divide by 0.7 to obtain sensing distance.  
 2. After completing sensitivity adjustment, mount the provided cover on the Amplifier Unit to prevent misoperation.  
 3. The maximum sensing distance will drop depending on the dimensions and material of the sensing object. Refer to *Engineering Data*.

# Precautions

## SAFETY PRECAUTIONS

- Do not use the sensor in an environment where it will be exposed to inflammable or explosive gases.
- Do not attempt to disassemble, repair, or modify the Sensor.
- Be careful not to connect the power source with the polarities in reverse.
- Do not short-circuit the loads.
- Do not use the Sensor at voltages exceeding the rated voltage.

## HANDLING

- Do not use the Sensor outdoors.
- Do not wire the Sensor alongside a high-tension or power line.
- Do not use portable telephones or transceivers near the Sensor. Be sure to ground the Mounting Brackets.
- Do not use the Sensor in an environment where it will be exposed to chemicals, particularly chemical solutions or oxidizing acids.

## TIGHTENING TORQUE

Be sure that the tightening torque does not exceed the following value.

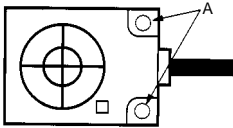

Location	Torque
A	0.54N • m {5.5 kgf • cm} max.

## EFFECTS OF SURROUNDING METAL

Before mounting the sensor, be sure that the sensor will be separated from surrounding objects as shown in the following illustration.

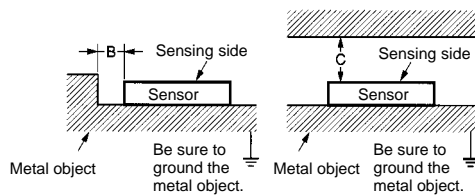

Dimension	E2J-W10MA	E2J-W20MA
B	10 mm (0.39 in)	20 mm (0.79 in)
C	20 mm (0.79 in)	40 mm (1.57 in)

## EFFECTS OF STATIC ELECTRICITY

Be sure to discharge static electricity before detecting objects that are greatly affected by static electricity.

## MUTUAL INTERFERENCE

When mounting more than two sensors face to face or side by side, ensure that the minimum distances given in the following table are maintained.

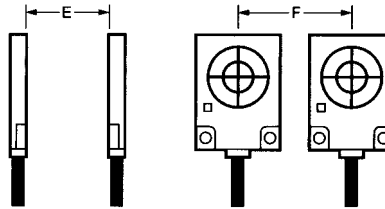

Distance	E2J-W10MA	E2J-W20MA
E	20 mm (0.79 in)	70 mm (2.76 in)
F	30 mm (1.18 in)	50 mm (1.97 in)

## CABLING

- Be sure that the bending radius of the cable is more than 5 mm.
- Use the XS3W-M421-40□-R with connectors (M8-screw-mounting type) as the extension cable. The maximum cable length is 3 m (extension section: 2 m).

## TRACK MOUNTING THE AMPLIFIER UNIT

### Mounting

- Mount the front part of the amplifier to the mounting bracket provided with the amplifier or a DIN track.
- Press the rear part of the amplifier onto the mounting bracket or DIN track.

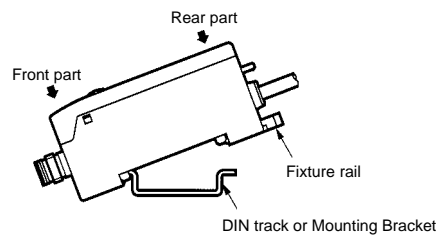

### Removal

Pull the fixture rail with a flat-blade screwdriver for easy removal.



**NOTE: DIMENSIONS SHOWN ARE IN MILLIMETERS. To convert millimeters to inches divide by 25.4.**

---

**OMRON**<sup>®</sup>  
**OMRON ELECTRONICS, INC.**  
One East Commerce Drive  
Schaumburg, IL 60173  
**1-800-55-OMRON**

**OMRON CANADA, INC.**  
885 Milner Avenue  
Scarborough, Ontario M1B 5V8  
**416-286-6465**

## X-ON Electronics

Largest Supplier of Electrical and Electronic Components

*Click to view similar products for [Proximity Sensors](#) category:*

*Click to view products by [Omron](#) manufacturer:*

Other Similar products are found below :

[01.001.5653.1](#) [70.340.1028.0](#) [70.360.2428.0](#) [70.364.4828.0](#) [70.810.1053.0](#) [72.360.1628.0](#) [73.363.6428.0](#) [8027AL20NL2CPXX](#) [FYCC8E1-2](#)  
[9221350022](#) [922AA2W-A9P-L](#) [PLS2](#) [GL-12F-C2.5X10\(LOT3\)](#) [972AB2XM-A3N-L](#) [972AB3XM-A3P-L](#) [PS3251](#) [980659-1](#) [QT-12](#) [E2E2-](#)  
[X5M41-M4](#) [E2E-X14MD1-G](#) [E2E-X2D1-G](#) [E2EX2ME2N](#) [E2EX3D1SM1N](#) [E2E-X4MD1-G](#) [E2E-X5E1-5M-N](#) [E2E-X5Y2-N](#) [E2E-X7D1-](#)  
[M1J-T-0.3M-N](#) [E2FMX1R5D12M](#) [E2K-F10MC1](#) [5M](#) [EH-302](#) [EI3010TBOP](#) [EI5515NPAP](#) [MS605AU](#) [EP175-32000](#) [IFRM04N35B1/L](#)  
[IFRM04P1513/S35L](#) [IFRM06P1703/S35L](#) [IFRM08P1501/S35L](#) [IFRM12N17G3/L](#) [IFRM12P17G3/L](#) [IFRM12P3502/L](#) [IFRM12P37G1/S14L](#)  
[ILFK12E9189/I02](#) [ILFK12E9193/I02](#) [IMM2582C](#) [OISN-013](#) [25.161.3253.0](#) [25.332.0653.1](#) [25.352.0653.0](#) [25.352.0753.0](#)