

Ordering Information

Sensors

Series	Connection method	Model	
		NPN output	PNP output
E2SS-M	Pre-wired	E2SS-MC1 2M	E2SS-MB1 2M
	Pre-wired connector	E2SS-MC1-M1J 0.3M	E2SS-MB1-M1J 0.3M
E2SS-W	Connector	E2SS-WC1-P1	E2SS-WB1-P1

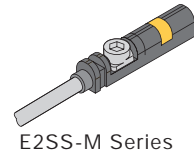

E2SS-M Series

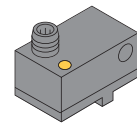

E2SS-W Series

Mounting Brackets

Series	Applicable cylinders	Cylinder diameter or groove width	Model
E2SS-M	Round	8 to 25 mm dia.	E2SS-MR1
		25 to 63 mm dia.	E2SS-MR2
	Tie-rod	32 to 40 mm dia.	E2SS-MT1
		50 to 63 mm dia.	E2SS-MT2
		80 to 100 mm dia.	E2SS-MT3
		160 to 200 mm dia.	E2SS-MT4
	T-groove	Not necessary (mounted directly)	
	Dovetail-groove	7 mm	E2SS-MV1
		9.4 mm	E2SS-MV2
		11.5 mm	E2SS-MV3
12.6 mm		E2SS-MV4	
E2SS-W	T-groove or dovetail-groove	-	E2SS-WV1

I/O Circuit Diagrams

NPN output

E2SS- □C1(-M1J/-P1)

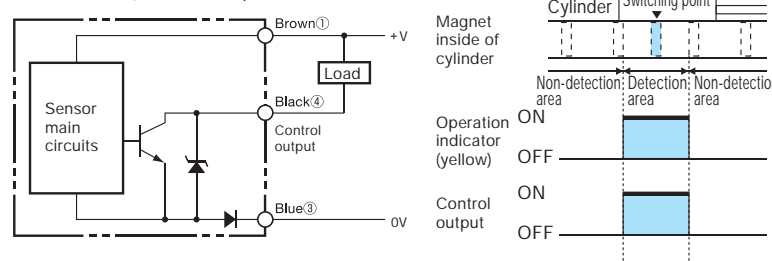

E2SS- □C1(-M1J/-P1)

E2SS- □B1(-M1J/-P1)

Symbol	Meaning
M	Standard model
W	Magnetic field immune model

PNP output

E2SS- □B1(-M1J/-P1)

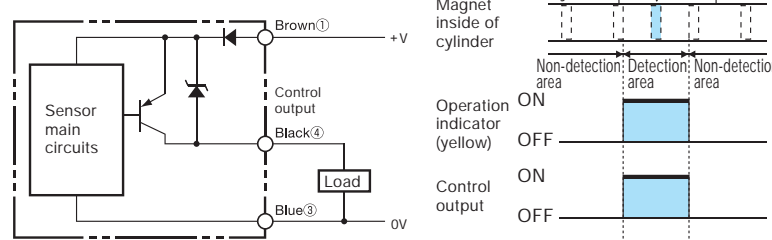

M12 Connector Pin Layout

E2SS-M□1-M1J: Pin 2 is not used.
Applicable OMRON Connecting Cable: XS2F Series



E2SS-W□1-P1: There is no pin 2.
Applicable OMRON Connecting Cable: XS2F Series



Safety Precautions

WARNING

This product is not designed or rated for ensuring safety of persons. Do not use it for such purposes.

Never use this product with an AC power supply. Otherwise, explosion may result.



NEW

Cylinder Sensor

E2SS

OMRON

Mounts to Any Type of Cylinder



OMRON Corporation Industrial Automation Company
Tokyo, JAPAN

Contact: www.ia.omron.com

Regional Headquarters

OMRON EUROPE B.V.
Sensor Business Unit
Carl-Benz-Str. 4, D-71154 Nufringen, Germany
Tel: (49) 7032-811-0/Fax: (49) 7032-811-199

OMRON ELECTRONICS LLC
One Commerce Drive Schaumburg,
IL 60173-5302 U.S.A.
Tel: (1) 847-843-7900/Fax: (1) 847-843-7787

OMRON ASIA PACIFIC PTE. LTD.
No. 438A Alexandra Road # 05-05/08 (Lobby 2),
Alexandra Technopark,
Singapore 119967
Tel: (65) 6835-3011/Fax: (65) 6835-2711

OMRON (CHINA) CO., LTD.
Room 2211, Bank of China Tower,
200 Yin Cheng Zhong Road,
PuDong New Area, Shanghai, 200120, China
Tel: (86) 21-5037-2222/Fax: (86) 21-5037-2200

Authorized Distributor:

© OMRON Corporation 2009 All Rights Reserved.
In the interest of product improvement,
specifications are subject to change without notice.

Cat. No. D109-E1-01

Printed in Japan
1009

realizing

CE

Cylinder Sensor E2SS

One shape of Sensor mounts to all types of cylinders. This greatly reduces stocked items and makes product selection easier.



Reduce Stocked Items

→ One shape of Sensor for all types of cylinders.

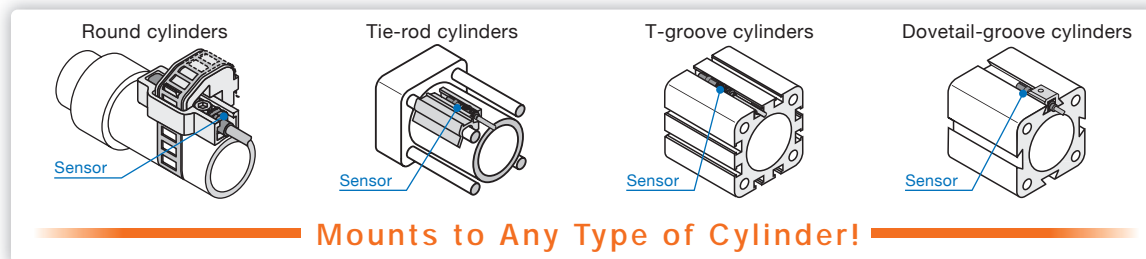

Mounts to Any Type of Cylinder!

Easier Mounting

→ Mounting is simple even in narrow spaces.



Mount the Sensor simply by turning a Hexagon-head screw approximately 90°.

Mount the Sensor using an L-shaped Hexagon wrench even in spots where a screwdriver does not fit.

Easy Onsite Operation Confirmation

→ Operating condition is confirmable at a glance.



From the Top or the Side, an Easy-to-see Operation Indicator

Just select a Mounting Bracket to mount the Sensor to any of four types of cylinders. You do not need to stock Sensors for each type of cylinder. One shape of Sensor is all that is required. This also simplifies selecting a Sensor model.

Mount the Sensor simply by turning a Hexagon-head screw approximately 90°. All you need is an L-shaped Hexagon wrench to mount the Sensor even when there is limited space above it.

*Approximately one full turn is required for some shapes of groove.

The operation indicator can be seen from a 180° view range so that you can easily check the operating condition from any angle during mounting work or during system operation.

Ratings/Performance

Standard Models: E2SS-M Series

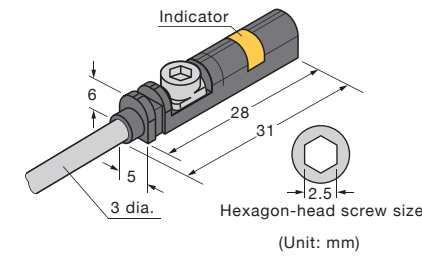

Magnetic Field Immune Models*: E2SS-W Series

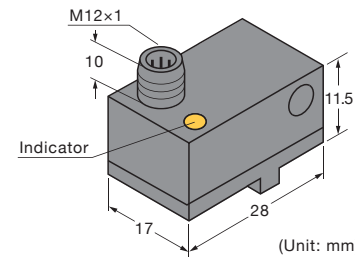

* These models prevent malfunction in environments in which AC welding is being performed. The Sensor will hold the ON or OFF control output condition when subjected to an AC magnetic field of 50 to 60 Hz and 10 to 100 mT. When the field subsides, the Sensor returns to normal operation. (Standard models will malfunction under magnetic field noise of approximately 1 mT or higher.)

Item	Model	E2SS-M Series		E2SS-W Series	
		E2SS-MC1(-M1J)	E2SS-MB1(-M1J)	E2SS-WC1-P1	E2SS-WB1-P1
Power supply voltage		10 to 30 VDC (including ripple(p-p):10%)			
Detection sensitivity (magnetic sensitivity)		2.8 mT max.			
Current consumption		15 mA max.			
Hysteresis		1 mm max.			
Repeat accuracy		±0.1 mm max.			
Pass speed		10 m/s max.		1 m/s max.	
Switching frequency		1 kHz max.		20 Hz max.	
Control output	Switching capacity	150 mA max.		100 mA max.	
	Residual voltage	2 V max. (Load current: 150 mA, Cable length: 2 m)		2 V max. (Load current: 100 mA, Cable length: 2 m)	
Indicator		Operation indicator (yellow)			
Operation mode		NPN open-collector, NO (normally open)	PNP open-collector, NO (normally open)	NPN open-collector, NO (normally open)	PNP open-collector, NO (normally open)
Protective circuits		Power supply reverse polarity protection, output reverse polarity protection, and load short-circuit protection			
Ambient temperature		Operating/Storage: -25 to 70°C (with no icing or condensation)			
Ambient humidity		Operating/Storage: 35% to 95% (with no condensation)			
Insulation resistance		50 MΩ min. (at 500 VDC) between charged parts and case			
Dielectric strength		500 VAC, 50/60 Hz for 1 min between charged parts and case			
Vibration resistance (endurance)		10 to 55 Hz with 1.0-mm double amplitude for 2 hours each in X, Y, and Z directions			
Shock resistance (endurance)		300 m/s ² 10 times each in X, Y, and Z directions			
Degree of protection		IEC 60529 IP67			
Connection method	Blank: Pre-wired (standard cable length: 2 m)			M12 connector	
	-M1J: Pre-wired M12 connector (cable length: 0.3 m)				
Weight (when packed)		Pre-wired models: Approx. 35 g Pre-wired M12 connector models: Approx. 30 g		Approx. 25 g	
Materials		Case: PP, Cable: PUR		Case: PA, Connector: PA	
Accessories		Instruction Manual, cable clip (one)		Instruction Manual, mounting screw (one)	

Applicable Cylinders and Mounting Brackets for E2SS-M Series

Cylinder	Name	Round cylinders		Tie-rod cylinders		T-groove cylinders		Dovetail-groove cylinders	
		Model	Cylinder diameter	Model	Cylinder diameter*	Model	Groove width	Model	Groove width
Mounting Bracket	Appearance	E2SS-MR1	8 to 25 mm dia.	E2SS-MT1	32 to 40 mm dia.	Not necessary (mounted directly)		E2SS-MV1	7mm
		E2SS-MR2	25 to 63 mm dia.	E2SS-MT2	50 to 63 mm dia.			E2SS-MV2	9.4mm
		-	-	E2SS-MT3	80 to 100 mm dia.			E2SS-MV3	11.5mm
		-	-	E2SS-MT4*	160 to 200 mm dia.			E2SS-MV4	12.6mm
Sensor mounted to cylinder	Appearance								

*2 The E2SS-MR□ can be mounted to the cylinder tubes of some tie-rod cylinders, depending on the shape of the cylinders. When selecting the E2SS-MT□, make sure that the following condition is met for the diameter of tie-rod. E2SS-MT1: 7 mm max. E2SS-MT2: 9 mm max. E2SS-MT3: 11 mm max., and E2SS-MT4: 16 mm max.

Applicable Cylinders and Mounting Brackets for E2SS-W Series

Cylinder	Name	T-groove cylinders		Dovetail-groove cylinders	
		Model	Groove width	Model	Groove width
Mounting Bracket	Appearance	E2SS-WV1			
Sensor mounted to cylinder	Appearance				

Switching point

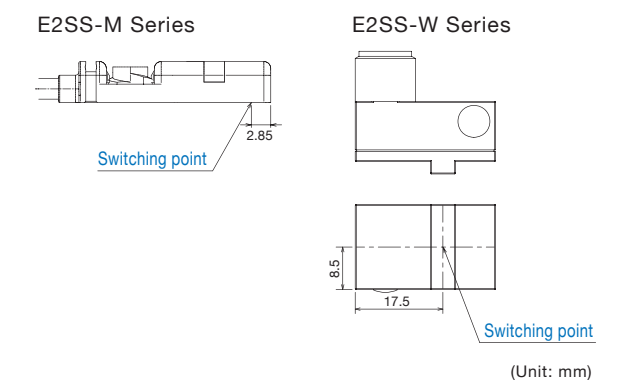

Cylinder Sensor E2SS

One shape of Sensor mounts to all types of cylinders. This greatly reduces stocked items and makes product selection easier.



Reduce Stocked Items

→ One shape of Sensor for all types of cylinders.

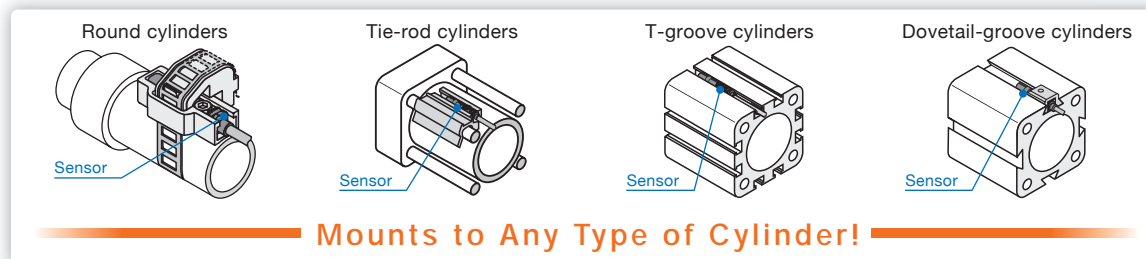

Mounts to Any Type of Cylinder!

Easier Mounting

→ Mounting is simple even in narrow spaces.



Mount in groove. Secure.

Mount the Sensor using an L-shaped Hexagon wrench even in spots where a screwdriver does not fit.

Easy Onsite Operation Confirmation

→ Operating condition is confirmable at a glance.



From the Top or the Side, an Easy-to-see Operation Indicator

Just select a Mounting Bracket to mount the Sensor to any of four types of cylinders. You do not need to stock Sensors for each type of cylinder. One shape of Sensor is all that is required. This also simplifies selecting a Sensor model.

Mount the Sensor simply by turning a Hexagon-head screw approximately 90°. All you need is an L-shaped Hexagon wrench to mount the Sensor even when there is limited space above it.

*Approximately one full turn is required for some shapes of groove.

The operation indicator can be seen from a 180° view range so that you can easily check the operating condition from any angle during mounting work or during system operation.

Ratings/Performance

Standard Models: E2SS-M Series

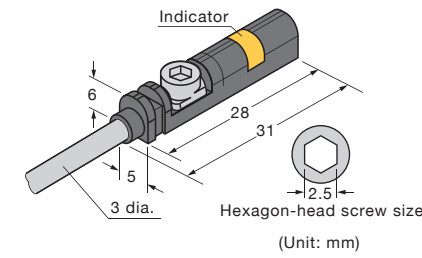

Magnetic Field Immune Models*: E2SS-W Series

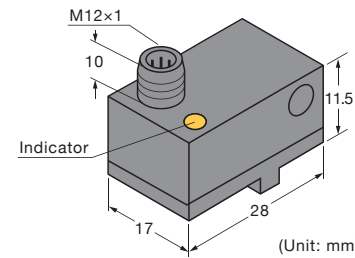

* These models prevent malfunction in environments in which AC welding is being performed. The Sensor will hold the ON or OFF control output condition when subjected to an AC magnetic field of 50 to 60 Hz and 10 to 100 mT. When the field subsides, the Sensor returns to normal operation. (Standard models will malfunction under magnetic field noise of approximately 1 mT or higher.)

Item	Model	E2SS-M Series		E2SS-W Series	
		E2SS-MC1(-M1J)	E2SS-MB1(-M1J)	E2SS-WC1-P1	E2SS-WB1-P1
Power supply voltage		10 to 30 VDC (including ripple(p-p):10%)			
Detection sensitivity (magnetic sensitivity)		2.8 mT max.			
Current consumption		15 mA max.			
Hysteresis		1 mm max.			
Repeat accuracy		±0.1 mm max.			
Pass speed		10 m/s max.		1 m/s max.	
Switching frequency		1 kHz max.		20 Hz max.	
Control output	Switching capacity	150 mA max.		100 mA max.	
	Residual voltage	2 V max. (Load current: 150 mA, Cable length: 2 m)		2 V max. (Load current: 100 mA, Cable length: 2 m)	
Indicator		Operation indicator (yellow)			
Operation mode		NPN open-collector, NO (normally open)	PNP open-collector, NO (normally open)	NPN open-collector, NO (normally open)	PNP open-collector, NO (normally open)
Protective circuits		Power supply reverse polarity protection, output reverse polarity protection, and load short-circuit protection			
Ambient temperature		Operating/Storage: -25 to 70°C (with no icing or condensation)			
Ambient humidity		Operating/Storage: 35% to 95% (with no condensation)			
Insulation resistance		50 MΩ min. (at 500 VDC) between charged parts and case			
Dielectric strength		500 VAC, 50/60 Hz for 1 min between charged parts and case			
Vibration resistance (endurance)		10 to 55 Hz with 1.0-mm double amplitude for 2 hours each in X, Y, and Z directions			
Shock resistance (endurance)		300 m/s ² 10 times each in X, Y, and Z directions			
Degree of protection		IEC 60529 IP67			
Connection method	Blank: Pre-wired (standard cable length: 2 m)			M12 connector	
	-M1J: Pre-wired M12 connector (cable length: 0.3 m)				
Weight (when packed)		Pre-wired models: Approx. 35 g Pre-wired M12 connector models: Approx. 30 g		Approx. 25 g	
Materials		Case: PP, Cable: PUR		Case: PA, Connector: PA	
Accessories		Instruction Manual, cable clip (one)		Instruction Manual, mounting screw (one)	

Applicable Cylinders and Mounting Brackets for E2SS-M Series

Cylinder	Name	Round cylinders	Tie-rod cylinders	T-groove cylinders	Dovetail-groove cylinders			
		Appearance	Model	Cylinder diameter	Model	Cylinder diameter*	Model	Groove width
Mounting Bracket	Appearance		E2SS-MR1	8 to 25 mm dia.	E2SS-MT1	32 to 40 mm dia.	E2SS-MV1	7mm
			E2SS-MR2	25 to 63 mm dia.	E2SS-MT2	50 to 63 mm dia.	E2SS-MV2	9.4mm
			-	-	E2SS-MT3	80 to 100 mm dia.	E2SS-MV3	11.5mm
			-	-	E2SS-MT4*	160 to 200 mm dia.	E2SS-MV4	12.6mm
Sensor mounted to cylinder	Appearance			Not necessary (mounted directly)				

*2 The E2SS-MR□ can be mounted to the cylinder tubes of some tie-rod cylinders, depending on the shape of the cylinders. When selecting the E2SS-MT□, make sure that the following condition is met for the diameter of tie-rod. E2SS-MT1: 7 mm max. E2SS-MT2: 9 mm max. E2SS-MT3: 11 mm max., and E2SS-MT4: 16 mm max.

Applicable Cylinders and Mounting Brackets for E2SS-W Series

Cylinder	Name	T-groove cylinders	Dovetail-groove cylinders
		Appearance	Appearance
Mounting Bracket	Name	E2SS-WV1	
Sensor mounted to cylinder	Appearance		

Switching point

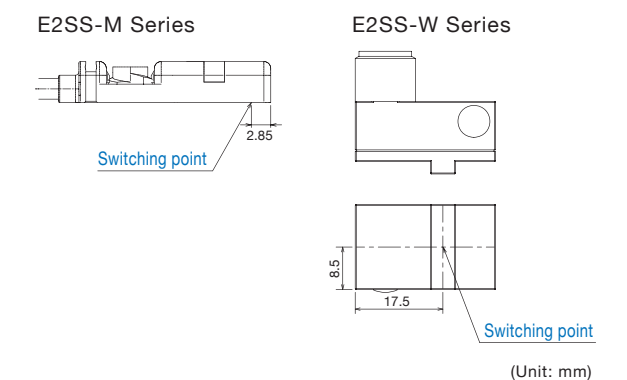

Ordering Information

Sensors

Series	Connection method	Model	
		NPN output	PNP output
E2SS-M	Pre-wired	E2SS-MC1 2M	E2SS-MB1 2M
	Pre-wired connector	E2SS-MC1-M1J 0.3M	E2SS-MB1-M1J 0.3M
E2SS-W	Connector	E2SS-WC1-P1	E2SS-WB1-P1

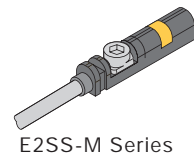

E2SS-M Series

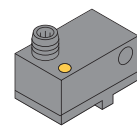

E2SS-W Series

Mounting Brackets

Series	Applicable cylinders	Cylinder diameter or groove width	Model
E2SS-M	Round	8 to 25 mm dia.	E2SS-MR1
		25 to 63 mm dia.	E2SS-MR2
	Tie-rod	32 to 40 mm dia.	E2SS-MT1
		50 to 63 mm dia.	E2SS-MT2
		80 to 100 mm dia.	E2SS-MT3
		160 to 200 mm dia.	E2SS-MT4
	T-groove	Not necessary (mounted directly)	
	Dovetail-groove	7 mm	E2SS-MV1
9.4 mm		E2SS-MV2	
11.5 mm		E2SS-MV3	
12.6 mm		E2SS-MV4	
E2SS-W	T-groove or dovetail-groove	-	E2SS-WV1

I/O Circuit Diagrams

NPN output

E2SS- □C1(-M1J/-P1)

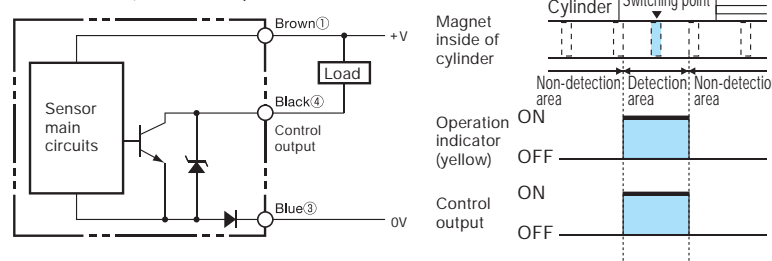

E2SS- □C1(-M1J/-P1)

E2SS- □B1(-M1J/-P1)

Symbol	Meaning
M	Standard model
W	Magnetic field immune model

PNP output

E2SS- □B1(-M1J/-P1)

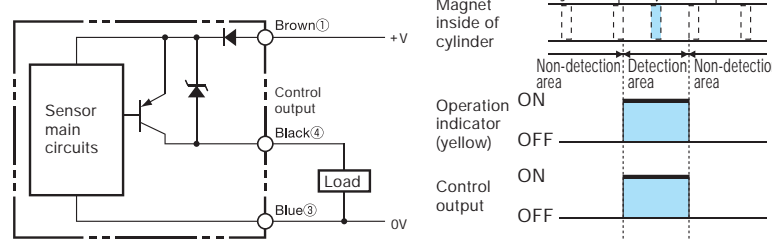

M12 Connector Pin Layout

E2SS-M□1-M1J: Pin 2 is not used.
Applicable OMRON Connecting Cable: XS2F Series



E2SS-W□1-P1: There is no pin 2.
Applicable OMRON Connecting Cable: XS2F Series



Safety Precautions

WARNING

This product is not designed or rated for ensuring safety of persons. Do not use it for such purposes.

Never use this product with an AC power supply. Otherwise, explosion may result.



NEW

OMRON

Cylinder Sensor

E2SS

Mounts to Any Type of Cylinder



OMRON Corporation Industrial Automation Company
Tokyo, JAPAN

Contact: www.ia.omron.com

Regional Headquarters
OMRON EUROPE B.V.
Sensor Business Unit
Carl-Benz-Str. 4, D-71154 Nufringen, Germany
Tel: (49) 7032-811-0/Fax: (49) 7032-811-199

OMRON ELECTRONICS LLC
One Commerce Drive Schaumburg,
IL 60173-5302 U.S.A.
Tel: (1) 847-843-7900/Fax: (1) 847-843-7787

OMRON ASIA PACIFIC PTE. LTD.
No. 438A Alexandra Road # 05-05/08 (Lobby 2),
Alexandra Technopark,
Singapore 119967
Tel: (65) 6835-3011/Fax: (65) 6835-2711

OMRON (CHINA) CO., LTD.
Room 2211, Bank of China Tower,
200 Yin Cheng Zhong Road,
PuDong New Area, Shanghai, 200120, China
Tel: (86) 21-5037-2222/Fax: (86) 21-5037-2200

Authorized Distributor:

© OMRON Corporation 2009 All Rights Reserved.
In the interest of product improvement,
specifications are subject to change without notice.
CSM_1_1_1109
Cat. No. D109-E1-01 Printed in Japan 1009

realizing

CE

X-ON Electronics

Largest Supplier of Electrical and Electronic Components

Click to view similar products for [omron](#) manufacturer:

Other Similar products are found below :

[G9ED-1-B-AQ-DC24](#) [E3X-SD11 2M](#) [S8VM-10024C](#) [R88A-CCW002P2](#) [S82Y-VM30D](#) [H3AM-NS-A AC100-240](#) [44532-2050](#) [G3NA-440B-2 DC5-24](#) [XF2J-0824-11A-R100](#) [G3NA-425B-2 DC5-24](#) [XF2J-0824-12A](#) [G8VA-1A4T-R01-DC12](#) [G8HE-1A7T-R-DC12](#) [XF2W-2415-1A](#) [XF2U-3015-3A](#) [G8V-RH-1A7T-R-DC12](#) [LY1D-2-5S-AC120](#) [CS1G-CPU43-E](#) [M22CAT1](#) [61F-GP-NT AC110](#) [M7E-01DGN2-B](#) [M7E-02DGN2](#) [M7E-08DRN2](#) [M7E-20DRN1](#) [M7E-HRN2](#) [M8PHWS](#) [D2HW-C233MR](#) [F03-02 SUS316](#) [F150LTC20](#) [F3SJ-A0245P30](#) [F3STGRNSMC21M1J8](#) [F3UVHM](#) [MG2-US-AC24](#) [MK2EP-UA-AC6V](#) [MK2PNIAC240](#) [MK310E-DC24](#) [MKS2XTIN-11 DC110](#) [MM4KPAC120NC](#) [MM4XPAC120](#) [G2Q-184P-V-DC5](#) [G2R-1114P-V-US-DC5](#) [G2R13SNDDC24](#) [G2RL-2A4-CF-DC48](#) [G2U-114P-US-DC12](#) [G2V-234P-US-DC48](#) [G3CA-8H-AC100/110/120](#) [G3PA-210B-US-DC24](#) [G3PE525B3NDC1224](#) [G3SD-Z01P-PD-US DC24](#) [G3TA-ODX02S DC24](#)