

Compact Sensor Offers Long Sensing Distance, High Noise Immunity

- Photo-IC provides long sensing distance: 15 m for through-beam, 4 m for retroreflective and 1 m for diffuse
- Integrated photo-IC improves noise immunity to interference from inverters and other inductive devices
- New injection molding technology assures IP67 rating to withstand water and dust
- Switch selectable Light-ON/Dark-ON operation
- M8 connector-ready and 2 m pre-wired models
- NPN or PNP output models available



Ordering Information

■ SENSORS

Sensing method	Light source	Appearance	Connection method	Sensing distance	Part number	
					NPN output	PNP output
Through-beam	IR		Pre-wired	15 m	E3Z-T61	E3Z-T81
			Connector		E3Z-T66	E3Z-T86
Polarized retroreflective	RED	(See Note 1.) 	Pre-wired	100 mm to 4 m 100 mm to 3 m (See Note 2.)	E3Z-R61	E3Z-R81
			Connector		E3Z-R66	E3Z-R86
Diffuse reflective	IR		Pre-wired	5 to 100 mm (wide view)	E3Z-D61	E3Z-D81
			Connector		E3Z-D66	E3Z-D86
			Pre-wired	1 m	E3Z-D62	E3Z-D82
			Connector		E3Z-D67	E3Z-D87

Note: 1. The Reflector is sold separately. Select the Reflector model most suited to the application.

2. Sensing distance can be extended to 4 meters when the E39-R1S reflector is used. The sensing distance is 3 meters when the E39-R1 reflector is used.

■ ACCESSORIES (ORDER SEPARATELY)

Slit for Through-beam Models (E3Z-T□□)

Order a slit for each emitter and receiver.

Slit width	Sensing distance (typical)	Minimum sensing object (typical)	Part number
0.5 mm dia.	50 mm	0.5 mm dia.	E39-S65A
1 mm dia.	200 mm	1 mm dia.	E39-S65B
2 mm dia.	800 mm	2 mm dia.	E39-S65C
0.5 × 10 mm	1 m	0.7 mm dia.	E39-S65D
1 × 10 mm	2.2 m	1.2 mm dia.	E39-S65E
2 × 10 mm	5 m	2.4 mm dia.	E39-S65F

Reflectors for Retroreflective Models

Name	Sensing distance (typical)	Part number
Reflector	100 mm to 3 m	E39-R1
	100 mm to 4 m	E39-R1S
	100 mm to 5 m	E39-R2
Miniature Reflector	50 mm to 1.5 m	E39-R3
Tape Reflector	150 mm to 700 mm	E39-RS1
	150 mm to 1.1 m	E39-RS2
	150 mm to 1.4 m	E39-RS3

Note: The actual sensing distance may be reduced to approximately 70% of the typical sensing distance when using a Reflector other than the E39-R1 or the E39-R1S.

Mounting Brackets

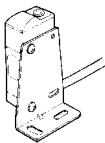
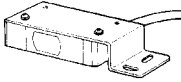
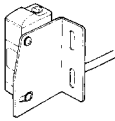
Appearance	Part number
	E39-L104
	E39-L43
	E39-L44

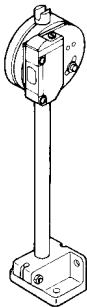
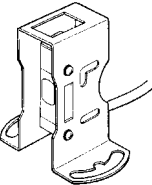
Appearance	Part number	Remarks
	E39-L93	Adjustable height and angle for sensors. Mounted to the aluminum frame rails of conveyors and adjustable with ease.
	E39-L98	Vertical protective cover bracket

Note: If a through-beam model is used, order two Mounting Brackets — one for the emitter and one for the receiver.

M8 Connectors

Appearance	Cable type	Part number
Straight	2 m (6.56 ft)	Four-wire type
	5 m (16.40 ft)	
Right angle	2 m (6.56 ft)	
	5 m (16.40 ft)	
		XS3F-M421-402-A
		XS3F-M421-405-A
		XS3F-M422-402-A
		XS3F-M422-405-A

Specifications

Item	Sensing method	Through-beam	Polarized retroreflective	Diffuse reflective	
				E3Z-D61/D66	E3Z-D62/D67
	NPN output	E3Z-T61/T66	E3Z-R61/R66		
	PNP output	E3Z-T81/T86	E3Z-R81/R86	E3Z-D81/D86	E3Z-D82/D87
Sensing distance		15 m	100 mm (4 m Note 1) (when using E39-R1S) 100 mm (3 m Note 2) (when using E39-R1)	White paper (100 × 100 mm): 100 mm	White paper (300 × 300 mm): 1 m
Standard sensing object		Opaque: 12-mm dia. min.	Opaque: 75-mm dia. min.	---	
Hysteresis		---			20% max. of setting distance
Directional angle		Both emitter and receiver: 3 to 15°	2 to 10°	---	
Light source (wave length)		Infrared LED (860 nm)	Red LED (680 nm)	Infrared LED (860 nm)	
Power supply voltage		12 to 24 VDC ±10% including 10% (p-p) max. ripple			
Current consumption		Emitter: 15 mA Receiver: 20 mA	30 mA max.		
Control output		100 mA max. at 26.4 VDC, open collector output (residual voltage: 1 V max.) L-ON/D-ON selectable			
Circuit protection		Load short-circuit and reversed power supply protection	Reversed power supply connection, output short-circuit, and mutual interference protection		
Response time		1 ms max.			
Sensitivity adjustment		One-turn adjuster			
Ambient illumination (receiver side)	Incandescent lamp	3,000 lx max.			
	Sunlight	10,000 lx max.			
Ambient temperature	Operating	-25°C to 55°C (-13°F to 131°F)			
	Storage	-40°C to 70°C (-40°F to 158°F) with no icing or condensation			
Ambient humidity	Operating	35% to 85%			
	Storage	35% to 95% with no condensation			
Insulation resistance		20 MΩ min. at 500 VDC			
Dielectric strength		1,000 VAC, 50/60 Hz for 1 min			
Vibration resistance		10 to 55 Hz, 1.5-mm double amplitude or 300 m/s ² for 2 hours each in X, Y, and Z axes			
Shock resistance	Destruction	500 m/s ² 3 times each in X, Y, and Z axes			
Enclosure rating		IP67 (IEC60529)			
Approvals		CE			
Connection method		2 m cable or M8 connector			
Indicator		Operation indicator (orange) Stability indicator (green) Emitter has power indicator (orange) only			
Weight (packed state)	Pre-wired cable (2 m)	Approx. 120 g	Approx. 65 g		
	Connector	Approx. 30 g	Approx. 20 g		
Material	Case	PBT (polybutylene terephthalate)			
	Lens	Methacrylate resin			
Accessories		Instruction manual (Order Reflector and Mounting Bracket separately.)			

- Note: 1. Sensing distance can be extended up to 4 meters when the E39-R1S reflector is used.
2. Sensing distance can be extended up to 3 meters when the E39-R1 reflector is used.

Nomenclature

Through-beam Models
E3Z-T6□ Receiver

Retroreflective Models
E3Z-R6□

Diffuse-reflective Models
E3Z-D6□

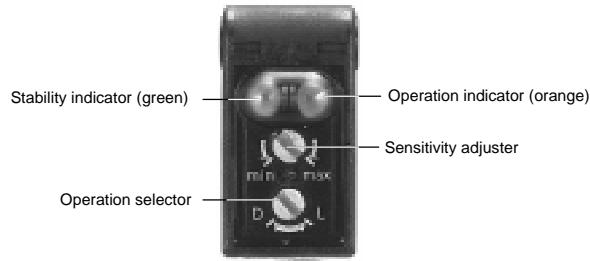

Operation

OUTPUT CIRCUITS

Model	E3Z-T61/-T66/-R61/-R66/-D61/-D66/-D62/-D67	
NPN output	Through-beam receiver Retroreflective model Diffuse reflective model	Through-beam emitter
Model	E3Z-T81/-T86/-R86/-D81/-D86/-D82/-D87	
PNP output	Through-beam receiver Retroreflective model Diffuse reflective model	Through-beam emitter
Connector pin arrangement	<p>Pin 2 is open.</p>	<p>Pins 2, 4 are open.</p>

TIMING CHARTS

Light-ON (L-ON) operation

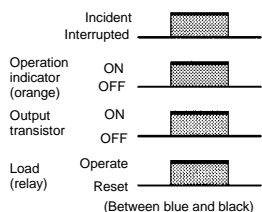

Dark-ON (D-ON) operation

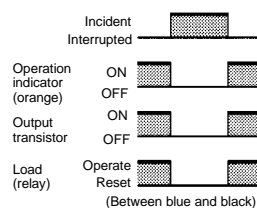

CONNECTOR PIN-OUT

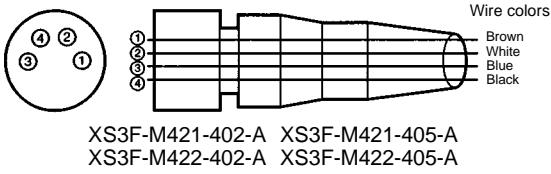

Classification	Wire color	Connector pin No.	Use
DC	Brown	①	Power supply (+V)
	White	②	Pin 2 is not used.
	Blue	③	Power supply (0 V)
	Black	④	Output

Note: The through-beam emitter does not use pins 2 and 4.

Engineering Data

PARALLEL OPERATING RANGE (TYPICAL)

Through-beam Models
E3Z-T□1 (T□6)

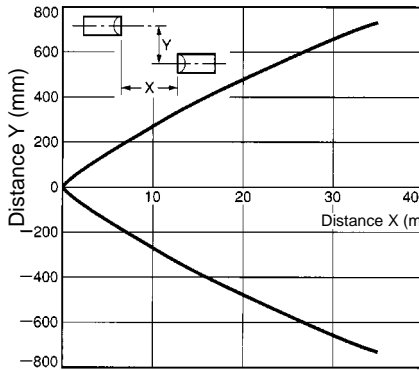

Through-beam Models
E3Z-T□1 (T□6) and Slit

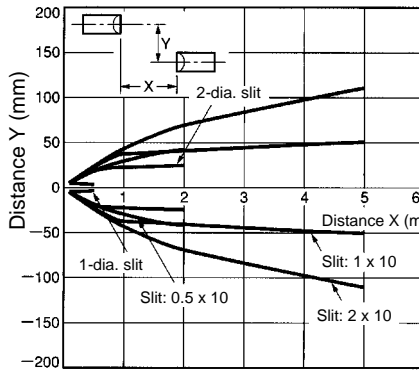

Retroreflective Models
E3Z-R□1 (R□6) and Reflector

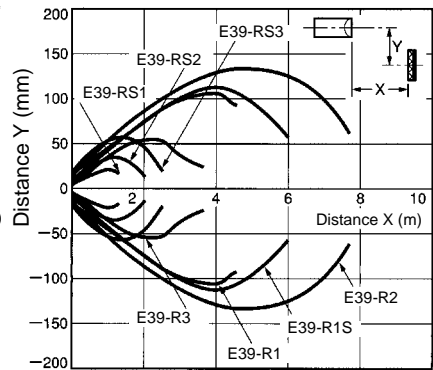

OPERATING RANGE (TYPICAL)

Diffuse Reflective Models
E3Z-D□1 (D□6)

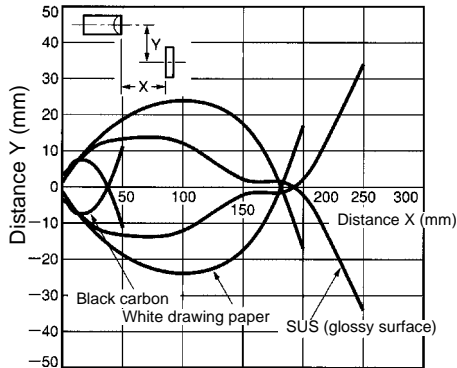

Diffuse Reflective Models
E3Z-D□2 (D□7)

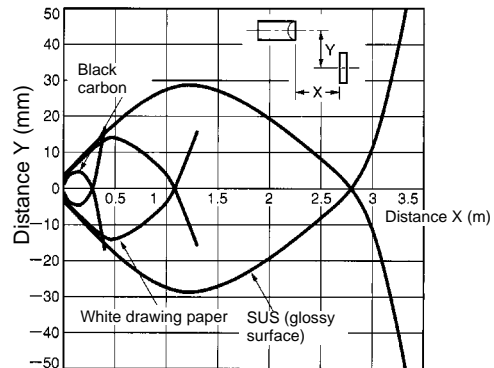

■ EXCESS GAIN RATIO VS. DISTANCE (TYPICAL)

Through-beam Models
E3Z-T□1 (T□6)

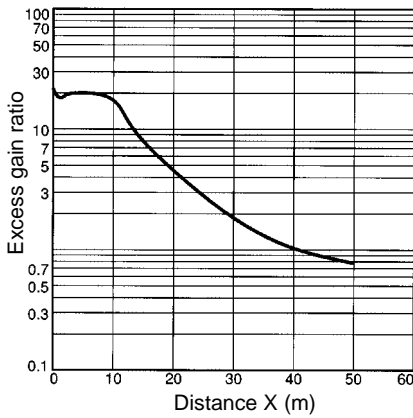

Retroreflective Models
E3Z-R□1 (R□6) and Reflector

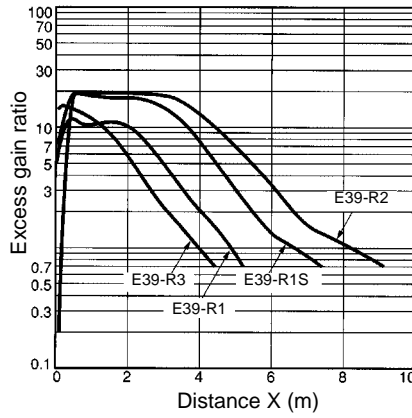

Diffuse Reflective Models
E3Z-D□1 (D□6)

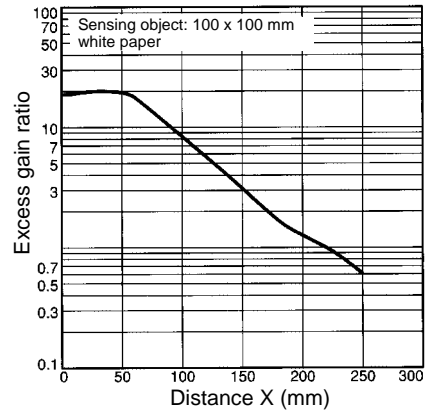

Diffuse Reflective Model
E3Z-D□2 (D□7)

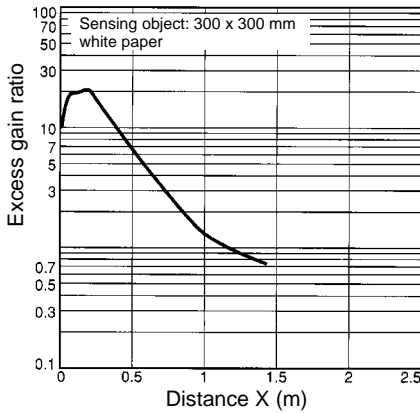

■ SENSING TARGET SIZE VS. SENSING DISTANCE (TYPICAL)

Diffuse Reflective Models
E3Z-D□1 (D□6)

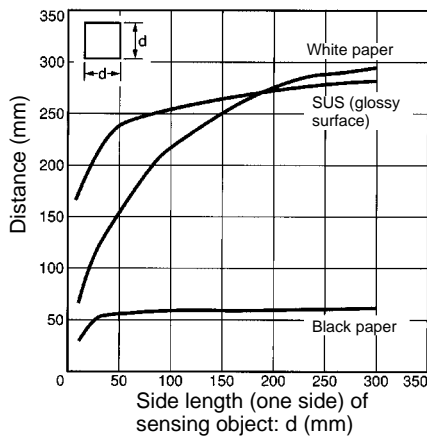

Diffuse Reflective Models
E3Z-D□2 (D□7)

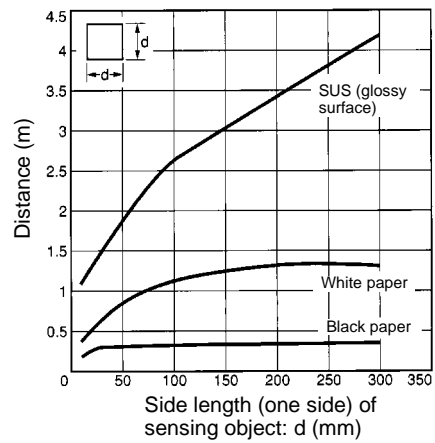

Dimensions

Unit: mm (inch)

SENSORS

Through-beam (Pre-wired Models)

E3Z-T61
E3Z-T81

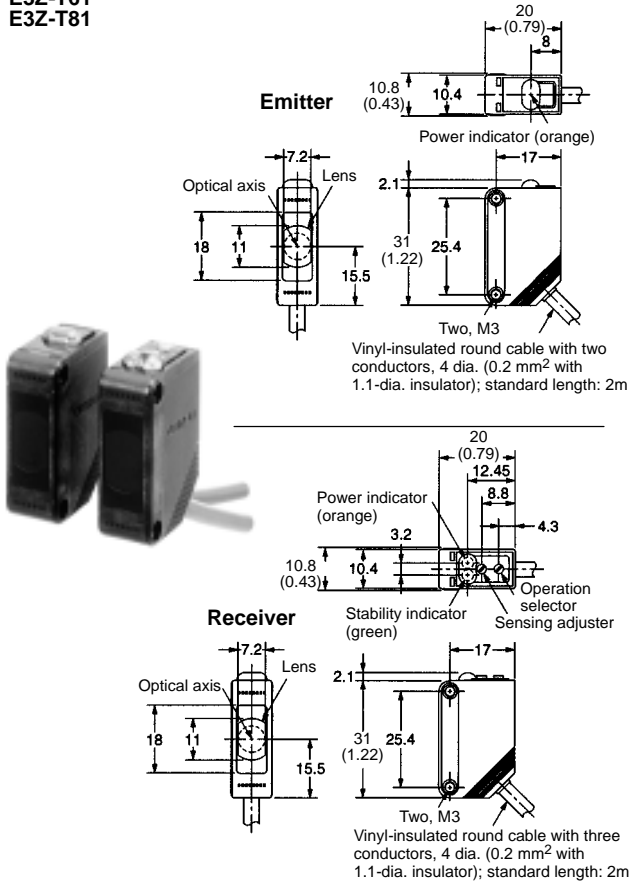

Through-beam (Connector Models)

E3Z-T66
E3Z-T86

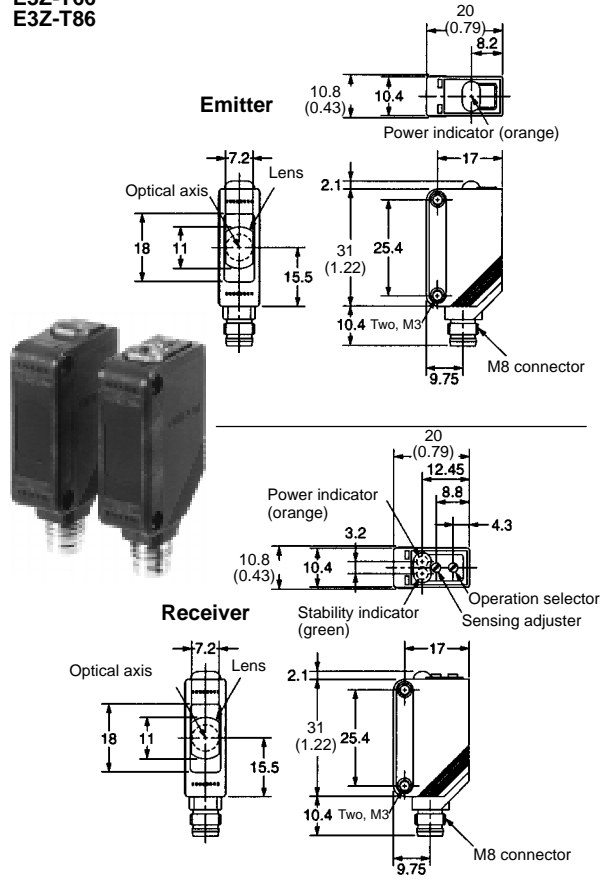

Retroreflective Models (Pre-wired Models)

E3Z-R61
E3Z-R81

Diffuse Reflective Models (Pre-wired Models)

E3Z-D61
E3Z-D62
E3Z-D81
E3Z-D82

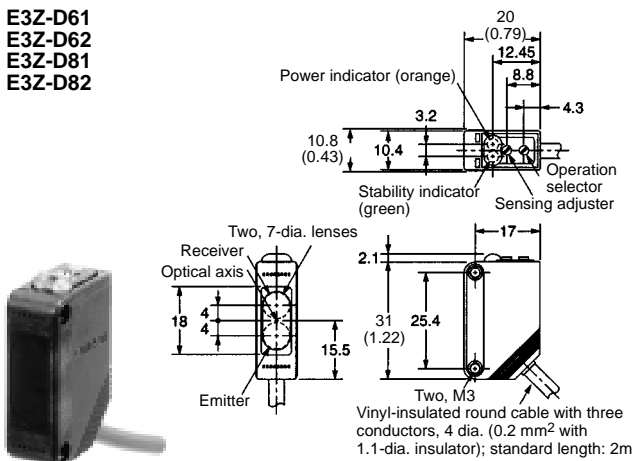

Retroreflective Models (Connector Models)

E3Z-R66
E3Z-R86

Diffuse Reflective Models (Connector Models)

E3Z-D66
E3Z-D67
E3Z-D86
E3Z-D87

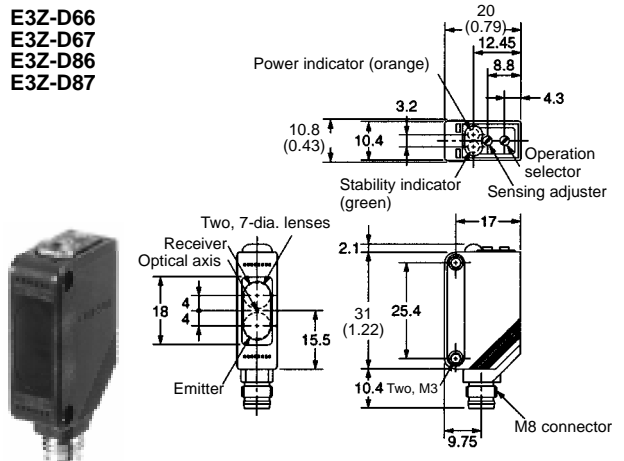

Tape Reflectors

E39-RS1

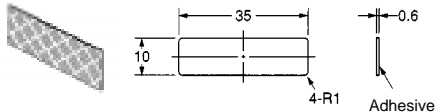

Material: Acrylic resin

E39-RS2

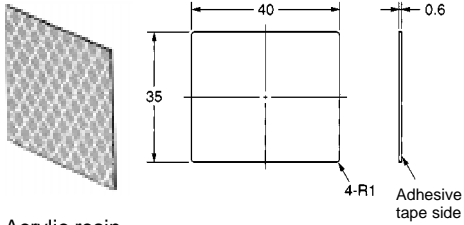

Material: Acrylic resin

E39-RS3

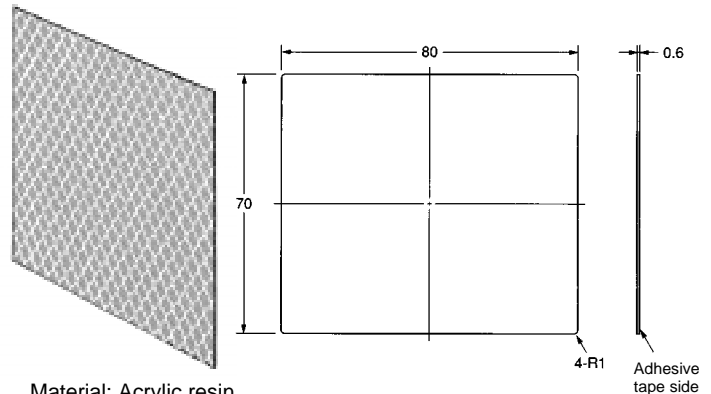

Material: Acrylic resin

Mounting Brackets

E39-L104

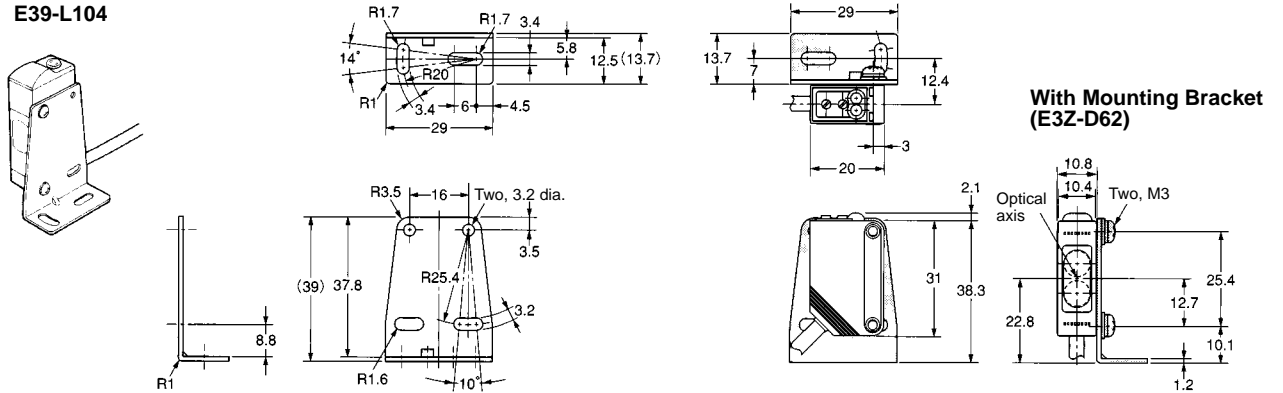

Material: SUS304 stainless steel

E39-L43

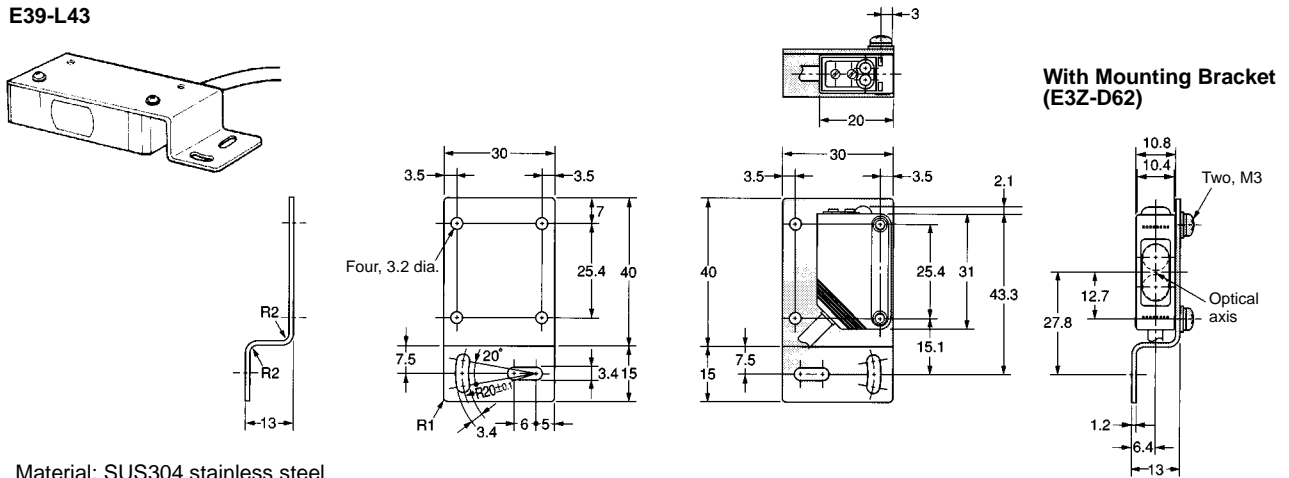

Material: SUS304 stainless steel

E39-L44

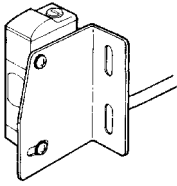

Material: SUS304 stainless steel

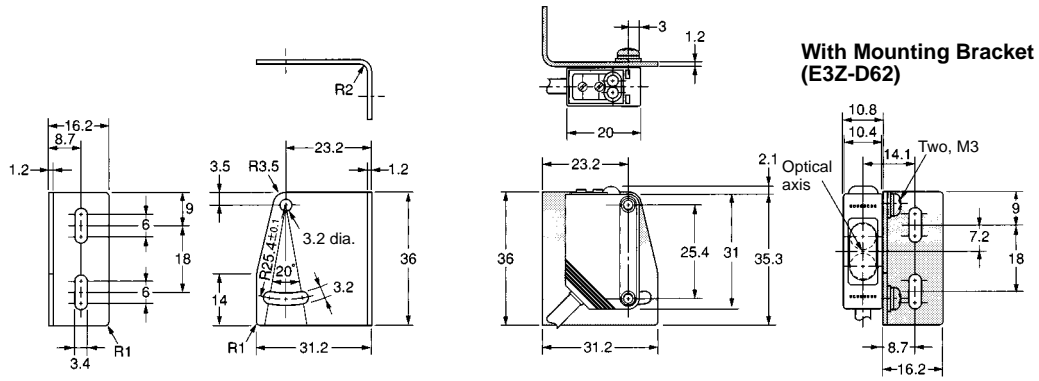

E39-L93

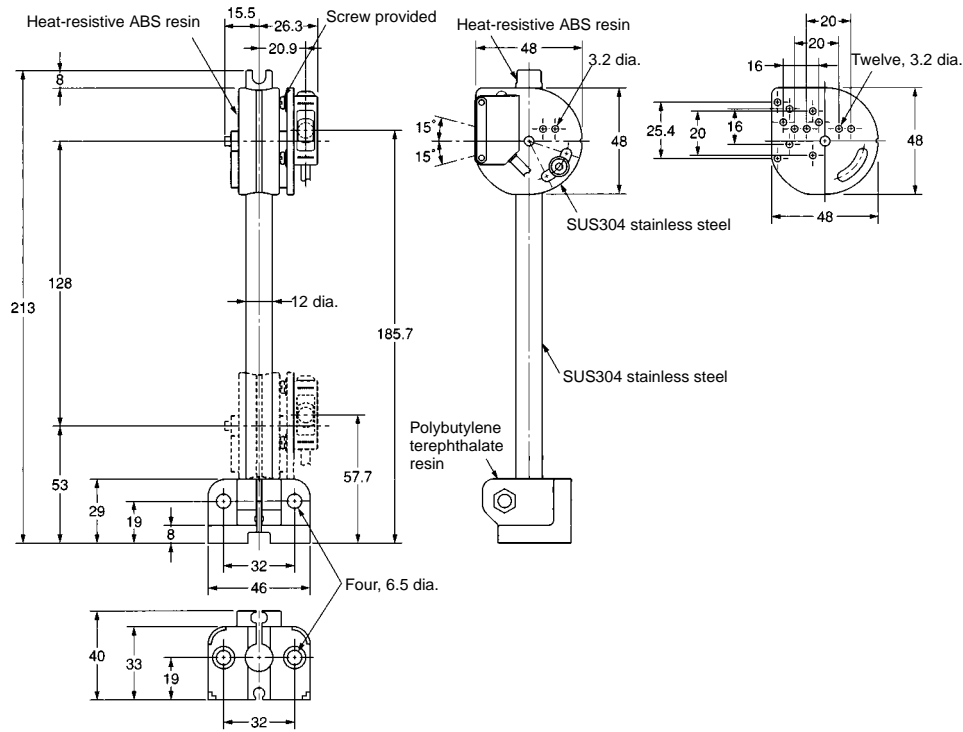
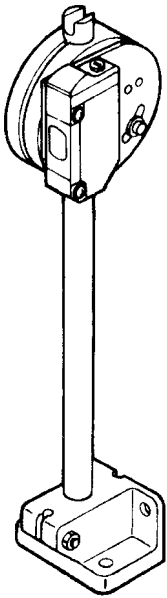

E39-L98

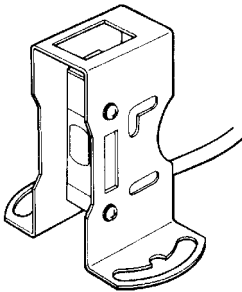

Material: SUS304 stainless steel

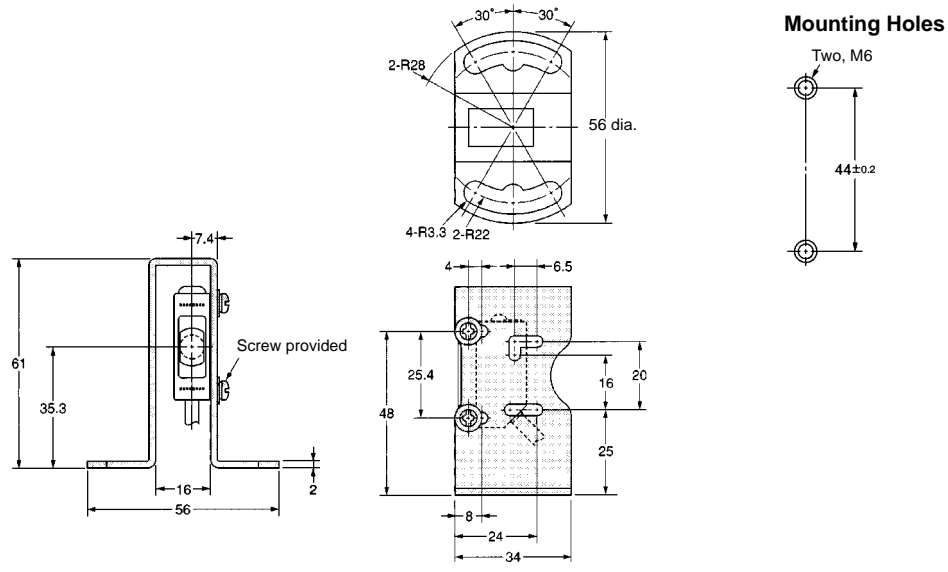

M8 Connectors

Straight

XS3F-M421-402-A (L=2 m)
XS3F-M421-405-A (L=5 m)

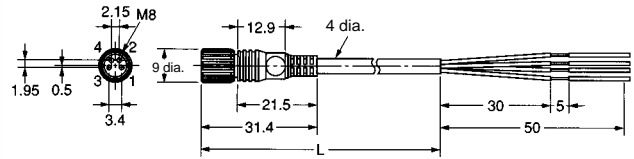

Right Angle

XS3F-M422-402-A (L=2 m)
XS3F-M422-405-A (L=5 m)

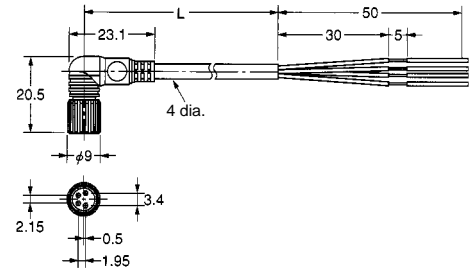

Precautions

To ensure safe sensor operation, please follow the following precautions:

■ WIRING

Power Supply Voltage

Make sure that the power supply to the Sensor is within the rated voltage range.

Load Short-circuiting

Do not short-circuit the load, or the Sensor may be damaged.

Proper Wiring

Correct polarity wiring is required in preventing damage to the sensor.

Connection Without Load

Do not connect power supply to the Sensor with no load connected, or the internal elements may explode or burn.

■ OPERATING ENVIRONMENT

Do not use the Sensor in locations with explosive or flammable gas.

■ SETTINGS

Power Reset Time

The Sensor is ready to operate 100 ms after the Sensor is turned ON. If the load and Sensor are connected to independent power supplies respectively, be sure to turn ON the Sensor before turning the load ON.

■ CONNECTIONS

M8 Metal Connector

- Turn off power before disconnecting the sensor.
- Remove the connector cover before connecting or disconnecting the metal connector.
- Secure the connector cover by hand. Do not use any pliers, or the connector may be damaged.
- The proper tightening torque range is between 0.3 and 0.4 N • m. Be sure to tighten the connector securely, or the specified degree of protection may not be maintained or the connector may be disconnected due to vibration.

■ MOUNTING

Sensor Mounting

Use M3 screws to mount the sensor and tighten each screw to a maximum torque of 0.53 N • m.

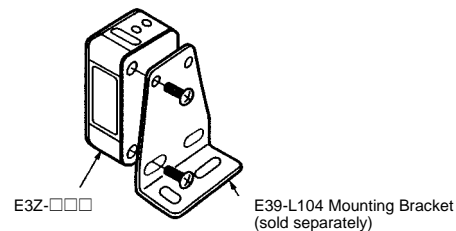

■ ADJUSTMENT

Slits for Through-beam Models (E39-S65A/B/C/D/E/F (Sold Separately))

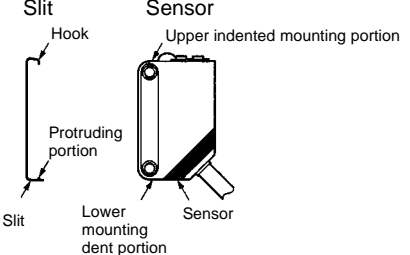
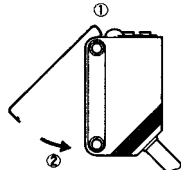
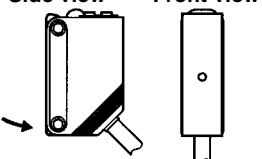
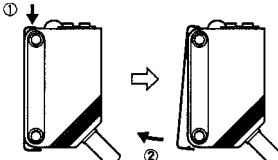
	
<p>Mounting method</p> <ol style="list-style-type: none"> Hook the upper protruding portion of the Slit to the upper indented mounting portion of the Sensor and adjust the position of the Slit so that the Slit will be in parallel to the lens side of the Sensor. Press the lower protruding portion of the Slit onto the indented mounting portion of the Sensor until the Slit snaps in. 	
<p>Mounting condition</p>	<p>Side view Front view</p> 
<p>Removal method</p> <ol style="list-style-type: none"> Press the upper portion of the Slit. Disconnect the lower protruding portion of the Slit from the Sensor and remove the Slit. 	

Terms

- **Arc Suppressor**

A simple circuit used to prevent arcing when disconnecting an inductive load. The “reverse EMF” that occurs as the magnetic field collapses can create momentary high voltages that may damage circuit components.
- **Dark-ON**

Operating mode for photoelectric sensors where the output is turned on (transistor becomes conducting, or relay coil is energized) when light is NOT received.
- **Detection Distance**

For *through-beam* type: the maximum distance from transmitter to receiver that allows the receiver to stably receive a light beam emitted from the transmitter.
For *retroreflective* type: the maximum distance from transmitter to receiver that allows the receiver to stably receive a light beam reflected from the reflector.
For *diffuse reflective* types: the maximum distance from the sensor head to a standard target that allows the sensor to stably detect a light beam reflected from the object.
- **Diffuse Reflective**

Sensor configuration with the emitter and receiver located in the same housing. Sensing of target is based on reflection of light from the target itself (rather than from a retroreflector).
- **DIN Rail**

Deutsches Institut für Normung is a non-governmental organization established to promote the development of standardization and related activities in Germany and related markets. Over 12,000 DIN standards cover a wide range of topics. The “rail” is a special fastener strip allowing the quick attachment and removal of DIN-rail-mountable items.
- **Hysteresis**

The difference between the switch-on and switch-off point for a sensor. As a target approaches the sensor, the switch-on point is closer than the switch-off point when the target is moving away from the sensor. This design feature avoids “chattering” of a sensor, where the switch-on and switch-off point are very close together. The specification is often reported as a percentage of the sensing range.
- **IEC**

International Electrotechnical Commission.
- **Inductive Load**

Load that usually contains significant inductive characteristics such as a relay coil. When switching this type of load, an arc suppressor should be used to protect the circuit from damage.
- **Infrared**

Term for light that has a longer wavelength (above 700 nm) than red light (670–700 nm). Infrared light is invisible to the human eye.
- **IP**

International Protection; an international standard scale for enclosure ratings.
- **IP66**

Approximately NEMA 4, 4X, “heavy seas” test; the enclosure is subjected to a stream of water from a 1/2” nozzle with 14 psi pressure at a distance of 1.5 meter. Water must not enter the enclosure.
- **IP67**

Approximately NEMA 6, “immersion” test; the enclosure is immersed under 1 meter of water for 30 minutes. No water may enter the enclosure.
- **kgf**

Kilogram Force.
- **Kodak 90% White Card**

A standard reference manufactured by Kodak for reflective surfaces. It is designed to reflect 90% of white light.
- **Light-ON**

Operating mode for photoelectric sensors where the output is turned on (transistor becomes conducting, or relay coil is energized) when light is received.
- **Mutual Interference Protection**

Circuitry that allows the sensor to detect and compensate for interfering signals that may be emanating from sources within its sensing range. The sensor can then operate normally, ignoring the interfering signal(s).
- **NEMA**

National Electrical Manufacturer’s Association; industrial trade organization that publishes testing standards, including enclosure ratings.
- **nm**

Nanometer; a unit of length, 10^{-9} meters, 3.937×10^{-8} inches.
- **NPN**

Transistor output designed to provide a path to ground for current passing through the load (“sinking”). When the NPN output is on, current can then pass from Positive, through the load, and through the NPN transistor to ground, completing the circuit.
- **NPT**

National Pipe Tap standard for tapered pipe threads.
- **PNP**

Transistor output that provides a path to “plus” for current passing through the load (“sourcing”). When the transistor is turned on, current can then pass from Positive, through the PNP transistor, through the load, and to ground, completing the circuit.

- **PNP**

Transistor output that provides a path to “plus” for current passing through the load (“sourcing”). When the transistor is turned on, current can then pass from Positive, through the PNP transistor, through the load, and to ground, completing the circuit.

- **Response Time**

Elapsed time from when a target moves into the sensing zone of a sensor to when the output turns on. May also refer to the “turn-off” time. The sum of turn-on and turn-off time is the total cycle time, reciprocal of switching frequency (Hz).

- **Reverse Polarity Protection**

Circuitry that prevents damage to a device if power is incorrectly connected (polarity reversed, DC). The unit may not work while polarity is reversed, but is not damaged, and will work once polarity is corrected.

- **Short-Circuit Protection**

Circuitry that prevents damage to a device’s output if the output is short-circuited.

- **Slit**

Photoelectric sensor attachment that fits over the lens, reducing the light beam size (width). This allows the sensor to detect smaller objects, but it reduces overall range.

- **Stability Indicator**

Indicates when the signal is above or below the switching threshold by a specified amount. This indicates the stability of the sensor’s ON or OFF condition.

- **Through-beam**

Sensor where the emitter and receiver are in separate housings and arranged facing each other. The target would be detected passing between the emitter and receiver, interrupting the beam.

- **Tightening Torque**

Force (rotational, “torque”) specification often reported in inch-pounds, or newton-meters. The torque is that recommended for proper tightening of a fastener (bolt, screw) to minimize loosening and to avoid damage to a fastener or to an item.

Reference Information

■ WIRE GAUGE

AWG	mm ²	Diameter (mm)	Diameter (in)
27	0.099	0.361	0.014
26	0.129	0.405	0.016
25	0.163	0.455	0.018
24	0.203	0.511	0.020
23	0.291	0.573	0.024
22	0.317	0.644	0.025
21	0.397	0.723	0.028
20	0.519	0.812	0.032
19	0.657	0.912	0.036
18	0.811	1.024	0.040
17	1.025	1.15	0.045
16	1.32	1.29	0.051
15	1.65	1.45	0.057
14	2.08	1.63	0.064
13	2.63	1.83	0.072
12	3.32	2.05	0.081

■ WAVELENGTH

Color	Wavelength
Ultraviolet	below 400 nm
Violet	400–450 nm
Blue	450–500 nm
Green	500–570 nm
Yellow	570–590 nm
Orange	590–610 nm
Red	610–700 nm
Infrared	above 700 nm

■ CONVERSIONS

Length	
1 inch = 25.4 mm	1 mm = 0.03937 inch
Force	
1 Newton = 0.2248 lb	
Time	
1μs = 10 ⁻⁶ s	
Torque	
1 kgf • m = 86.796 lbf • in	1 lbf • in = 0.01152 kgf • m
1 N • m = 8.85 in • lb	
Weight	
1 gram = 2.205 x 10 ⁻³ lbs	1 lb = 453.6 grams

NOTE: DIMENSIONS SHOWN ARE IN MILLIMETERS. To convert millimeters to inches divide by 25.4.

OMRON[®]
OMRON ELECTRONICS, INC.
One East Commerce Drive
Schaumburg, IL 60173
1-800-55-OMRON

OMRON CANADA, INC.
885 Milner Avenue
Scarborough, Ontario M1B 5V8
416-286-6465

X-ON Electronics

Largest Supplier of Electrical and Electronic Components

Click to view similar products for [Mounting Fixings](#) category:

Click to view products by [Omron](#) manufacturer:

Other Similar products are found below :

[5912235-1 REV](#) - [5912235-2](#) [007541](#) [627](#) [M3783-7001](#) [71-074914-006](#) [71-441549-19S](#) [75-69211-3P](#) [75-69214-6P](#) [75-69220-27S](#) [75-69224-5S](#) [7717-8DAP](#) [85047GULPT](#) [85048GBESR](#) [FPK-02-R10](#) [PMS27488-001-01](#) [1-18023-0](#) [H-118-2](#) [D83999/20WC8SN](#) [DB1](#)
[1302030464](#) [DC31-14W19PN](#) [DC31-14W19PW](#) [DC32-18W32SN](#) [DC36-18-32SW](#) [DC36-18-32SX](#) [DC37-14-19PW](#) [DC37-22-21PX](#)
[1302010957](#) [1302263564](#) [1302340393](#) [1404-0016-78](#) [14540](#) [149331-9811](#) [1561-60](#) [1566](#) [1566](#) [17542](#) [BR16A](#) [NT20SATT01](#)
[201C5058-01-201 REV E](#) [22594-8](#) [KBB-141](#) [915060](#) [SF4011-60101](#) [97-CS-50](#) [1671](#) [LS10215R14-15PN](#) [LS10215R14-7PN L/C](#) [1855-54](#)