

## Pressure Sensor

E8CB/E8CC

### E8CC with Built-in Microcomputer and Digital Display and New E8CB General-purpose Model

- Withstands a pressure of 490 kPa (5 kgf/cm<sup>2</sup>) and highly reliable.
- Incorporates a two-turn pressure adjuster ensuring easy pressure setting.
- E8CC: SI-compatible models are available.



## Ordering Information

Digital display	Pressure range		ON/OFF output	Linear output	Model
No	Positive pressure	0 to 98 kPa (0 to 1 kgf/cm <sup>2</sup> )	NPN open collector	1 to 5 V	E8CB-01C
	Negative pressure	0 to -101 kPa (0 to -76 cmHg)			E8CB-CN0C2B
Yes	Positive pressure	0 to 1 kgf/cm <sup>2</sup> (0 to 98 kPa)			E8CC-01C
	Negative pressure	0 to -76 cmHg (0 to -101 kPa)			E8CC-CN0C2B
	Positive pressure	0 to 10 kgf/cm <sup>2</sup> (0 to 980 kPa)			E8CC-10C
	Positive pressure	0 to 98 kPa			E8CC-A01C
	Negative pressure	0 to -101 kPa			E8CC-AN0C
	Positive pressure	0 to 980 kPa			E8CC-B10C

## Specifications

### ■ Ratings/Characteristics

Item/Model		E8CB-01C	E8CB-CN0C2B (see note 2)	E8CC-01C	E8CC-CN0C2B (see note 2)	E8CC-10C	E8CC-A01C	E8CC-AN0C (see note 2)	E8CC-B10C
Supply voltage		12 to 24 VDC ±10% with a ripple (p-p) of 5% max.							
Current consumption		20 mA max.		30 mA max.					
Pressure type		Gauge pressure							
Permissible pressure range (see note 2)	Display value	0 to 1 kgf/cm <sup>2</sup>	0 to -76 cmHg	0 to 1 kgf/cm <sup>2</sup>	0 to -76 cmHg	0 to 10 kgf/cm <sup>2</sup>	0 to 98 kPa	0 to -101 kPa	0 to 980 kPa
	Reference value	(0 to 98 kPa)	(0 to -101 kPa)	(0 to 98 kPa)	(0 to -101 kPa)	(0 to 980 kPa)	---	---	---
Pressure setting range (see note 2)	Display value	0 to 1 kgf/cm <sup>2</sup>	0 to -76 cmHg	0 to 1 kgf/cm <sup>2</sup>	0 to -76 cmHg	0 to 10 kgf/cm <sup>2</sup>	0 to 98 kPa	0 to -101 kPa	0 to 980 kPa
	Reference value	(0 to 98 kPa)	(0 to -101 kPa)	(0 to 98 kPa)	(0 to -101 kPa)	(0 to 980 kPa)	---	---	---
Pressure indication unit		---		kgf/cm <sup>2</sup>	cmHg	kgf/cm <sup>2</sup>	kPa		
Withstand pressure		490 kPa (5 kgf/cm <sup>2</sup> )				1.5 MPa (15 kgf/cm <sup>2</sup> )	490 kPa		1.5 MPa

Item/Model	E8CB-01C	E8CB-CN0C2B (see note 2)	E8CC-01C	E8CC-CN0C2B (see note 2)	E8CC-10C	E8CC-A01C	E8CC-AN0C (see note 2)	E8CC-B10C	
Applicable material	Noncorrosive and nonflammable gases								
Repeat accuracy (ON/OFF output)	±1% FS max.								
Accuracy (linear output)	±3% FS max.								
Differential travel (ON/OFF output)	2% FS max.								
Linearity (linear output)	±1% FS max.								
Response time	5 ms max.								
Linear output	1 to 5 V with an output impedance of 20 Ω and a permissible resistive load of 10 kΩ min.								
ON/OFF output	NPN open collector								
	Load current	80 mA max.							
	Output applied voltage	30 VDC max.							
	Residual voltage	1 V max. (with a load current of 80 mA) and 0.4 V max. (with a load current of 20 mA)							
Circuit protection	Reversed power supply connection and load short-circuiting								
Display (see note 1)	Red LED ON with output transistor turned ON		2 <sup>1</sup> / <sub>2</sub> -digit display Red LED ON with output transistor turned ON						
Display accuracy	---		±3% FS ± 1 digit max. (within a temperature range between 0°C and 50°C)						
			±4% FS ± 1 digit max. (within a temperature range between 50°C and 55°C)						
			±5% FS ± 1 digit max. (within a temperature range between 0°C and -10°C)						
Ambient temperature	Operating: -10°C to 55°C (with no icing) Storage: -25°C to 70°C (with no icing)								
Ambient humidity	Operating/Storage: 35% to 95% (with no icing)								
Temperature influence	±0.12% FS/°C between 0°C and 50°C and ±0.2% FS/°C max. between -10°C and 0°C or 50°C and 55°C								
Voltage influence	±1.5% FS max.								
Insulation resistance	50 MΩ min. (at 500 VDC) between current carrying parts and case								
Dielectric strength	1,000 VAC for 1 min								
Vibration resistance (destruction)	10 to 500 Hz, 1.5-mm double amplitude or 100 m/s <sup>2</sup> (10G) for 2 hours each in X, Y, and Z directions								
Shock resistance (destruction)	1,000 m/s <sup>2</sup> (100G) 3 times each in X, Y, and Z directions								
Degree of protection (see note 3)	IEC60529 IP50								
Pressure port	Aluminum								
Connection method	Prewired (standard cord length: 2 m)								
Weight	Approx. 70 g			Approx. 80 g					
Pressure port	R (PT) 1/8 and M5 female screws								

Note: 1. The 2<sup>1</sup>/<sub>2</sub>-digit display refers to a display in which the third digit displays only 0 or 1.

3rd digit    2nd digit    1st digit

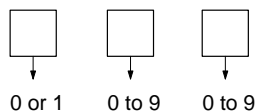

2. These models are negative-pressure models.
3. The E8CB or E8CC is not oil- or water-resistant.

# Engineering Data

**Temperature vs. Linear Output Fluctuation (Typical)**

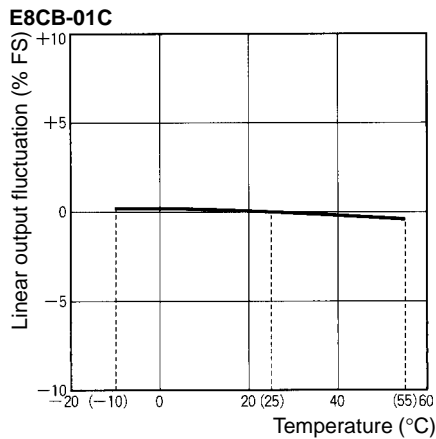

**Pressure vs. Linear Output Voltage (Typical)**

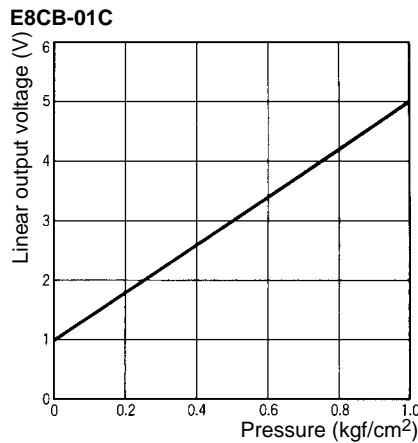

**Temperature vs. Operating Pressure (Typical)**

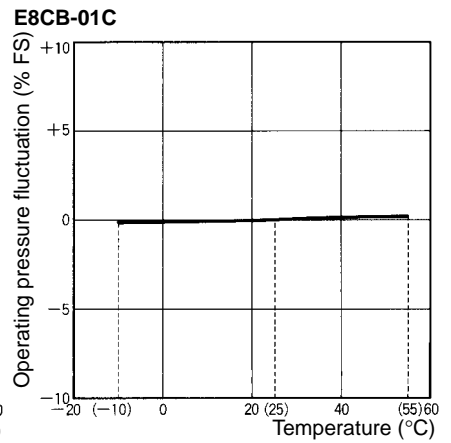

**Linearity (Typical)**

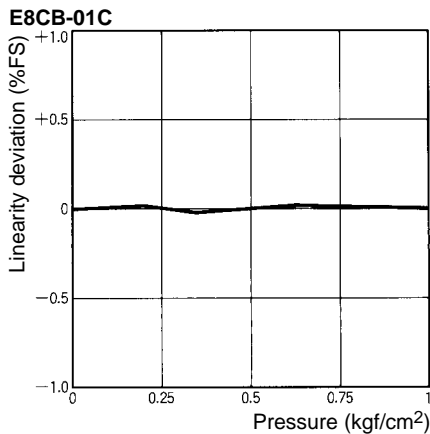

**Voltage vs. Operating Pressure Fluctuation (Typical)**

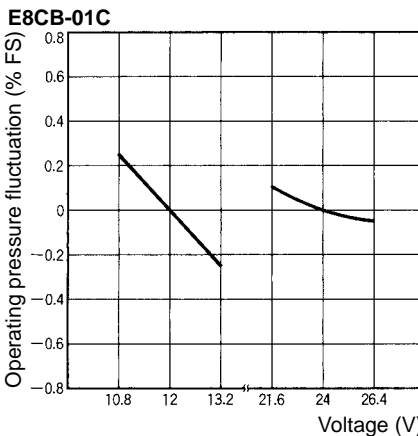

**Voltage vs. Linear Output Fluctuation (Typical)**

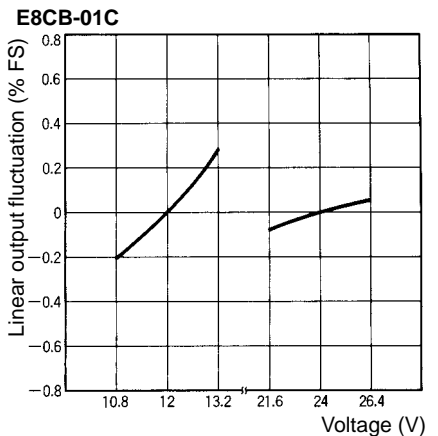

**Temperature vs. Linear Output Fluctuation (Typical)**

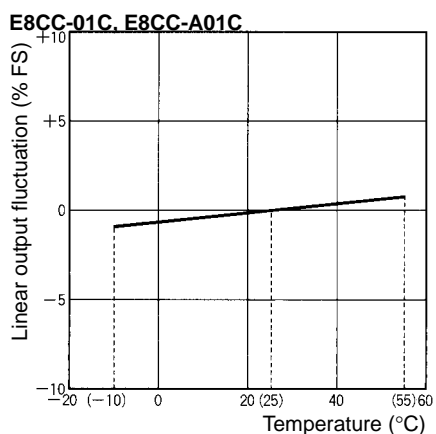

**Pressure vs. Linear Output Voltage (Typical)**

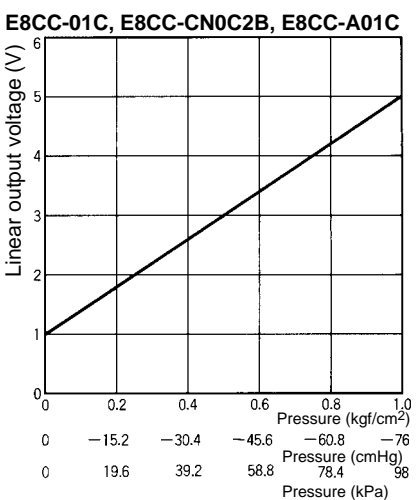

**Temperature vs. Operating Pressure (Typical)**

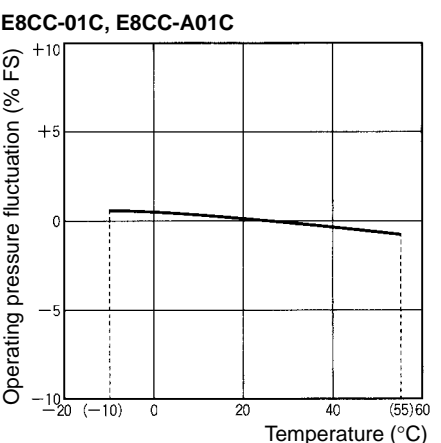

Linearity (Typical)

E8CC-01C, E8CC-A01C

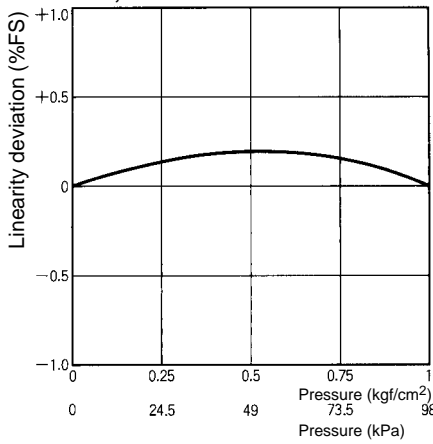

Voltage vs. Operating Pressure Fluctuation (Typical)

E8CC-CN0C2B, E8CC-AN0C

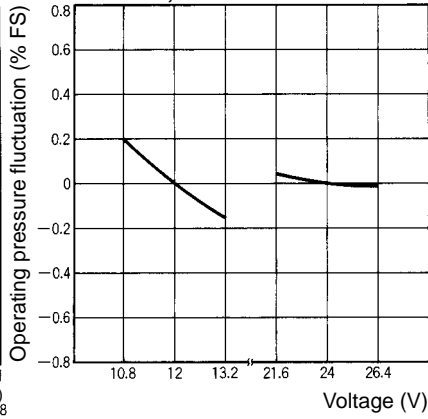

Voltage vs. Linear Output Fluctuation (Typical)

E8CC-CN0C2B, E8CC-AN0C

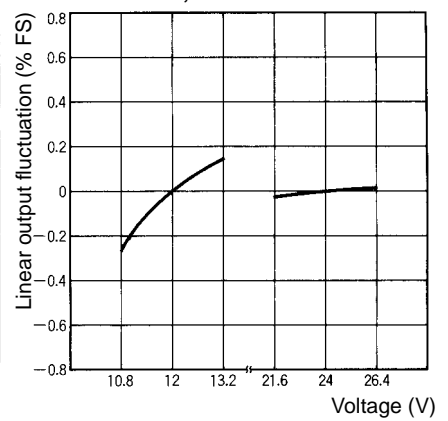

Operation

Output configuration	Model	Timing Charts	Output Circuits
NPN output	E8CB-01C, E8CC-A01C, E8CC-01C, E8CC-B10C, E8CC-10C	<p>Pressure (kgf/cm²) Setting</p> <p>Output ON/OFF</p> <p>Indicator ON/OFF</p>	<p>Operation indicator</p> <p>Main circuit</p> <p>Brown</p> <p>White (ON/OFF)</p> <p>Black (linear output)</p> <p>Blue</p> <p>+V</p> <p>0V</p> <p>Load</p> <p>Load</p>
	E8CB-CN0C2B, E8CC-AN0C, E8CC-CN0C2B	<p>Pressure (cmHg) Setting</p> <p>Output ON/OFF</p> <p>Indicator ON/OFF</p>	

## Correct Use

### ■ Adjustment (E8CC)

1. Set the mode selector to SET.



2. Turn the pressure adjuster to the desired pressure.

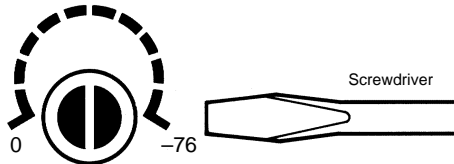

3. Set the mode selector to RUN.



The E8CC has, however, normal output in SET mode. Change in pressure setting is possible in RUN mode by turning the pressure adjuster. Do not turn the pressure adjuster after the pressure adjuster has been set to the desired pressure.

### ■ Indication

Display	Mode	Operating status	Description	Permissible range		
				Positive pressure		Negative pressure
				E8CC-A01C E8CC-01C	E8CC-B10C E8CC-10C	E8CC-AN0C E8CC-CN0C2B
30 (for 30 kPa)	RUN	Normal	Displays the imposed pressure within the permissible range.	0 to 98 kPa (0 to 1 kgf/cm <sup>2</sup> )	0 to 980 kPa (0 to 10 kgf/cm <sup>2</sup> )	0 to -101 kPa (0 to -76 cmHg)
	SET	Normal	Displays the ON-point setting pressure within the permissible range			
⚠⚠	RUN	Abnormal pressure imposition	Positive Pressure: Indicates that the imposed pressure is lower than the permissible range. Negative Pressure: Indicates that the imposed pressure is higher than the permissible range. The E8CC is, however, in normal output operation in both cases.			
	SET	Abnormal pressure setting	Positive Pressure: Indicates that ON-point setting pressure value is lower than the permissible range. Negative Pressure: Indicates that ON-point setting pressure is higher than the permissible range. The E8CC is, however, in normal output operation in both cases.			
FF	RUN	Abnormal pressure imposition	Indicates that the imposed pressure is higher than the permissible range.			---
	SET	Abnormal pressure setting	Positive Pressure: Indicates that ON-point setting pressure value is higher than the permissible range. Negative Pressure: Indicates that ON-point setting pressure is lower than the permissible range. The E8CC is, however, in normal output operation in both cases.			0 to -101 kPa (0 to -76 cmHg)
LE	RUN	Load overcurrent	Indicates that the output transistor has excessive load current, in which case, the output of the E8CC is turned OFF and this display flashes until the condition returns to normal. Check the output wiring if this display flashes.			
	SET					
SH	RUN	Element destruction	Indicates that the Pressure Sensor element is damaged due to the imposition of excessive pressure or other reasons, in which case, the output of the E8CC is turned OFF. If this display appears, the E8CC can no longer be used.			
	SET					

# Dimensions

Note: All units are in millimeters unless otherwise indicated.

## E8CB

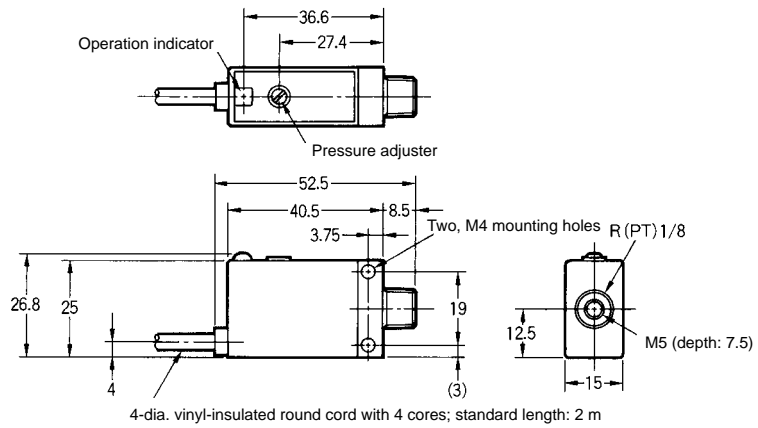
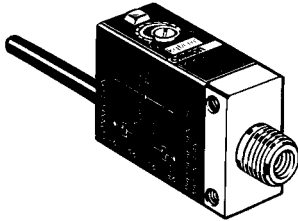

## E8CC

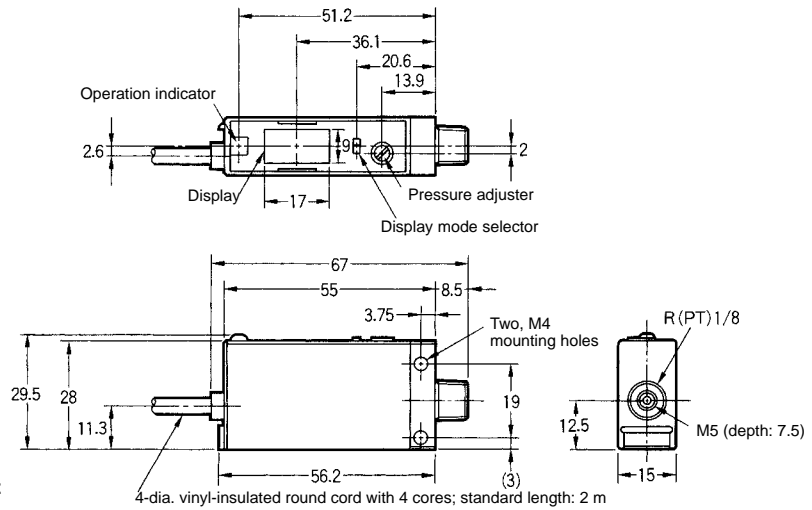
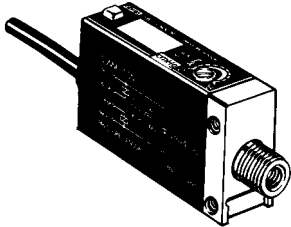

### Mounted to a DIN Track Mounting Bracket

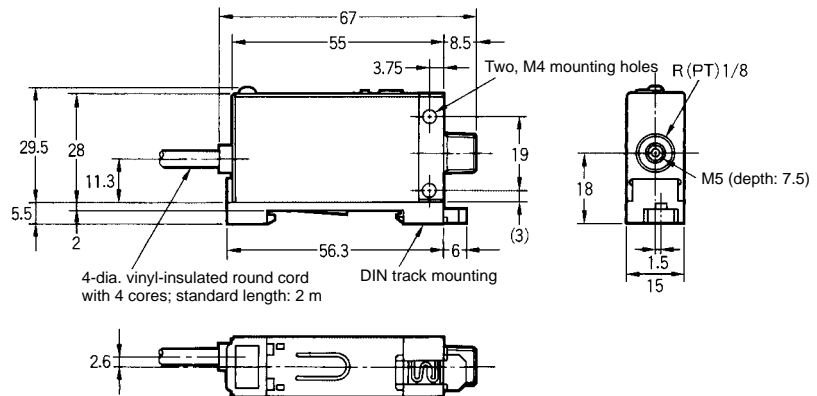
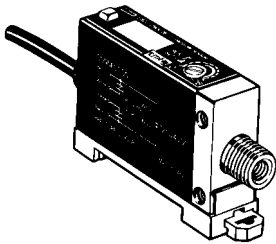

## Precautions

### ■ Mounting Diaphragm

If the diaphragm is damaged, the Pressure Sensor will not operate properly. Do not insert a screwdriver or steel wire into the interior of the pressure-sensitive parts through the pressure port.

The pressure port has an R (PT) 1/8 taper screw and M5 female screw. Apply sealing tape around the female taper screw so that no pressure leakage will occur.

Make sure that the tightening torque of the M5 female screw is 40 kgf • cm (3.9 N • m) or less.

If the Pressure Sensor is directly connected to a conduit, be sure to apply a wrench to the pressure port. Do not apply the wrench to the plastic case.

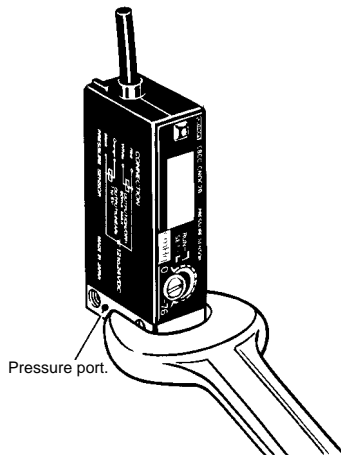

### DIN Track Mounting Bracket (E8CC)

- Mounting
  1. Fit the front part onto the bracket.
  2. Press the rear part onto the bracket.
- Removing
  3. Apply a flat-blade screwdriver to the rear hook. Then the Pressure Sensor can be removed with ease.

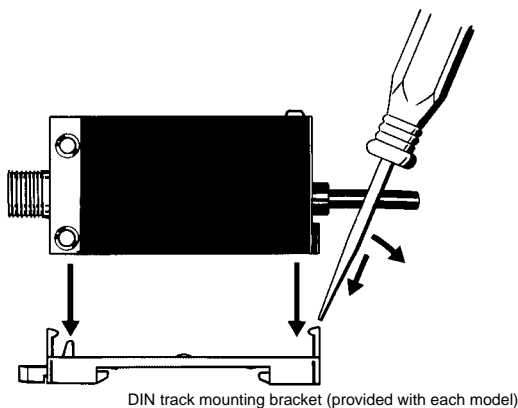

### Wiring

If no linear output is used, cut off the black lead wire and apply insulation tape to the lead wire so that it will not come in contact with any other terminal.

**ALL DIMENSIONS SHOWN ARE IN MILLIMETERS.**

To convert millimeters into inches, multiply by 0.03937. To convert grams into ounces, multiply by 0.03527.

Cat. No. D071-E1-1 **In the interest of product improvement, specifications are subject to change without notice.**

## **OMRON Corporation**

Industrial Sensors Division  
Sensing Devices and Components Division H.Q.  
28th Fl., Crystal Tower Bldg.  
1-2-27, Shiromi, Chuo-ku,  
Osaka 540-6028 Japan  
Phone: (81)6-949-6012 Fax: (81)6-949-6021

Printed in Japan  
0498-1M (0498) Ⓐ



## X-ON Electronics

Largest Supplier of Electrical and Electronic Components

*Click to view similar products for [Industrial Pressure Sensors](#) category:*

*Click to view products by [Omron](#) manufacturer:*

Other Similar products are found below :

[75380-05](#) [76053-00000300-01](#) [76053-00000300-05](#) [76061-00000015-01](#) [76062-B00000350-01](#) [76063-00000350-05](#) [76083-05000500-01](#)  
[76311-05](#) [76577-00000070-01](#) [76584-M00000100-24](#) [77343-24.0H2-01](#) [77343-25.0H2-01](#) [78291-B00000060-01](#) [78303-B00000400-01](#)  
[78303-B00000400-05](#) [78316-B00000030-01](#) [78353-B00000020-05](#) [78665-00000014-05](#) [78677-B00000070-05](#) [78678-00000040-01](#) [79279-](#)  
[00000060-01](#) [79296-B00000350-01](#) [79322-00250035-01](#) [79614-30.0H2-14](#) [79670-00000090-15](#) [79700-00002750-01](#) [79917-B00000280-01](#)  
[80569-00700100-01](#) [81509081](#) [81739-B00000900-01](#) [81807-B00000020-01](#) [MLH010BST01A](#) [MLH010BST14A](#) [MLH025BGC13B](#)  
[MLH025BSCDJ1292](#) [MLH025BSCDJ1303](#) [MLH750PSCDJ1245](#) [82903-B00000020-01](#) [83250-02500600-05](#) [83271-00000040-04](#) [83278-](#)  
[B00000200-21](#) [83286-00000150-01](#) [83299-00000150-05](#) [83303-00000600-01](#) [83305-00001350-01](#) [83330-00000100-01](#) [83349-00001470-24](#)  
[83350-04.0HG-05](#) [83350-15.0H2-05](#) [83357-00000030-21](#)