

Camera & Software Vision Package

- Built-in high-quality image processing in a PC system
- Resolving a variety of applications with highly robust and advanced measurement algorithm
- Gigabit Ethernet camera that can be connected to the FJ application software (the connectivity tested and verified)
- Building a machine vision using a customized sample in no time

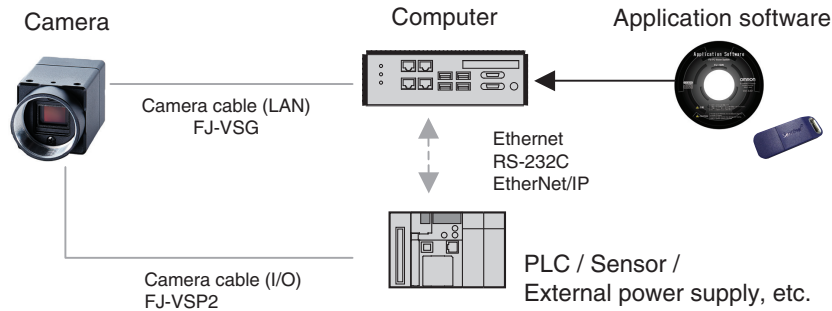

System Configuration



Ordering Information

Type		Model		Operating environment	
Camera & Software Vision Package • Application software × 1 license (CD-ROM × 1, Dongle key × 1) • Camera × 1 unit		400,000 pixels	Monochrome	FJ-SG2-S	<ul style="list-style-type: none"> • CPU: Intel Pentium Processor (SSE2 or higher) • OS: Windows 7 Professional (32/64bit) or Enterprise (32/64bit) or Ultimate (32/64bit), Windows 10 (32/64bit) • .NET Framework: .NET Framework 3.5 SP1 or higher • Memory: At least 2 GB RAM • Available disk space: At least 2 GB • Camera interface: Ethernet 1000BASE-T • Display: XGA (1024 × 768), True Color (32-bit) or higher • Optical drive: CD/DVD drive
		400,000 pixels	Color	FJ-SCG2-S	
		2 million pixels	Monochrome	FJ-S2MG2-S	
		2 million pixels	Color	FJ-SC2MG2-S	
		5 million pixels	Monochrome	FJ-S5MG2-S	
		5 million pixels	Color	FJ-SC5MG2-S	
Camera (Single unit)		400,000 pixels	Monochrome	FJ-SG2	-
		400,000 pixels	Color	FJ-SCG2	
		2 million pixels	Monochrome	FJ-S2MG2	
		2 million pixels	Color	FJ-SC2MG2	
		5 million pixels	Monochrome	FJ-S5MG2	
		5 million pixels	Color	FJ-SC5MG2	
Tripod Mount (Optional adapter for fastening the camera with tripod screws)		-	-	TP-KWA	-
Camera cable (LAN)		Cable length: 3 m, 5 m, 10 m, 20 m, 40 m	-	FJ-VSG □M *1	-
Camera cable (Power, I/O)		Cable length: 3 m, 5 m, 10 m	-	FJ-VSP2 □M *2	-
Development environment Application Producer *3	Media only	CD-ROM	-	FH-AP1	<ul style="list-style-type: none"> • CPU: Intel Pentium Processor (SSE2 or higher) • OS: Windows 7 Professional (32/64bit) or Enterprise (32/64bit) or Ultimate (32/64bit), Windows 8 Pro (32/64bit) or Enterprise (32/64bit), Windows 8.1 Pro (32/64bit) or Enterprise (32/64bit), Windows 10 Pro (32/64bit) or Enterprise (32/64bit) The following operating environment is required to use the camera FJ-S□□□G2. Windows 7 Professional (32/64bit) or Enterprise (32/64bit) or Ultimate (32/64bit) Windows 10 (32/64bit) • .NET Framework: .NET Framework 3.5 SP1 or higher • Memory: At least 2 GB RAM • Available disk space: At least 2 GB • Browser: Microsoft® Internet Explorer 6.0 or later • Display: XGA (1024 × 768), True Color (32-bit) or higher • Optical drive: CD/DVD drive • The following operating environment is required to use the camera FJ-S□□□G2. Camera interface: Ethernet 1000BASE-T • The following software is required to customize the software: Microsoft® Visual Studio® 2008 Professional, or Microsoft® Visual Studio® 2010 Professional, or Microsoft® Visual Studio® 2012 Professional
	1 license	-	-	FH-AP1L	

*1. The boxes in the model numbers are replaced by the cable length: 3 m = 3, 5 m = 5, 10 m = 10, 20 m = 20 and 40 m = 40

*2. The boxes in the model numbers are replaced by the cable length: 3 m = 3, 5 m = 5, 10 m = 10

*3. Use the development environment Application Procedure version 6.31A or higher. The FJ-S□□G2/S□2MG2/S□5MG2 Camera cannot be used with the Application Procedure version lower than 6.31A.

Lenses

Refer to the Vision Accessory Catalog (Cat. No. Q198) for details.

Camera Model	Resolution	Recommended lens		
		Standard Lens	Telecentric Lens	Vibrations and Shocks Resistant Lens
FJ-SG2	0.4 million pixels	SV-V Series	VS-TCH Series	VS-MCA Series
FJ-SCG2				
FJ-S2MG2	2 million pixels	SV-H Series		
FJ-SC2MG2				
FJ-S5MG2	5 million pixels			
FJ-SC5MG2				

Ratings and Performance

Camera

	FJ-SCG2/SG2	FJ-SC2MG2/S2MG2	FJ-SC5MG2/S5MG2
Imaging element	Progressive scan 1/2.9" CMOS	Progressive scan 1/1.7" CMOS	Progressive scan 2/3" CMOS
Shutter	Global shutter		
Effective pixels	720 (H) × 540 (V)	1,624 (H) × 1,240 (V)	2,448 (H) × 2,048 (V)
Pixel size	6.9 (μm) × 6.9 (μm)	4.5 (μm) × 4.5 (μm)	3.45 (μm) × 3.45 (μm)
Synchronous system	Internal synchronous		
Frame rate	282.8 fps	54.6 fps	21.9 fps
Number of uptake lines	4 to 540 line	8 to 1240 line	4 to 2048 line
Gain	0 dB to +20.8 dB		
Shutter speed	1 μs to 16.777 s		
Video output	Digital 8 bit		
Trigger input	External trigger/Software trigger (Ethernet)		
External output	Strobe trigger/Trigger READY (can be configured by software)		
I/F	Gigabit Ethernet (1 Gbit/s)		
Lens mount	C mount		
Power delivery	Camera cable (LAN)	Power over Ethernet (Conform to IEEE802.3af)	
	Camera cable (power supply, I/O)	10.8 to 13.2 VDC	
Power consumption	PoE supply: 4.7 W	PoE supply: 4.9 W	PoE supply: 4.4 W
	Power and I/O connector supply: 3.7 W	Power and I/O connector supply: 4.0 W	Power and I/O connector supply: 3.6 W
Vibration resistance	10 to 150 Hz, Half amplitude 0.35 mm (Acceleration: Max. 50 m/s ²), 3 directions (X/Y/Z) 8 minutes each, 10 times		
Impact resistance	150 m/s ² , 6 directions (Up and Down, Right and Left, Back and Forth) 3 times each		
Ambient temperature	Operating: 0 to 39°C, or 64°C or less at the top of the casing	Operating: 0 to 36°C, or 64°C or less at the top of the casing	Operating: 0 to 40°C, or 64°C or less at the top of the casing
	Storage: -20 to 70°C (with no icing or condensation)		
Ambient humidity	Operating and storage: 35% to 85% (with no condensation)		
Ambient environment	No corrosive gas		
Protective structure	IEC60529 standard IP30		
Weight	Approx. 65 g		
Materials	Aluminum alloy		
Minimum cable bending radius	FJ-VSG: 27.2 mm FJ-VSP2: 43.2 mm		

Dongle key

Interface	USB 2.0
Operating current	50 mA maximum
Operating temperature/humidity	0 to 50°C / 35 to 85% (No condensation)
Storage temperature/humidity	-25 to 70°C / 35 to 85% (No condensation)
Weight	Approx. 6 g
Dimensions	Approx. 44.0 mm (L) × 16.0 mm (W) × 8.0 mm (H)

Processing Items

Group	Icon	Processing Item		
Measurement		Search	Used to identify the shapes and calculate the position of measurement objects.	
		Flexible Search	Recognizing the shapes of workpieces with variation and detecting their positions.	
		Sensitive Search	Search a small difference by dividing the search model in detail, and calculating the correlation.	
		ECM Search	Used to search the similar part of model from input image. Detect the evaluation value and position.	
		EC Circle Search	Extract circles using "round" shape information and get position, radius and quantity in high precision.	
		Shape Search II	Used to search the similar part of model from input image regardless of environmental changes. Detect the evaluation value and position.	
		Shape Search III	Robust detection of positions is possible at high-speed and with high precision incorporating environmental fluctuations, such as differences in individual shapes of the workpieces, pose fluctuations, noise superimposition and shielding.	
		EC Corner	This processing item measures a corner position (corner) of a workpiece.	
		Ec Cross	The center position of a crosshair shape is measured using the lines created by the edge information on each side of the crosshair.	
		Classification	Used when various kinds of products on the assembly line need to be sorted and identified.	
		Edge Position	Measure position of measurement objects according to the color change in measurement area.	
		Edge Pitch	Detect edges by color change in measurement area. Used for calculating number of pins of IC and connectors.	
		Scan Edge Position	Measure peak/bottom edge position of workpieces according to the color change in separated measurement area.	
		Scan Edge Width	Measure max/min/average width of workpieces according to the color change in separated measurement area.	
		Circular Scan Edge Position	Measure center axis, diameter and radius of circular workpieces.	
		Circular Scan Edge Width	Measure center axis, width and thickness of ring workpieces.	
		Intersection	Calculate approximate lines from the edge information on two sides of a square workpiece to measure the angle formed at the intersection of the two lines.	
		Color Data	Used for detecting presence and mixed varieties of products by using color average and deviation.	
		Gravity and Area	Used to measure area, center of gravity of workpieces by extracting the color to be measured.	
		Labeling	Used to measure number, area and gravity of workpieces by extracting registered color.	
		Label Data	Selecting one region of extracted Labeling, and get that measurement. Area and Gravity position can be got and judged.	
		Defect	Used for appearance measurement of plain-color measurement objects such as defects, stains and burrs.	
		Precise Defect	Check the defect on the object. Parameters for extraction defect can be set precisely.	
		Fine Matching	Difference can be detected by overlapping and comparing (matching) registered fine images with input images.	
		Character Inspect	Recognize character according correlation search with model image registered in [Model Dictionary].	
		Date Verification	Reading character string is verified with internal date.	
		Model Dictionary	Register character pattern as dictionary. The pattern is used in [Character Inspection].	
		2DCode II *1	Recognize 2D code and display where the code quality is poor.	
		2DCode *2	Recognize 2D code and display where the code quality is poor.	
		Barcode *3	Recognize barcode, verify and output decoded characters.	
		OCR	Recognize and read characters in images as character information.	
		OCR User Dictionary	Register dictionary data to use for OCR.	
		Circle Angle	Used for calculating angle of inclination of circular measurement objects.	
		Glue Bead Inspection	You can inspect coating of a specified color for gaps or runoffs along the coating path.	
	Input Image		Camera image input GigE	Capture images from a GigE camera.
			Camera Image Input HDR	Create high-dynamic range images by acquiring several images with different conditions.
			Camera Switch	To switch the cameras used for measurement. Not input images from cameras again.
			Measurement Image Switching	To switch the images used for measurement. Not input images from camera again.

Group	Icon	Processing Item		
Input Image		Multi-trigger Imaging	The Multi-trigger Imaging processing item captures multiple images at user-defined timings and executes parallel measurement for each image. Insert the Multi-trigger Imaging to the top of the flow.	
		Multi-trigger Imaging Task	The Multi-trigger Imaging processing item captures multiple images at user-defined timings and executes parallel measurement for each image. Insert this processing item to the top of the processing which requires imaging for multiple times.	
Compensate image		Position Compensation	Used when positions are differed. Correct measurement is performed by correcting position of input images.	
		Filtering	Used for processing images input from cameras in order to make them easier to be measured.	
		Background Suppression	To enhance contrast of images by extracting color in specified brightness.	
		Brightness Correct Filter	Track brightness change of entire screen and remove gradual brightness change such as uneven brightness.	
		Color Gray Filter	Color image is converted into monochrome images to emphasize specific color.	
		Extract Color Filter	Convert color image to color extracted image or binary image.	
		Anti Color Shading	To remove the irregular color/pattern by uniformizing max.2 specified colors.	
		Stripes Removal Filter II	Remove the background pattern of vertical, horizontal and diagonal stripes.	
		Polar Transformation	Rectify the image by polar transformation. Useful for OCR or pattern inspection printed on circle.	
		Trapezoidal Correction	Rectify the trapezoidal deformed image.	
		Machine Simulator	How the alignment marks would move on the image when each stage or robot axis is controlled can be checked.	
		Image Subtraction	The registered model image and measurement image are compared and only the different pixels are extracted and converted to an image.	
		Advanced filter	Process the images acquired from cameras in order to make them easier to measure. This processing item consolidates existing image conversion filtering into one processing item and adds extra functions.	
		Panorama	Combine multiple image to create one big image.	
Support measurement		Unit Macro	Advanced arithmetic processing can be easily incorporated into workflow as Unit Macro processing items.	
		Unit Calculation Macro	This function is convenient when the user wants to calculate a value using an original calculation formula or change the set value or system data of a processing item.	
		Calculation	Used when using the judge results and measured values of Proctem which are registered in processing units.	
		Line Regression	Used for calculating regression line from plural measurement coordinate.	
		Circle Regression	Used for calculating regression circle from plural measurement coordinate.	
		Precise Calibration	Used for calibration corresponding to trapezoidal distortion and lens distortion.	
		User Data	Used for setting of the data that can be used as common constants and variables in scene group data.	
		Set Unit Data	Used to change the Proctem data (setting parameters, etc.) that has been set up in a scene.	
		Get Unit Data	Used to get one data (measured results, setting parameters, etc.) of Proctem that has been set up in a scene.	
		Set Unit Figure	Used for re-setting the figure data (model, measurement area) registered in an unit.	
		Get Unit Figure	Used for get the figure data (model, measurement area) registered in an unit.	
		Trend Monitor	Used for displaying the information about results on the monitor, facilitating to avoid NG and analyze causes.	
	Support measurement		Image Logging	Used for saving the measurement images to the memory and USB memory.
			Image Conversion Logging	Used for saving the measurement images in JPEG and BMP format.
		Data Logging	Used for saving the measurement data to the memory and USB memory.	
		Elapsed Time	Used for calculating the elapsed time since the measurement trigger input.	
		Wait	Processing is stopped only at the set time. The standby time is set by the unit of [ms].	
		Focus	Focus setting is supported.	
Support measurement		Iris	Focus and aperture setting is supported.	
		Parallelize	A part of the measurement flow is divided into two or more tasks and processed in parallel to shorten the measurement time. This processing item is placed at the top of processing to be performed in parallel.	

Group	Icon	Processing Item		
Support measurement		Parallelize Task	A part of the measurement flow is divided into two or more tasks and processed in parallel to shorten the measurement time. This processing item is placed immediately before processing to be performed in parallel between Parallelize and Parallelize End.	
		Statistics	Used when you need to calculate an average of multiple measurement results.	
		Reference Calib Data	Calibration data and distortion compensation data held under other processing items can be referenced.	
		Position Data Calculation	The specified position angle is calculated from the measured positions.	
		Stage Data	Sets and stores data related to stages.	
		Robot Data	Sets and stores data related to robots.	
		Vision Master Calibration	This processing item automatically calculates the entire axis movement amount of the control equipment necessary for calibration.	
		PLC Master Calibration	Calibration data is created using a communication command from PLC.	
		Convert Position Data	The position angle after the specified axis movement is calculated.	
		Movement Single Position	The axis movement that is required to match the measured position angle to the reference position angle is calculated.	
		Movement Multi Points	The axis movements that are required to match the measured position angles to the corresponding reference position angles are calculated.	
		Detection Point	Obtains position/angle information by referring to the coordinate values measured with the Measurement Processing Unit.	
		Manual Position Setting	Used to change the measurement coordinates X and Y of the measurement processing unit.	
		Camera Calibration	By setting the camera calibration, the measurement result can be converted and output as actual dimensions.	
		Data Save	The set data can be saved in the controller main unit or as scene data. The data is held even after the FH/FZ power is turned off.	
		Conveyor Calibration	Conveyor Calibration is used to calibrate camera, conveyor, and robots for conveyor tracking application.	
		Scene	The specified scene is copied to the current scene.	
		System Information	Obtain system information (e.g., memory and disk space and I/O input signal status) of the Sensor Controller.	
	Branch		Conditional Branch	Used where more than two kinds of products on the production line need to detected separately.
			End	This Procltem must be set up as the last processing unit of a branch.
		DI Branch	Same as Procltem "Branch". But you can change the targets of conditional branching via external inputs.	
		Control Flow Normal	Set the measurement flow processing into the wait state in which the specific no-protocol command can be executed.	
		Control Flow PLC Link	Set the measurement flow processing into the wait state in which the specific PLC Link command can be executed.	
		Control Flow Parallel	Set the measurement flow processing into the wait state in which the specific parallel command can be executed.	
		Control Flow Fieldbus	Set the measurement flow processing into the wait state in which the specific Fieldbus command can be executed.	
		Selective Branch	Easily branch to multiple destinations.	
		Conditional Execution (If)	The measurement flow is divided according to the comparison result obtained using the set expressions and conditions.	
		Conditional Execution (Else)	Insert between the Conditional Execution (If) processing item and End If processing item. The measurement flow is divided according to the comparison result obtained using the set expressions and conditions.	
		Loop	The set processes are repeated until the loop count reaches the specified number, and then the next process starts.	
		Loop Suspension	Insert between the Loop processing item and End Loop processing item. Used to stop the loop before the loop count reaches the specified number.	
		Select Execution (Select)	Used to set conditions. The measurement flow is divided according to the comparison result obtained using the conditions given by expressions.	
		Select Execution (Case)	Used to make a judgment. The measurement flow is divided according to the comparison result obtained using the conditions given by expressions.	

Group	Icon	Processing Item	
Output result		Result Output (I/O)	Output data to the external devices such as a programmable controller or a PC via PLC Link, Parallel interface, Fieldbus interface (EtherCAT, EtherNet/IP (other than message communication), PROFINET).
		Result Output (Message)	Output data to the external devices such as a programmable controller or a PC with non-protocol mode via the serial interface or EtherNet/IP (message communication). This processing item allows you to save the logging data as a ".csv" file into the Sensor Controller as well.
		Data Output	Used when you need to output data to the external devices such as PLC or PC via serial ports.
		Parallel Data Output	Used when you need to output data to the external devices such as PLC or PC via parallel ports.
		Parallel Judgement Output	Used when you need to output judgement results to the external devices such as PLC or PC via parallel ports.
		Fieldbus Data Output	Outputs data to an external device, such as a Programmable Controller, through a fieldbus interface.
Display result		Result Display	Used for displaying the texts or the figures in the camera image.
		Display Image File	Display selected image file.
		Display Last NG Image	Display the last NG images.
		Conveyor Panorama Display	Display images of the tracking area as a panoramic image.
		Display Image Hold	Processing item to retain images, including measurement results.

- *1 2D Codes that can be read : Data Matrix (ECC200)
- *2 2D Codes that can be read : Data Matrix (ECC200), QR Code
- *3 Bar Codes that can be read : JAN/EAN/UPC (including add-on codes), Code 39, Codabar (NW-7), ITF (Interleaved 2 of 5), Code 93, Code 128, GS1-128, GS1 DataBar (RSS-14 / RSS Limited / RSS Expanded), Pharmacoce

External Dimensions

Camera

FJ-SG2/SCG2/S5MG2/SC5MG2

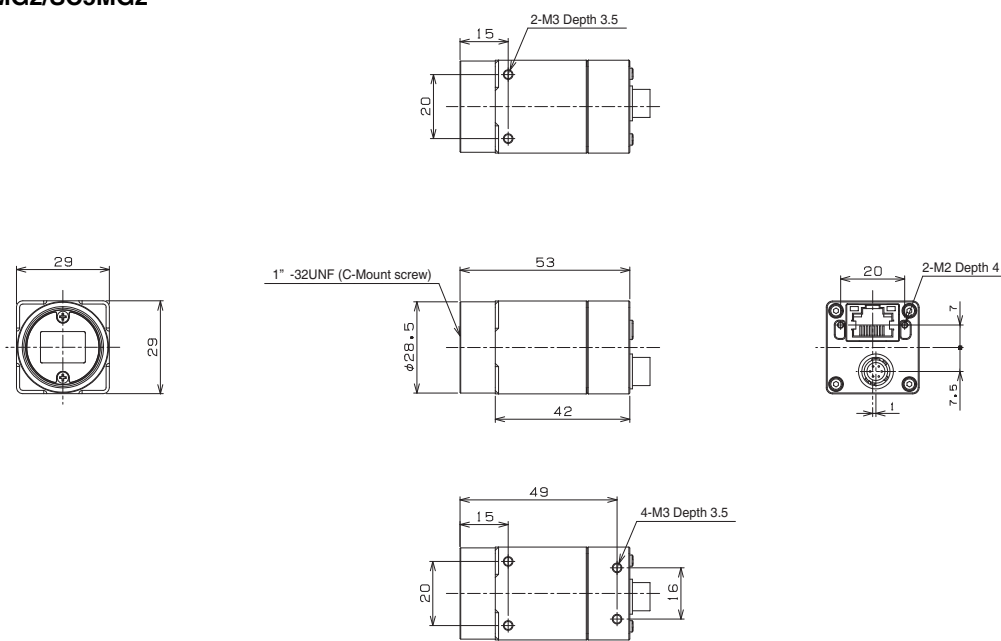

FJ-S2MG2/SC2MG2

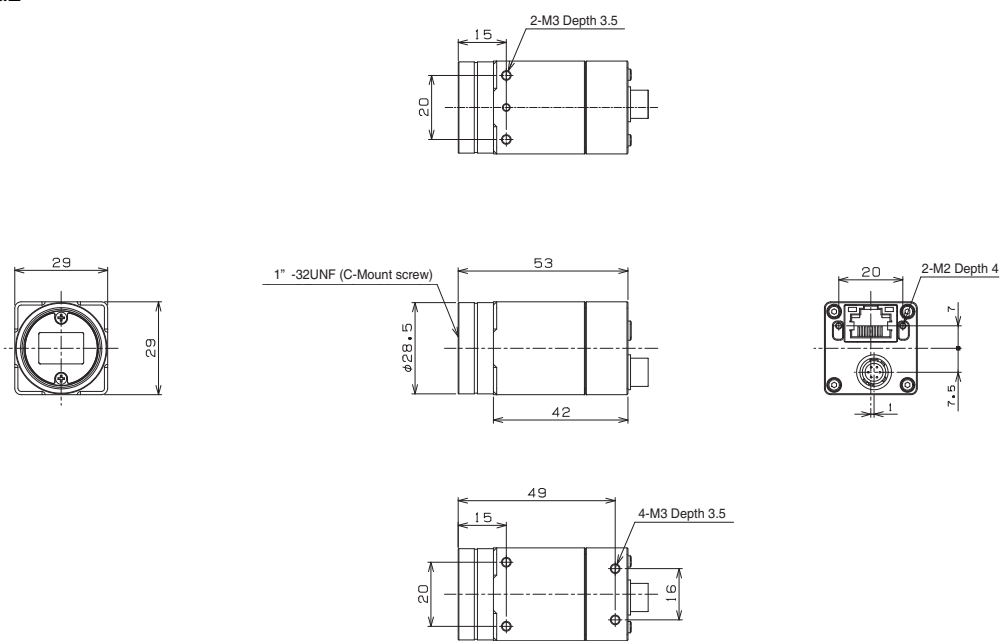

Camera cable (LAN)

FJ-VSG □□M

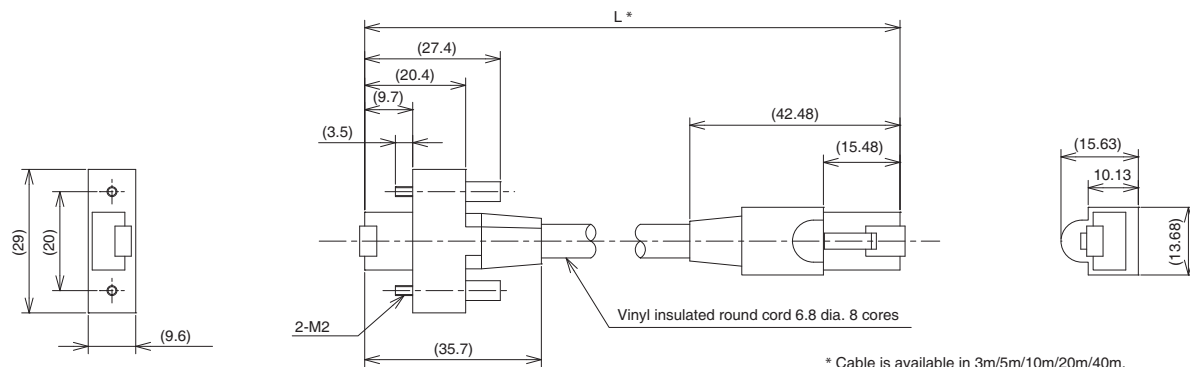

Camera cable (Power, I/O)

FJ-VSP2 □□M

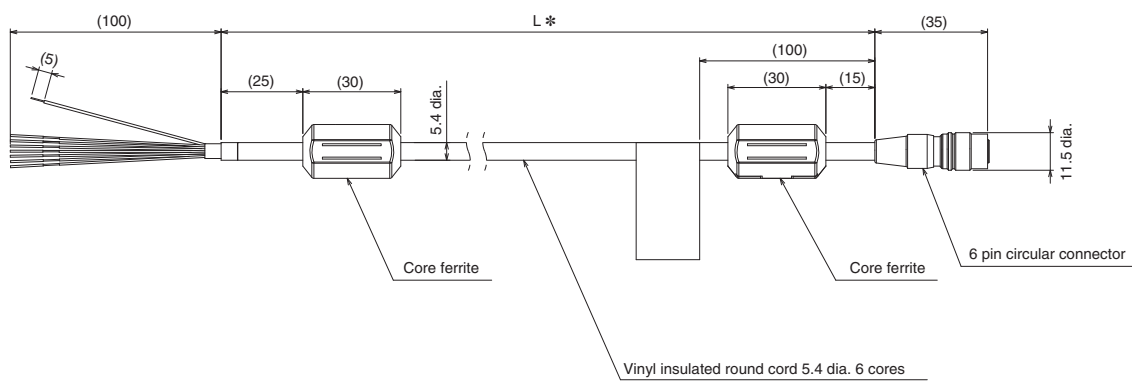

Optical Chart

400,000-pixel digital camera FJ-SCG2/SG2

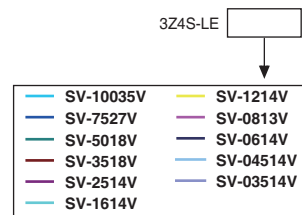
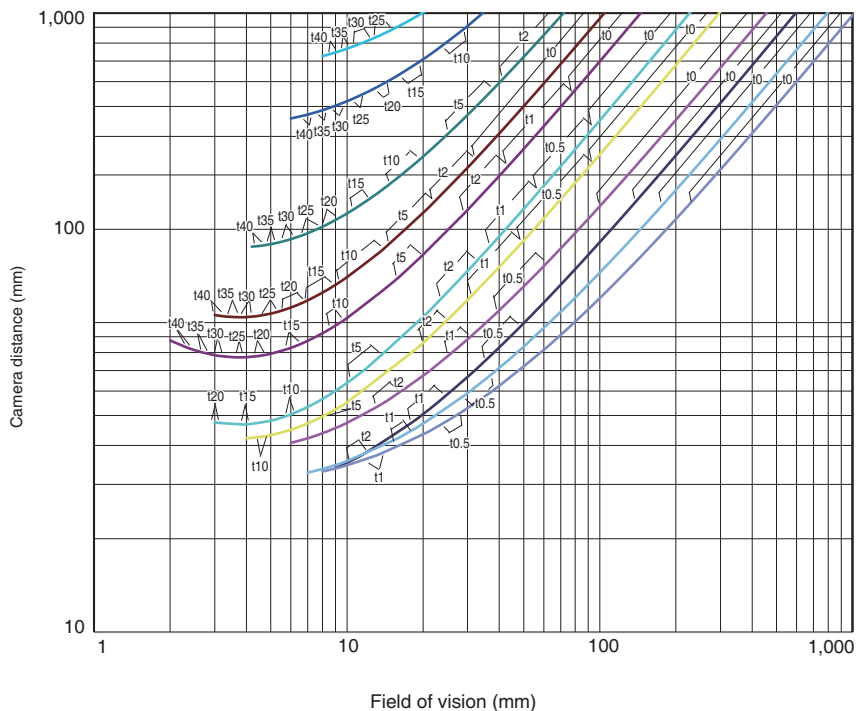

2 million-pixel digital camera FJ-SC2MG2/S2MG2

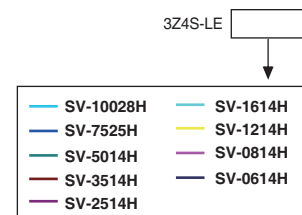
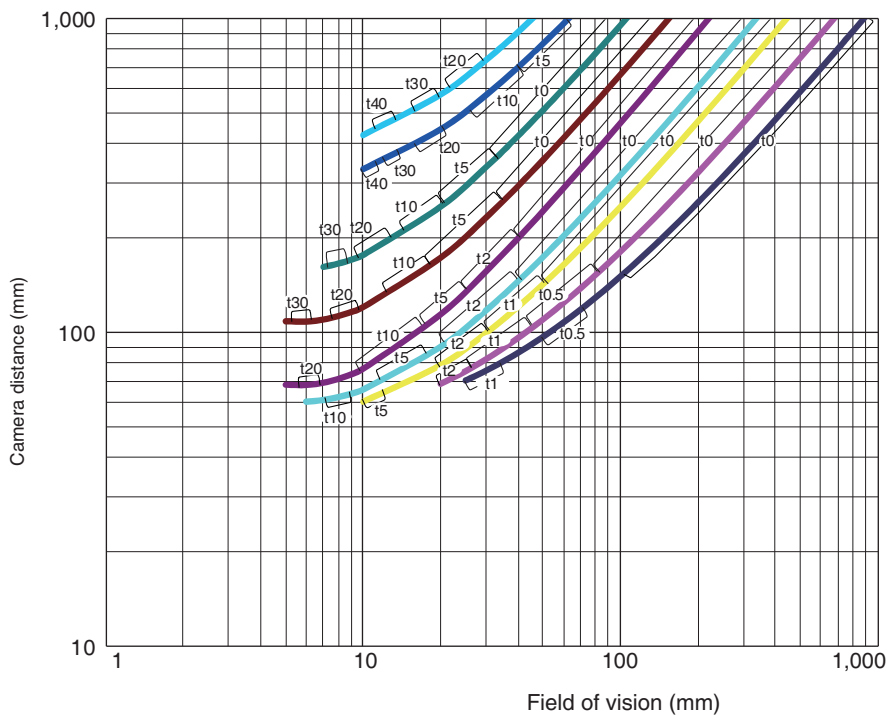

5 million-pixel digital camera FJ-SC5MG2/S5MG2

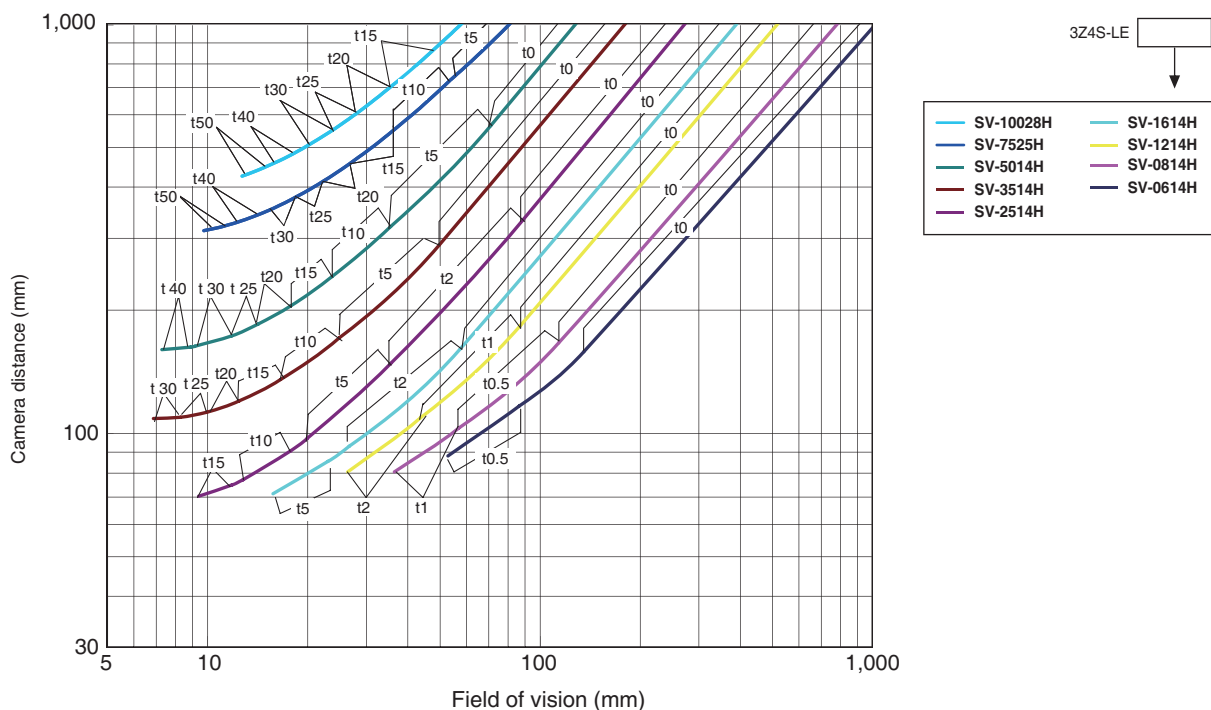

■ Meaning of Optical Chart

The X axis of the optical chart shows the field of vision (mm)(Note1), and the Y axis of the optical chart shows the camera installation distance (mm)(Note2).

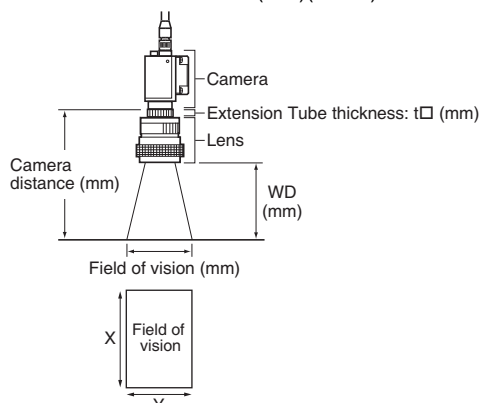

- Note: 1.** The lengths of the fields of vision given in the optical charts are the lengths of the Y axis.
Note: 2. The vertical axis represents WD for small cameras.

Related Manuals/Catalog

Man.No.	Series	Manual
Z428	FJ Series	FJ Series (Camera & Software Vision Package) PC Vision System Camera Setup Guide

- Microsoft® Visual Studio® and Windows are either registered trademarks or trademarks of Microsoft Corporation in the United States and/or other countries.
- Intel and the Intel logo are trademarks of Intel Corporation in the U.S. and/or other countries.
- Other company names and product names in this document are the trademarks or registered trademarks of their respective companies.

Terms and Conditions Agreement

Read and understand this catalog.

Please read and understand this catalog before purchasing the products. Please consult your OMRON representative if you have any questions or comments.

Warranties.

(a) Exclusive Warranty. Omron's exclusive warranty is that the Products will be free from defects in materials and workmanship for a period of twelve months from the date of sale by Omron (or such other period expressed in writing by Omron). Omron disclaims all other warranties, express or implied.

(b) Limitations. OMRON MAKES NO WARRANTY OR REPRESENTATION, EXPRESS OR IMPLIED, ABOUT NON-INFRINGEMENT, MERCHANTABILITY OR FITNESS FOR A PARTICULAR PURPOSE OF THE PRODUCTS. BUYER ACKNOWLEDGES THAT IT ALONE HAS DETERMINED THAT THE PRODUCTS WILL SUITABLY MEET THE REQUIREMENTS OF THEIR INTENDED USE.

Omron further disclaims all warranties and responsibility of any type for claims or expenses based on infringement by the Products or otherwise of any intellectual property right. (c) Buyer Remedy. Omron's sole obligation hereunder shall be, at Omron's election, to (i) replace (in the form originally shipped with Buyer responsible for labor charges for removal or replacement thereof) the non-complying Product, (ii) repair the non-complying Product, or (iii) repay or credit Buyer an amount equal to the purchase price of the non-complying Product; provided that in no event shall Omron be responsible for warranty, repair, indemnity or any other claims or expenses regarding the Products unless Omron's analysis confirms that the Products were properly handled, stored, installed and maintained and not subject to contamination, abuse, misuse or inappropriate modification. Return of any Products by Buyer must be approved in writing by Omron before shipment. Omron Companies shall not be liable for the suitability or unsuitability or the results from the use of Products in combination with any electrical or electronic components, circuits, system assemblies or any other materials or substances or environments. Any advice, recommendations or information given orally or in writing, are not to be construed as an amendment or addition to the above warranty.

See <http://www.omron.com/global/> or contact your Omron representative for published information.

Limitation on Liability; Etc.

OMRON COMPANIES SHALL NOT BE LIABLE FOR SPECIAL, INDIRECT, INCIDENTAL, OR CONSEQUENTIAL DAMAGES, LOSS OF PROFITS OR PRODUCTION OR COMMERCIAL LOSS IN ANY WAY CONNECTED WITH THE PRODUCTS, WHETHER SUCH CLAIM IS BASED IN CONTRACT, WARRANTY, NEGLIGENCE OR STRICT LIABILITY.

Further, in no event shall liability of Omron Companies exceed the individual price of the Product on which liability is asserted.

Suitability of Use.

Omron Companies shall not be responsible for conformity with any standards, codes or regulations which apply to the combination of the Product in the Buyer's application or use of the Product. At Buyer's request, Omron will provide applicable third party certification documents identifying ratings and limitations of use which apply to the Product. This information by itself is not sufficient for a complete determination of the suitability of the Product in combination with the end product, machine, system, or other application or use. Buyer shall be solely responsible for determining appropriateness of the particular Product with respect to Buyer's application, product or system. Buyer shall take application responsibility in all cases.

NEVER USE THE PRODUCT FOR AN APPLICATION INVOLVING SERIOUS RISK TO LIFE OR PROPERTY OR IN LARGE QUANTITIES WITHOUT ENSURING THAT THE SYSTEM AS A WHOLE HAS BEEN DESIGNED TO ADDRESS THE RISKS, AND THAT THE OMRON PRODUCT(S) IS PROPERLY RATED AND INSTALLED FOR THE INTENDED USE WITHIN THE OVERALL EQUIPMENT OR SYSTEM.

Programmable Products.

Omron Companies shall not be responsible for the user's programming of a programmable Product, or any consequence thereof.

Performance Data.

Data presented in Omron Company websites, catalogs and other materials is provided as a guide for the user in determining suitability and does not constitute a warranty. It may represent the result of Omron's test conditions, and the user must correlate it to actual application requirements. Actual performance is subject to the Omron's Warranty and Limitations of Liability.

Change in Specifications.

Product specifications and accessories may be changed at any time based on improvements and other reasons. It is our practice to change part numbers when published ratings or features are changed, or when significant construction changes are made. However, some specifications of the Product may be changed without any notice. When in doubt, special part numbers may be assigned to fix or establish key specifications for your application. Please consult with your Omron's representative at any time to confirm actual specifications of purchased Product.

Errors and Omissions.

Information presented by Omron Companies has been checked and is believed to be accurate; however, no responsibility is assumed for clerical, typographical or proofreading errors or omissions.

Note: Do not use this document to operate the Unit.

OMRON Corporation Industrial Automation Company

Kyoto, JAPAN

Contact: www.ia.omron.com

Regional Headquarters

OMRON EUROPE B.V.

Wegalaan 67-69, 2132 JD Hoofddorp
The Netherlands

Tel: (31)2356-81-300/Fax: (31)2356-81-388

OMRON ELECTRONICS LLC

2895 Greenspoint Parkway, Suite 200
Hoffman Estates, IL 60169 U.S.A.

Tel: (1) 847-843-7900/Fax: (1) 847-843-7787

OMRON ASIA PACIFIC PTE. LTD.

No. 438A Alexandra Road # 05-05/08 (Lobby 2),
Alexandra Technopark,
Singapore 119967

Tel: (65) 6835-3011/Fax: (65) 6835-2711

OMRON (CHINA) CO., LTD.

Room 2211, Bank of China Tower,
200 Yin Cheng Zhong Road,
PuDong New Area, Shanghai, 200120, China

Tel: (86) 21-5037-2222/Fax: (86) 21-5037-2200

Authorized Distributor:

© OMRON Corporation 2011-2020 All Rights Reserved.
In the interest of product improvement,
specifications are subject to change without notice.

CSM_4_3

Cat. No. Q188-E1-04

1220(0811)

X-ON Electronics

Largest Supplier of Electrical and Electronic Components

Click to view similar products for [DC Power Cords](#) category:

Click to view products by [Omron](#) manufacturer:

Other Similar products are found below :

[172-4000](#) [172-4101](#) [172-7443-E](#) [21033836407](#) [2J-1865A](#) [2R7006A20A120](#) [426055400-3](#) [MN47A4BC01M010](#) [H-OU-2](#) [CA0002](#)
[420680840-3](#) [426451500-3](#) [P162PT4-36](#) [1-832692-4](#) [FJ-VSP 3M](#) [96CB-POWER-B-1.8M2](#) [426040200](#) [CA0006](#) [H-OU-27](#) [1700019464](#) [FJ-](#)
[VSP 10M](#) [MN47B4BC01M040](#) [H-OU-20](#) [2-836917-8](#) [867566-1](#) [804001P03M050G](#) [2050KH1-BK](#) [426013710-3](#) [58257-1069](#) [216603-0037](#)
[1011147](#) [1011324](#) [1012028](#) [862545-5](#) [BXC-10567](#) [172-2555](#) [32102-022800-200-RS](#) [P29000-M2](#) [P29004-M2](#) [DC.CAB.0201.0150](#)
[DC.CAB.0301.0150](#) [DC.CAB.0610.0150](#) [DC.CAB.0700.0150](#) [DC.CAB.1000.0300](#) [DC.CAB.1100.0150](#) [DC.CAB.1400.0150](#)
[DC.CAB.1410.0150](#) [DC.CAB.1500.0150](#) [DC.CAB.1811.0150](#) [DC.CAB.1900.0150](#)