

A wide range of contact forms and functions
Over 180 different models available

G3VM MOSFET RELAYS

SELECTION GUIDE

What's NEW!

MOS FET Relay Module is now available

Very small packages (VSON(R), S-VSON(L)) are now available

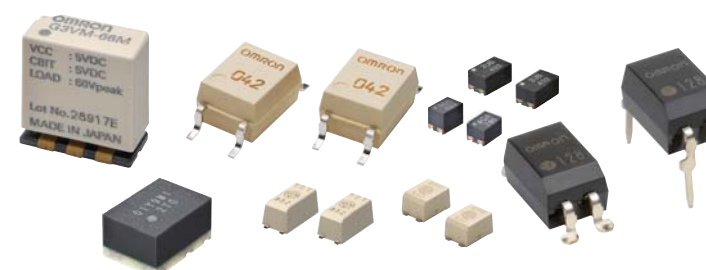

G3VM

MOS FET Relays
MOS FET Relay Modules

Please check each region's Terms & Conditions by region website.

OMRON Corporation
Electronic and Mechanical Components Company

Regional Contact

Americas
<https://www.components.omron.com/>
Asia-Pacific
<https://ecb.omron.com.sg/>
Korea
<https://www.omron-ecb.co.kr/>

Europe
<http://components.omron.eu/>
China
<https://www.ecb.omron.com.cn/>
Japan
<https://www.omron.co.jp/ecb/>

MOS FET Relay Module SPDT contact form type line up

The new value of MOS FET Relays now available

MOS FET Relay Modules are new products which bring SPDT contact structure, while still keeping long endurance and high reliability. These modules are suitable for many applications that use SPDT mechanical relays in place of reed relays, as they eliminate endurance concerns.

MOS FET Relay Module SPDT contact form type



NEW

G3VM-26M10 (Low C_{OFF})

Suitable for high-frequency switching (≤300MHz)

G3VM-26M11 (Low R_{ON})

Suitable for high-current switching (≤1A)

G3VM-66M (Diversified)

Can be used for various purposes due to 60V 0.4A rating

Feature 1 Easily achieve SPDT contact structure on your board

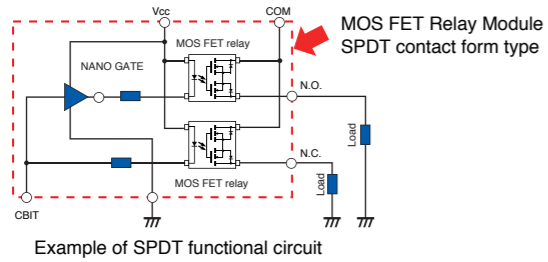

Complex wiring/components choices not needed

Whole complex circuit in module
SPDT module contributes to efficiency of board design.

Feature 2 Saves mounting area due to vertical structure

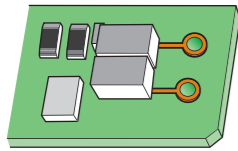

If making them on board ... 250 mm² *



Mounting Space ... 56 mm²

Compared with making them on board

78%* area saving

Contributes to space efficiency and better performance for your equipment.

* By our own research

Feature 3 Contributes to long life

Wear failure will no happen due to switching, because no physical contacts exist inside.

Product family of SPDT Modules

SPDT Modules											
Load Voltage (V) Max.	Model	Number of terminals	Contact form	Continuous load current (mA) Max.	Maximum resistance with output ON (Ohm) Typ.	Current leakage when the relay is open (nA) Max.	Capacitance between terminals (pF) Typ.	Turn-ON time (ms) Max.	Turn-OFF time (ms) Max.	Rated input voltage (V)	Dielectric strength between I/O (Vrms)
20	G3VM-26M10	6	SPDT	200	4.4	2	1	0.3	0.3	5	500
20	G3VM-26M11	6	SPDT	1000	0.21	2	40	2.5	1.5	5	500
60	G3VM-66M	6	SPDT	400	1	2	20	1	1	5	500

Dimensions

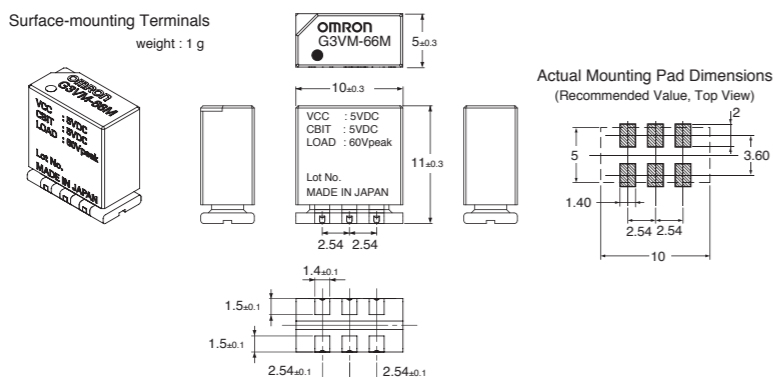

MOS FET Relay Module T switch function type line up

The world's first * very low leakage current MOS FET Relay modules by "T-structure inside".

These modules achieve very low leakage current which contribute high accuracy measurement of testing equipment for semiconductors and so on. It's the world's first* "T structure circuit installed" module with a combined 3 MOS FET relays.

*As of 2019, April.

MOS FET Relay Module T switch function type



NEW

G3VM-21MT (Low C_{xR})

Suitable for High frequency (≤1.5GHz) and low signal

* Developing other line up now

Feature 1 Achieves extremely low leakage current

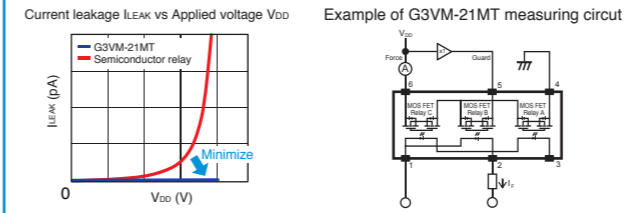

Leakage current ≤1pA

Actual performance is lower than 0.1pA for lowest suppressing effect for accuracy of measurement equipment. This is suitable for as an alternative from Reed relays.

Feature 2 Contributes to mounting area saving due to a very small package

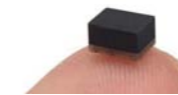

Very small outline

5 mm × 3.75 mm × 2.7 mm

Achieves very small size even though it's equipped with complex circuits. Contributes to high density mounting on the board.

Feature 3 Significant reduction for maintenance cycles

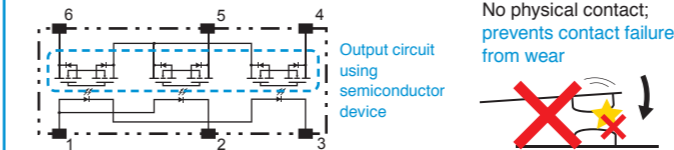

Very long life

Output circuit is structured by MOS FET relay, which is a semiconductor with no physical contact. Therefore, there is no wear failure due to no switching of arc.

T Module Structure Product Line Up

T structure Modules										
Load Voltage (V) Max.	Model	Number of terminals	Contact form	Continuous load current (mA) Max.	Maximum resistance with output ON (Ohm) Typ.	Current leakage when the relay is open (pA) Max.	Capacitance between terminals (pF) Typ.	Turn-ON time (ms) Max.	Turn-OFF time (ms) Max.	Dielectric strength between I/O (Vrms)
20	G3VM-21MT NEW	6	1a*	200	8	1	0.6	0.3	0.3	500

* Please see Operation mode on datasheet for detail

Dimensions

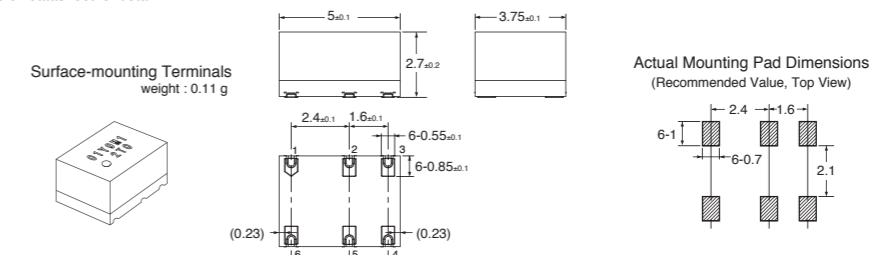

MOS FET Relay Modules model number legend

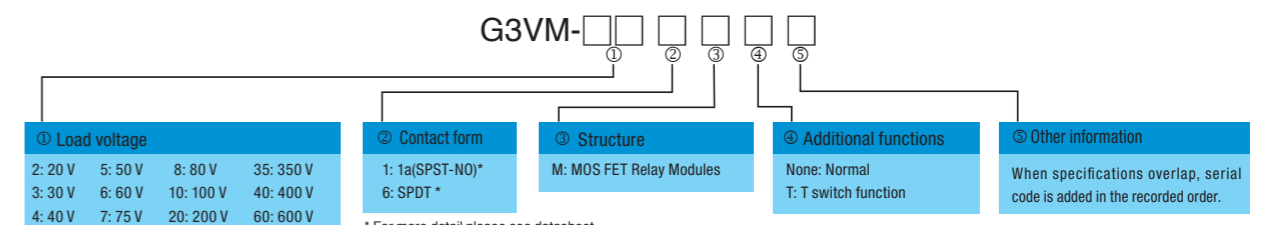

* For more detail please see datasheet

MOS FET Relay Module SPDT contact form type line up

The new value of MOS FET Relays now available

MOS FET Relay Modules are new products which bring SPDT contact structure, while still keeping long endurance and high reliability. These modules are suitable for many applications that use SPDT mechanical relays in place of reed relays, as they eliminate endurance concerns.

MOS FET Relay Module SPDT contact form type



NEW

G3VM-26M10 (Low C_{OFF})

Suitable for high-frequency switching (≤300MHz)

G3VM-26M11 (Low R_{ON})

Suitable for high-current switching (≤1A)

G3VM-66M (Diversified)

Can be used for various purposes due to 60V 0.4A rating

Feature 1 Easily achieve SPDT contact structure on your board

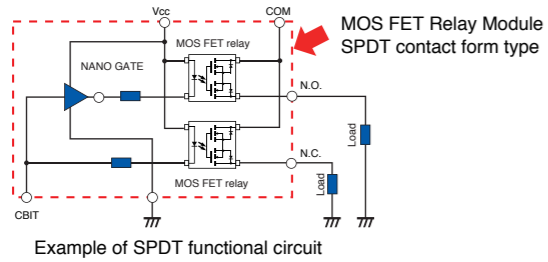

Complex wiring/components choices not needed

Whole complex circuit in module
SPDT module contributes to efficiency of board design.

Feature 2 Saves mounting area due to vertical structure

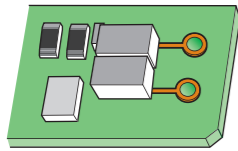

If making them on board ... 250 mm² *



Mounting Space ... 56 mm²

Compared with making them on board

78%* area saving

Contributes to space efficiency and better performance for your equipment.

* By our own research

Feature 3 Contributes to long life

Wear failure will no happen due to switching, because no physical contacts exist inside.

Product family of SPDT Modules

SPDT Modules											
Load Voltage (V) Max.	Model	Number of terminals	Contact form	Continuous load current (mA) Max.	Maximum resistance with output ON (Ohm) Typ.	Current leakage when the relay is open (nA) Max.	Capacitance between terminals (pF) Typ.	Turn-ON time (ms) Max.	Turn-OFF time (ms) Max.	Rated input voltage (V)	Dielectric strength between I/O (Vrms)
20	G3VM-26M10	6	SPDT	200	4.4	2	1	0.3	0.3	5	500
20	G3VM-26M11	6	SPDT	1000	0.21	2	40	2.5	1.5	5	500
60	G3VM-66M	6	SPDT	400	1	2	20	1	1	5	500

Dimensions

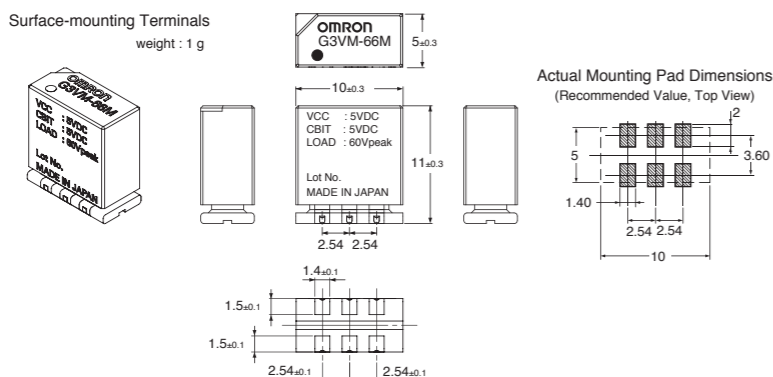

MOS FET Relay Module T switch function type line up

The world's first * very low leakage current MOS FET Relay modules by "T-structure inside".

These modules achieve very low leakage current which contribute high accuracy measurement of testing equipment for semiconductors and so on. It's the world's first* "T structure circuit installed" module with a combined 3 MOS FET relays.

*As of 2019, April.

MOS FET Relay Module T switch function type



NEW

G3VM-21MT (Low C_{xR})

Suitable for High frequency (≤1.5GHz) and low signal

* Developing other line up now

Feature 1 Achieves extremely low leakage current

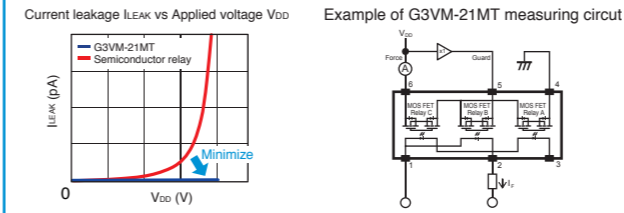

Leakage current ≤1pA

Actual performance is lower than 0.1pA for lowest suppressing effect for accuracy of measurement equipment. This is suitable for as an alternative from Reed relays.

Feature 2 Contributes to mounting area saving due to a very small package

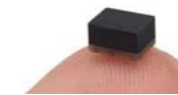

Very small outline

5 mm × 3.75 mm × 2.7 mm

Achieves very small size even though it's equipped with complex circuits. Contributes to high density mounting on the board.

Feature 3 Significant reduction for maintenance cycles

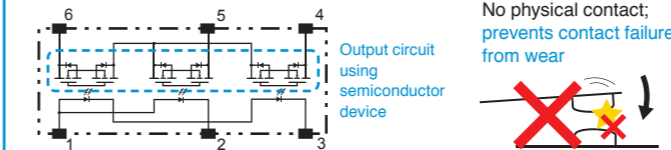

Very long life

Output circuit is structured by MOS FET relay, which is a semiconductor with no physical contact. Therefore, there is no wear failure due to no switching of arc.

T Module Structure Product Line Up

T structure Modules											
Load Voltage (V) Max.	Model	Number of terminals	Contact form	Continuous load current (mA) Max.	Maximum resistance with output ON (Ohm) Typ.	Current leakage when the relay is open (pA) Max.	Capacitance between terminals (pF) Typ.	Turn-ON time (ms) Max.	Turn-OFF time (ms) Max.	Dielectric strength between I/O (Vrms)	
20	G3VM-21MT NEW	6	1a*	200	8	1	0.6	0.3	0.3	500	

* Please see Operation mode on datasheet for detail

Dimensions

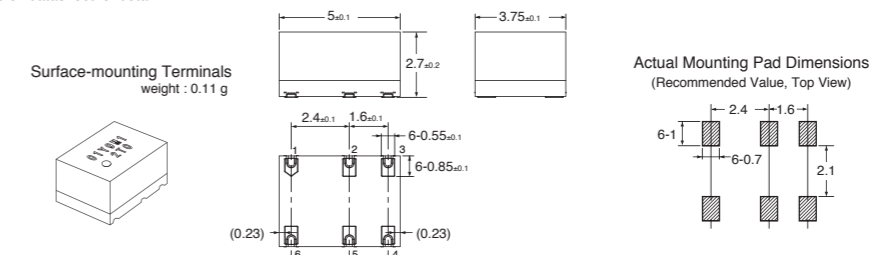

MOS FET Relay Modules model number legend

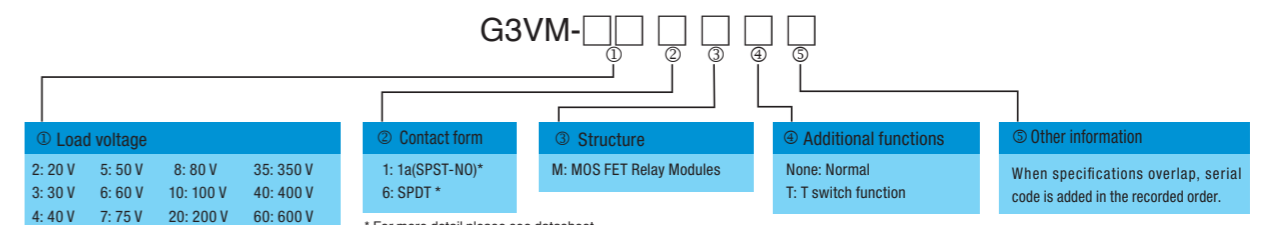

* For more detail please see datasheet

About MOS FET relays

OMRON's MOS FET Relays lead the industry in optical semiconductor technology, utilizing an input LED, Photodiode Dome Array (PDA) used as photocoupler and MOS FET chip in the load switching current.

In addition to being maintenance free, the MOS FET relay features high-speed operation and compact size, further promoting the replacement of mechanical relays.

Omron is expanding its wide range of products, from the industry's smallest class* new package (S-VSON/VSON) to our high current, high dielectric strength, and high sensitivity models.

*As of March, 2018.

Advantages of MOS FET relays

Ultra small size and weight

In addition to small size and weight the ultra-compact VSON and S-VSON packages, contributing to downsizing of equipment.

Low drive currents

Realizing energy saving with standard driving current of 2-15mA. Ultrasensitive models are also available featuring Drive Currents as low as 0.2mA (max).

Long operating life

MOS FET Relays use light signal instead of moveable contacts, avoiding reduction of life caused by contact wear, substantially increasing operational life.

Small leakage current

Can withstand external surge current without addition of snubber circuit. Under normal conditions, the typical leakage current is about 1 nA or below.

Excellent shock resistance

All the internal parts use casting method, and there are no movable parts in it, so it has excellent shock and vibration resistance.

High insulation

MOS FET relays offer great I/O isolation due to their operational principles. They turn the voltage into light and transfer by light signal, therefore input and output are isolated. The standard models offer 2,500 Vrms between input and output. Superior 5,000 VAC products are also available. 3,750 VAC products have also been added to the SOP package series.

Silent operation

As MOS FET Relays do not have mechanical contacts, by using a MOS FET instead of an electromechanical relay, it is possible to eliminate switching noise in your applications.

High-speed switching

Comparing with the switching time of 3 to 5 ms of a mechanical relay, its switching time is shortened to 0.2 ms(SSOP, USOP, VSON). It achieves quick response performance.

Control the micro analog signal correctly

Comparing with the triac, MOS FET greatly reduces the dead zone. The input waveform of micro analog signal does not suffer distortion as it does with a triac and is basically converted into output waveform without distortion.

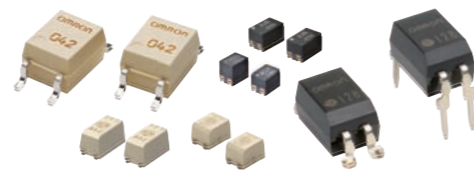

Structure and operational principle of MOS FET relays

[Internal structure]

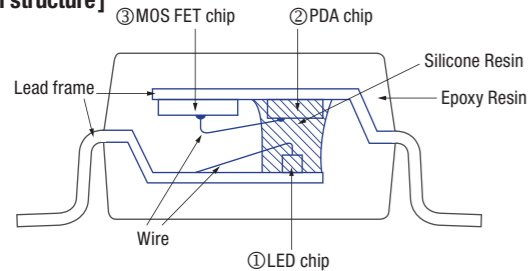

MOS FET relay consists of the following three components:

- ① LED (light emitting diode)
- ② Photodiode dome array (PDA)
- ③ MOS FET

[Operational Principle]

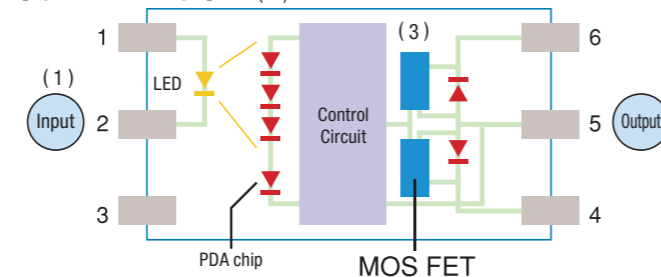

- (1) The LED lights up when the current is connected at the input side.
- (2) The light sent by the LED will be converted into voltage when it is received by the photodiode.
- (3) This voltage will be the gate voltage to drive the MOS FET via control circuit.

Features of OMRON's MOS FET Relays

Feature 1 Achieves high sensitivity (low driving current) with white mold resin package!

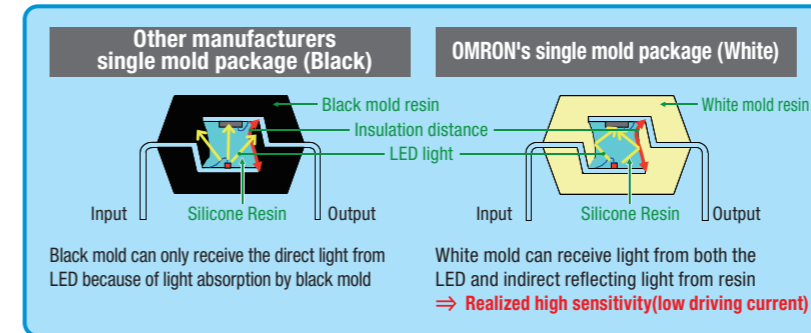

Many models of OMRON's MOS FET Relays are made with white mold resin in order to achieve high sensitivity.

Feature 2 High dielectric strength is achieved with the black package!

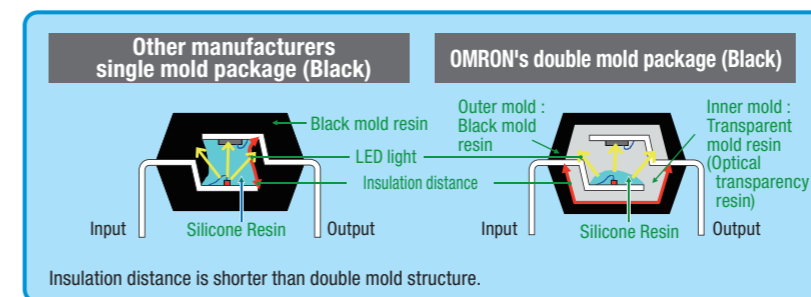

High Dielectric Strength types adopted a black package (black mold resin). And High Dielectric Strength was achieved by the double mold structure. Black package models have been added to the DIP and SOP series. DIP: 5,000 VAC, SOP: 3,750 VAC

Feature 3 Good solderability with small package!

● SSOP/USOP Package ··· Lead type

● VSON/S-VSON Package ··· Non-lead type



3 Selection Tips

Tip 1

Take note of voltage and current values

Load voltage and continuous load current values are the maximum values. Take particular note in the case of AC load.

$$\text{Effective value} \times \sqrt{2} = \text{maximum value}$$

Ex. Commercial power 100 VAC (effective value) -> select from maximum value of 141 V or above

Tip 2

Load with inrush current

Guide for inrush current:
up to 3x the continuous load current (100 ms)
(Listed in the catalog as "Pulse ON current")

Tip 3

Double the current volume with connection C (DC load only)

Types compatible with connection C (parallel connection of two MOS FET elements) offer switching with double the continuous load current.

DIP/SOP 6-pin package

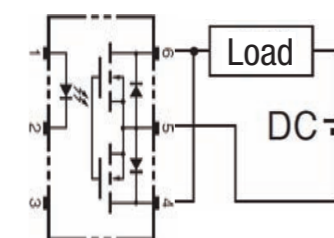

DIP 8-pin package (for CR□/FR□ types only)

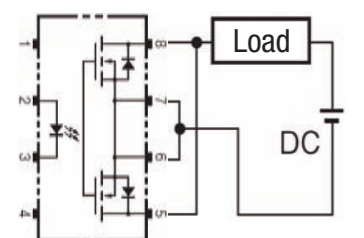

About MOS FET relays

OMRON's MOS FET Relays lead the industry in optical semiconductor technology, utilizing an input LED, Photodiode Dome Array (PDA) used as photocoupler and MOS FET chip in the load switching current.

In addition to being maintenance free, the MOS FET relay features high-speed operation and compact size, further promoting the replacement of mechanical relays.

Omron is expanding its wide range of products, from the industry's smallest class* new package (S-VSON/VSON) to our high current, high dielectric strength, and high sensitivity models.

*As of March, 2018.

Advantages of MOS FET relays

Ultra small size and weight

In addition to small size and weight the ultra-compact VSON and S-VSON packages, contributing to downsizing of equipment.

Low drive currents

Realizing energy saving with standard driving current of 2-15mA. Ultrasensitive models are also available featuring Drive Currents as low as 0.2mA (max).

Long operating life

MOS FET Relays use light signal instead of moveable contacts, avoiding reduction of life caused by contact wear, substantially increasing operational life.

Small leakage current

Can withstand external surge current without addition of snubber circuit. Under normal conditions, the typical leakage current is about 1 nA or below.

Excellent shock resistance

All the internal parts use casting method, and there are no movable parts in it, so it has excellent shock and vibration resistance.

High insulation

MOS FET relays offer great I/O isolation due to their operational principles. They turn the voltage into light and transfer by light signal, therefore input and output are isolated. The standard models offer 2,500 Vrms between input and output. Superior 5,000 VAC products are also available. 3,750 VAC products have also been added to the SOP package series.

Silent operation

As MOS FET Relays do not have mechanical contacts, by using a MOS FET instead of an electromechanical relay, it is possible to eliminate switching noise in your applications.

High-speed switching

Comparing with the switching time of 3 to 5 ms of a mechanical relay, its switching time is shortened to 0.2 ms(SSOP, USOP, VSON). It achieves quick response performance.

Control the micro analog signal correctly

Comparing with the triac, MOS FET greatly reduces the dead zone. The input waveform of micro analog signal does not suffer distortion as it does with a triac and is basically converted into output waveform without distortion.

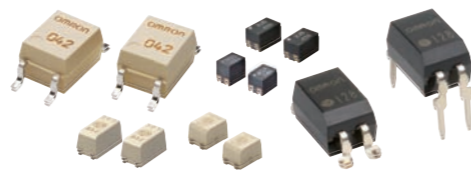

Structure and operational principle of MOS FET relays

[Internal structure]

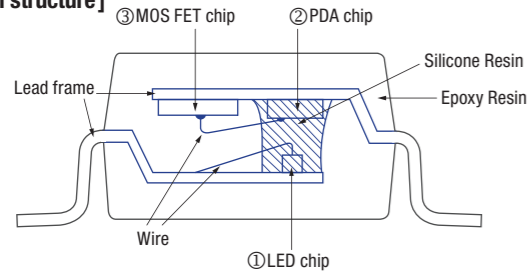

MOS FET relay consists of the following three components:

- ① LED (light emitting diode)
- ② Photodiode dome array (PDA)
- ③ MOS FET

[Operational Principle]

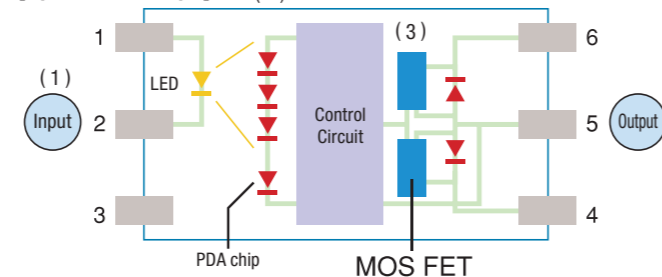

- (1) The LED lights up when the current is connected at the input side.
- (2) The light sent by the LED will be converted into voltage when it is received by the photodiode.
- (3) This voltage will be the gate voltage to drive the MOS FET via control circuit.

Features of OMRON's MOS FET Relays

Feature 1 Achieves high sensitivity (low driving current) with white mold resin package!

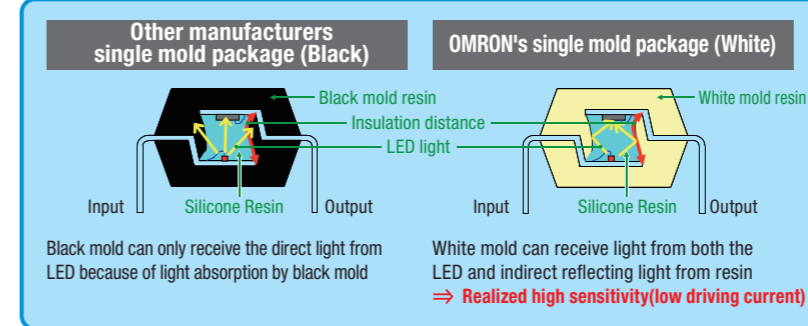

Many models of OMRON's MOS FET Relays are made with white mold resin in order to achieve high sensitivity.

Feature 2 High dielectric strength is achieved with the black package!

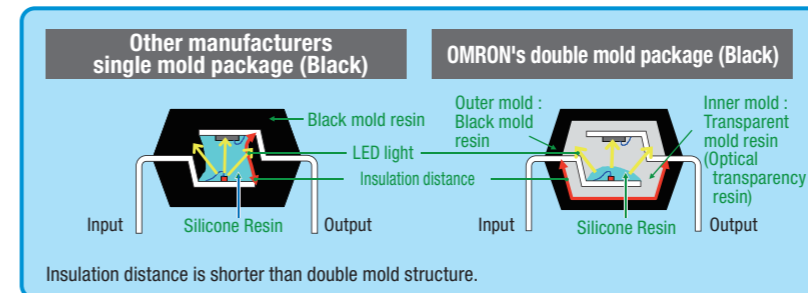

High Dielectric Strength types adopted a black package (black mold resin). And High Dielectric Strength was achieved by the double mold structure. Black package models have been added to the DIP and SOP series. DIP: 5,000 VAC, SOP: 3,750 VAC

Feature 3 Good solderability with small package!

● SSOP/USOP Package ··· Lead type

● VSON/S-VSON Package ··· Non-lead type



3 Selection Tips

Tip 1

Take note of voltage and current values

Load voltage and continuous load current values are the maximum values. Take particular note in the case of AC load.

$$\text{Effective value} \times \sqrt{2} = \text{maximum value}$$

Ex. Commercial power 100 VAC (effective value) -> select from maximum value of 141 V or above

Tip 2

Load with inrush current

Guide for inrush current:
up to 3x the continuous load current (100 ms)
(Listed in the catalog as "Pulse ON current")

Tip 3

Double the current volume with connection C (DC load only)

Types compatible with connection C (parallel connection of two MOS FET elements) offer switching with double the continuous load current.

DIP/SOP 6-pin package

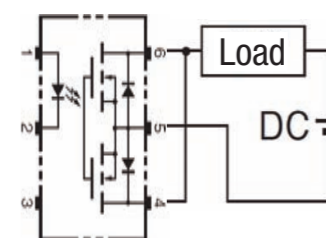

DIP 8-pin package (for CR□/FR□ types only)

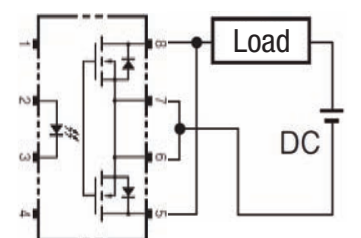

MOS FET Relay Lineup

Package of MOS FET Relays

DIP

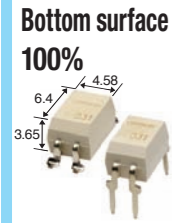

SOP

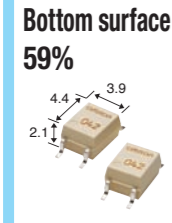

SSOP

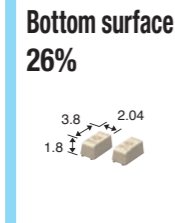

USOP

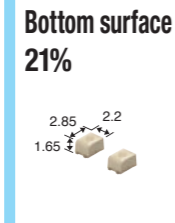

VSON(R)

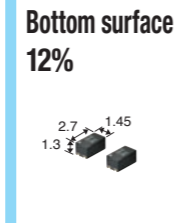

VSON

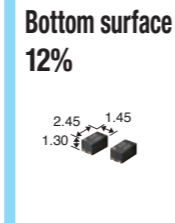

S-VSON

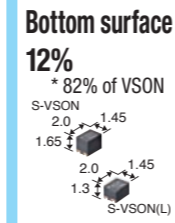

General Purpose Type



Best-selling products suitable for various applications. Ideal for AC/DC load, Micro analog signal.

Package	Model	Contact form	Load voltage (V) Max.	Continuous load current (mA) Max.	Dielectric strength between I/O (Vrms)
DIP	G3VM-61A1/D1	1a	60	500	2500
	G3VM-61B1/E1	1a	60	500 (1000) ¹⁾	2500
	G3VM-62C1/F1	2a	60	500	2500
	G3VM-351A/D	1a	350	120	2500
	G3VM-352C/F	2a	350	120	2500
SOP	G3VM-61VY2 ²⁾	1a	60	500	3750
	G3VM-61VY3 ²⁾ NEW	1a	60	700	3750
	G3VM-63G	1b	60	500	1500
	G3VM-61H1	1a	60	400 (800) ¹⁾	1500
	G3VM-62J1	2a	60	400	1500
	G3VM-81G1	1a	80	350	1500
	G3VM-351VY ²⁾	1a	350	110	3750
	G3VM-353G	1b	350	120	1500
	G3VM-351H	1a	350	110 (220) ¹⁾	1500
	G3VM-352J	2a	350	110	1500
	G3VM-401G	1a	400	120	1500

¹⁾ Load current in case of connection C is shown in parentheses (DC load only)
²⁾ VY2 and VY3 types: Special SOP4 pin package

High Current & Low On-resistance Type



Offers High Current & Low On-resistance in the same level as the mechanical relay.

Package	Model	Load voltage (V) Max.	Continuous load current (A) Max.	Maximum resistance with output ON(Ω) Typ.
DIP	G3VM-31AR/DR NEW	30	4	0.025
	G3VM-31BR/ER NEW	30	5 (10) ¹⁾	0.02 (0.005) ¹⁾
	G3VM-61AR1/DR1 NEW	60	3	0.045
	G3VM-61BR2/ER2 NEW	60	4 (8) ¹⁾	0.035 (0.013) ¹⁾
	G3VM-101AR1/DR1 NEW	100	2	0.11
	G3VM-101BR1/ER1 NEW	100	3.5 (7) ¹⁾	0.05 (0.012) ¹⁾
	G3VM-201AR/DR NEW	200	0.7	0.09
	G3VM-31HR1 NEW	30	4.5 (9) ¹⁾	0.022 (0.006) ¹⁾
SOP	G3VM-61VR ²⁾ NEW	60	1.4	0.13
	G3VM-61GR2	60	1.7	0.08
	G3VM-61HR2 NEW	60	4 (8) ¹⁾	0.028 (0.04) ¹⁾
	G3VM-101HR2 NEW	100	3 (6) ¹⁾	0.05 (0.013) ¹⁾
S-VSON	G3VM-31QR NEW	30	1.5	0.1
	G3VM-61QR2 NEW	60	1	0.2
	G3VM-101QR1 NEW	100	0.65	0.4

¹⁾ Load current in case of connection C is shown in parentheses (DC load only)
²⁾ 61VR type: Special SOP4 pin package

MOS FET Relay Lineup

Ultrasensitive Type



Ideal for energy saving, various battery-driven devices. Ultrasensitive Driving current* 0.2 mA (Max.) with SOP4 available.

*Driving current = LED forward current

■ SOP package

Model	Load voltage (V) Max.	Continuous load current (mA) Max.	Trigger LED forward current (mA) Max.	Recommended Trigger LED forward current (mA) Max.
G3VM-61G2	60	400	1	2
G3VM-61G3	60	400	0.2	0.5
G3VM-201G1	200	200	1	2
G3VM-201G2	200	200	0.2	0.5
G3VM-351G1	350	100	1	2
G3VM-401G1	400	100	0.2	0.5
G3VM-601G1	600	70	0.2	0.5
G3VM-601G	600	90	1	2

Voltage Driven Type



Can be used by voltage control due to LED current limiting register inside. Contribute simply surrounding circuit and reducing part number on board.

■ VSON (R) package

Model	Load voltage (V) Max.	Continuous load current (A) Max.	Capacitance between terminals (pF) Typ.	Recommended Operating voltage (V) Typ.
G3VM-21UV11 NEW	20	1	40	5
G3VM-51UV NEW	50	0.3	12	5
G3VM-61UV NEW	60	0.4	20	5

■ S-VSON (L) package

Model	Load voltage (V) Max.	Continuous load current (A) Max.	Capacitance between terminals (pF) Typ.	Recommended Operating voltage (V) Typ.
G3VM-31QVH NEW	30	1.5	120	5
G3VM-31QVL NEW	30	1.5	120	2.5
G3VM-61QV2H NEW	60	1	80	5
G3VM-61QV2L NEW	60	1	80	2.5
G3VM-61QVH NEW	60	0.4	20 Max.	5

Low Output Capacitance and ON Resistance Type (Low CxR)

Ideal for semi-conductor test equipment. low C(capacitance between terminals) × R(output on-resistance) type.



■ USOP package

Model	Load voltage (V) Max.	Continuous load current (mA) Max.	Maximum resistance with output ON(Ω) Typ.	Capacitance between terminals (pF) Typ.
G3VM-21PR1	20	450	0.6	5
G3VM-21PR10	20	200	3	0.8
G3VM-21PR11	20	900	0.18	40
G3VM-41PR12	40	100	15	0.3
G3VM-41PR6	40	120	10	1
G3VM-41PR10	40	120	12	0.45
G3VM-41PR11	40	140	7	0.7
G3VM-61PR1	60	120	10	0.7

■ VSON package

Model	Load voltage (V) Max.	Continuous load current (mA) Max.	Maximum resistance with output ON(Ω) Typ.	Capacitance between terminals (pF) Typ.
G3VM-21UR10	20	200	3	0.8
G3VM-21UR1	20	450	0.8	5
G3VM-21UR11	20	1000	0.18	40
G3VM-41UR12	40	100	15	0.3
G3VM-41UR10	40	120	12	0.45
G3VM-41UR11	40	140	7	0.7
G3VM-61UR1	60	120	10	0.7

■ S-VSON package

Model	Load voltage (V) Max.	Continuous load current (mA) Max.	Maximum resistance with output ON(Ω) Typ.	Capacitance between terminals (pF) Typ.
G3VM-41QR10* NEW	40	120	11	0.45
G3VM-61QR NEW	60	400	1.1	12

* 41QR10 type: S-VSON(L)package (Low profile type)

G3VM Model Number Legend

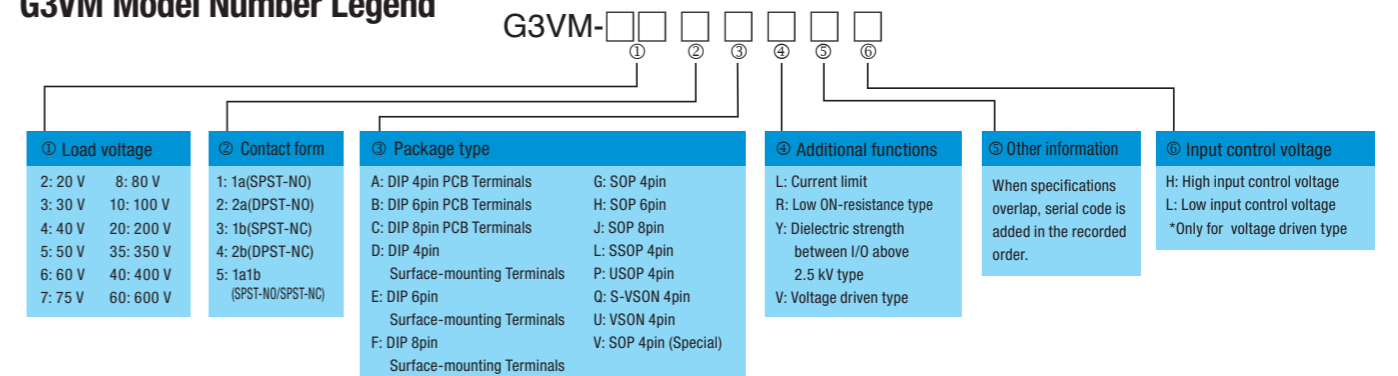

Note 1 : Some products may have a different model number structure. Note 2 : In order to avoid the confusion of I (English letter) and 1 (number), I (English letter) is not used here. Note 3 : For 4-pin SOP models, where the available marking space is insufficient to clearly differentiate model numbers with 6 or more suffix digits, the package type code ③ is omitted.

MOS FET Relay Lineup

Package of MOS FET Relays

DIP Bottom surface 100% 	SOP Bottom surface 59% 	SSOP Bottom surface 26% 	USOP Bottom surface 21% 	VSON(R) Bottom surface 12% 	VSON Bottom surface 12% 	S-VSON Bottom surface 12% * 82% of VSON
---	--	---	---	--	---	--

General Purpose Type



Best-selling products suitable for various applications.
Ideal for AC/DC load, Micro analog signal.

Package	Model	Contact form	Load voltage (V) Max.	Continuous load current (mA) Max.	Dielectric strength between I/O (Vrms)
DIP	G3VM-61A1/D1	1a	60	500	2500
	G3VM-61B1/E1	1a	60	500 (1000) ¹⁾	2500
	G3VM-62C1/F1	2a	60	500	2500
	G3VM-351A/D	1a	350	120	2500
	G3VM-352C/F	2a	350	120	2500
SOP	G3VM-61VY2 ²⁾	1a	60	500	3750
	G3VM-61VY3 ²⁾ NEW	1a	60	700	3750
	G3VM-63G	1b	60	500	1500
	G3VM-61H1	1a	60	400 (800) ¹⁾	1500
	G3VM-62J1	2a	60	400	1500
	G3VM-81G1	1a	80	350	1500
	G3VM-351VY ²⁾	1a	350	110	3750
	G3VM-353G	1b	350	120	1500
	G3VM-351H	1a	350	110 (220) ¹⁾	1500
	G3VM-352J	2a	350	110	1500
	G3VM-401G	1a	400	120	1500

¹⁾ Load current in case of connection C is shown in parentheses (DC load only)
²⁾ VY2 and VY3 types: Special SOP4 pin package

High Current & Low On-resistance Type



Offers High Current & Low On-resistance in the same level as the mechanical relay.

Package	Model	Load voltage (V) Max.	Continuous load current (A) Max.	Maximum resistance with output ON(Ω) Typ.	
DIP	G3VM-31AR/DR NEW	30	4	0.025	
	G3VM-31BR/ER NEW	30	5 (10) ¹⁾	0.02 (0.005) ¹⁾	
	G3VM-61AR1/DR1 NEW	60	3	0.045	
	G3VM-61BR2/ER2 NEW	60	4 (8) ¹⁾	0.035 (0.013) ¹⁾	
	G3VM-101AR1/DR1 NEW	100	2	0.11	
	G3VM-101BR1/ER1 NEW	100	3.5 (7) ¹⁾	0.05 (0.012) ¹⁾	
	G3VM-201AR/DR NEW	200	0.7	0.09	
	SOP	G3VM-31HR1 NEW	30	4.5 (9) ¹⁾	0.022 (0.006) ¹⁾
		G3VM-61VR ²⁾ NEW	60	1.4	0.13
		G3VM-61GR2	60	1.7	0.08
G3VM-61HR2 NEW		60	4 (8) ¹⁾	0.028 (0.04) ¹⁾	
S-VSON	G3VM-101HR2 NEW	100	3 (6) ¹⁾	0.05 (0.013) ¹⁾	
	G3VM-31QR NEW	30	1.5	0.1	
	G3VM-61QR2 NEW	60	1	0.2	
	G3VM-101QR1 NEW	100	0.65	0.4	

¹⁾ Load current in case of connection C is shown in parentheses (DC load only)
²⁾ 61VR type: Special SOP4 pin package

MOS FET Relay Lineup

Ultrasensitive Type



Ideal for energy saving, various battery-driven devices.
Ultrasensitive Driving current* 0.2 mA (Max.)
with SOP4 available.

*Driving current = LED forward current

■ SOP package

Model	Load voltage (V) Max.	Continuous load current (mA) Max.	Trigger LED forward current (mA) Max.	Recommended Trigger LED forward current (mA) Max.
G3VM-61G2	60	400	1	2
G3VM-61G3	60	400	0.2	0.5
G3VM-201G1	200	200	1	2
G3VM-201G2	200	200	0.2	0.5
G3VM-351G1	350	100	1	2
G3VM-401G1	400	100	0.2	0.5
G3VM-601G1	600	70	0.2	0.5
G3VM-601G	600	90	1	2

Voltage Driven Type

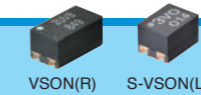

Can be used by voltage control due to LED current limiting register inside.
Contribute simply surrounding circuit and reducing part number on board.

■ VSON (R) package

Model	Load voltage (V) Max.	Continuous load current (A) Max.	Capacitance between terminals (pF) Typ.	Recommended Operating voltage (V) Typ.
G3VM-21UV11 NEW	20	1	40	5
G3VM-51UV NEW	50	0.3	12	5
G3VM-61UV NEW	60	0.4	20	5

■ S-VSON (L) package

Model	Load voltage (V) Max.	Continuous load current (A) Max.	Capacitance between terminals (pF) Typ.	Recommended Operating voltage (V) Typ.
G3VM-31QVH NEW	30	1.5	120	5
G3VM-31QVL NEW	30	1.5	120	2.5
G3VM-61QV2H NEW	60	1	80	5
G3VM-61QV2L NEW	60	1	80	2.5
G3VM-61QVH NEW	60	0.4	20 Max.	5

Low Output Capacitance and ON Resistance Type (Low CxR)

Ideal for semi-conductor test equipment.
low C(capacitance between terminals)
× R(output on-resistance) type.



■ USOP package

Model	Load voltage (V) Max.	Continuous load current (mA) Max.	Maximum resistance with output ON(Ω) Typ.	Capacitance between terminals (pF) Typ.
G3VM-21PR1	20	450	0.6	5
G3VM-21PR10	20	200	3	0.8
G3VM-21PR11	20	900	0.18	40
G3VM-41PR12	40	100	15	0.3
G3VM-41PR6	40	120	10	1
G3VM-41PR10	40	120	12	0.45
G3VM-41PR11	40	140	7	0.7
G3VM-61PR1	60	120	10	0.7

■ VSON package

Model	Load voltage (V) Max.	Continuous load current (mA) Max.	Maximum resistance with output ON(Ω) Typ.	Capacitance between terminals (pF) Typ.
G3VM-21UR10	20	200	3	0.8
G3VM-21UR1	20	450	0.8	5
G3VM-21UR11	20	1000	0.18	40
G3VM-41UR12	40	100	15	0.3
G3VM-41UR10	40	120	12	0.45
G3VM-41UR11	40	140	7	0.7
G3VM-61UR1	60	120	10	0.7

■ S-VSON package

Model	Load voltage (V) Max.	Continuous load current (mA) Max.	Maximum resistance with output ON(Ω) Typ.	Capacitance between terminals (pF) Typ.
G3VM-41QR10* NEW	40	120	11	0.45
G3VM-61QR NEW	60	400	1.1	12

* 41QR10 type: S-VSON(L)package (Low profile type)

G3VM Model Number Legend

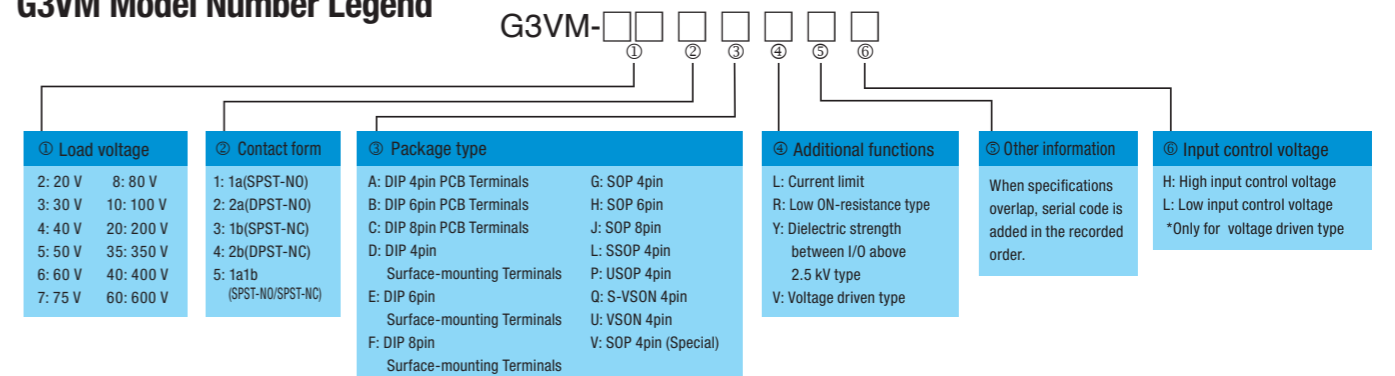

Note 1 : Some products may have a different model number structure. - Note 2 : In order to avoid the confusion of I (English letter) and 1 (number), I (English letter) is not used here.
Note 3 : For 4-pin SOP models, where the available marking space is insufficient to clearly differentiate model numbers with 6 or more suffix digits, the package type code ③ is omitted.

Product lineup of MOS FET Relays

Please refer to our web site or datasheet for more information such as measurement conditions.

DIP (Dual In-line Package)

Load Voltage (V) Max.	Model	Number of terminals	Contact form	Continuous load current (mA) Max.	Maximum resistance with output ON (Ohm) Typ.	Current leakage when the relay is open (nA) Max.	Capacitance between terminals (pF) Typ.	Turn-ON time (ms) Max.	Turn-OFF time (ms) Max.	Dielectric strength between I/O (Vrms)	
20	G3VM-21AR/DR	4	1a	3000	0.04	1000	300	5.0	1.0	2500	
20	G3VM-21BR/ER	6	1a	4000 (8000) ^{*1}	0.02	1000	1000	5.0	1.0	2500	
30	G3VM-31AR/DR	4	1a	4000	0.025	1000	450	3.0	1.0	2500	★
30	G3VM-31BR/ER	6	1a	5000 (8000) ^{*1}	0.02	1000	1100	5.0	0.5	2500	★
40	G3VM-41AY/DY	4	1a	2000	0.09	1000	300	5.0	1.0	5000	
40	G3VM-41AY1/DY1	4	1a	2000	0.09	1000	300	5.0	1.0	5000	
40	G3VM-41AR/DR	4	1a	2500	0.05	1000	300	5.0	1.0	2500	
40	G3VM-41BR/ER	6	1a	3500 (7000) ^{*1}	0.03	1000	1000	5.0	1.0	2500	
60	G3VM-61A1/D1	4	1a	500	1	1000	130	2.0	0.5	2500	
60	G3VM-61AY/DY	4	1a	500	0.6	1000	130	1.0	1.0	5000	
60	G3VM-61AY1/DY1	4	1a	500	0.6	1000	130	3.0	1.0	5000	
60	G3VM-61AR/DR	4	1a	2000	0.08	1000	250	5.0	1.0	2500	
60	G3VM-61AR1/DR1	4	1a	3000	0.045	1000	250	2.0	1.0	2500	★
60	G3VM-61B1/E1	6	1a	500 (1000) ^{*1}	1	1000	130	2.0	0.5	2500	
60	G3VM-61BR/ER	6	1a	2500	0.065	10	400	1.5	0.4	2500	○
60	G3VM-61BR1/ER1	6	1a	3000 (6000) ^{*1}	0.04	1000	1000	5.0	1.0	2500	
60	G3VM-61BR2/ER2	6	1a	4000 (8000) ^{*1}	0.035	1000	640	5.0	0.5	2500	★
60	G3VM-61CR1/FR1	8	1a	5000(10000) ^{*1}	0.022	10000	850	5.0	1.0	2500	
60	G3VM-62C1/F1	8	2a	500	1	1000	130	2.0	0.5	2500	
100	G3VM-101AR/DR	4	1a	1000	0.25	1000	200	5.0	1.0	2500	
100	G3VM-101AR1/DR1	4	1a	2000	0.11	1000	110	2.0	0.5	2500	★
100	G3VM-101BR/ER	6	1a	2000 (4000) ^{*1}	0.1	1000	1000	5.0	1.0	2500	
100	G3VM-101BR1/ER1	6	1a	3500 (7000) ^{*1}	0.05	1000	450	5.0	0.5	2500	★
100	G3VM-101CR/FR	8	1a	3000 (6000) ^{*1}	0.06	1000	720	5.0	1.0	2500	
200	G3VM-201AY/DY	4	1a	250	5	1000	90	1.0	1.0	5000	
200	G3VM-201AY1/DY1	4	1a	250	5	1000	90	3.0	1.0	5000	
200	G3VM-201AR/DR	4	1a	0.7	0.9	1000	110	1.0	0.5	2500	★
200	G3VM-201CR/FR	8	1a	1500 (3000) ^{*1}	0.25	1000	400	5.0	1.0	2500	
350	G3VM-351AY/DY	4	1a	100	35	1000	30	1.0	1.0	5000	
350	G3VM-351AY1/DY1	4	1a	100	35	1000	30	2.0	1.0	5000	
350	G3VM-2L/2FL	4	1a	120 ^{*2}	22	1000	40	1.0	1.0	2500	
350	G3VM-351A/D	4	1a	120	35	1000	30	1.0	1.0	2500	
350	G3VM-353A/D	4	1b	150	15	1000	85	1.0	3.0	2500	
350	G3VM-351B/E	6	1a	120 (240) ^{*1}	35	1000	30	1.0	1.0	2500	
350	G3VM-353B/E	6	1b	150 (300) ^{*1}	15	1000	85	1.0	3.0	2500	
350	G3VM-355CR/FR	8	1a1b	120	15	1000	65	1.0	3.0	2500	
350	G3VM-352C/F	8	2a	120	35	1000	30	1.0	1.0	2500	
350	G3VM-WL/WFL	8	2a	120 ^{*2}	22	1000	40	1.0	1.0	2500	
350	G3VM-354C/F	8	2b	150	15	1000	85	1.0	3.0	2500	
400	G3VM-401A/D	4	1a	120	18	1000	40	1.0	1.0	2500	
400	G3VM-401AY/DY	4	1a	120	22	1000	80	1.0	1.0	5000	
400	G3VM-401AY1/DY1	4	1a	120	22	1000	80	2.0	1.0	5000	
400	G3VM-401B/E	6	1a	120 (240) ^{*1}	17	1000	40	1.0	1.0	2500	
400	G3VM-401BY/EY	6	1a	120 (240) ^{*1}	17	1000	40	1.0	1.0	5000	
400	G3VM-401CR/FR	8	1a	400 (800) ^{*1}	3	1000	410	1.0	1.0	2500	
400	G3VM-402C/F	8	2a	120	18	1000	40	1.0	1.0	2500	
600	G3VM-601AY/DY	4	1a	90	45	1000	75	1.0	1.0	5000	
600	G3VM-601AY1/DY1	4	1a	90	45	1000	75	2.0	1.0	5000	
600	G3VM-601BY/EY	6	1a	100 (200) ^{*1}	30	1000	120	1.5	1.0	5000	
600	G3VM-601CR/FR	8	1a	600 (1200) ^{*1}	1.3	10000	4300	3.0	1.0	2500	

*1. Load current in case of connection C is shown in parentheses (DC load only) *2. Current-Limiting function (Limit current 150 mA Min. 300 mA Max.)
Note: Ambient operating temperature: ★ -40 to +110°C ◆ -40 to +105°C ○ -20 to +85°C, others: -40 to +85°C

Product lineup of MOS FET Relays

SOP (Small Outline Package)

Load Voltage (V) Max.	Model	Number of terminals	Contact form	Continuous load current (mA) Max.	Maximum resistance with output ON (Ohm) Typ.	Current leakage when the relay is open (nA) Max.	Capacitance between terminals (pF) Typ.	Turn-ON time (ms) Max.	Turn-OFF time (ms) Max.	Dielectric strength between I/O (Vrms)	
20	G3VM-21GR	4	1a	160	5	1	1	0.5	0.5	1500	○
20	G3VM-21GR1	4	1a	300	1	1	5	0.5	0.5	1500	○
20	G3VM-21HR	6	1a	2500 (5000) ^{*1}	0.02	10	1000	5.0	1.0	1500	
30	G3VM-31HR	6	1a	4000 (8000) ^{*1}	0.02	1000	1100	5.0	1.0	1500	
30	G3VM-31HR1	6	1a	4500 (9000) ^{*1}	0.022	1000	1200	2.0	0.5	1500	★
40	G3VM-41GR6	4	1a	120	10	1	1	0.5	0.5	1500	○
40	G3VM-41GR4	4	1a	250	2	1	5	0.5	0.5	1500	○
40	G3VM-41GR5	4	1a	300	1	1	10	0.5	0.5	1500	
40	G3VM-41GR8	4	1a	1000	0.1	1	300	3.0	0.5	1500	
40	G3VM-41HR	6	1a	2500 (5000) ^{*1}	0.03	10	1000	5.0	1.0	1500	
60	G3VM-61VY1 ^{*3}	4	1a	100	25	1000	10	5.0	5.0	3750	
60	G3VM-61G2	4	1a	400	1	1000	130	8.0	3.0	1500	
60	G3VM-61G3	4	1a	400	1	1000	130	10.0	5.0	1500	
60	G3VM-61VY2 ^{*3}	4	1a	500	1	1000	20	2.0	0.5	3750	★
60	G3VM-61VY3	4	1a	700	0.15	1000	100	3.0	0.5	3750	★
60	G3VM-61GR2	4	1a	1700	0.08	10	250	3.0	0.5	1500	
60	G3VM-61VR ^{*3}	4	1a	1400	0.13	1000	100	3.0	1.0	3750	★
60	G3VM-63G	4	1b	500	1	1000	100	1.0	3.0	1500	◆
60	G3VM-61H1	6	1a	400 (800) ^{*1}	1	1000	130	2.0	0.5	1500	
60	G3VM-61HR	6	1a	2300 (4600) ^{*1}	0.04	10	1000	5.0	1.0	1500	
60	G3VM-61HR1	6	1a	3300 (6600) ^{*1}	0.03	20	700	5.0	1.0	1500	
60	G3VM-61HR2	6	1a	4000 (8000) ^{*1}	0.028	1000	750	2.0	0.5	1500	★
60	G3VM-62J1	8	2a	400	1	1000	130	2.0	0.5	1500	
80	G3VM-81GR	4	1a	40	16	1	2.5	0.5	0.5	1500	○
80	G3VM-81GR1	4	1a	200	5	1	6.5	0.5	0.5	1500	○
80	G3VM-81G1	4	1a	350	1	1	30	0.5	0.5	1500	○
80	G3VM-81HR	6	1a	1250 (2500) ^{*1}	0.11	1.5	460	3.0	1.0	1500	○
100	G3VM-101HR	6	1a	1400 (2800) ^{*1}	0.1	10	1000	5.0	1.0	1500	
100	G3VM-101HR1	6	1a	2000 (4000) ^{*1}	0.045	1000	500	5.0	1.0	1500	
100	G3VM-101HR2	6	1a	3000 (6000) ^{*1}	0.05	1000	460	2.0	0.5	1500	★
200	G3VM-201G	4	1a	50	40	1	15	0.5	0.2	1500	
200	G3VM-201G1	4	1a	200	5	1000	90	8.0	3.0	1500	
200	G3VM-201G2	4	1a	200	5	1000	90	10.0	5.0	1500	
200	G3VM-S5	4	1a	200	5	1000	100	1.5	1.0	1500	
200	G3VM-201H1	6	1a	200 (400) ^{*1}	5	1000	100	1.5	1.0	1500	
200	G3VM-202J1	8	2a	200	5	1000	100	1.5	1.0	1500	
350	G3VM-351G1	4	1a	100	35	1000	35	5.0	3.0	1500	
350	G3VM-351VY ^{*3}	4	1a	110	35	1000	60	1.0	0.5	3750	★
350	G3VM-351GL	4	1a	120 ^{*2}	15	1000	70	1.0	1.0	1500	
350	G3VM-353G	4	1b	120	15	1000	65	1.0	3.0	1500	
350	G3VM-351H	6	1a	110 (220) ^{*1}	35	1000	30	1.0	1.0	1500	
350	G3VM-353H	6	1b	120 (240) ^{*1}	15	1000	65	1.0	3.0	1500	
350	G3VM-355JR	8	1a1b	120	15	1000	65	1.0	3.0	1500	
350	G3VM-352J	8	2a	110	35	1000	30	1.0	1.0	1500	
350	G3VM-354J	8	2b	120	15	1000	65	1.0	3.0	1500	
400	G3VM-401G1	4	1a	100	18	1000	70	10.0	5.0	1500	
400	G3VM-401G	4	1a	120	17	1000	70	1.0	1.0	1500	
400	G3VM-401VY	4	1a	110	40	65	30	1.0	0.5	1500	★
400	G3VM-401H	6	1a	120 (240) ^{*1}	17	1000	70	1.0	1.0	1500	
400	G3VM-402J	8	2a	120	17	1000	70	1.0	1.0	1500	
600	G3VM-601G1	4	1a	70	35	1000	75	10.0	5.0	1500	
600	G3VM-601G	4	1a	90	45	1000	75	8.0	3.0	1500	

*1. Load current in case of connection C is shown in parentheses (DC load only) *2. Current-Limiting function (Limit current 150 mA Min. 300 mA Max.) *3. VY1,VY2,VY3 and VR types: Special SOP4 pin package
Note: Ambient operating temperature: ★ -40 to +110°C ◆ -40 to +105°C ○ -20 to +85°C, others: -40 to +85°C

Product lineup of MOS FET Relays

Please refer to our web site or datasheet for more information such as measurement conditions.

DIP (Dual Inline Package)

Load Voltage (V) Max.	Model	Number of terminals	Contact form	Continuous load current (mA) Max.	Maximum resistance with output ON (Ohm) Typ.	Current leakage when the relay is open (nA) Max.	Capacitance between terminals (pF) Typ.	Turn-ON time (ms) Max.	Turn-OFF time (ms) Max.	Dielectric strength between I/O (Vrms)	
20	G3VM-21AR/DR	4	1a	3000	0.04	1000	300	5.0	1.0	2500	
20	G3VM-21BR/ER	6	1a	4000 (8000) ^{*1}	0.02	1000	1000	5.0	1.0	2500	
30	G3VM-31AR/DR	4	1a	4000	0.025	1000	450	3.0	1.0	2500	★
30	G3VM-31BR/ER	6	1a	5000 (8000) ^{*1}	0.02	1000	1100	5.0	0.5	2500	★
40	G3VM-41AY/DY	4	1a	2000	0.09	1000	300	5.0	1.0	5000	
40	G3VM-41AY1/DY1	4	1a	2000	0.09	1000	300	5.0	1.0	5000	
40	G3VM-41AR/DR	4	1a	2500	0.05	1000	300	5.0	1.0	2500	
40	G3VM-41BR/ER	6	1a	3500 (7000) ^{*1}	0.03	1000	1000	5.0	1.0	2500	
60	G3VM-61A1/D1	4	1a	500	1	1000	130	2.0	0.5	2500	
60	G3VM-61AY/DY	4	1a	500	0.6	1000	130	1.0	1.0	5000	
60	G3VM-61AY1/DY1	4	1a	500	0.6	1000	130	3.0	1.0	5000	
60	G3VM-61AR/DR	4	1a	2000	0.08	1000	250	5.0	1.0	2500	
60	G3VM-61AR1/DR1	4	1a	3000	0.045	1000	250	2.0	1.0	2500	★
60	G3VM-61B1/E1	6	1a	500 (1000) ^{*1}	1	1000	130	2.0	0.5	2500	
60	G3VM-61BR/ER	6	1a	2500	0.065	10	400	1.5	0.4	2500	○
60	G3VM-61BR1/ER1	6	1a	3000 (6000) ^{*1}	0.04	1000	1000	5.0	1.0	2500	
60	G3VM-61BR2/ER2	6	1a	4000 (8000) ^{*1}	0.035	1000	640	5.0	0.5	2500	★
60	G3VM-61CR1/FR1	8	1a	5000(10000) ^{*1}	0.022	10000	850	5.0	1.0	2500	
60	G3VM-62C1/F1	8	2a	500	1	1000	130	2.0	0.5	2500	
100	G3VM-101AR/DR	4	1a	1000	0.25	1000	200	5.0	1.0	2500	
100	G3VM-101AR1/DR1	4	1a	2000	0.11	1000	110	2.0	0.5	2500	★
100	G3VM-101BR/ER	6	1a	2000 (4000) ^{*1}	0.1	1000	1000	5.0	1.0	2500	
100	G3VM-101BR1/ER1	6	1a	3500 (7000) ^{*1}	0.05	1000	450	5.0	0.5	2500	★
100	G3VM-101CR/FR	8	1a	3000 (6000) ^{*1}	0.06	1000	720	5.0	1.0	2500	
200	G3VM-201AY/DY	4	1a	250	5	1000	90	1.0	1.0	5000	
200	G3VM-201AY1/DY1	4	1a	250	5	1000	90	3.0	1.0	5000	
200	G3VM-201AR/DR	4	1a	0.7	0.9	1000	110	1.0	0.5	2500	★
200	G3VM-201CR/FR	8	1a	1500 (3000) ^{*1}	0.25	1000	400	5.0	1.0	2500	
350	G3VM-351AY/DY	4	1a	100	35	1000	30	1.0	1.0	5000	
350	G3VM-351AY1/DY1	4	1a	100	35	1000	30	2.0	1.0	5000	
350	G3VM-2L/2FL	4	1a	120 ^{*2}	22	1000	40	1.0	1.0	2500	
350	G3VM-351A/D	4	1a	120	35	1000	30	1.0	1.0	2500	
350	G3VM-353A/D	4	1b	150	15	1000	85	1.0	3.0	2500	
350	G3VM-351B/E	6	1a	120 (240) ^{*1}	35	1000	30	1.0	1.0	2500	
350	G3VM-353B/E	6	1b	150 (300) ^{*1}	15	1000	85	1.0	3.0	2500	
350	G3VM-355CR/FR	8	1a1b	120	15	1000	65	1.0	3.0	2500	
350	G3VM-352C/F	8	2a	120	35	1000	30	1.0	1.0	2500	
350	G3VM-WL/WFL	8	2a	120 ^{*2}	22	1000	40	1.0	1.0	2500	
350	G3VM-354C/F	8	2b	150	15	1000	85	1.0	3.0	2500	
400	G3VM-401A/D	4	1a	120	18	1000	40	1.0	1.0	2500	
400	G3VM-401AY/DY	4	1a	120	22	1000	80	1.0	1.0	5000	
400	G3VM-401AY1/DY1	4	1a	120	22	1000	80	2.0	1.0	5000	
400	G3VM-401B/E	6	1a	120 (240) ^{*1}	17	1000	40	1.0	1.0	2500	
400	G3VM-401BY/EY	6	1a	120 (240) ^{*1}	17	1000	40	1.0	1.0	5000	
400	G3VM-401CR/FR	8	1a	400 (800) ^{*1}	3	1000	410	1.0	1.0	2500	
400	G3VM-402C/F	8	2a	120	18	1000	40	1.0	1.0	2500	
600	G3VM-601AY/DY	4	1a	90	45	1000	75	1.0	1.0	5000	
600	G3VM-601AY1/DY1	4	1a	90	45	1000	75	2.0	1.0	5000	
600	G3VM-601BY/EY	6	1a	100 (200) ^{*1}	30	1000	120	1.5	1.0	5000	
600	G3VM-601CR/FR	8	1a	600 (1200) ^{*1}	1.3	10000	4300	3.0	1.0	2500	

*1. Load current in case of connection C is shown in parentheses (DC load only) *2. Current-Limiting function (Limit current 150 mA Min. 300 mA Max.)
Note: Ambient operating temperature: ★ -40 to +110°C ◆ -40 to +105°C ○ -20 to +85°C, others: -40 to +85°C

Product lineup of MOS FET Relays

SOP (Small Outline Package)

Load Voltage (V) Max.	Model	Number of terminals	Contact form	Continuous load current (mA) Max.	Maximum resistance with output ON (Ohm) Typ.	Current leakage when the relay is open (nA) Max.	Capacitance between terminals (pF) Typ.	Turn-ON time (ms) Max.	Turn-OFF time (ms) Max.	Dielectric strength between I/O (Vrms)	
20	G3VM-21GR	4	1a	160	5	1	1	0.5	0.5	1500	○
20	G3VM-21GR1	4	1a	300	1	1	5	0.5	0.5	1500	○
20	G3VM-21HR	6	1a	2500 (5000) ^{*1}	0.02	10	1000	5.0	1.0	1500	
30	G3VM-31HR	6	1a	4000 (8000) ^{*1}	0.02	1000	1100	5.0	1.0	1500	
30	G3VM-31HR1	6	1a	4500 (9000) ^{*1}	0.022	1000	1200	2.0	0.5	1500	★
40	G3VM-41GR6	4	1a	120	10	1	1	0.5	0.5	1500	○
40	G3VM-41GR4	4	1a	250	2	1	5	0.5	0.5	1500	○
40	G3VM-41GR5	4	1a	300	1	1	10	0.5	0.5	1500	
40	G3VM-41GR8	4	1a	1000	0.1	1	300	3.0	0.5	1500	
40	G3VM-41HR	6	1a	2500 (5000) ^{*1}	0.03	10	1000	5.0	1.0	1500	
60	G3VM-61VY1 ^{*3}	4	1a	100	25	1000	10	5.0	5.0	3750	
60	G3VM-61G2	4	1a	400	1	1000	130	8.0	3.0	1500	
60	G3VM-61G3	4	1a	400	1	1000	130	10.0	5.0	1500	
60	G3VM-61VY2 ^{*3}	4	1a	500	1	1000	20	2.0	0.5	3750	★
60	G3VM-61VY3	4	1a	700	0.15	1000	100	3.0	0.5	3750	★
60	G3VM-61GR2	4	1a	1700	0.08	10	250	3.0	0.5	1500	
60	G3VM-61VR ^{*3}	4	1a	1400	0.13	1000	100	3.0	1.0	3750	★
60	G3VM-63G	4	1b	500	1	1000	100	1.0	3.0	1500	◆
60	G3VM-61H1	6	1a	400 (800) ^{*1}	1	1000	130	2.0	0.5	1500	
60	G3VM-61HR	6	1a	2300 (4600) ^{*1}	0.04	10	1000	5.0	1.0	1500	
60	G3VM-61HR1	6	1a	3300 (6600) ^{*1}	0.03	20	700	5.0	1.0	1500	
60	G3VM-61HR2	6	1a	4000 (8000) ^{*1}	0.028	1000	750	2.0	0.5	1500	★
60	G3VM-62J1	8	2a	400	1	1000	130	2.0	0.5	1500	
80	G3VM-81GR	4	1a	40	16	1	2.5	0.5	0.5	1500	○
80	G3VM-81GR1	4	1a	200	5	1	6.5	0.5	0.5	1500	○
80	G3VM-81G1	4	1a	350	1	1	30	0.5	0.5	1500	○
80	G3VM-81HR	6	1a	1250 (2500) ^{*1}	0.11	1.5	460	3.0	1.0	1500	○
100	G3VM-101HR	6	1a	1400 (2800) ^{*1}	0.1	10	1000	5.0	1.0	1500	
100	G3VM-101HR1	6	1a	2000 (4000) ^{*1}	0.045	1000	500	5.0	1.0	1500	
100	G3VM-101HR2	6	1a	3000 (6000) ^{*1}	0.05	1000	460	2.0	0.5	1500	★
200	G3VM-201G	4	1a	50	40	1	15	0.5	0.2	1500	
200	G3VM-201G1	4	1a	200	5	1000	90	8.0	3.0	1500	
200	G3VM-201G2	4	1a	200	5	1000	90	10.0	5.0	1500	
200	G3VM-S5	4	1a	200	5	1000	100	1.5	1.0	1500	
200	G3VM-201H1	6	1a	200 (400) ^{*1}	5	1000	100	1.5	1.0	1500	
200	G3VM-202J1	8	2a	200	5	1000	100	1.5	1.0	1500	
350	G3VM-351G1	4	1a	100	35	1000	35	5.0	3.0	1500	
350	G3VM-351VY ^{*3}	4	1a	110	35	1000	60	1.0	0.5	3750	★
350	G3VM-351GL	4	1a	120 ^{*2}	15	1000	70	1.0	1.0	1500	
350	G3VM-353G	4	1b	120	15	1000	65	1.0	3.0	1500	
350	G3VM-351H	6	1a	110 (220) ^{*1}	35	1000	30	1.0	1.0	1500	
350	G3VM-353H	6	1b	120 (240) ^{*1}	15	1000	65	1.0	3.0	1500	
350	G3VM-355JR	8	1a1b	120	15	1000	65	1.0	3.0	1500	
350	G3VM-352J	8	2a	110	35	1000	30	1.0	1.0	1500	
350	G3VM-354J	8	2b	120	15	1000	65	1.0	3.0	1500	
400	G3VM-401G1	4	1a	100	18	1000	70	10.0	5.0	1500	
400	G3VM-401G	4	1a	120	17	1000	70	1.0	1.0	1500	
400	G3VM-401VY	4	1a	110	40	65	30	1.0	0.5	1500	★
400	G3VM-401H	6	1a	120 (240) ^{*1}	17	1000	70	1.0	1.0	1500	
400	G3VM-402J	8	2a	120	17	1000	70	1.0	1.0	1500	
600	G3VM-601G1	4	1a	70	35	1000	75	10.0	5.0	1500	
600	G3VM-601G	4	1a	90	45	1000	75	8.0	3.0	1500	

*1. Load current in case of connection C is shown in parentheses (DC load only) *2. Current-Limiting function (Limit current 150 mA Min. 300 mA Max.) *3. VY1,VY2,VY3 and VR types: Special SOP4 pin package
Note: Ambient operating temperature: ★ -40 to +110°C ◆ -40 to +105°C ○ -20 to +85°C, others: -40 to +85°C

Product lineup of MOS FET Relays

Package dimensions/Appearance

(Unit: mm)

SSOP (Shrink Small Outline Package)

Load Voltage (V) Max.	Model	Number of terminals	Contact form	Continuous load current (mA) Max.	Maximum resistance with output ON (Ohm) Typ.	Current leakage when the relay is open (nA) Max.	Capacitance between terminals (pF) Typ.	Turn-ON time (ms) Max.	Turn-OFF time (ms) Max.	Dielectric strength between I/O (Vrms)
20	G3VM-21LR	4	1a	100	5	1	1	0.5	0.5	1500
20	G3VM-21LR10	4	1a	200	3	0.2	0.8	0.2	0.2	1500
20	G3VM-21LR1	4	1a	450	0.8	1	5	0.5	0.5	1500
20	G3VM-21LR11	4	1a	900	0.18	1	40	2.0	1.0	1500
40	G3VM-41LR6	4	1a	120	10	1	1	0.5	0.5	1500
40	G3VM-41LR10	4	1a	120	12	0.2	0.45	0.2	0.3	1500
40	G3VM-41LR11	4	1a	140	7	0.2	0.7	0.2	0.2	1500
40	G3VM-41LR4	4	1a	250	2	1	5	0.5	0.5	1500
40	G3VM-41LR5	4	1a	300	1	1	10	0.5	0.5	1500
60	G3VM-61LR	4	1a	400	1	1000	20	1.0	1.0	1500
80	G3VM-81LR	4	1a	120	7.5	0.2	5	0.25	0.2	1500
100	G3VM-101LR	4	1a	80	8	0.2	6	0.3	0.3	1500

Note: Ambient operating temperature: -20 to +85°C

USOP (Ultra Small Outline Package)

Load Voltage (V) Max.	Model	Number of terminals	Contact form	Continuous load current (mA) Max.	Maximum resistance with output ON (Ohm) Typ.	Current leakage when the relay is open (nA) Max.	Capacitance between terminals (pF) Typ.	Turn-ON time (ms) Max.	Turn-OFF time (ms) Max.	Dielectric strength between I/O (Vrms)
20	G3VM-21PR10	4	1a	200	3	1	0.8	0.2	0.2	500
20	G3VM-21PR1	4	1a	450	0.6	1	5	0.5	0.5	500
20	G3VM-21PR11	4	1a	900	0.18	1	40	2.0	1.0	500
40	G3VM-41PR12	4	1a	100	15	1	0.3	0.2	0.2	500
40	G3VM-41PR10	4	1a	120	12	1	0.45	0.2	0.3	500
40	G3VM-41PR6	4	1a	120	10	0.2	1	0.2	0.3	500
40	G3VM-41PR11	4	1a	140	7	1	0.7	0.2	0.2	500
40	G3VM-41PR5	4	1a	300	1	1	10	0.5	0.3	500
50	G3VM-51PR	4	1a	300	1	1	12	0.5	0.4	500
60	G3VM-61PR1	4	1a	120	10	1	0.7	0.2	0.2	500
60	G3VM-61PR	4	1a	400	1	1	20	0.5	0.5	500
75	G3VM-71PR	4	1a	400	1	1	30	2.0	1.0	500
80	G3VM-81PR	4	1a	120	7	0.02	5	0.5	0.2	500
100	G3VM-101PR	4	1a	100	8	0.2	6	0.3	0.3	500

Note: Ambient operating temperature: -40 to +85°C

VSON(R) (Very Small Outline Package Non-leaded with Resistance) Voltage driven type

Load Voltage (V) Max.	Model	Number of terminals	Contact form	Continuous load current (mA) Max.	Maximum resistance with output ON (Ohm) Typ.	Current leakage when the relay is open (nA) Max.	Capacitance between terminals (pF) Typ.	Turn-ON time (ms) Max.	Turn-OFF time (ms) Max.	Recommended Operating voltage (V) Typ.	Dielectric strength between I/O (Vrms)
20	G3VM-21UV11	4	1a	1000	0.18	1	40	2.0	1.0	5	500
50	G3VM-51UV	4	1a	300	1	1	12	0.5	0.4	5	500
60	G3VM-61UV	4	1a	400	1	1	20	0.5	0.5	5	500

Note: Ambient operating temperature: -40 to +110°C

VSON (Very Small Outline Package Non-leaded)

Load Voltage (V) Max.	Model	Number of terminals	Contact form	Continuous load current (mA) Max.	Maximum resistance with output ON (Ohm) Typ.	Current leakage when the relay is open (nA) Max.	Capacitance between terminals (pF) Typ.	Turn-ON time (ms) Max.	Turn-OFF time (ms) Max.	Dielectric strength between I/O (Vrms)
20	G3VM-21UR10	4	1a	200	3	1	0.8	0.2	0.2	500
20	G3VM-21UR1	4	1a	450	0.8	1	5	0.4	0.4	500
20	G3VM-21UR11	4	1a	1000	0.18	1	40	2.0	1.0	500
40	G3VM-41UR12	4	1a	100	15	1	0.3	0.2	0.2	500
40	G3VM-41UR10	4	1a	120	12	1	0.45	0.2	0.3	500
40	G3VM-41UR11	4	1a	140	7	1	0.7	0.2	0.2	500
50	G3VM-51UR	4	1a	300	1	1	12	0.5	0.4	500
60	G3VM-61UR1	4	1a	120	10	1	0.7	0.2	0.2	500
60	G3VM-61UR	4	1a	400	1	1	20	0.5	0.5	500
80	G3VM-81UR	4	1a	120	7	0.02	5	0.5	0.2	500
80	G3VM-81UR1	4	1a	200	6	1	6.5	0.4	0.4	500
100	G3VM-101UR	4	1a	100	8	0.2	6	0.3	0.3	500

Note: Ambient operating temperature: -40 to +110°C

S-VSON (Super - Very Small Outline Package Non-leaded)

Load Voltage (V) Max.	Model	Number of terminals	Contact form	Continuous load current (mA) Max.	Maximum resistance with output ON (Ohm) Typ.	Current leakage when the relay is open (nA) Max.	Capacitance between terminals (pF) Typ.	Turn-ON time (ms) Max.	Turn-OFF time (ms) Max.	Dielectric strength between I/O (Vrms)
30	G3VM-31QR	4	1a	1500	0.1	1	120	2.0	1.0	500
40	G3VM-41QR10*	4	1a	120	11	1	0.45	0.2	0.3	500
60	G3VM-61QR	4	1a	400	1.1	1	12	0.5	0.3	500
60	G3VM-61QR2	4	1a	1000	0.2	1	80	2.0	0.3	500
100	G3VM-101QR1	4	1a	650	0.4	1	50	2.0	0.3	500

* 41QR10 type: S-VSON(L)package (Low profile type) Note: Ambient operating temperature: -40 to +110°C

S-VSON (Super - Very Small Outline Package Non-leaded) Voltage driven type

Load Voltage (V) Max.	Model	Number of terminals	Contact form	Continuous load current (mA) Max.	Maximum resistance with output ON (Ohm) Typ.	Current leakage when the relay is open (nA) Max.	Capacitance between terminals (pF) Typ.	Turn-ON time (ms) Max.	Turn-OFF time (ms) Max.	Recommended Operating voltage (V) Typ.	Dielectric strength between I/O (Vrms)
30	G3VM-31QVH	4	1a	1500	0.1	1	120	2	0.2	5	500
30	G3VM-31QVL	4	1a	1500	0.1	1	120	2	0.2	2.5	500
60	G3VM-61QV2H	4	1a	1000	0.2	1	80	2	0.2	5	500
60	G3VM-61QV2L	4	1a	1000	0.2	1	80	1	0.2	2.5	500
60	G3VM-61QVH	4	1a	400	1	1	20 (Max.)	0.5	0.2	5	500

* S-VSON(L)package (Low profile type) Note: Ambient operating temperature: -40 to +110°C

DIP (Dual Inline Package)

PCB Terminals

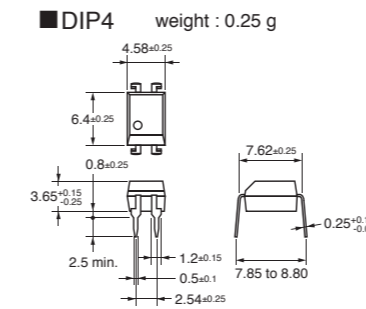

Surface-mounting Terminals

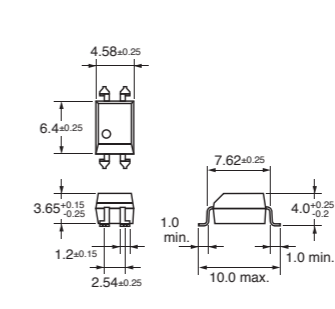

■ DIP6 weight : 0.4 g

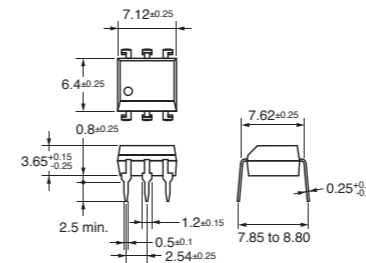

(Exclude G3VM-61BR/ER)

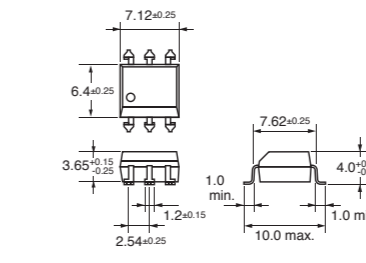

■ DIP8 weight : 0.54 g

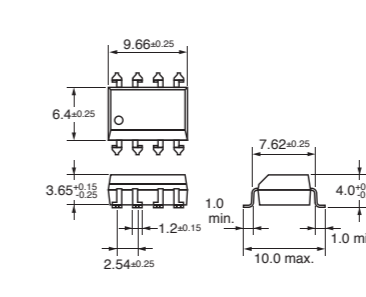
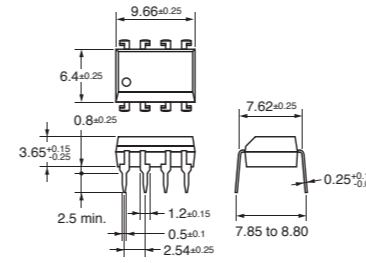

SOP (Small Outline Package)

Surface-mounting Terminals

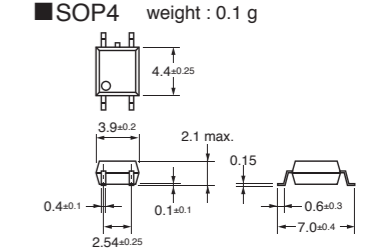

■ Special SOP4 pin weight : 0.1 g

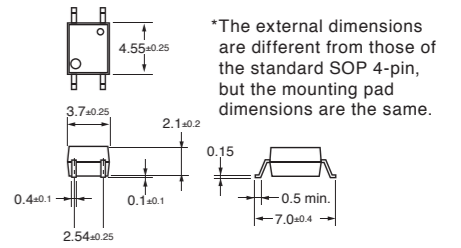

■ SOP6 weight : 0.13 g

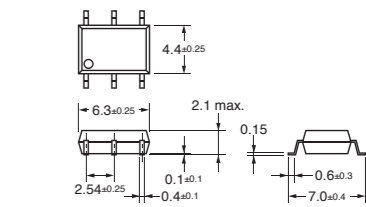

■ SOP8 weight : 0.2 g

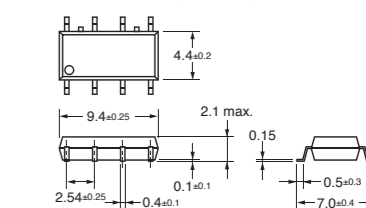

SSOP (Shrink Small Outline Package)

Surface-mounting Terminals

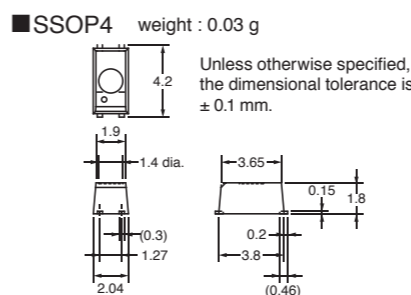

VSON (Very Small Outline Non-leaded)

Surface-mounting Terminals

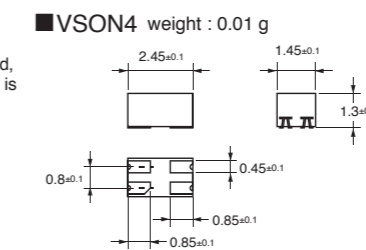

VSON(R) (Very Small Outline Non-Leaded with Resistor)

Surface-mounting Terminals

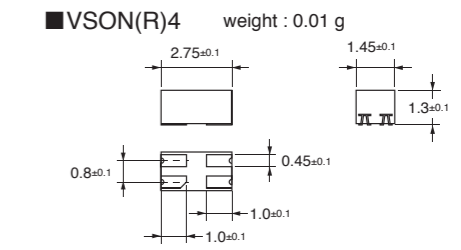

USOP (Ultra Small Outline Package)

Surface-mounting Terminals

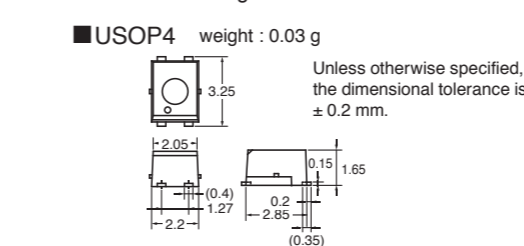

S-VSON (Super Very Small Outline Non-leaded)

Surface-mounting Terminals

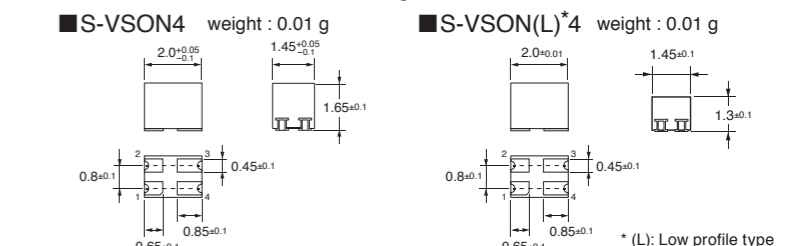

MOS FET Relays

MOS FET Relays

Product lineup of MOS FET Relays

Package dimensions/Appearance

(Unit: mm)

SSOP (Shrink Small Outline Package)

Load Voltage (V) Max.	Model	Number of terminals	Contact form	Continuous load current (mA) Max.	Maximum resistance with output ON (Ohm) Typ.	Current leakage when the relay is open (nA) Max.	Capacitance between terminals (pF) Typ.	Turn-ON time (ms) Max.	Turn-OFF time (ms) Max.	Dielectric strength between I/O (Vrms)
20	G3VM-21LR	4	1a	100	5	1	1	0.5	0.5	1500
20	G3VM-21LR10	4	1a	200	3	0.2	0.8	0.2	0.2	1500
20	G3VM-21LR1	4	1a	450	0.8	1	5	0.5	0.5	1500
20	G3VM-21LR11	4	1a	900	0.18	1	40	2.0	1.0	1500
40	G3VM-41LR6	4	1a	120	10	1	1	0.5	0.5	1500
40	G3VM-41LR10	4	1a	120	12	0.2	0.45	0.2	0.3	1500
40	G3VM-41LR11	4	1a	140	7	0.2	0.7	0.2	0.2	1500
40	G3VM-41LR4	4	1a	250	2	1	5	0.5	0.5	1500
40	G3VM-41LR5	4	1a	300	1	1	10	0.5	0.5	1500
60	G3VM-61LR	4	1a	400	1	1000	20	1.0	1.0	1500
80	G3VM-81LR	4	1a	120	7.5	0.2	5	0.25	0.2	1500
100	G3VM-101LR	4	1a	80	8	0.2	6	0.3	0.3	1500

Note: Ambient operating temperature: -20 to +85°C

USOP (Ultra Small Outline Package)

Load Voltage (V) Max.	Model	Number of terminals	Contact form	Continuous load current (mA) Max.	Maximum resistance with output ON (Ohm) Typ.	Current leakage when the relay is open (nA) Max.	Capacitance between terminals (pF) Typ.	Turn-ON time (ms) Max.	Turn-OFF time (ms) Max.	Dielectric strength between I/O (Vrms)
20	G3VM-21PR10	4	1a	200	3	1	0.8	0.2	0.2	500
20	G3VM-21PR1	4	1a	450	0.6	1	5	0.5	0.5	500
20	G3VM-21PR11	4	1a	900	0.18	1	40	2.0	1.0	500
40	G3VM-41PR12	4	1a	100	15	1	0.3	0.2	0.2	500
40	G3VM-41PR10	4	1a	120	12	1	0.45	0.2	0.3	500
40	G3VM-41PR6	4	1a	120	10	0.2	1	0.2	0.3	500
40	G3VM-41PR11	4	1a	140	7	1	0.7	0.2	0.2	500
40	G3VM-41PR5	4	1a	300	1	1	10	0.5	0.3	500
50	G3VM-51PR	4	1a	300	1	1	12	0.5	0.4	500
60	G3VM-61PR1	4	1a	120	10	1	0.7	0.2	0.2	500
60	G3VM-61PR	4	1a	400	1	1	20	0.5	0.5	500
75	G3VM-71PR	4	1a	400	1	1	30	2.0	1.0	500
80	G3VM-81PR	4	1a	120	7	0.02	5	0.5	0.2	500
100	G3VM-101PR	4	1a	100	8	0.2	6	0.3	0.3	500

Note: Ambient operating temperature: -40 to +85°C

VSON(R) (Very Small Outline Package Non-leaded with Resistance) Voltage driven type

Load Voltage (V) Max.	Model	Number of terminals	Contact form	Continuous load current (mA) Max.	Maximum resistance with output ON (Ohm) Typ.	Current leakage when the relay is open (nA) Max.	Capacitance between terminals (pF) Typ.	Turn-ON time (ms) Max.	Turn-OFF time (ms) Max.	Recommended Operating voltage (V) Typ.	Dielectric strength between I/O (Vrms)
20	G3VM-21UV11	4	1a	1000	0.18	1	40	2.0	1.0	5	500
50	G3VM-51UV	4	1a	300	1	1	12	0.5	0.4	5	500
60	G3VM-61UV	4	1a	400	1	1	20	0.5	0.5	5	500

Note: Ambient operating temperature: -40 to +110°C

VSON (Very Small Outline Package Non-leaded)

Load Voltage (V) Max.	Model	Number of terminals	Contact form	Continuous load current (mA) Max.	Maximum resistance with output ON (Ohm) Typ.	Current leakage when the relay is open (nA) Max.	Capacitance between terminals (pF) Typ.	Turn-ON time (ms) Max.	Turn-OFF time (ms) Max.	Dielectric strength between I/O (Vrms)
20	G3VM-21UR10	4	1a	200	3	1	0.8	0.2	0.2	500
20	G3VM-21UR1	4	1a	450	0.8	1	5	0.4	0.4	500
20	G3VM-21UR11	4	1a	1000	0.18	1	40	2.0	1.0	500
40	G3VM-41UR12	4	1a	100	15	1	0.3	0.2	0.2	500
40	G3VM-41UR10	4	1a	120	12	1	0.45	0.2	0.3	500
40	G3VM-41UR11	4	1a	140	7	1	0.7	0.2	0.2	500
50	G3VM-51UR	4	1a	300	1	1	12	0.5	0.4	500
60	G3VM-61UR1	4	1a	120	10	1	0.7	0.2	0.2	500
60	G3VM-61UR	4	1a	400	1	1	20	0.5	0.5	500
80	G3VM-81UR	4	1a	120	7	0.02	5	0.5	0.2	500
80	G3VM-81UR1	4	1a	200	6	1	6.5	0.4	0.4	500
100	G3VM-101UR	4	1a	100	8	0.2	6	0.3	0.3	500

Note: Ambient operating temperature: -40 to +110°C

S-VSON (Super - Very Small Outline Package Non-leaded)

Load Voltage (V) Max.	Model	Number of terminals	Contact form	Continuous load current (mA) Max.	Maximum resistance with output ON (Ohm) Typ.	Current leakage when the relay is open (nA) Max.	Capacitance between terminals (pF) Typ.	Turn-ON time (ms) Max.	Turn-OFF time (ms) Max.	Dielectric strength between I/O (Vrms)
30	G3VM-31QR	4	1a	1500	0.1	1	120	2.0	1.0	500
40	G3VM-41QR10*	4	1a	120	11	1	0.45	0.2	0.3	500
60	G3VM-61QR	4	1a	400	1.1	1	12	0.5	0.3	500
60	G3VM-61QR2	4	1a	1000	0.2	1	80	2.0	0.3	500
100	G3VM-101QR1	4	1a	650	0.4	1	50	2.0	0.3	500

* 41QR10 type: S-VSON(L)package (Low profile type) Note: Ambient operating temperature: -40 to +110°C

S-VSON (Super - Very Small Outline Package Non-leaded) Voltage driven type

Load Voltage (V) Max.	Model	Number of terminals	Contact form	Continuous load current (mA) Max.	Maximum resistance with output ON (Ohm) Typ.	Current leakage when the relay is open (nA) Max.	Capacitance between terminals (pF) Typ.	Turn-ON time (ms) Max.	Turn-OFF time (ms) Max.	Recommended Operating voltage (V) Typ.	Dielectric strength between I/O (Vrms)
30	G3VM-31QVH	4	1a	1500	0.1	1	120	2	0.2	5	500
30	G3VM-31QVL	4	1a	1500	0.1	1	120	2	0.2	2.5	500
60	G3VM-61QV2H	4	1a	1000	0.2	1	80	2	0.2	5	500
60	G3VM-61QV2L	4	1a	1000	0.2	1	80	1	0.2	2.5	500
60	G3VM-61QVH	4	1a	400	1	1	20 (Max.)	0.5	0.2	5	500

* S-VSON(L)package (Low profile type) Note: Ambient operating temperature: -40 to +110°C

DIP (Dual Inline Package)

PCB Terminals

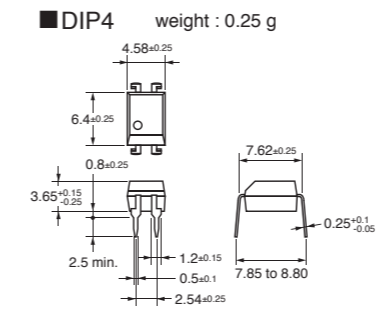

Surface-mounting Terminals

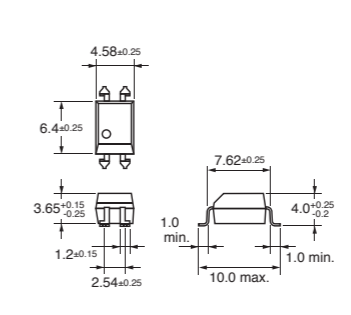

■ DIP6 weight : 0.4 g

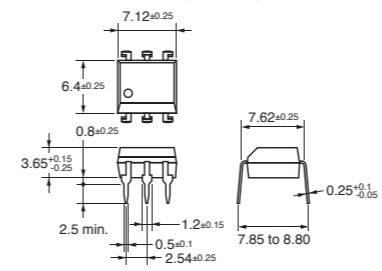

(Exclude G3VM-61BR/ER)

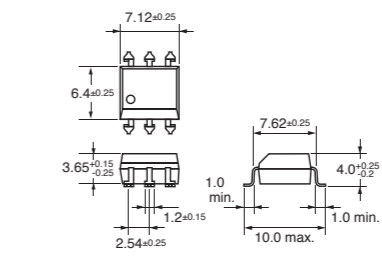

■ DIP8 weight : 0.54 g

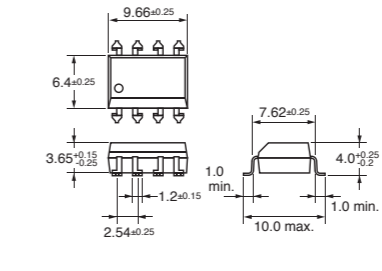
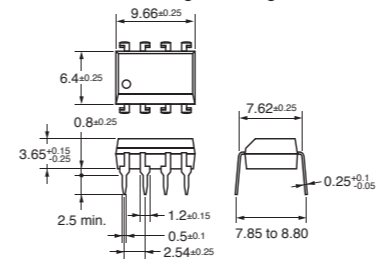

SOP (Small Outline Package)

Surface-mounting Terminals

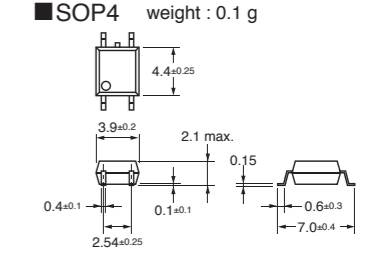

■ Special SOP4 pin weight : 0.1 g

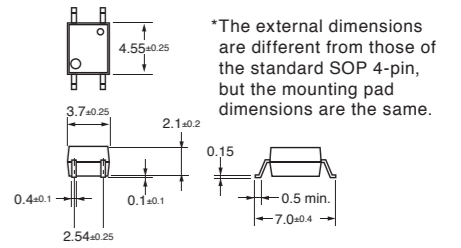

■ SOP6 weight : 0.13 g

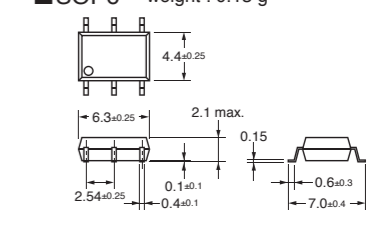

■ SOP8 weight : 0.2 g

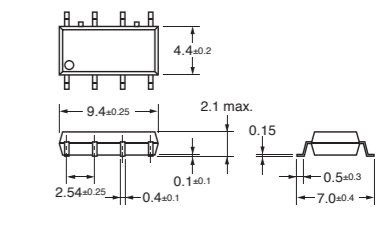

SSOP (Shrink Small Outline Package)

Surface-mounting Terminals

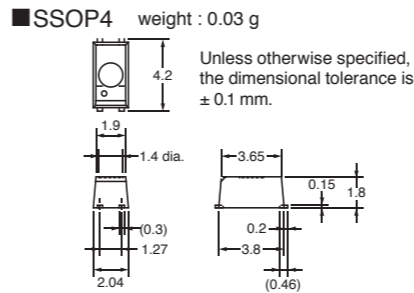

VSON (Very Small Outline Non-leaded)

Surface-mounting Terminals

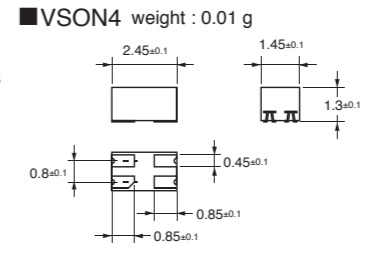

VSON(R) (Very Small Outline Non-Leaded with Resistor)

Surface-mounting Terminals

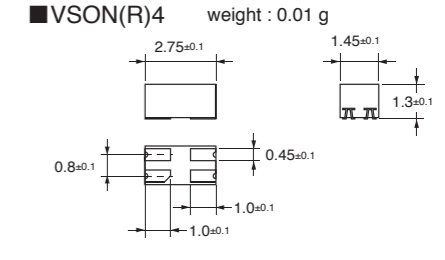

USOP (Ultra Small Outline Package)

Surface-mounting Terminals

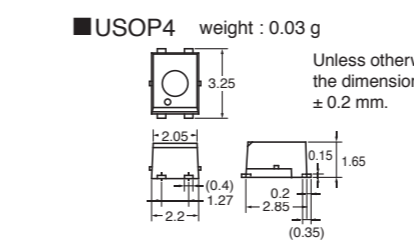

S-VSON (Super Very Small Outline Non-leaded)

Surface-mounting Terminals

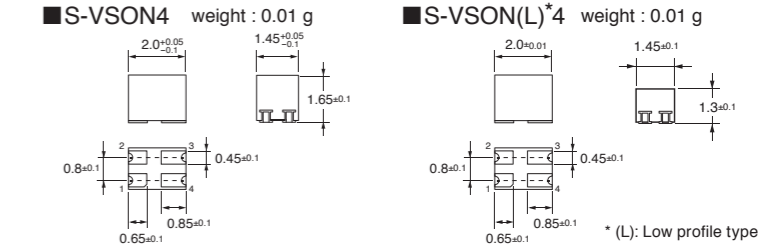

A wide range of contact forms and functions
Over 180 different models available

G3VM MOS FET RELAYS

SELECTION GUIDE

Please check each region's Terms & Conditions by region website.

OMRON Corporation
Electronic and Mechanical Components Company

Regional Contact

Americas
<https://www.components.omron.com/>
Asia-Pacific
<https://ecb.omron.com.sg/>
Korea
<https://www.omron-ecb.co.kr/>

Europe
<http://components.omron.eu/>
China
<https://www.ecb.omron.com.cn/>
Japan
<https://www.omron.co.jp/ecb/>

What's NEW!

MOS FET Relay Module is now available

Very small packages (VSON(R), S-VSON(L)) are now available

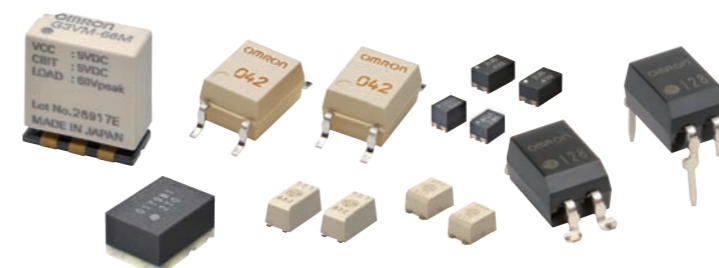

G3VM
MOS FET Relays
MOS FET Relay Modules

X-ON Electronics

Largest Supplier of Electrical and Electronic Components

Click to view similar products for [General Purpose Relays](#) category:

Click to view products by [Omron](#) manufacturer:

Other Similar products are found below :

[PCN-105D3MH,000](#) [59641F200](#) [5JO-1000CD-SIL](#) [5X827E](#) [5X837F](#) [5X840F](#) [5X842F](#) [5X848E](#) [LY2N-AC120](#) [LY2-US-AC120](#) [M115C60](#)
[M115N010](#) [M115N0150](#) [603-12D](#) [60HE1-5DC](#) [60HE2S-12DC](#) [61211T0B4](#) [61212T400](#) [61222Q400](#) [61243B600](#) [61243C500](#) [61243Q400](#)
[61311BOA2](#) [61311BOA6](#) [61311BOA8](#) [61311C0A2](#) [61311COA1](#) [61311COA6](#) [61311F0A2](#) [61311QOA1](#) [61311QOA4](#) [61311T0D6](#)
[61311TOA6](#) [61311TOA7](#) [61311TOB3](#) [61311TOB4](#) [61311U0A6](#) [61312Q600](#) [61312T400](#) [61312T600](#) [61313U200](#) [61313U400](#) [61322T400](#)
[61332C400](#) [61343C200](#) [61343C600](#) [61343Q200](#) [61343T100](#) [61343T200](#) [61343T400](#)