

# G5PZ-X

PCB Power Relay



## Compact Power Relay that Enables Bidirectional Opening/Closing of 200 VDC, 20 A



- 400 VDC, 20 A / 450 VDC 16 A bidirectional opening/closing is also possible through a contact series connection between two product units
- The 15.2 mm (W) slim size enables opening/closing of 200 VDC, 20 A regardless of the polarity
- High sensitivity of 530 mW coil consumption (further energy-saving effect is realized in an operating environment with a holding voltage of 50%)
- Min. 5.5 mm of insulation distance between the coil and contacts, and high insulation of 10 kV impulse withstand voltage
- A rating of two-contact series connection is acquired through UL/TÜV/CQC

### Model Number Legend

G5PZ-1A□-X  
1 2 3

1. Number of Poles      2. Contact Form      3. Rating  
 1 : 1-pole                  A : SPST-NO (1a)                  None : Flux protection

### Application Examples

- Battery system
- OA equipment
- FA equipment
- UPS

G  
5  
P  
Z  
-  
1  
X

### Ordering Information

Contact form	Enclosure rating	Model	Rated coil voltage	Minimum packing unit
SPST-NO (1a)	Flux protection	G5PZ-1A-X	12 VDC 24 VDC	80 pcs./Tray

Note 1. When ordering, add the rated coil voltage to the model number.

Example: G5PZ-1A-X DC12

Rated coil voltage

However, the notation of the coil voltage on the product case as well as on the packing will be marked as □□VDC.

### Ratings

#### Coil

Rated voltage	Item	Rated current (mA)	Coil resistance (Ω)	Must-operate voltage (V)	Must-release voltage (V)	Max. voltage (V)	Power consumption (mW)
				% of rated voltage			
12 VDC		44.1	272	75% max.	5% min.	110% (at 23°C)	Approx. 530
24 VDC		22.1	1087				Approx. 133 *

Note 1. The rated current and coil resistance are measured at a coil temperature of 23°C with a tolerance of ±10%.

Note 2. The operating characteristics are measured at a coil temperature of 23°C.

Note 3. The "Max. voltage" is the maximum voltage that can be applied to the relay coil.

\* Power consumption with Holding Voltage is approx. 133 mW (when applying Holding Voltage at 50%). Please confirm the details on page 4, under ●Coil Voltage Reduction (Holding Voltage) after Relay Operation.

#### Contacts

Item	Connection method	One-contact connection	Two-contact series connection
		Single	
Contact material			
Ag-alloy (Cd free)			
Rated load (Resistive load)		20 A at 200 VDC/ 16 A at 250 VDC	20 A at 400 VDC/ 16 A at 450 VDC
Rated carry current		20 A	
Max. switching voltage		200 VDC 277 VAC	450 VDC
Max. switching current		20 A	

## ■ Characteristics

Item	Connection method	One-contact connection	Two-contact series connection
Contact resistance *1		100 mΩ max.	
Operate time		15 ms max.	
Release time		5 ms max.	
Insulation resistance *2		1,000 MΩ min.	
Dielectric strength	Between coil and contacts	4,000 VAC 50/60 Hz 1 min	
	Between contacts of the same polarity	1,000 VAC 50/60 Hz 1 min	
Impulse withstand voltage	Between coil and contacts	10 kV (1.2 x 50 μs)	
Vibration resistance	Destruction	10 to 55 to 10 Hz, 0.75 mm single amplitude (1.5 mm double amplitude)	
	Malfunction	10 to 55 to 10 Hz, 0.75 mm single amplitude (1.5 mm double amplitude)	
Shock resistance	Destruction	1,000 m/s <sup>2</sup>	
	Malfunction	200 m/s <sup>2</sup>	
Durability	Mechanical	2,000,000 operations min. (at 18,000 operations/h)	
	Electrical (resistive load) *3	10,000 operations at 200 VDC, 20 A 100,000 operations at 200 VDC, 0.25 A 100,000 operations at 250 VAC, 16 A (Switching frequency 1 sec ON-9 sec OFF at 85°C)	10,000 operations at 400 VDC, 20 A 10,000 operations at 450 VDC, 16 A 100,000 operations at 450 VDC, 0.25 A (Switching frequency 1 sec ON-9 sec OFF at 85°C)
Ambient operating temperature		-40 to 85°C (with no icing or condensation)	
Ambient operating humidity		5 to 85%	
Weight		Approx. 15 g	Approx. 15 g x 2 pcs.

Note 1. Values in the table above are the default (ambient temperature 23°C) values.

Note 2. Refer to the *Circuit Diagrams* for the connection method of a two-contact series connection.

Note 3. Refer to *Correct Use* when opening/closing a micro load.

\*1. Measurement conditions: 5 VDC, 1 A, voltage drop method

\*2. Measurement conditions: Measured at the same points as the dielectric strength using a 500 VDC ohmmeter.

\*3. This specification is when diode and zener diode are used. For relay coil, please connect diode and zener diode. For more detail, please refer to ●Connection of Diodes to the Operating Coil on page 4.

## ■ Dimensions

**CAD Data** Please visit our website, which is noted on the last page.

(Unit: mm)

### G5PZ-1A-X

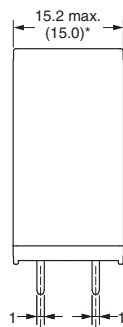
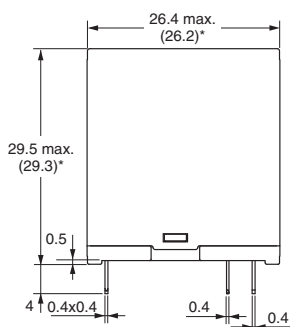

\*Average value

**PCB Mounting Holes**  
(Bottom View)  
Tolerance: ±0.1 mm

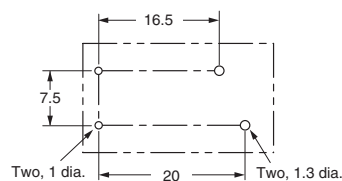

**Terminal Arrangement/  
Internal Connections**  
(Bottom View)

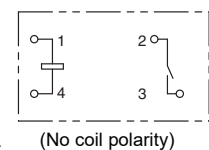

**CAD Data**

## ■ Circuit Diagrams

### ● One-Contact Connection

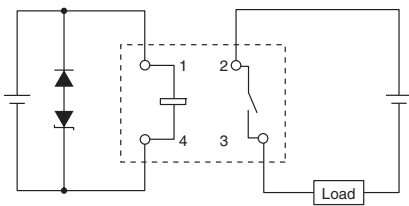

### ● Two-Contact Series Connection

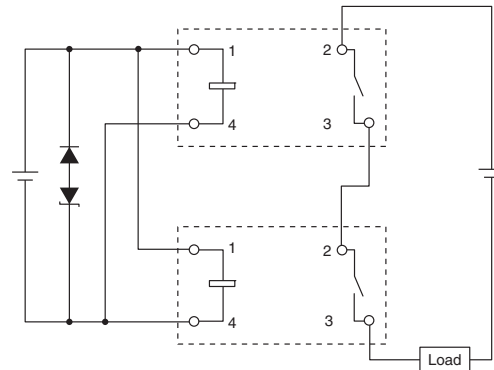

Note. The diode and zener diode are for the absorption of coil surge. (The coil does not have a polarity.)  
The opening/closing part does not have a polarity.

## ■ Approved Standards

The approval rating values for overseas standards are different from the performance values determined individually. Confirm the values before use.

UL Recognized:  (File No. E41515)

Model	Contact form	Coil ratings	Contact ratings	Number of test operations
G5PZ-1A-X	1a (One-contact connection)	12, 24 VDC	20 A, 200 VDC (Resistive) 85°C	10,000
			16 A, 277 VAC (Resistive) 85°C	6,000
	1a (Two-contact series connection)	12, 24 VDC	20 A, 400 VDC (Resistive) 85°C *1	10,000
			16 A, 450 VDC (Resistive) 85°C *1	10,000

\*1. Two-contact series connections only comply with UL standards

EN/IEC, TÜV Certified:  (Certificate No. R50408241)

Model	Contact form	Coil ratings	Contact ratings	Number of test operations
G5PZ-1A-X	1a (One-contact connection)	12, 24 VDC	20 A, 200 VDC (Resistive) 85°C	10,000
			16 A, 277 VAC (Resistive) 85°C	6,000
	1a (Two-contact series connection)	12, 24 VDC	20 A, 400 VDC (Resistive) 85°C	10,000
			16 A, 450 VDC (Resistive) 85°C	10,000

CQC Certified:  (Certificate No. CQC21002317552)

Model	Contact form	Coil ratings	Contact ratings	Number of test operations
G5PZ-1A-X	1a (One-contact connection)	12, 24 VDC	20 A, 200 VDC (Resistive) 85°C	10,000
			16 A, 277 VAC (Resistive) 85°C	6,000
	1a (Two-contact series connection)	12, 24 VDC	20 A, 400 VDC (Resistive) 85°C	10,000
			16 A, 450 VDC (Resistive) 85°C	10,000

Creepage distance (required value)		8 mm min. (IEC/UL)
Clearance (required value)		5.5 mm min. (IEC/UL)
Insulation material group		III a
Type of insulation	coil-contact circuit	Basic (500 V, OV-cat.III, up to 2,000 m above sea level)
	open contact circuit	Micro disconnection
Rated insulation voltage		500 V
Pollution degree		3
Rated voltage system		500 V
Category of protection (IEC61810-1)		RT II
Flammability class (UL94)		V-0
Coil insulation system (UL)		Class F

## ■Precautions

●Please refer to “PCB Relays Common Precautions” for correct use.

### ⚠Warning

As this relay is a high-voltage and high-current type, there is a risk of abnormal heat generation, smoke generation or fire if you use the relay with a contact voltage, current, or for a number of times beyond the specified range. Use only within the specified ranges.



### Correct Use

#### ●Handling

This product has a flux-resistant protection structure. Therefore, do not perform immersible cleaning.

#### ●Coil Voltage Reduction (Holding Voltage) after Relay Operation

- If the coil voltage is reduced to the holding voltage after relay operation, first apply the rated voltage to the coil for at least 100 ms, as shown below.
- A voltage of at least 50% of the rated voltage is required for the coil holding voltage. Do not allow voltage fluctuations to cause the coil holding voltage to fall below this level.

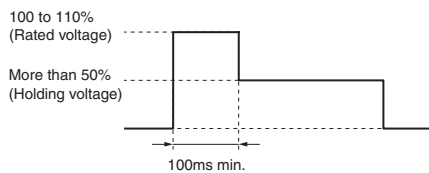

#### ●Connection of Diodes to the Operating Coil

- Connect a diode and zener diode to the relay coil (refer to the following figure).
- The diodes are for coil surge absorption. Switching performance may be affected if only a diode is used, so use in combination with a zener diode.

- The coil has no polarity. Connect the diodes in the reverse polarity of the voltage applied to the coil.
- The recommended zener voltage of the zener diode is one to three times of the coil rated voltage.

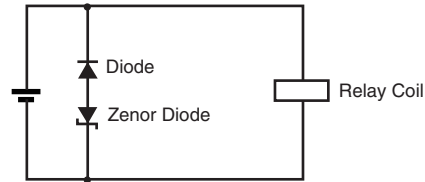

#### ●Relay Service Life

- These relays must be used for high DC voltages. The final failure mode is failure to break the circuit. In a worst-case scenario, burning may extend to surrounding components. Do not use these relays outside of the specified ratings and service life, or for any application other than high DC voltages. Implement safety circuits and other safety measures to minimize the risk in case of the unlikely event of a failure.
- The electrical durability of these relays is specified as the number of load switching operations under a resistive load and OMRON-specified standard testing conditions. The coil drive circuit, ambient environment, switching frequency, or load conditions (e.g., inductive load or capacitor load) may reduce the service life and possibly lead to failure to break. Always confirm the service life in the actual equipment.

#### ●Micro Loads

These power relays are suitable for switching and breaking high-capacity DC. At high-voltage and low-current, breaking characteristics may become unstable. For switching applications at a range between 0.5 A and 2 A, please consult us.

#### ●Installation Intervals

When using a two-contact series connection, ensure an interval of at least 10 mm between the product units.

#### ●Electrical Appliances and Materials Safety Act

The G5PZ-X series does not comply with the Electrical Appliances and Materials Safety Act. Please select our relays carefully in accordance with the application you wish to use the product for.

Please check each region's Terms & Conditions by region website.

## OMRON Corporation

Device & Module Solutions Company

### Regional Contact

#### Americas

<https://components.omron.com/us>

#### Asia-Pacific

<https://components.omron.com/ap>

#### Korea

<https://components.omron.com/kr>

#### Europe

<https://components.omron.com/eu>

#### China

<https://components.omron.com.cn>

#### Japan

<https://components.omron.com/jp>

## X-ON Electronics

Largest Supplier of Electrical and Electronic Components

*Click to view similar products for [General Purpose Relays](#) category:*

*Click to view products by [Omron](#) manufacturer:*

Other Similar products are found below :

[PCN-105D3MH,000](#) [59641F200](#) [5JO-1000CD-SIL](#) [5X827E](#) [5X837F](#) [5X840F](#) [5X842F](#) [5X848E](#) [LY2N-AC120](#) [LY2-US-AC120](#) [M115C60](#)  
[M115N010](#) [M115N0150](#) [603-12D](#) [60HE1-5DC](#) [60HE2S-12DC](#) [61211T0B4](#) [61212T400](#) [61222Q400](#) [61243B600](#) [61243C500](#) [61243Q400](#)  
[61311BOA2](#) [61311BOA6](#) [61311BOA8](#) [61311C0A2](#) [61311COA1](#) [61311COA6](#) [61311F0A2](#) [61311QOA1](#) [61311QOA4](#) [61311T0D6](#)  
[61311TOA6](#) [61311TOA7](#) [61311TOB3](#) [61311TOB4](#) [61311U0A6](#) [61312Q600](#) [61312T400](#) [61312T600](#) [61313U200](#) [61313U400](#) [61322T400](#)  
[61332C400](#) [61343C200](#) [61343C600](#) [61343Q200](#) [61343T100](#) [61343T200](#) [61343T400](#)