

### Quartz Timer Offers Eight Time Ranges, Seven Output Operations

- Field-selectable time ranges from 0.01 second to 9999 hours
- Selectable elapsed time (UP) and time remaining (DOWN) display
- Contact and solid-state outputs available simultaneously
- ON-delay with sustained and adjustable one-shot outputs, with and without continued timing
- Built-in DC power supply for input devices
- Easy-to-read 8 mm-high LED display
- 10-year battery memory back-up available
- Draw-out construction allows setting, servicing without disconnecting wiring
- Panel mounting hardware included



## Ordering Information

### ■ TIMERS

Add the supply voltage to the part number when you order. For example, **H5AN-4DM-AC100-240**.

Timing functions	ON-delay and ON-delay with one-shot		
Contact type	SPDT relay and open collector transistor outputs, both available simultaneously		
Terminal form	14 terminal screws on rear of case		
DC power supply for external components	Provided		Provided
Memory back-up	Not provided		Provided, 10-year built-in battery
<b>Part number</b>	<b>H5AN-4D</b>		<b>H5AN-4DM</b>
Supply voltage	AC	24 V or 100 to 240 V; 50/60 Hz	24 V or 100 to 240 V; 50/60 Hz
	DC	12 to 24 V, 48 V or 100 V	12 to 24 V

### ■ REPLACEMENT PARTS

Description	Part number
Plastic front cover	H5AN COVER 0377762-0
Mounting bracket (one pair supplied with each timer); order two	Y92H-5

# Specifications

Part number		H5AN-4D	H5AN-4DM
Supply voltage	AC	24 V or 100 to 240 V; 50/60 Hz	24 V or 100 to 240 V; 50/60 Hz
	DC	12 to 24 V, 48 V or 100 V (permissible ripple factor: 20% max.)	12 to 24 V (permissible ripple factor: 20% max.)
Operating voltage		85 to 100% of rated voltage	
Power consumption	AC	10 VA at 240 VAC, 50 Hz	
	DC	5 W at 24 VDC	
Internal power supply for external components		12 VDC $\pm$ 10%, 80 mA (permissible ripple factor: 5% max.)	
Timing functions		ON-delay and ON-delay with one-slot	
Reset and Gate inputs		No-voltage	
Control output	Type	SPDT relay and open collector solid-state output	
	Time limit	Instantaneous	
	Max. load	3 A, 250 VAC (p.f. = 1) for relay; 100 mA max., 30 VDC for open collector output	
	Min. load	10 mA, 5 VDC	
Repeat accuracy		$\pm$ 0.01% $\pm$ 0.05 sec max. (power-OFF start); $\pm$ 0.005% $\pm$ 0.03 sec max. (reset start)	
Setting error		See "Repeat Accuracy"	
Resetting system		Power-OFF, manual or external	Manual or external
Resetting time		Power-OFF: 0.5 sec min.; External: 0.02 sec signal minimum	
Indicators		Time Up (red LED), Reset Input (red LED); 8 mm LED numeric display	
Materials		Plastic	
Mounting		Panel; two mounting brackets included	
Connections		Back-mounted screw terminals	
Weight		360 g (12.7 oz.)	
Approvals		UL/CSA/SEV	
Operating ambient temperature		-10° to 55°C (14° to 131°F)	
Humidity		35 to 85% RH	
Vibration	Mechanical durability	10 to 55 Hz; 0.75 mm (0.03 in) double amplitude	
	Malfunction durability	10 to 55 Hz; 0.5 mm (0.02 in) double amplitude	
Shock	Mechanical durability	30 G	
	Malfunction durability	10 G	
Variation due to voltage change		See "Repeat Accuracy"	
Variation due to temperature change		See "Repeat Accuracy"	
Insulation resistance		100 M $\Omega$ min. at 500 VDC	
Dielectric strength		2,000 VAC, 50/60 Hz for 1 minute between current-carrying terminals and non-current-carrying metal parts 750 VAC, 50/60 Hz for 1 minute between non-continuous contacts	
Service life	Mechanical	10 million operations minimum	
	Electrical	100,000 operations minimum at maximum rating	

# Engineering Data

## ■ ELECTRICAL SERVICE LIFE

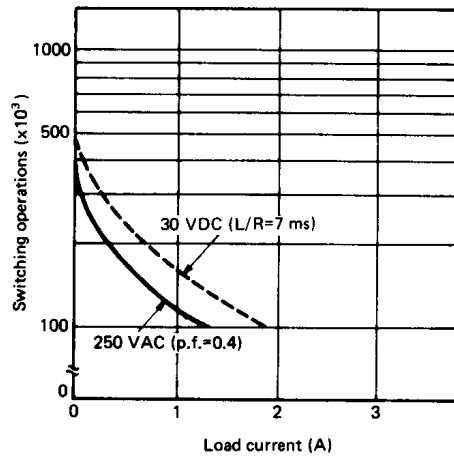
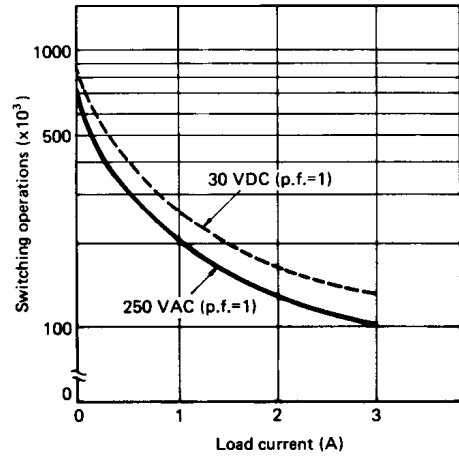

## Timing Charts

### ■ ELAPSED TIME (UP) DISPLAY

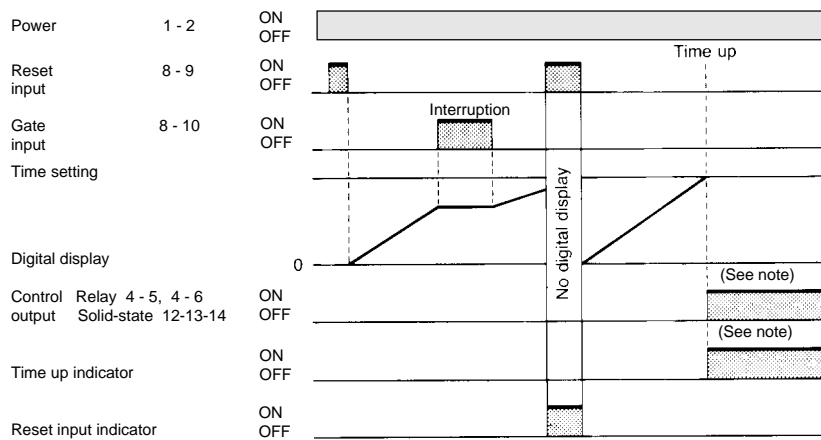

**NOTE:** After the set time has elapsed, operation continues according to the mode selected.

### ■ TIME REMAINING (DOWN) DISPLAY

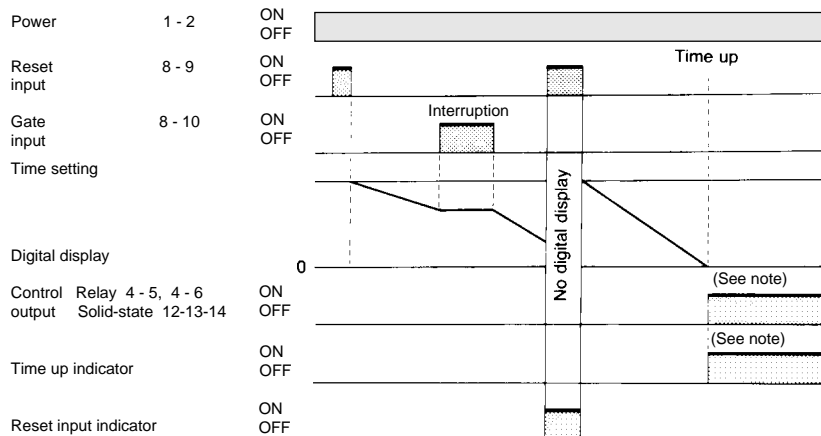

**NOTE:** After the set time has elapsed, operation continues according to the mode selected.

■ OPERATION MODES

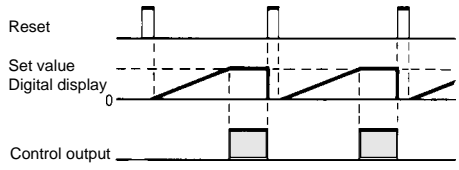
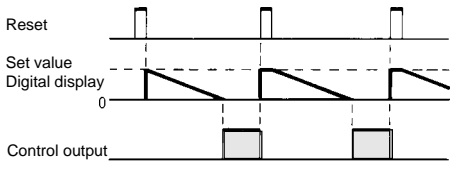
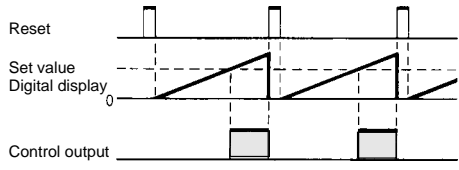
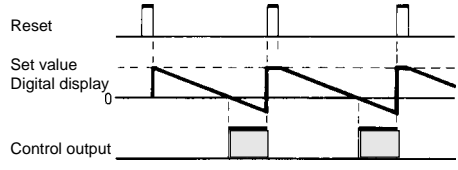
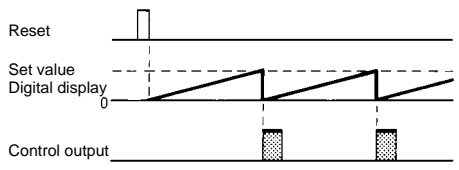
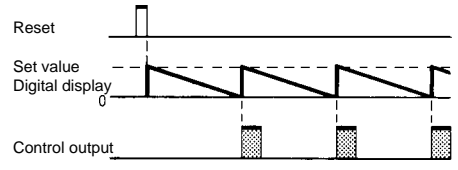
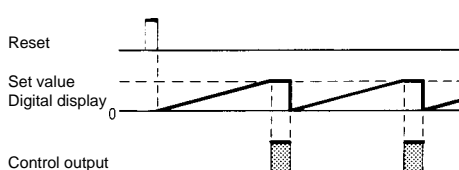
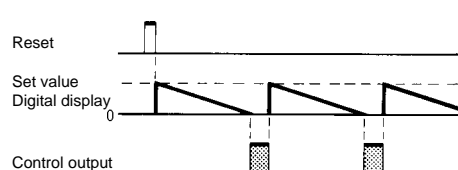
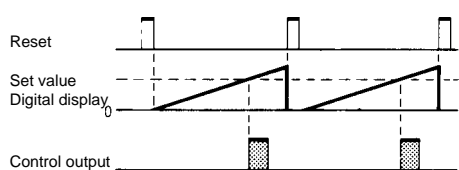
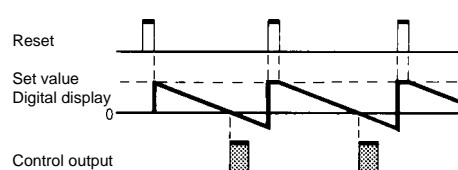
Mode	Elapsed time (UP) display	Time remaining (DOWN) display
<p><b>N</b> Sustained output</p>	 <p>The display increments from zero to the preset. When the preset is reached, the output is energized. The preset is display until the timer is reset.</p>	 <p>The display decrements from the preset to zero. When zero is reached, the output is energized. Zeros are displayed until the timer is reset.</p>
<p><b>F</b> Sustained Output</p>	 <p>The display increments from zero to the preset. When the preset is reached, the output is energized. The display will continue to increment until the timer is reset.</p>	 <p>The display decrements from the preset to zero. When zero is reached, the output is energized. The display will continue to decrement until the timer is reset.</p>
<p><b>C</b> One-shot Output</p>	 <p>The display increments from zero to the preset. When the preset is reached, the timer restarts its timing from zero and energizes a one-shot output. The cycle is repeated until the timer is reset.</p>	 <p>The display decrements from the preset to zero. When zero is reached, the timer restarts its timing from the preset and energizes a one-shot output. The cycle is repeated until the timer is reset.</p>
<p><b>R</b> One-shot Output</p>	 <p>The display increments from zero to the preset. When the preset is reached, the output is energized for the one-shot time. Timing from zero is restarted at the trailing edge of the output. The cycle is repeated until the timer is reset.</p>	 <p>The display decrements from the preset to zero. When zero is reached, the output is energized for the one-shot time. Timing from the preset is restarted at the trailing edge of the output. The cycle is repeated until the timer is reset.</p>
<p><b>K</b> One-shot Output</p>	 <p>The display increments from zero to the preset. When the preset is reached, the output is energized for the one-shot time. The display continues to increment until the timer is reset.</p>	 <p>The display decrements from the preset to zero. When zero is reached, the output is energized for the one-shot time. The display continues to decrement until the timer is reset.</p>

**NOTE:** In modes F and K, when the 99 min 59 s or 99 h 59 min ranges are selected in DOWN display, the overflow values will be shown as 9959, 9958, 9957, etc.

In C mode, the set time should be longer than the one-shot time.

OPERATION MODES (continued)

Mode	Elapsed time (UP) display	Time remaining (DOWN) display
<b>P</b> One-shot output	<p>The display increments from zero to the preset. When the preset is reached, the output is energized for the one-shot time. The timer restarts its timing, but the display is not updated until the one-shot time is up. The cycle is repeated.</p>	<p>The display decrements from the preset to zero. When zero is reached, the output is energized for the one-shot time. The timer restarts its timing, but the display is not updated until the one-shot time is up. The cycle is repeated.</p>
<b>Q</b> One-shot Output	<p>The display increments from zero to the preset. When the preset is reached, the output is energized for the one-shot time. The display continues incrementing during the one-shot, but restarts from zero when the one-shot time is up. The cycle is repeated.</p>	<p>The display decrements from the preset to zero. When zero is reached, the output is energized for the one-shot time. The display continues decrementing during the one-shot, but restarts from the preset when the one-shot time is up. The cycle is repeated.</p>

**NOTE:** In mode Q, when the 99 min 59 s or 99 h 59 min ranges are selected in DOWN display, the overflow values will be shown as 9959, 9958, 9957, etc.

In P mode, the set time should be longer than the one-shot time.

Dimensions

Unit: mm (inch)

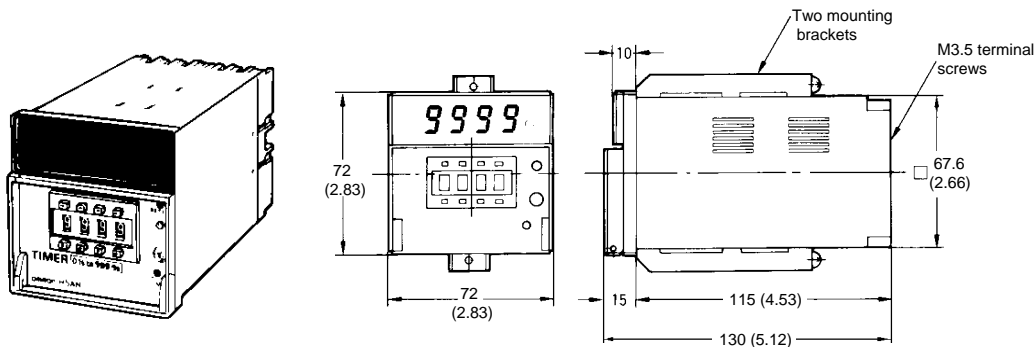

Panel cutout

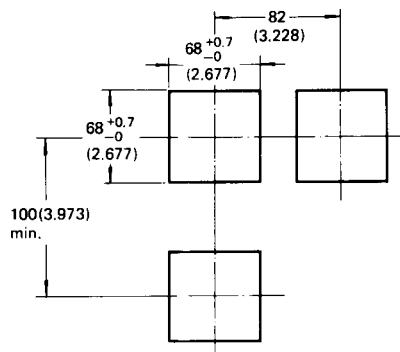

Panel cutout for side-by-side mounting for two units

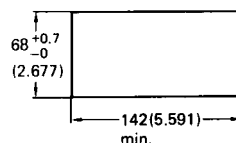

**NOTE:** Recommended panel thickness is 1 to 5 mm. Panel cutout conforms to DIN 43700.

# Connections

## Input terminal number (no-voltage only)

COM	Reset	Gate
8	9	10

## Power supply terminal numbers

AC (common), DC-	AC (hot), DC+	Ground
1	2	3

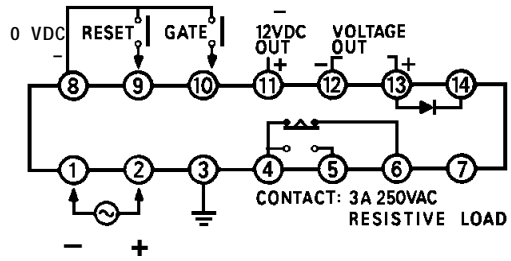

## Output terminal numbers

Contact		
COM	NO	NC
4	5	6
Solid-state		
COM	Load	Surge absorber
12	13	14

## Power supply for externally connected equipment

Voltage supply	DC-	DC+
12 VDC, 80 mA	8	11

## POWER SUPPLY CONNECTION

Connect the required supply voltage to terminals 1 and 2. In environments with external noise, connect ground terminal 3 at a resistance of less than 100Ω.

### AC power supply

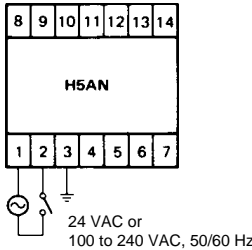

### DC power supply

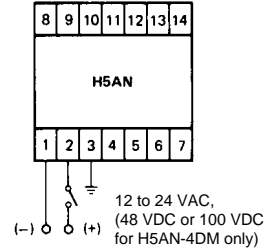

## LOAD CONNECTION

Terminals 4, 5 and 6 are for contact output. Terminals 12 and 13 are for solid-state output. Terminal 14 is a surge absorber for use when an inductive load is connected.

### Load Operation

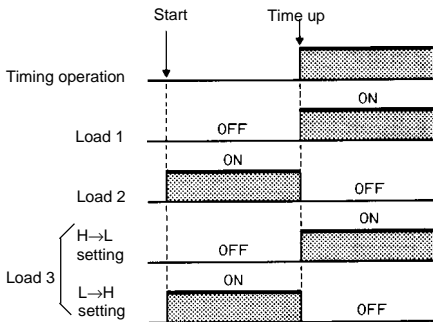

### Contact output

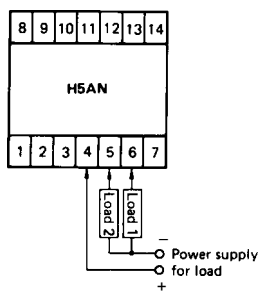

### Solid-state output

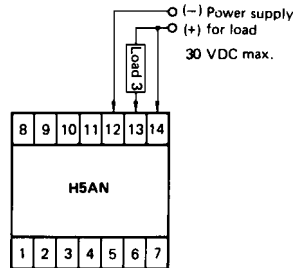

High and low output levels are selected by internal switch. See "Operations" section for setting information.

■ RESET AND GATE INPUTS

Reset input

Use a no-voltage contact or open collector type transistor between terminals 8 and 9. The timer resets when contact is made or when the transistor is ON.

Gate input

Use a no-voltage contact or open collector type transistor between terminals 8 and 10. The timer stops when the contact makes or when the transistor is ON. When the gate signal opens, timing resumes at the point of interruption. Use a contact with minimum contact bounce (chatter), otherwise the bounce time will cause an error in the timer's operating time.

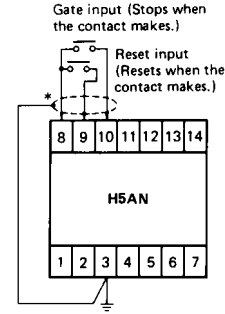

Input signal requirements

Contact input

Resistance	1 kΩ max.
Residual voltage	1 V max. when the contact makes
Contact material	Gold-plated contacts recommended

Solid-state input

Input type	Open collector transistor
Voltage when collector is OFF	20 V min.
Saturated voltage when transistor is ON	3 V max.
Collector current	50 mA min.
Input current between collector and base	0.5 μA max.

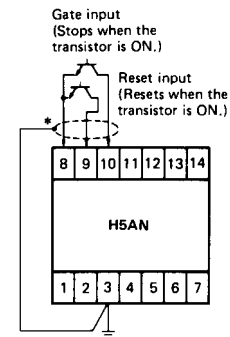

Solid-state inputs (NPN)

When connecting a solid-state circuit not of the open collector type to the gate or reset inputs as shown in the figure below, the voltage of the solid-state circuit (+ V) should be 13 to 30 V, and the  $V_{CE(S)}$  of the transistor should be less than 3 V (the

current that flows from either terminal 9 or 10 is approximately 10 mA). Moreover, it is essential that the circuit be ON for gate or reset input, and OFF when there is no input.

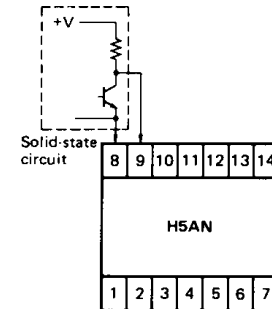

■ POWER SUPPLY FOR EXTERNALLY-CONNECTED COMPONENTS

The H5AN has a built-in power supply for externally connected components such as sensors for gate or reset input, or loads connected to the solid-state control output (12 VDC, 80 mA).

Power can be applied to the sensors and loads simultaneously.

Gate or Reset input

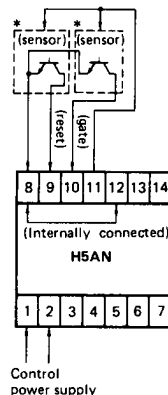

Solid-state output load

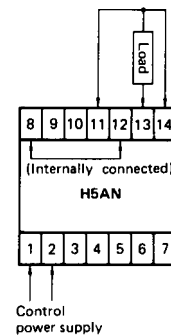

■ SIMULTANEOUS INPUT TO SEVERAL H5AN TIMERS

A single contact or open collector type transistor can be used to apply the gate or reset input to two or more H5AN timers. Caution is required because a large current flows into the transistor. The current that flows from H5AN is approximately 10 mA per unit.

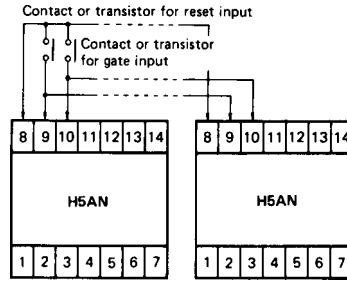

Operation

■ NOMENCLATURE

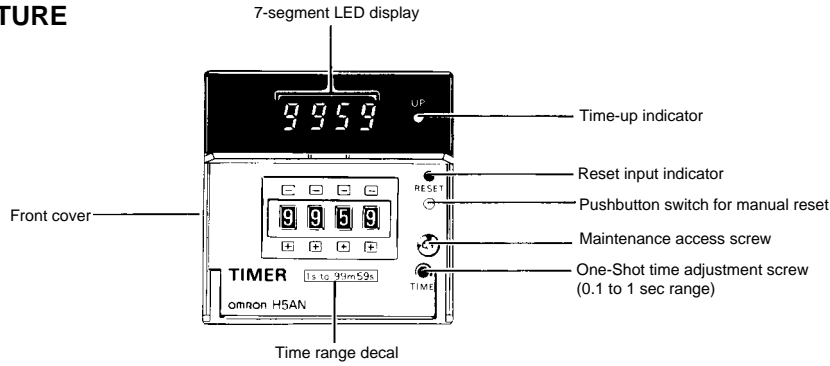

■ ACCESS TO SELECTOR SWITCHES

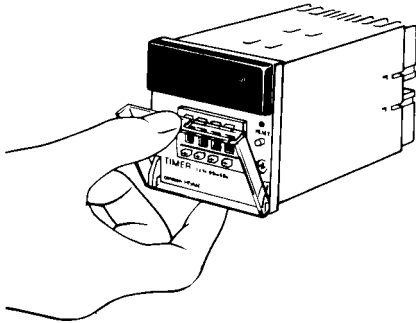

Open the front cover. Use a Phillips screwdriver to gain access to internal parts. As the maintenance access screw is turned, the internal mechanism draws out. Pull out the timer from its case to set internal switches to desired settings.

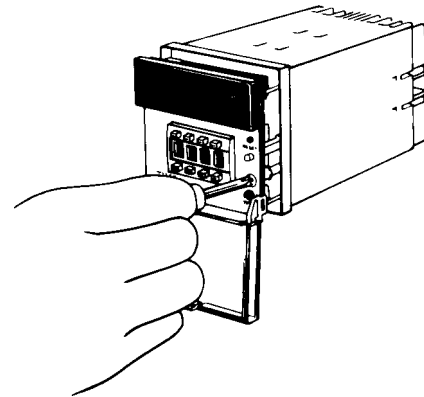



### PROGRAMMING H5AN SPECIFICATIONS

Internal selector switches are used for programming elapsed time (UP) or time remaining (DOWN) display, time range, operation mode and solid-state output level.

Manual reset (front panel) enable switch

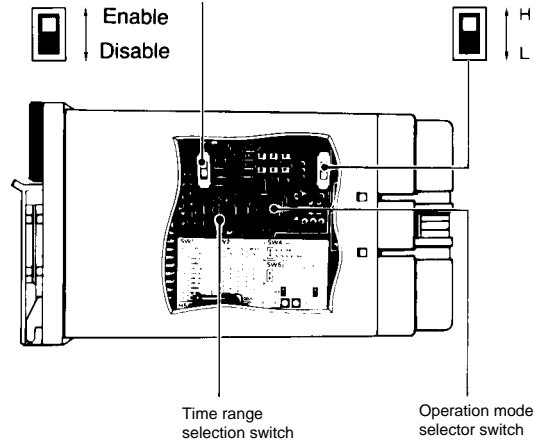

Solid-state output level selector switch  
 H Changed "low" to "high" when time is up  
 L Changed "high" to "low" when time is up

#### Time range selector settings

Switch position	Time range
0	0.01 to 99.99 s
1	0.1 to 999.9 s
2	1 to 9999 s
3	1 s to 99 min 59 s
4	0.1 to 999.9 min
5	1 min to 99 h 59 min
6	0.1 to 999.9 h
7	1 to 9999 h
8	same as "0"
9	same as "1"

#### Operation mode selector

Switch position	Operation Mode	Display mode
0	N	Time remaining (DOWN) display
1	F	
2	C	
3	R	
4	K	
5	P	
6	Q	
7	(same as 0)	Elapsed time (UP) display
8	N	
9	F	
A	C	
B	R	
C	K	
D	P	
E	Q	
F	(same as 8)	

### SETTING TIME PRESET

Use the four pushwheel switches on the front panel to set the desired time. The H5AN timer does not display the decimal point in ranges for 99.99 sec, 999.9 sec, 999.9 min or 999.9 hr. Firmly push the switches to avoid having two numbers appear in the display window. This causes the operating time to drift widely.

In the 99 hr 59 min and 99 min 59 sec ranges, the second digit from the right cannot be more than 5. Even if the digit is set to 6, 7, 8 or 9, the setting will be interpreted as 5.

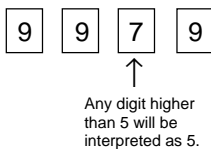

#### Undesirable setting

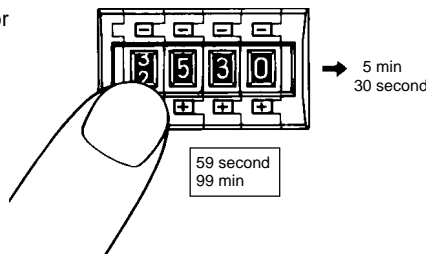

#### Warning

Do not set all four digits to zero. This causes a momentary output to occur that may lead to accidental injury or damage.

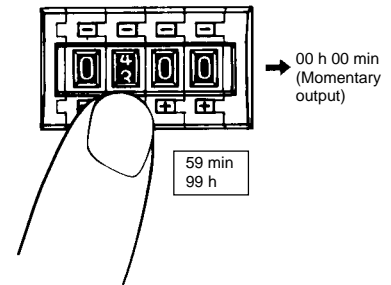

### SETTING ONE-SHOT TIME

Output modes C, R, K, P and Q provide a one-shot output. Be sure to set the one-shot value, between 0.1 and 1 second, using the potentiometer in the lower right corner of the front panel.

## ■ PROGRAMMING CONSIDERATIONS FOR TIMERS WITH MEMORY PROTECTION

For units with memory protection, it is necessary to reset (either externally or manually) the timer at the time the power is applied. If the timer is not reset, it operates in accordance with the previous data. Also reset the timer after any changes are made to the internal switches.

## ■ RECOVERY FROM A POWER FAILURE

### H5AN-4D

The duration of the power failure determines how the timer acts when power is restored.

With a power failure of less than 0.01 second duration, the timer resumes timing from the point of interruption upon recovering power.

Length of power failure	Action when power is restored
0.01 sec or less	Timer resumes timing and does not reset
0.01 sec to 0.5 sec	Timer either resets or resumes timing
0.5 sec or more	Timer resets

### H5AN-4DM

This timer has a battery backed memory to protect settings against power failure. When a power failure occurs, the timing operation is interrupted. When power returns, the timer continues from the point of interruption.

The back-up battery will retain data for up to 10 years. However, the battery may not be replaced.

**NOTE: ALL DIMENSIONS ARE IN MILLIMETERS. To convert millimeters into inches divide by 25.4.**

# OMRON

## OMRON ELECTRONICS, INC.

One East Commerce Drive  
Schaumburg, IL 60173

**1-800-55-OMRON**

## OMRON CANADA, INC.

885 Milner Avenue  
Scarborough, Ontario M1B 5V8

**416-286-6465**

## X-ON Electronics

Largest Supplier of Electrical and Electronic Components

*Click to view similar products for [Timers](#) category:*

*Click to view products by [Omron](#) manufacturer:*

Other Similar products are found below :

[79237785](#) [H5AN-4DM DC12-24](#) [H5CN-YAN AC100-240](#) [H5CX-L8S-N AC100-240](#) [H5AN-4D DC12-24](#) [THR2U-110A](#) [81506944](#)  
[88225029](#) [H5S-YB4-X](#) [H7AN-2D DC12-24](#) [H5CN-XANS DC12-48](#) [H7AN-W4DM DC12-24](#) [H7AN-4DM DC12-24](#) [H7AN-4D DC12-24](#)  
[H7AN-RT6M AC100-240](#) [600DT-CU](#) [7PV1513-1AP30](#) [7PV1538-1AW30](#) [1SVR508100R0000](#) [1SVR550127R4100](#) [1SVR550212R4100](#)  
[1SVR730010R3200](#) [1SVR730020R3300](#) [1SVR730120R3100](#) [1SVR730180R3100](#) [1SVR730211R2300](#) [PCU-511UNI](#) [H3C-R](#) [H3CR-A8-301](#)  
[24-48AC/12-48DC](#) [H3CR-A8E 24-48AC/DC](#) [H3CR-F8 100-240AC/100-125DC](#) [H3CR-FN 100-240AC/100-125DC](#) [H3DK-G 24-230AC/DC](#)  
[H3DK-HBL AC/DC24-48](#) [H3DK-M1A DC12](#) [LT4H-AC24V](#) [LT4HW8-AC240V](#) [LT4HW-AC240V](#) [LT4HW-AC24VS](#) [31L48AP](#)  
[31L48TPM240](#) [RC302](#) [RC312](#) [REV-201M](#) [RG](#) [AT78041](#) [AT78051](#) [ATC180041](#) [TMM1](#) [TMP](#)