

1/4 DIN Size Timer Features Prompted Programming and Large LCD Display

- 24 hours x 7 days programming using just 5 switches
- 16 program steps and cycle operation
- Two independent 15 A control circuits
- Manual override switch for each output
- Easy-to-read, large, 0.5 inch high LCD display
- Wide operating voltage range
- 10-year battery backup for memory protection
- Hardware for panel and surface mounting included; designed for track mounting
- Protective cover and mounting track may be ordered separately



Ordering Information

■ TIMERS

Part number	H5L-A
Supply voltage	100 to 240 VAC, 50/60 Hz
Timing function	Weekly timer, 24 hours x 7 days, ON and OFF programming
Contact type	Two SPST time limit contacts with manual override switches
Terminal form	Screw terminals accessible from front and back

■ TIME RANGES

Time setting range	00:00 to 23:59 (hours:minutes)
Program capacity	16 steps: ON = 1 step, OFF = 1 step, CYCLE = 4 steps
Cycle length	1 minute to 23 hours 59 minutes
Minimum cycle interval	1 minute between OFF and ON periods

■ ACCESSORIES

Description		Part number
Hard plastic cover		Y92A-96A
Mounting track	50 cm (1.64 ft) length	PFP-50N
	1 m (3.28 ft) length	PFP-100N
	End plate	PFP-M

■ REPLACEMENT PARTS

Description	Part number
Surface mounting bracket; one supplied with each H5L timer	H5L 2433983-6
Flush mounting bracket; one supplied with each H5L timer	H5L 2433982-8

Specifications

Part number		H5L-A	
Supply voltage	AC	100 to 240 V, 50/60 Hz	
	DC	-	
Operating voltage		85 to 110% of rated voltage	
Power consumption		7 VA	
Timing functions		24 hours x 7 days, ON and OFF programming 16 steps; ON = 1 step, OFF = 1 step, CYCLE = 4 steps	
Control output	Type	Time limit	Two independent SPST relays
		Instantaneous	-
	Max. load		10 A at 250 VAC, 15 A at 125 VAC, 10 A at 30 VDC (resistive load at 25°C (77°F))
	Min. load		100 mA, 5 VDC
Repeat accuracy		±0.01%, ±0.05 sec maximum	
Long-term error		±15 seconds per month at 25°C (77°F)	
Setting error		Included in "Repeat accuracy"	
Indicators		LCD display: day, date, time, output status; 12.5 mm (0.05 in) high	
Materials		Plastic	
Mounting		Panel, track or surface; mounting brackets included	
Connections		Front and rear connections, screw terminals	
Weight		350 g (12.4 oz.)	
Approvals		UL/CSA/SEV	
Operating ambient temperature		-10° to 55°C (14° to 131°F)	
Humidity		35 to 85% RH	
Vibration	Mechanical durability		10 to 55 Hz; 0.75 mm (0.03 in) double amplitude
	Malfunction durability		10 to 55 Hz; 0.5 mm (0.2 in) double amplitude
Shock	Mechanical durability		30 G
	Malfunction durability		10 G
Variation due to voltage change		Included in "Repeat accuracy"	
Variation due to temperature change		Included in "Repeat accuracy"	
Insulation resistance		10 MΩ at 500 VDC minimum	
Dielectric strength		2,000 VAC, 50/60 Hz for 1 minute across current-carrying terminals and exposed non-current-carrying metallic parts. 1,000 VAC, 50/60 Hz for 1 minute across control power supply circuit and contact control output circuit and across non-continuous contacts.	
Service life		100,000 operations minimum (resistive load, 15 A at 250 VAC)	

Engineering Data

■ AMBIENT OPERATING TEMPERATURE AND CARRY CURRENT

The upper limit of the ambient operating temperature must be derated when a large carry current is being applied. This case occurs when both circuits are energized simultaneously.

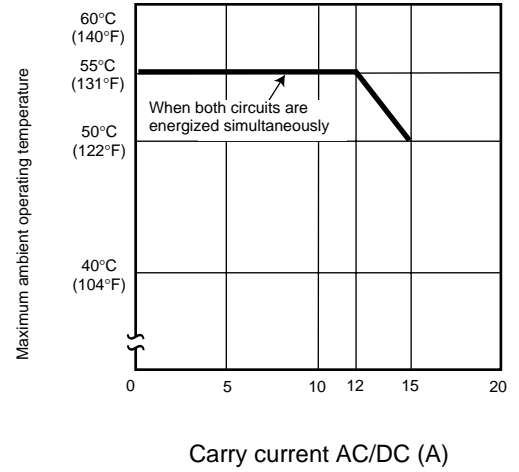

Dimensions

Unit: mm (inch)

■ TIMER

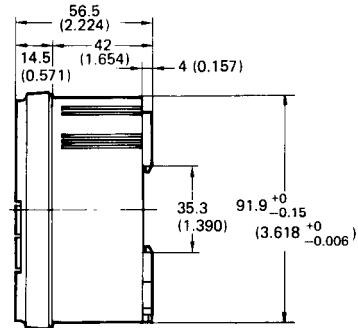
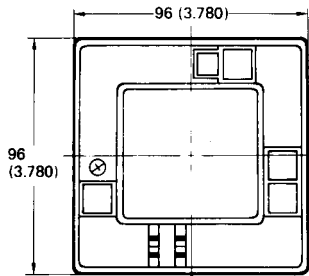
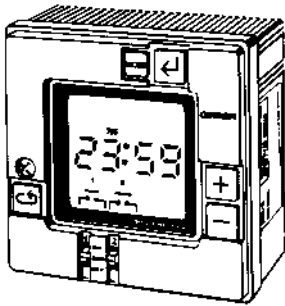

■ PROTECTIVE COVER

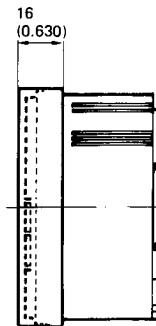
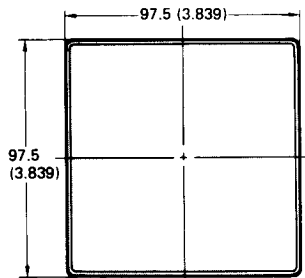
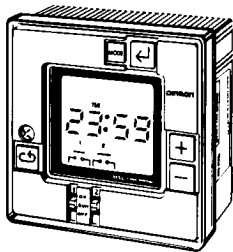

The hard plastic cover prevents accidental resetting. It also shields the front panel from dirt and water. The cover is intended for use in areas where unusual service conditions do not exist.

■ MOUNTING TRACK AND ACCESSORIES

PPF-100N/PPF-50N DIN Rail

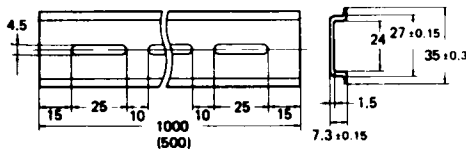

PPF-M End Plate

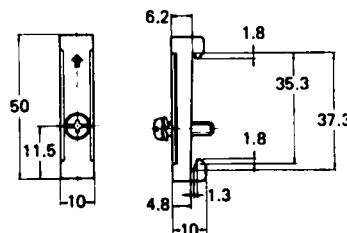

PPF-S Spacer

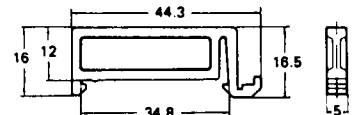

Connections

Power supply terminal numbers		Output terminal numbers	
AC (common)	AC (hot)	Load 1	Load 2
2	1	7 and 8	5 and 6

If operating conditions exceed the noise values at right, connect a surge absorber to prevent malfunction or damage to the timer. This is especially important when inductive loads are being switched by the timer.

Noise voltage: 2 KV
 Pulse width: 100 ns
 Rise time: 1 ns

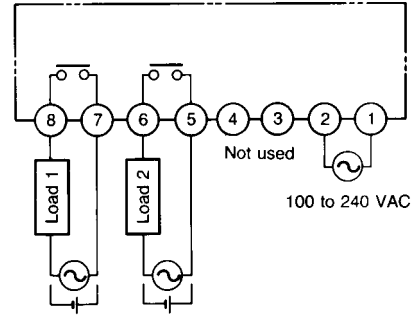

Installation

WIRING

Power Supply

For panel mounting

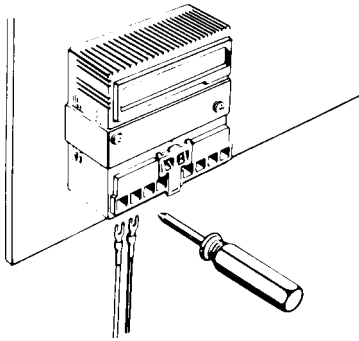

Wire the H5L timer from the rear once the unit is mounted in the panel.

For track and surface mounting

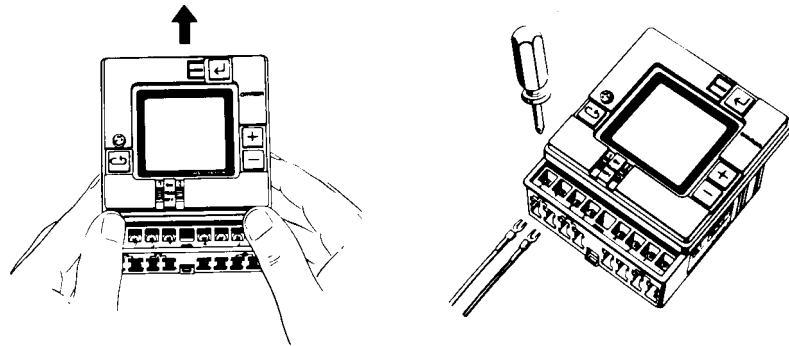

- Wire the H5L timer from the front when the unit is track or surface mounted.
1. Loosen the screw above the "cycle" key on the left front.
 2. Slide the upper part of the housing upward about 15 mm (0.59 in).
 3. Step 2 exposes the terminals. Perform the wiring.
 4. Slide the upper part of the housing to the original position, then tighten the screw.

Output Circuits

Perform wiring so that the potential across the output contacts is the same. This prevents short-circuiting of the contacts. Refer to the connections chart above for terminal numbers.

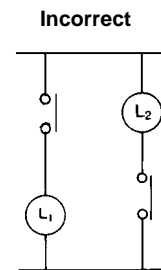
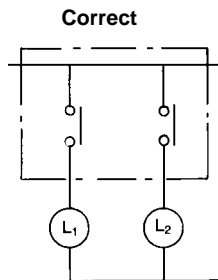

Operation

■ NOMENCLATURE

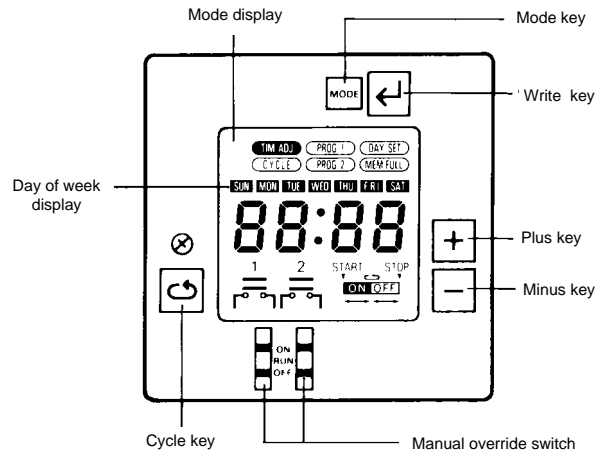

Output status indication

Output ON



Output OFF



Invalid instruction written to a step



■ KEY OPERATIONS

Key	Name	Function
	Mode key	Changes program mode
	Write key	To write the set data using the plus and/or minus key Reads out the set program
	Plus key	Plus key increments displayed digits
	Minus key	Minus key decrements displayed digits When the plus key is held down, the displayed digit increments continuously; when the minus key is held down, the displayed digit decrements continuously When specifying output, the plus key specifies output ON, the minus key specifies output OFF. If the same key is pressed twice, the output specification becomes invalid, so neither ON nor OFF is set.
	Cycle key	Selects the cycle program.
	Manual override switch	ON: Turns ON output regardless of program RUN: Executes program OFF: Turns OFF output regardless of program Each circuit can be operated independently

PROGRAMMING SEQUENCE

The H5L weekly timer has six program modes. Use the mode key to change the modes. Use the write key, plus and minus keys and cycle key for programming in each mode.

Mode sequence

Programming details

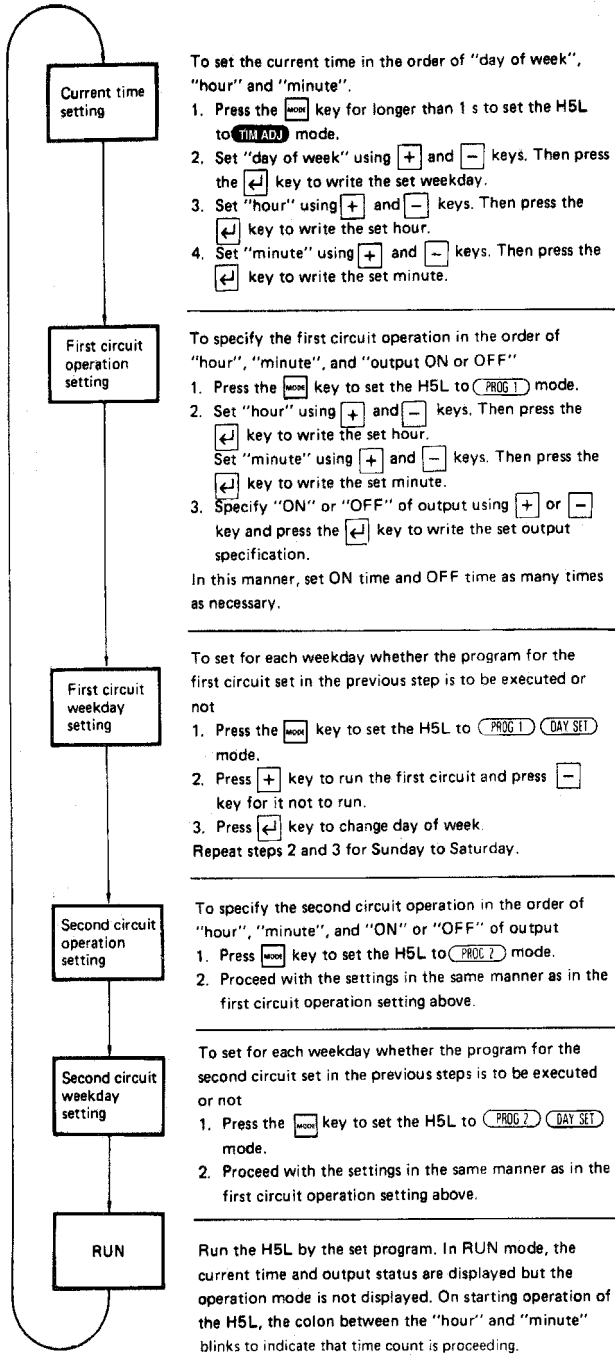

NOTE: The H5L operates according to the program already set, even while another program is being set. The output status display shows the program being set. The actual output status may not agree with the displayed status during programming.

Cycle program

The cycle program in H5L can be used to repeat ON and OFF output patterns for a length of time. A cycle program consists of four steps: Start time, ON time, OFF time and Stop time.

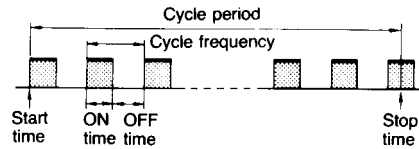

Setting Cycle Program

Set the cycle program with the following four steps:

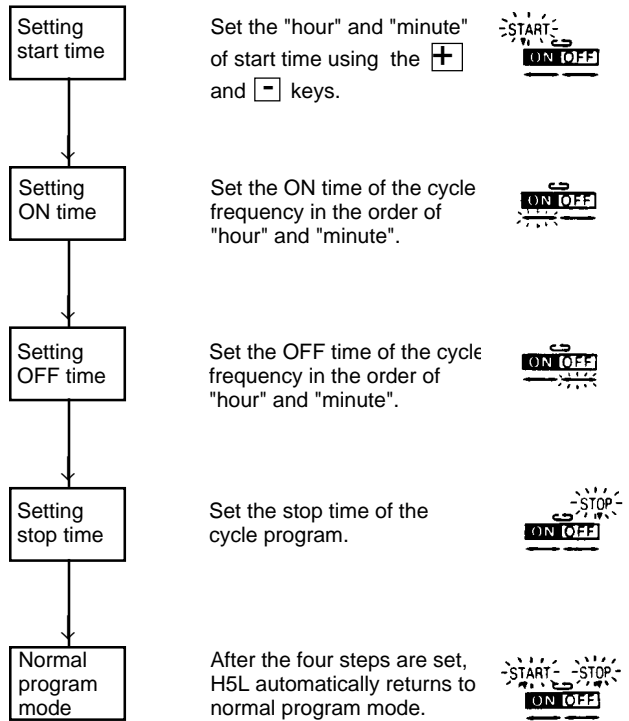

Cautions on Using Cycle Programs

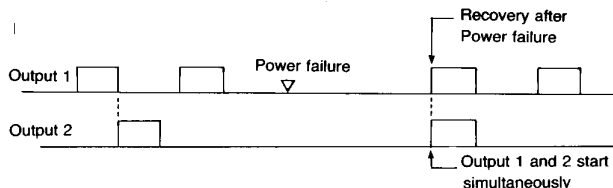

1. When the current time is included within the set cycle period, the cycle operation starts (output turns ON) on completing the cycle program setting (when stop time is written).
2. When any of the following occurs during a cycle period, the cycle operation **restarts from output ON**:
 - Recovery after power failure
 - Current time adjustment
 - Change of start or stop time of the cycle program during operation

For this reason, if the cycle program is set in such a manner that outputs 1 and 2 have a phase difference, as shown below, the **phase difference is changed automatically** when any of the abovementioned conditions occur. We recommend using cycle programs sequentially.



3. The cycle period (from start time to stop time) must not be a multiple of the cycle frequency (ON time plus OFF time). The cycle period can be set between 1 minute and 24 hours.
4. ON time as well as OFF time can be set within a range of 1 minute to 23 hours 59 minutes.

■ DELETING ON/OFF PROGRAM STEPS

Use the MODE and WRITE keys to advance to the output status indicator of the steps to be deleted. Use the  and  keys to make the output status indicator invalid (no bar). Press the WRITE key and the step is deleted.

■ DELETING CYCLE PROGRAM STEPS

Use the MODE and WRITE keys to advance to the first step of the cycle program. Push the CYCLE key followed by the WRITE key. All four steps of the cycle program are deleted.

■ CLEARING THE PROGRAM

The H5L cannot be cleared by cycling the power OFF/ON since a built-in battery protects the memory. In order to clear the contents of the memory, follow these steps.

1. Loosen the screw above the cycle key on the left side of timer front, then slide the front panel up.
2. Turn the timer over and depress the metal strip at the top near the area of the small hole.
3. The contents of the memory are cleared and the display will show all of the graphics for approximately 5 seconds. This may be used for a quick visual check.

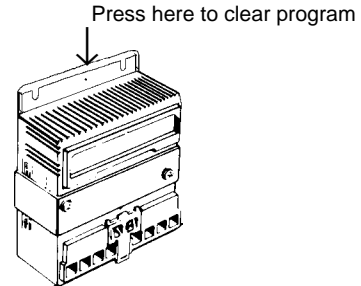

CAUTION: Use the front panel override switches to control the status of the outputs when clearing the program. This maintains the desired functions without interruption.

Programming Example

■ CREATE A TIMING CHART BEFORE PROGRAMMING

Always create a timing chart before programming the timer. The hardcopy provides an excellent tool if troubleshooting is needed. If changes to the programming are necessary, having the hardcopy will make the job easier.

The timer will generate outputs during programming depending on the logic of the current or previous program. Use the output override switches to manually control the outputs if this is undesirable.

Sample Timing Chart Blank

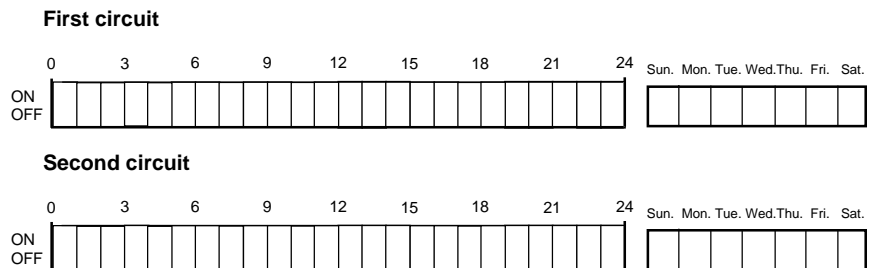

■ SETTING ON AND OFF PROGRAMS, CYCLE PROGRAMS

In this example, the first circuit is programmed to turn ON at 7:40 and OFF at 19:30. This circuit is operated from Monday through Friday and stopped on Saturday and Sunday.

The second circuit is cyclically operated with each parameter set as follows:

Start time: 6:50
 ON time: 5 minutes
 OFF time: 20 minutes
 Stop time: 20:30

The second circuit is stopped from operating on Sunday and operated from Monday through Saturday. The current time is assumed to be 11:15 a.m. on Tuesday.

Creating Timing Chart

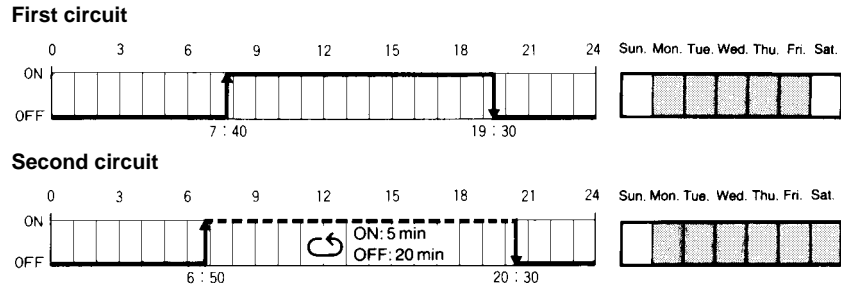

Writing the Program

Setting the current time

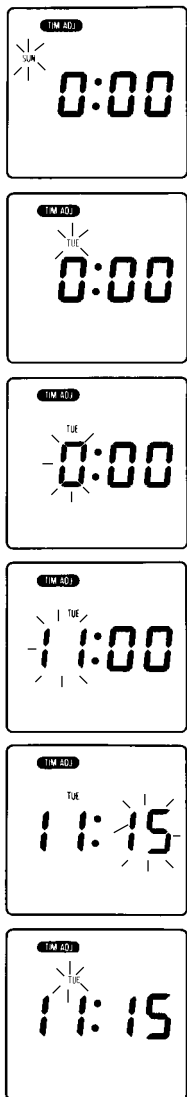

To set the current time, "day of the week", "hour", and "minute" must be specified. First, turn on the power to the H5L. Press the **Mode** key for more than 1 sec. The TIM ADJ indicator is displayed. Set 11:15 on Tuesday, the current time in example1.

Start with setting the day of the week. The blinking indicator indicates the parameter that can be set. Set the current day of the week to Tuesday by pressing the + or – key.

When "TUE" is displayed, press the **Write** key to store the current day of the week in memory. Then the "hour" indicator will flash at this time and the "day of the week" indicator will stop blinking.

Set the current hour to 11 by pressing the + or – key, followed by the **Write** key.

At this time, the "minute" indicator will blink. Set the current minute to 15 by pressing the + key or – key, followed by the **Write** key.

This completes the current time setting.

Next, program the first circuit's operation.

First Circuit Operation Setting

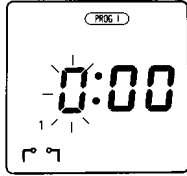

To program the operation of the first circuit, "hour", "minute", and "output" must be specified.

Press the **MODE** key to set the H5L in PROG 1 mode. The display will be as shown on the left.

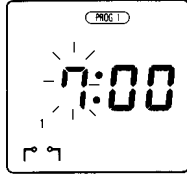

Since the first circuit is turned ON at 7:40, set the "hour" to 7 by pressing the + or – key and then store it in memory by using the **Write** key.

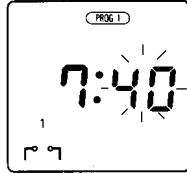

Then "minute" will start blinking. Set it to 40 by using the + or – key and store it in memory by pressing the **Write** key.

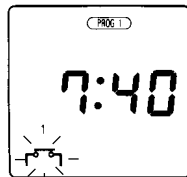

Now, the output status indicator will blink. Set the output to the ON status with the + key followed by the **Write** key.

(If the + key is pressed twice at this time, the display will give an invalid indication (). Then if the **Write** key is pressed, this program will be deleted.)

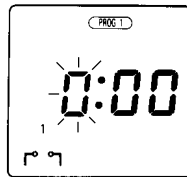

The display returns to the initial status as shown on the left and waits for the next program step to be input.

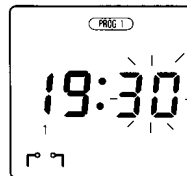

Since the first circuit should be turned OFF at 19:30, set the hour to 19 and the minute to 30 by using the + or – key and then the **Write** key.

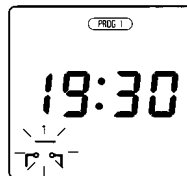

Now the output status indicator starts blinking. Set the output to OFF status by the – key and store it in memory by the **Write** key.

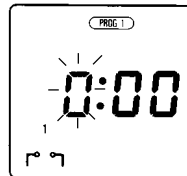

The display returns to the initial status and waits for the next program step to be input. As the first circuit operation setting is completed, let us turn to setting the "day of the week".

Second Circuit Operation Setting

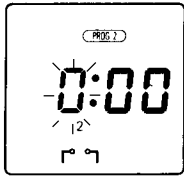

Press the **MODE** key to set the H5L in PROG 2 mode. The display appears as shown on the left.

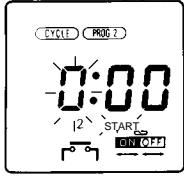

In example 1, as the second circuit is to be cyclically operated, specify the cycle program by pressing the **Cycle** key.

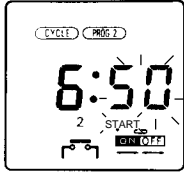

Set the start time (6:50) first. Set the hour to 6 and the minute to 50 by pressing the + or – key. Write each set value with the **Write** key.

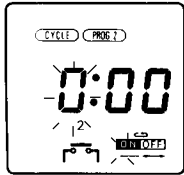

Then, set the ON time, which is 0:05 in this example.

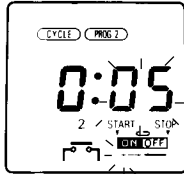

Write the hour of 0 by pressing the **Write** key.
Set the minute to 5 and store it in memory by using the **Write** key.

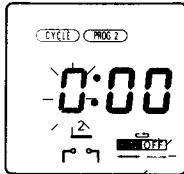

Next, set the OFF time.
The OFF time is to be 0:20.

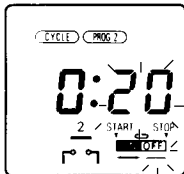

Finally, by pressing the Write key, set the hour to 0. In addition, set the minute to 20 by pressing the + or – key. Write it by pressing the **Write** key.

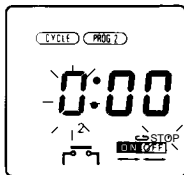

Next, set the time at which the cyclic circuit operation is to be stopped. The stop time is to be 20:30.

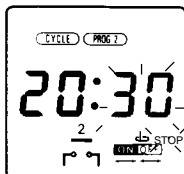

Set the hour to 20 by pressing the + or – key followed by the **Write** key. Set the minute to 30 by the + or – key followed by the **Write** key.

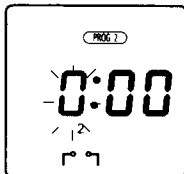

Now, the programming of the cyclic operation is completed.
The display is as shown on the left and waits for the next program to be input. Since the second circuit operation in example 1 has been completed, let's move to setting the day of the week.

Second Circuit Day-of-the-Week Setting

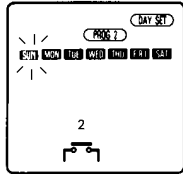

Press the **MODE** key to set the H5L in the DAY SET mode of the PROG 2 mode.

The display will be as shown on the left.

As the initial condition, the second circuit is to be operated on all the days of the week, which means all the indications by the day indicators are reverse video except that of the SUN indicator which blinks.

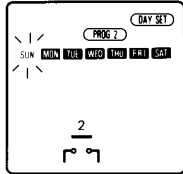

In example 1, the second circuit is not operated on Sunday but on all the other days; set Sunday to be stopped accordingly using the – key and the **Write** key.

Then, the MON indicator starts blinking. Since on Monday through Saturday the operation is set to be activated as the initial condition, there is no more need to set the operation.

Running the Program

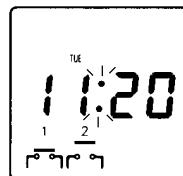

Now all the parameters have been programmed as in example 1. Press the **MODE**

key to set the H5L in the RUN mode.

The display will be as shown on the left.

The output status indicators show the current status of both outputs.

PROGRAMMING ERRORS

1. When the OFF time is set at the same hour and minute as the ON time, "hour" indicator blinks twice the normal rate for showing a program error. In this case, set the OFF (or ON) time again.
2. When the ON/OFF program is superimposed on the cyclic period (from cycle start to cycle stop), the program error is indicated as shown below. Set the "hour" and "minute" outside the cyclic period.
3. When a cycle program is superimposed on the existing program (ON time, OFF time, or cycle program), the program error is indicated as shown below. Change the start time or stop time of the cycle program not to overlap the other existing program.

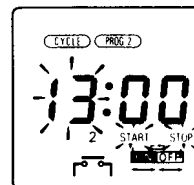
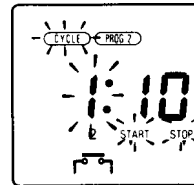

Mounting

The H5L timer comes with mounting brackets for panel and surface mounting. A slot on the back of the case allows H5L to be track mounted.

■ PANEL MOUNTING

Use the U-shaped mounting bracket supplied.

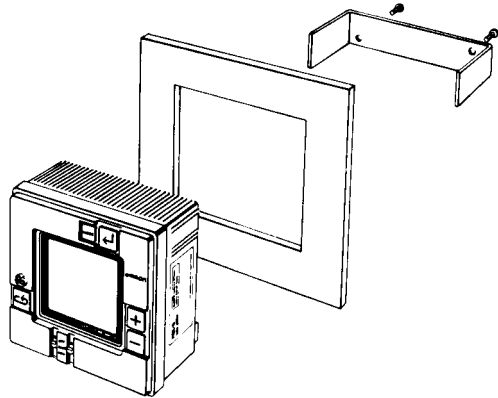

Dimensions

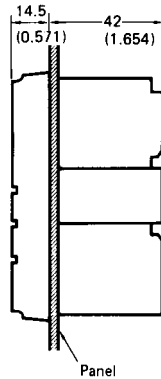

Panel cutout

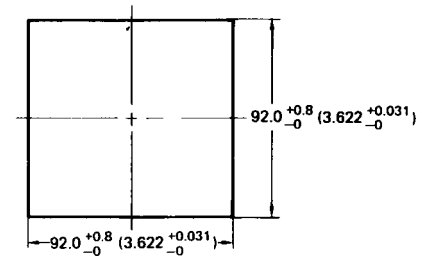

■ SURFACE MOUNTING

Use the straight mounting bracket supplied.

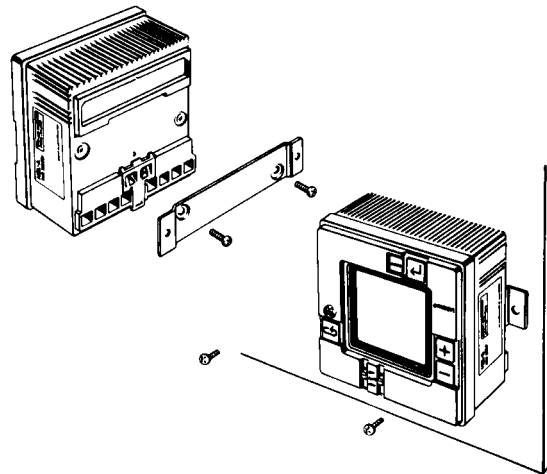

Mounting holes

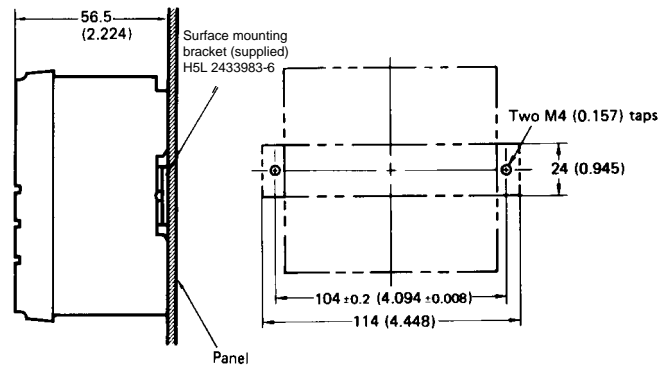

■ TRACK MOUNTING

Hook the upper part on the rear surface to the upper edge of the mounting track and press the unit down.

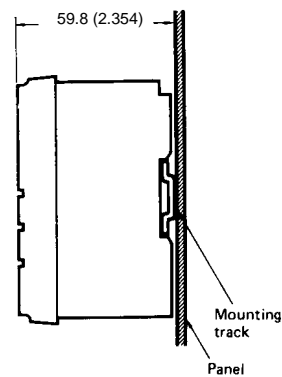
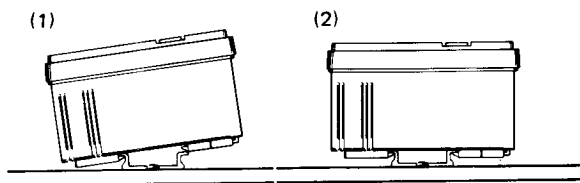

NOTE: ALL DIMENSIONS ARE IN MILLIMETERS. To convert millimeters into inches divide by 25.4.

OMRON

OMRON ELECTRONICS, INC.

One East Commerce Drive
Schaumburg, IL 60173

1-800-55-OMRON

OMRON CANADA, INC.

885 Milner Avenue
Scarborough, Ontario M1B 5V8

416-286-6465

X-ON Electronics

Largest Supplier of Electrical and Electronic Components

Click to view similar products for [Timers](#) category:

Click to view products by [Omron](#) manufacturer:

Other Similar products are found below :

[79237785](#) [H5AN-4DM DC12-24](#) [H5CN-YAN AC100-240](#) [H5CX-L8S-N AC100-240](#) [H5AN-4D DC12-24](#) [THR2U-110A](#) [81506944](#)
[88225029](#) [H5S-YB4-X](#) [H7AN-2D DC12-24](#) [H5CN-XANS DC12-48](#) [H7AN-W4DM DC12-24](#) [H7AN-4DM DC12-24](#) [H7AN-4D DC12-24](#)
[H7AN-RT6M AC100-240](#) [600DT-CU](#) [7PV1513-1AP30](#) [7PV1538-1AW30](#) [1SVR508100R0000](#) [1SVR550127R4100](#) [1SVR550212R4100](#)
[1SVR730010R3200](#) [1SVR730020R3300](#) [1SVR730120R3100](#) [1SVR730180R3100](#) [1SVR730211R2300](#) [PCU-511UNI](#) [H3C-R](#) [H3CR-A8-301](#)
[24-48AC/12-48DC](#) [H3CR-A8E 24-48AC/DC](#) [H3CR-F8 100-240AC/100-125DC](#) [H3CR-FN 100-240AC/100-125DC](#) [H3DK-G 24-230AC/DC](#)
[H3DK-HBL AC/DC24-48](#) [H3DK-M1A DC12](#) [LT4H-AC24V](#) [LT4HW8-AC240V](#) [LT4HW-AC240V](#) [LT4HW-AC24VS](#) [31L48AP](#)
[31L48TPM240](#) [RC302](#) [RC312](#) [REV-201M](#) [RG](#) [AT78041](#) [AT78051](#) [ATC180041](#) [TMM1](#) [TMP](#)