

Motor Condition Monitoring Device

K6CM

Quantifying the status of a three-phase induction motor and pump.

The alarm output threshold default is set. You can customize the value according to the site.

As for comprehensive current diagnosis, the degradation can be detected comprehensively by combining each motor part and the load side.

The insulation resistance of the three-phase induction motor and pump can be measured with current flowing (the secondary side leakage current of the inverter can also be detected).



* ZCT (IRT) is compatible with UL Recognition



For the most recent information on models that have been certified for safety standards, refer to your OMRON website.

Features

- Since the condition of the motor can be displayed in numeric values on the LCD, the motor condition can be checked without a dedicated tool.
- The alarm output settings can be made according to the device, with reference to the threshold value that has already been set by default.
- Depending on the threshold value setting for alarm output, the condition of the motor can be displayed on an alarm bar in three colors; Green (normal), Yellow (warning), and Red (critical).
- Equipped with a transistor output that externally outputs the status of the motor and error states of the K6CM main unit.
- Monitoring can be performed easily on the PC by EtherNet/IP communication and a dedicated tool.
- The numeric values of vibrations, temperature, insulation resistance, and current can be monitored by the same dedicated tool.
- The trend of the motor condition can be monitored by a dedicated tool, and thus indications of a degradation can be monitored.
- Clamp-type CT/ZCT that supports easy post installation. With a clamp-type CT/ZCT, the device can be installed without changing or removing the existing wiring, which makes post-installation easy.
- Comes with the self-diagnosis function of the main unit internal circuit and analog sensing circuit.
- Push-in Plus Terminal Technology reduces wiring work (double-insertion holes for crossover wiring).
- UL listed for easy shipping to North America (ZCT (IRT) is UL recognized).

Windows is a registered trademark of Microsoft Corporation in the United States and or other countries.

EtherNet/IP™ is the trademarks of ODVA.

Other company names and product names in this document are the trademarks or registered trademarks of their respective companies.

K6CM

System Configuration

Basic Configuration

Vibration & temperature type (K6CM-VB)

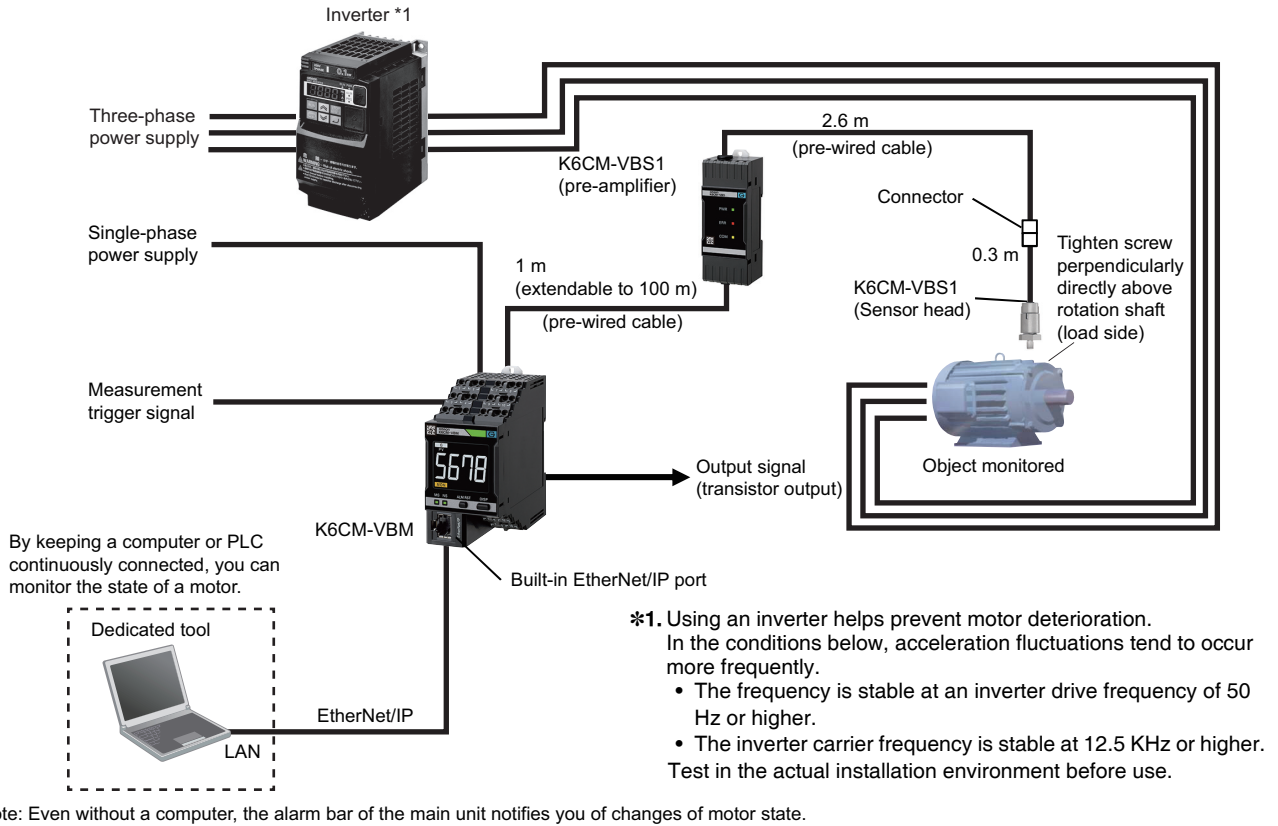

Insulation resistance type (K6CM-IS) Three-phase, three-conductor, S-phase ground

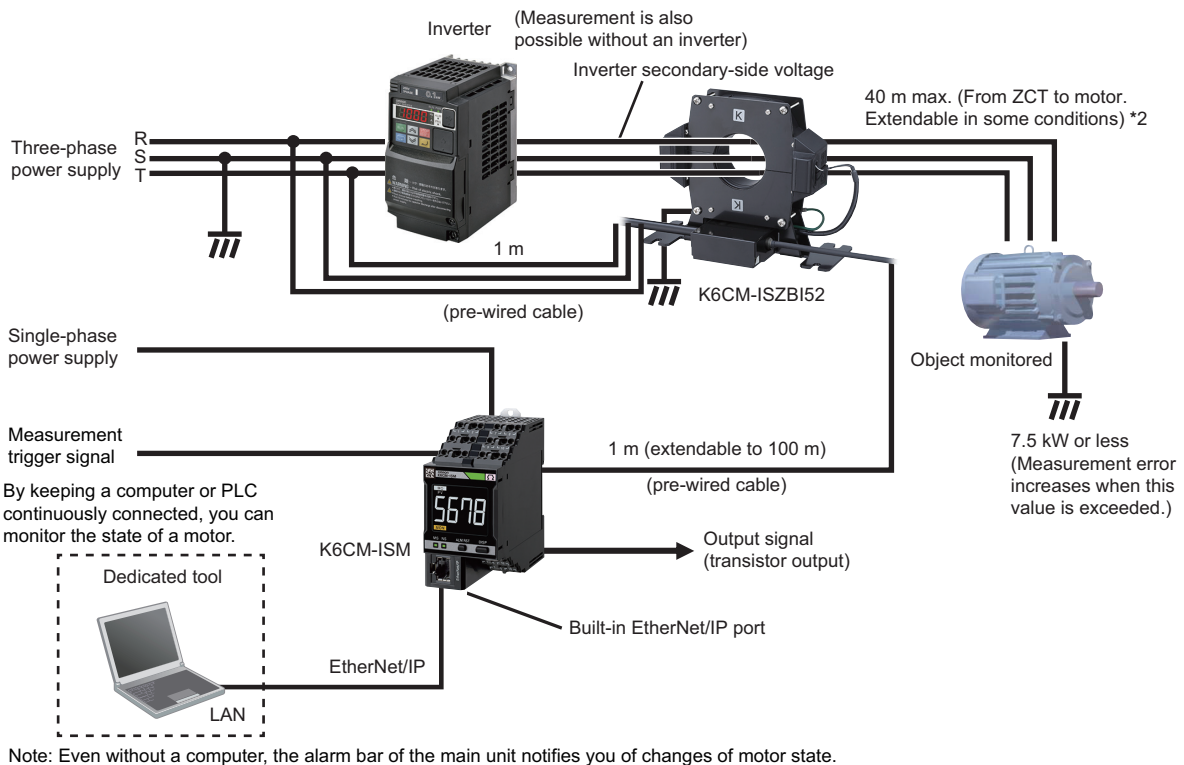

*2. For details, refer to the technical data on page 16.

Three-phase, four-conductor, N-phase ground

Note: When an inverter is used with three-phase, four-conductor, N-phase ground, correct measurement is not possible

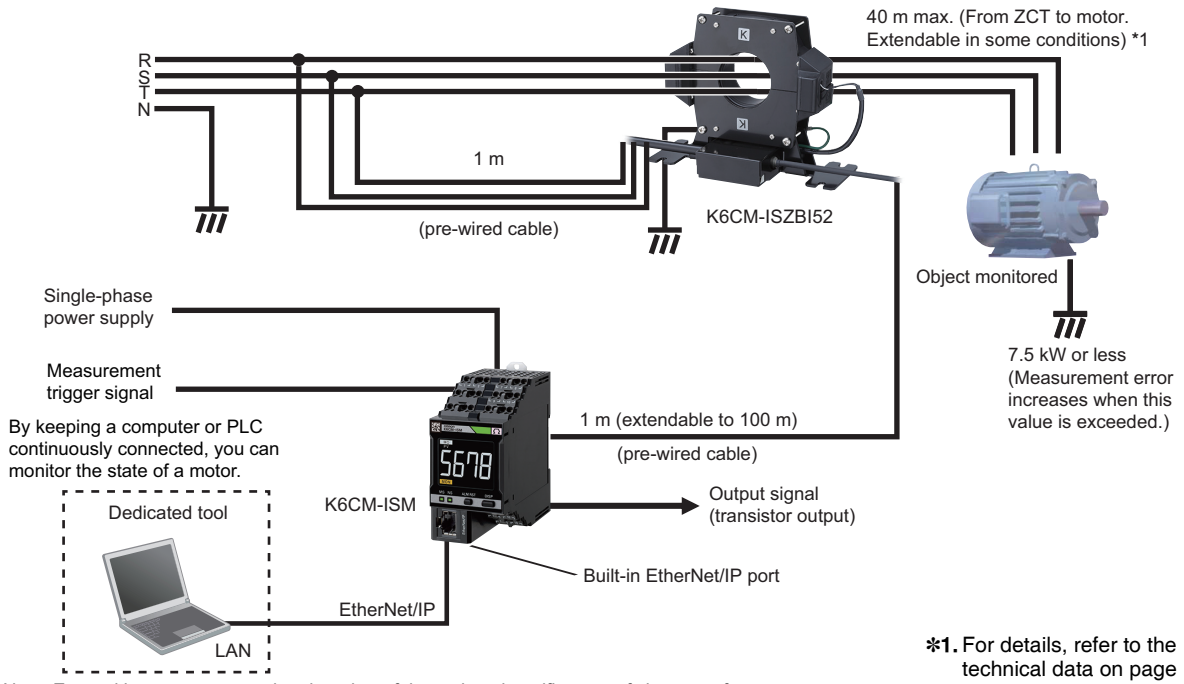

Comprehensive current diagnosis type (K6CM-CI)

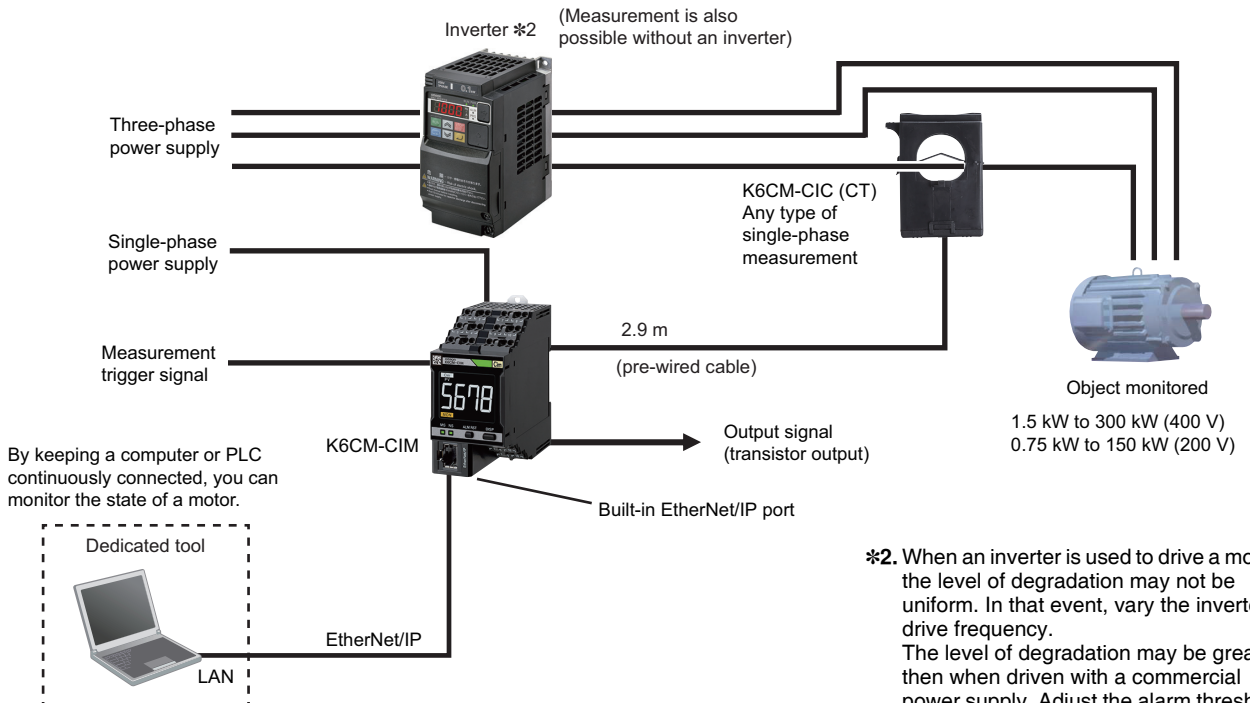

Note : 1. Even without a computer, the alarm bar of the main unit notifies you of changes of motor state.
2. The degradation level may appear differently depending on the failure condition of the motor or load, or depending on the installation condition.

*2. When an inverter is used to drive a motor, the level of degradation may not be uniform. In that event, vary the inverter drive frequency. The level of degradation may be greater then when driven with a commercial power supply. Adjust the alarm threshold appropriately for the motor drive method. Always measure and monitor the level of degradation using the same inverter drive frequency.

K6CM



Ordering Information

List of Models

Monitoring type	Power supply voltage	Model
Vibration & temperature type	100 to 240 VAC	K6CM-VBMA-EIP
	24 VAC/VDC	K6CM-VBMD-EIP
Insulation resistance type	100 to 240 VAC	K6CM-ISMA-EIP
	24 VAC/VDC	K6CM-ISMD-EIP
Comprehensive current diagnosis type	100 to 240 VAC	K6CM-CIMA-EIP
	24 VAC/VDC	K6CM-CIMD-EIP

Input part

Vibration & temperature sensor (Order separately)

Appearance (pre-amplifier)	Appearance (sensor head)	Attachment part	Applicable Relay	Model
		M6 screw	K6CM-VBM	K6CM-VBS1

Note: The vibration and temperature sensor consists of a sensor head and a pre-amplifier.
A magnet is provided for the easy attachment of the vibration and temperature sensor.

ZCT (IRT) (Order separately)

Rated voltage	Through hole dia. (mm)	Applicable Relay	Model
200 to 480 VAC	52 dia.	K6CM-ISM	K6CM-ISZBI52

Note: ZCT (IRT) is the abbreviation for Zero Current Transfer (Insulation Resistance Transfer).
A cable for connection is provided with the ZCT (IRT).

CT (Order separately)



Rated primary-side current	Applicable Relay	Model
5 A	K6CM-CIM	K6CM-CICB005
25 A		K6CM-CICB025
100 A		K6CM-CICB100
200 A		K6CM-CICB200
400 A		K6CM-CICB400
600 A		K6CM-CICB600

Note: A cable for connection is provided with the CT. Select a CT that sets the current of the applicable motor within the measurement range.
To calculate the current, refer to *Comprehensive Current Diagnosis Type Technical Data (Reference)* on page 17.

EtherNet/IP communication cable recommended parts

Use a Category 5 or higher STP cable (shielded twisted pair cable).

Cable with Connectors

Item		Recommended manufacturer	Cable length (m)	Model
Wire Gauge and Number of Pairs: AWG26, 4-pair Cable Cable Sheath material: LSZH *2	Cable with Connectors on Both Ends (RJ45/RJ45) Standard RJ45 plug type *1 Cable color: Yellow *3 	OMRON	0.3	XS6W-6LSZH8SS30CM-Y
			0.5	XS6W-6LSZH8SS50CM-Y
			1	XS6W-6LSZH8SS100CM-Y
			2	XS6W-6LSZH8SS200CM-Y
			3	XS6W-6LSZH8SS300CM-Y
			5	XS6W-6LSZH8SS500CM-Y
Wire Gauge and Number of Pairs: AWG22, 2-pair Cable	Cable with Connectors on Both Ends (RJ45/RJ45) Rugged RJ45 plug type *1 Cable color: Light blue 	OMRON	0.3	XS5W-T421-AMD-K
			0.5	XS5W-T421-BMD-K
			1	XS5W-T421-CMD-K
			2	XS5W-T421-DMD-K
			5	XS5W-T421-GMD-K
			10	XS5W-T421-JMD-K

*1. Cables with standard RJ45 plugs are available in the following lengths: 0.2 m, 0.3 m, 0.5 m, 1 m, 1.5 m, 2 m, 3 m, 5 m, 7.5 m, 10 m, 15 m, 20 m.
Cables with rugged RJ45 plugs are available in the following lengths: 0.3 m, 0.5 m, 1 m, 2 m, 3 m, 5 m, 10 m, 15 m.

For details, refer to the *Industrial Ethernet Connectors Catalog* (Cat. No. G019).

*2. The lineup features Low Smoke Zero Halogen cables for in-cabinet use and PUR cables for out-of-cabinet use.



*3. Cable colors are available in yellow, green, and blue. The last character of the model changes to "-G" or "-B".

Cable/Connector

Part name	Manufacturer	Model
Cable	Hitachi Metals, Ltd.	NETSTAR-C5E SA 0.5 × 4P *
RJ45 connector	Panduit Corporation	MPS588-C *

* It is recommended to use the cable and connector in combination described above.

Industrial switching hub (recommended parts)

Product name	Appearance	Specifications			Model
		Function	No. of ports	Failure detection function	
Industrial switching hub		Priority control (QoS): EtherNet/IP control data priority Failure detection: Broadcast storm / LSI failure detection 10/100BASE-TX, Auto-Negotiation	3	×	W4S1-03B
			5	×	W4S1-05B
			5	○	W4S1-05C

List of Combinations

As for the K6CM, it is necessary to provide a combination of a vibration and temperature sensor, ZCT (IRT), and CT for the main unit and each model.

One sensor must be provided for one main unit.

○: Can be combined, ---: Cannot be combined

		State monitoring components		
		K6CM-VBMA-EIP/ K6CM-VBMD-EIP	K6CM-ISMA-EIP/ K6CM-ISMD-EIP	K6CM-CIMA-EIP/ K6CM-CIMD-EIP
Vibration & temperature sensor	K6CM-VBS1	○	---	---
ZCT (IRT)	K6CM-ISZBI52	---	○	---
CT	K6CM-CICB005	---	---	○
	K6CM-CICB025	---	---	○
	K6CM-CICB100	---	---	○
	K6CM-CICB200	---	---	○
	K6CM-CICB400	---	---	○
	K6CM-CICB600	---	---	○

K6CM

Ratings and Specifications

List of Models

Ratings

Power Supply	Power supply voltage		K6CM-□□MA: 100 to 240 VAC, 50/60 Hz K6CM-□□MD: 24 VAC, 50/60 Hz, 24 VDC
	Allowable operating voltage range		85% to 110% of power supply voltage
	Power supply frequency range		45 to 65 Hz
	Power consumption		K6CM-VBM□ 24 VAC/24 VDC: 3.8 VA/2.1 W max. 100 to 240 VAC: 7.1 VA max. K6CM-ISM□ 24 VAC/24 VDC: 3.7 VA/2.0 W max. 100 to 240 VAC: 6.2 VA max. K6CM-CIM□ 24 VAC/24 VDC: 3.1 VA/1.6 W max. 100 to 240 VAC: 6.0 VA max.
Input	Vibrations (vibration sensor)	Detection frequency	10 Hz to 10 kHz
		Max. operating acceleration	10 G
	Insulation resistance (ZCT (IRT))	Rated input voltage	(Line voltage) 200 to 480 VAC, 50 Hz/60 Hz
		Rated path current	300 AAC
Current, comprehensive current diagnosis (CT)	Rated input current	5 A, 25 A, 100 A, 200 A, 400 A, 600 A	
Applicable motor type			Three-phase induction motor (Rated voltage 480 V or less)
Outputs	Output form		Transistor output
	Output capacity		3-point
	Output rating		Rated voltage: 24 VDC Max. current: 50 mA, DC
Ambient operating temperature			-10 to +55°C (with no condensation or icing)
Storage temperature			-20 to +65°C (with no condensation or icing)
Ambient operating humidity			25% to 85% RH (with no condensation)
Storage humidity			25% to 85% RH (with no condensation)
Case color			Black
Case material			Polycarbonate UL94-V0
Altitude			2,000 m max.
Applicable wires			Stranded wires, solid wires, or ferrules
Applicable wire size			0.25 to 1.5 mm ² (AWG24 to 16)
Wire insertion force			8 N max. (AWG20)
Screwdriver insertion force			15 N max.
Wire stripping length			8 mm
Recommended flat-blade screwdriver			XW4Z-00B (Omron)
Current capacity			10 A (per pole)
Number of insertions			50 times
Weight			Approx. 200 g
Mounting			Mounts to DIN Track screw mounting
Dimensions			45 (W) × 90 (H) × 90 (D) mm
Setting method			Communication settings from a dedicated tool via EtherNet/IP
Other functions			Display value selection, self-diagnosis error output, setting value initialization, operation integration
Accessories			Operation manual, CD-ROM (Motor condition monitoring Tool)

Characteristics

Measurement range	K6CM-VB	Acceleration: 0.05 to 9.99 G, Velocity: 0.90 to 45.00 mm/s, Motor temperature: 0 to 80°C, Differential temperature: 0 to 80°C		
	K6CM-IS	Insulation resistance: 0.000 M to 1.000 MΩ, Leakage current: 0.0 mA to 200.0 mA		
	K6CM-CI	Current Rating 5 A: 1.00 to 5.00 A Rating 25 A: 5.0 to 25.0 A Rating 100 A: 20.0 to 100.0 A Rating 200 A: 40.0 to 200.0 A Rating 400 A: 80.0 to 400.0 A Rating 600 A: 120.0 to 600.0 A Rated frequency: 20 to 80 Hz Degradation level: 0 to 999 Recommended frequency: 20 to 80 Hz *1		
Measurement absolute accuracy	K6CM-VB	Acceleration	±3 dB±2 digit (at 25°C)	
		Temperature	Motor temperature: ±3°C±2 digit (±6°F±2 digit) Temperature Gap: ±6°C±2 digit (±12°F±2 digit)	
	K6CM-IS	Insulation resistance	±35% rdg±2 digit (when the insulation resistance is 0.2 MΩ max.), when a 200-V/7.5-kW max. motor is used *2 ±35% rdg±2 digit (when the insulation resistance is 0.4 MΩ max.), when a 400-V/7.5-kW max. motor is used *2	
	K6CM-CI	Current	±1.0% FS±1 digit (at 10 to 30°C, CT variation is not included) *3	
Sampling cycle	K6CM-VB	Acceleration: 50 ms, Velocity: 0.5 s, Temperature: 0.5 s		
	K6CM-IS	Normal mode: 10 s, Inverter special measurement mode: 60 s		
	K6CM-CI	Comprehensive current diagnosis: 5 s, Current: 5 s		
Moving average frequency				
1, 2, 4, 8, 16, 32 times				
External trigger *4	External contact input specification		Short-circuit: Residual voltage 1.5 V max. Open: Leakage current 0.1 mA max.	
	Current during short-circuiting		Approx. 7 mA	
Transistor output				
Contact configuration: NPN open collector Rated voltage: 24 VDC (maximum voltage: 26.4 VDC) Max. current: 50 mA, DC				
Alarm	Parameters that can be output		K6CM-VB: Acceleration, Velocity, motor temperature, Temperature Gap K6CM-IS: Insulation resistance K6CM-CI: Degradation level, current	
	Expression method			Transistor output, alarm bar
	Setting value	K6CM-VB	Acceleration: 0.00 to 99.99 G, Velocity: 0.00 to 99.99 mm/s, Motor temperature: 0 to 9999 deg., Differential temperature: 0 to 9999 deg.	
		K6CM-IS	Insulation resistance: 0.000 M to 9.999 MΩ	
		K6CM-CI	Current Rating 5 A: 00.00 to 99.99 A Rating 25 A/100 A/ 200 A/400 A/600 A: 0.0 to 999.9 A Degradation level: 0 to 999	
	Hysteresis		10% width of setting value	
Reset method		Manual reset/automatic reset (switchable) * Manual return method: Press the ALMRST button		
LCD display				
7-Segment digital display and single-shot display Font height 14 mm				
Applicable standards	Conforming standards			
	EN61010-2-030 Installation environment: Pollution degree 2, overvoltage category II, measurement category II			
	EMC			
EN61326-1(EMI: Class A EMS: Industrial Location) Acceleration ± 0.1G, Velocity ±2.25mm/s, Temperature ± 6°C, insulation resistance ± 35% rdg, current ± 10% F.S.				
Safety standards				
UL61010-2-030 (listing) Korean Radio Waves Act (Act 10564) RCM EAC				
Insulation resistance				
20 MΩ min. Between all external terminals and the case Between all power supply terminals and all other terminals Between all sensor connection terminals and trigger input terminal + output terminal + all EtherNet/IP ports				
Dielectric strength				
2,000 VAC for 1 minute Between all external terminals and the case Between all power supply terminals and all other terminals Between all sensor connection terminals and trigger input terminal + output terminal + all EtherNet/IP ports				
Vibration resistance				
Vibration frequency 10 to 55 Hz, slice amplitude 0.35 mm in each of X, Y, Z directions 5 minute × 10				
Shock resistance				
100 m/s ² , 3 times each in 6 directions along 3 axes				
Degree of protection				
IP20				
LED display	Alarm bar		Red/Yellow/Green	
	MS, NS *5		Red/Green	
Ethernet communication	Number of ports		1	
	Physical layer		Ethernet: Connector RJ45	
	Type		100BASE-TX	
	Transmission distance (Maximum cable length)		100 m (Between hub and node)	
	Topology		Star type	

*1. When used at a frequency higher than 80 Hz, the tendency toward motor degradation is less noticeable.

*2. For details, refer to the technical data on page 16.

*3. For the frequency characteristics of the CT, refer to the technical data on page 18.

*4. The external trigger function can be used only when the insulation resistance type is EIP CPU version 1.1 or higher.

*5. MS: Product status display, NS: Network status display.

Input part Vibration & temperature sensor Ratings

Item	Model	K6CM-VBS1
Power supply voltage		Supplied from K6CM-VBM
Sensor head	Max. acceleration	10 G
Ambient operating temperature		Pre-amplifier: -10 to +55°C (with no condensation or icing) Sensor head: -10 to +80°C (with no condensation or icing)
Storage temperature		Pre-amplifier: -20 to +65°C (with no condensation or icing) Sensor head: -20 to +90°C (with no condensation or icing)
Ambient operating humidity		25% to 85% RH (with no condensation)
Storage humidity		25% to 85% RH (with no condensation)
Altitude		2,000 m max.
Case color		Pre-amplifier: Black Sensor head: Silver
Case material		Pre-amplifier: Polycarbonate UL94-V0 Sensor head: Aluminum alloy (ADC12) / Zinc die casting (ZDC2) (the threaded part is Steel (S45C))
Weight		Pre-amplifier: Approx. 210 g (including cables) Sensor head: Approx. 40 g (including cables)
Mounting		Pre-amplifier: DIN rail mounting, screw mounting Sensor head: Screw mounting Between pre-amplifier and sensor head: Connector connection (smart click connector)
Wire length		Between pre-amplifier and sensor head: 2.6 m+0.3 m (cannot be extended) Between pre-amplifier and main unit: 1 m Can be extended up to a maximum length of 100 m

Characteristics

Item	Model	K6CM-VBS1
Measurement range		Specified in main unit "Characteristics"
Applicable standards	Conforming standards	EN 61010-2-030 Installation environment: Pollution degree 2, overvoltage category II, measurement category II
	EMC	EN 61326-1 (EMI: Class A EMS: Industrial Location)
	Safety standards	UL 61010-2-030 (listing) RCM EAC
Insulation resistance		20 MΩ min.
Dielectric strength		500 VAC for one minute
Vibration resistance	Pre-amplifier	Vibration frequency 10 to 55 Hz, slice amplitude 0.35 mm in each of X, Y, Z directions 5 minute × 10
	Sensor head	Vibration frequency 10 to 55 Hz, slice amplitude 0.35 mm in each of X, Y, Z directions 5 minute × 10
Shock resistance	Pre-amplifier	100 m/s ² , 3 times each in 6 directions along 3 axes
	Sensor head	100 m/s ² , 3 times each in 6 directions along 3 axes
Degree of protection	Pre-amplifier	IP20 (excluding the sensor-side cable)
	Sensor head	Conforming to IP67G (JIS C 0920 : 2003, Appendix 1)
LED display		Pre-amplifier PWR: Green, ERR: Red, COM: Orange

ZCT (IRT) Ratings and Specifications

Item	Model	K6CM-ISZBI52
Construction		Indoor split type
Rated path current		300 A
Through hole dia.		52 mm dia.
Rated voltage		200 to 480 VAC, 50 Hz/60 Hz three phase
Measurement range		Specified in main unit "Characteristics"
Measurement accuracy		Specified in main unit "Characteristics"
Voltage input terminal		3-terminal lead wire, Length: 1m (pre-wired cable)
Output terminal		4-terminal lead wire, Length: 1m (pre-wired cable) Available wire length 100 m max.
Applicable standards	Conforming standards	EN 61010-2-030 Installation environment: Pollution degree 2, overvoltage category II, measurement category II
	EMC	EN 61326-1 (EMI: Class A EMS: Industrial Location)
	Safety standards	UL 61010-2-030 (Recognition) + CSA C22.2 No. 61010-2-030 RCM EAC
Insulation resistance		Between Mounting bracket - Secondary winding: 100 MΩ min.
Dielectric strength		Between Mounting bracket - Secondary winding: 2000 VAC, 1 minute
Ambient operating temperature		-10 to +55°C (with no condensation or icing)
Ambient operating humidity		25 to 85% (with no condensation)
Weight		Approx. 2.3 kg (including cables)
Degree of protection		IP20

CT Ratings and Specifications

Item	Model	K6CM-CICB005	K6CM-CICB025	K6CM-CICB100	K6CM-CICB200	K6CM-CICB400	K6CM-CICB600
Construction		Indoor split type					
Primary-side rated current		5 A	25 A	100 A	200 A	400 A	600 A
Measurement range *1		1 to 5 A	5 to 25 A	20 to 100 A	40 to 200 A	80 to 400 A	120 to 600 A
Secondary-side rated current		Dedicated current					
Secondary winding		3000 turns			6000 turns	9000 turns	
Insulation resistance		Between output terminal and case: 50 MΩ min.					
Dielectric strength		Between output terminal and case: 2,000 VAC, 1 minute					
Protective element		7.5 V clamp element					
Permissible attachment/removal frequency		100 times					
Attachable wire diameter *2		7.9 mm dia. max.	9.5 mm dia. max.	14.5 mm dia. max.	24.0 mm dia. max.	35.5 mm dia. max.	
Operating temperature / humidity range		-20 to +60°C, 25 to 85% (with no condensation or icing)					
Storage temperature / humidity range		-30 to +65°C, 25 to 85% (with no condensation or icing)					
Supplied cable length		2.9 m (pre-wired cable)					
Supplied cable terminal	Main unit side	Ferrule terminal					
	CT side	Round terminal					
Degree of protection		IP20					

*1. Select a CT that brings the current of the applicable motor into the measurement range.

To calculate the current, refer to the technical data on page 18.

*2. When using a flat wire, be sure to refer to the external dimensions drawing of the CT before selection on page 15.

Motor condition monitoring Tool (Software included with main unit) Operating Environment

Element	Specification
Supported OS	Windows 7, Windows 8.1, Windows 10 (32 bit/64 bit) (Japanese/English)
.NET	.NET Framework 4 and .NET Framework 3.5
CPU	1 GHz or more, 32 bit or 64 bit processor
Memory	1 GB or more, or 2 GB or more (for 64 bit)
HDD	Available space of 16 GB or more, or 20 GB or more (for 64 bit)
Others	Since this software is provided on a CD-ROM, a CD-ROM reading device must be available. If data is to be collected, a LAN I/F must be available.

Functions/Specifications (For more details, refer to the catalog of each product.)

Item		Specification
Project	Number of files that can be created	No limit
Log file		CSV data format
Monitoring cycle		5 second to 99999 second (one-second step)
Number that can be registered in one project	Number of motors (device groups)	10
	Number of devices per motor (device group)	3 *
Graphic display	Type of graph	Line graph
	Display period	1 hour, 1 day, 1 month, 3 months, 6 months, 1 year, 2 years, 5 years, 10 years, 20 years

* One vibration and temperature type, one insulation resistance type, and one current comprehensive diagnosis type can be set for one motor.

Connection Diagram

Terminal Diagram (Main Unit)

K6CM- VB M A -EIP
 (1) (2)

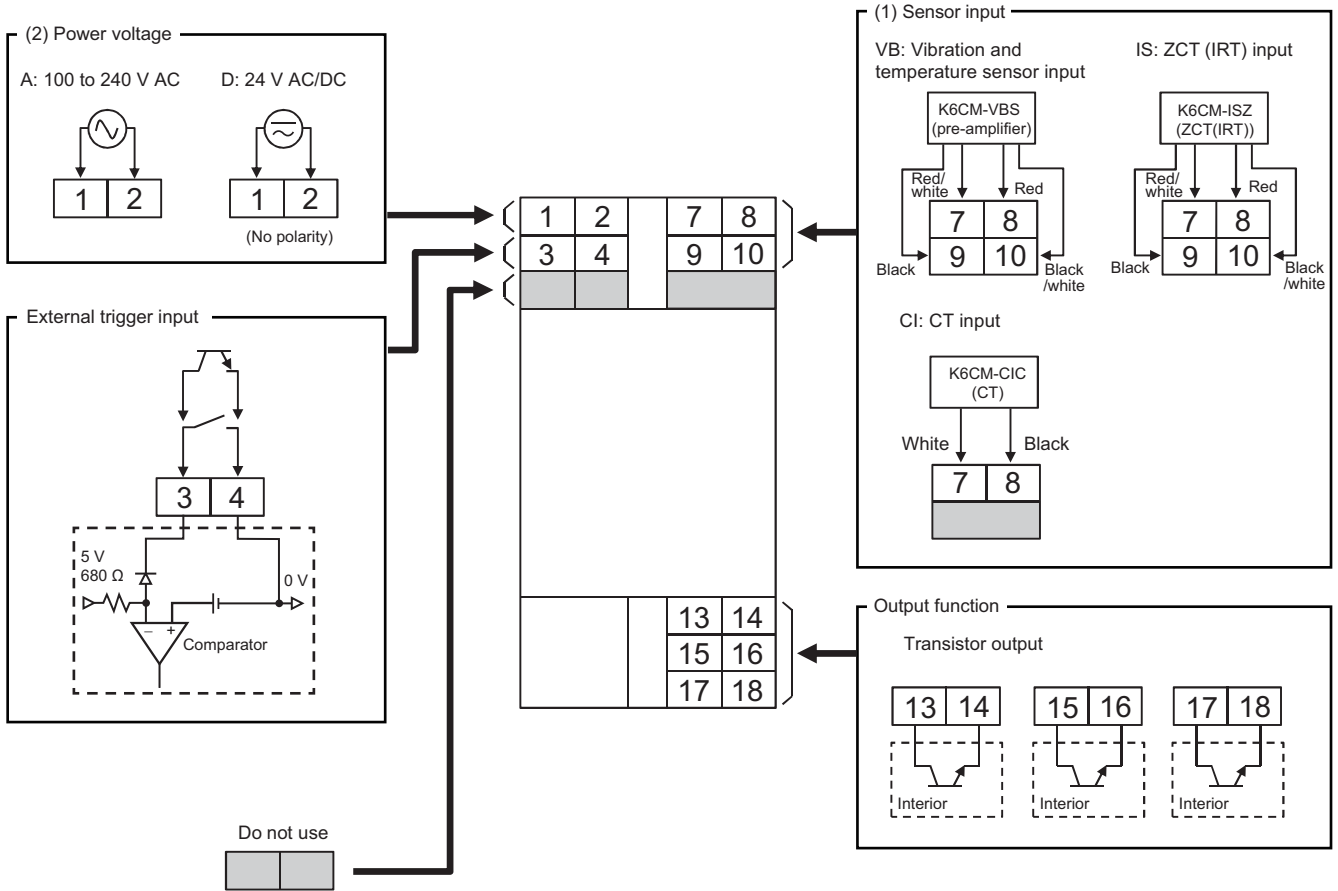

Nomenclature

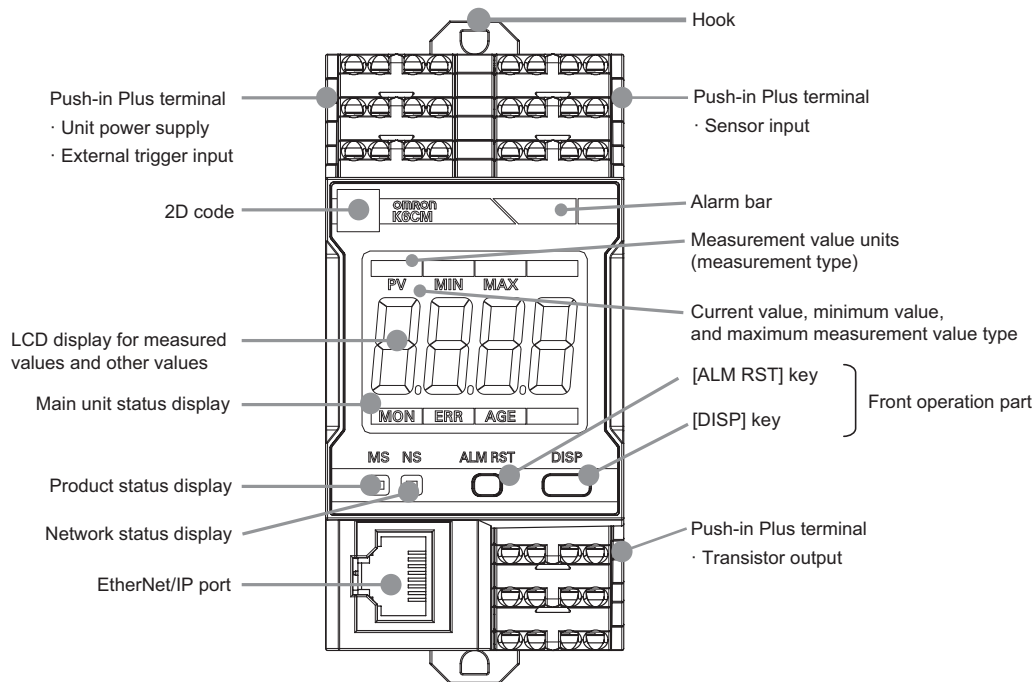

Name		Meaning	
Alarm bar		A bar on which the color of the emitted light changes according to the alarm status.	It is indicated in the following colors during measurement/monitoring. Green: Alarm status (normal) Yellow: Alarm status (Warning) Red: Alarm status (Critical) The alarm bar is lit out in each of the following states: When the power is OFF, when measurement is not being performed, and when a self-diagnosis error has occurred, etc.
Measurement type		Indicates the type of the measured value being displayed. The type can be switched each time the [DISP] key is pressed on the front operation part.	K6CM-VB "G": Acceleration, "mm/s": Velocity, "T": Motor temperature, "ΔT": Temperature Gap (difference between motor temperature and room temperature) K6CM-IS "MΩ": Insulation resistance, "mA": Leakage current K6CM-CI "Cim": Degradation level, "A": Current
Front operation part	[ALM RST] key	Releases the latched alarm state.	The main use of this key is to release the latched and fixed alarm state after returning from the fault state to the normal state.
	[DISP] key	Switches the type of the measured value being displayed.	
	Others	If two keys are simultaneously pressed and held for 5 seconds or longer, all settings of the main unit are reset to factory defaults.	
Main unit status display		The status of the main unit is indicated by lighting of the LCD characters.	"MON": Measurement / monitoring is being performed "ERR": A self-diagnosis error has occurred "AGE": Running Time notification (it is recommended to replace the product main unit)
Transistor output	13-14	Output of the alarm status (Warning). Can be set to Normally Closed or Normally Open.	When measurement/monitoring is in progress, and the output method is Normally Closed ON = Comprehensive alarm: Normal / OFF = Comprehensive alarm: Warning or Critical and the output method is Normally Open OFF = Comprehensive alarm: Normal / ON = Comprehensive alarm: Warning or Critical
	15-16	Output of the alarm status (Critical). Can be set to Normally Closed or Normally Open.	When measurement/monitoring is in progress, and the output method is Normally Closed ON = Comprehensive alarm: Warning or Normal / OFF = Comprehensive alarm: Critical and the output method is Normally Open OFF = Comprehensive alarm: Warning or Normal / ON = Comprehensive alarm: Critical
	17-18	Self-diagnosis error output.	OFF: A self-diagnosis error has occurred ON: Other than the above
External trigger input	3-4	Input of the external contact signal to control measurement timing.	You can use "Trigger Type" to specify whether measurement/monitoring continue for a set time after starting by the rise or fall of the external contact, or are executed while the external contact is ON. You can also specify settings to enable selection of a trigger mode other than external trigger. *

Note: Warning: Indicates that it is time for maintenance.
Critical: Indicates that it is time for replacement.

* Trigger modes other than external trigger

Always: Trigger is not used. Measurement/monitoring are performed continuously after the power of the K6CM unit is turned on.

Internal trigger: Measurement/monitoring starts based on the relation between the measured value and set value (trigger level).

You can use "Trigger Type" to specify whether measurement/monitoring start and continue for a set time when the measured value is over, or under, the set value (trigger level), or are executed while the measured value exceeds the set value (trigger level).

Also, the external trigger function can be used only when the insulation resistance type is EIP CPU version 1.1 or higher.

Dimensions

List of Models

K6CM-□□M

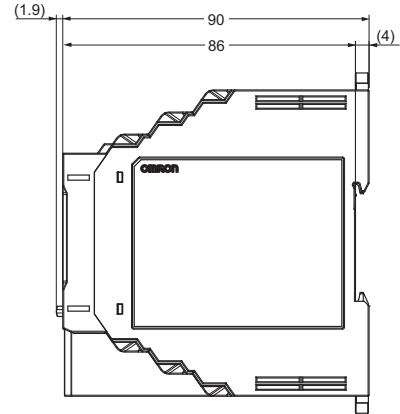
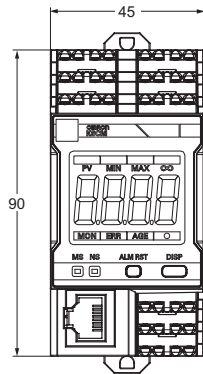

Vibration & temperature sensor

K6CM-VBS1

Pre-amplifier

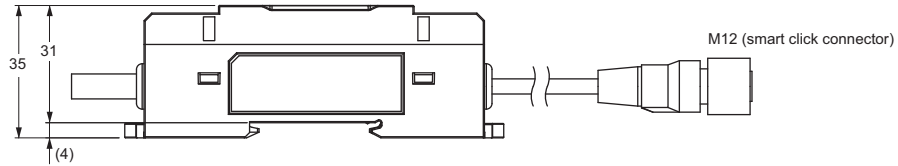
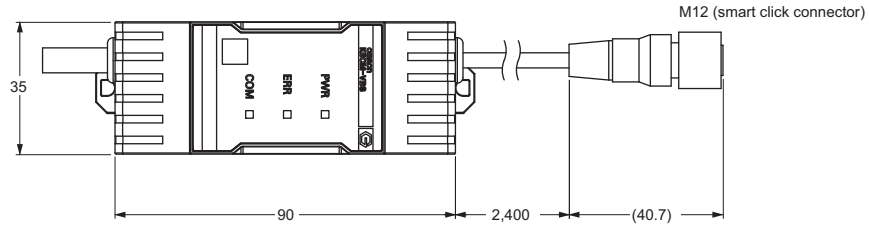

Sensor head

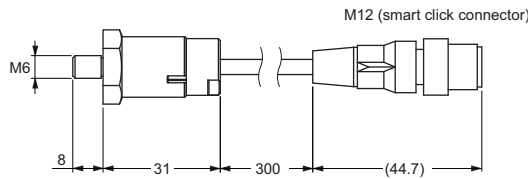
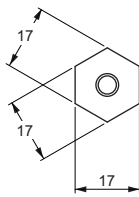

Mounting hole dimensions

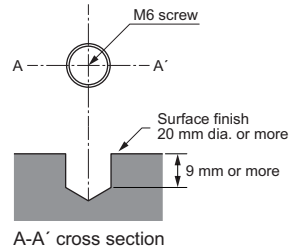

K6CM

ZCT (IRT)

Indoor split type
K6CM-ISZBI52

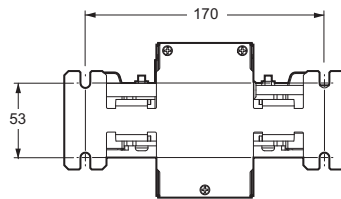
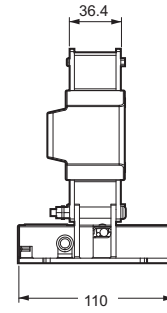
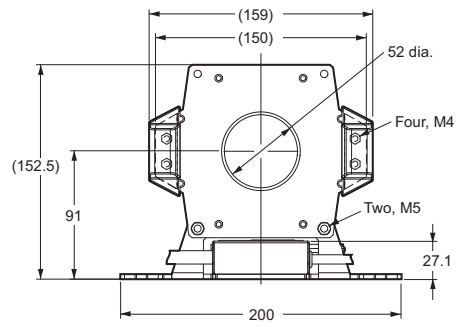
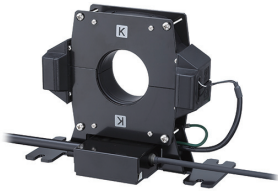

Mounting hole dimensions

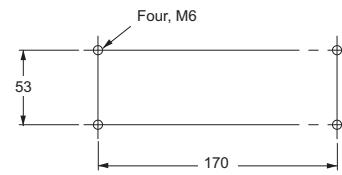

CT

K6CM-CICB005

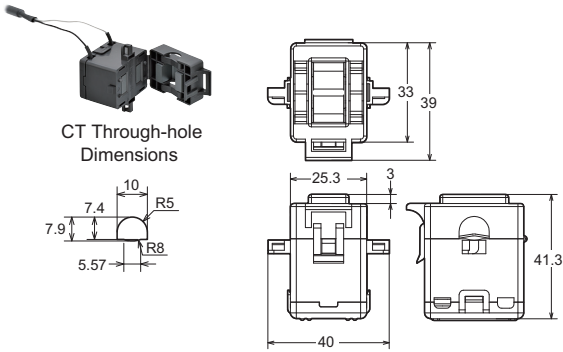

K6CM-CICB025

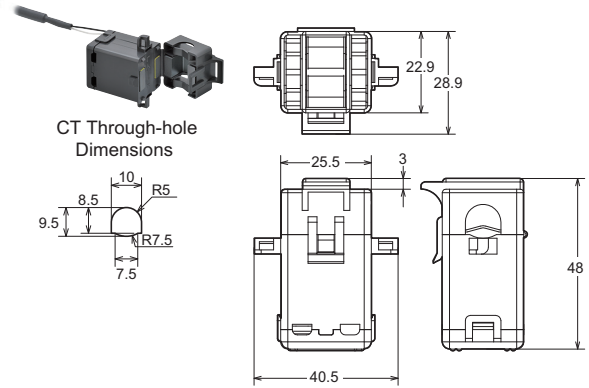

K6CM-CICB100

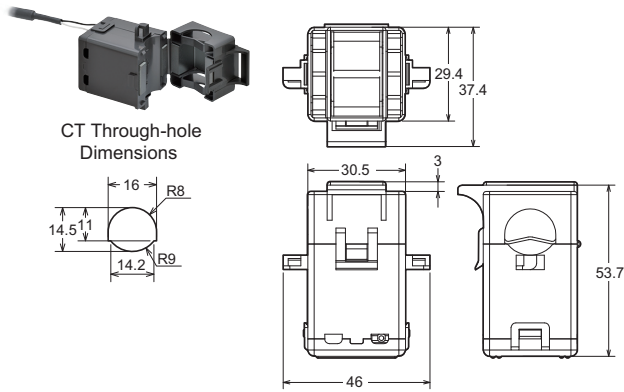

K6CM-CICB200

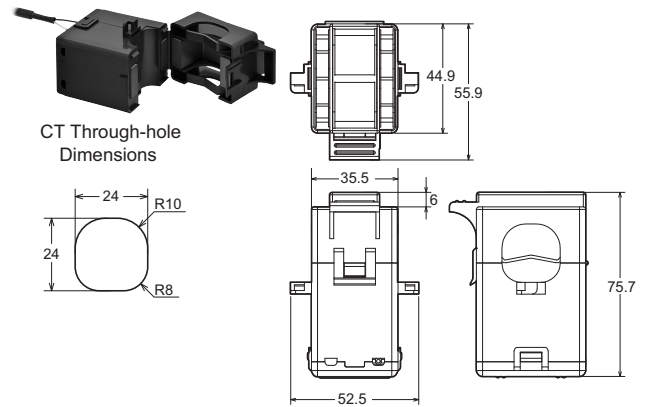

K6CM-CICB400
K6CM-CICB600

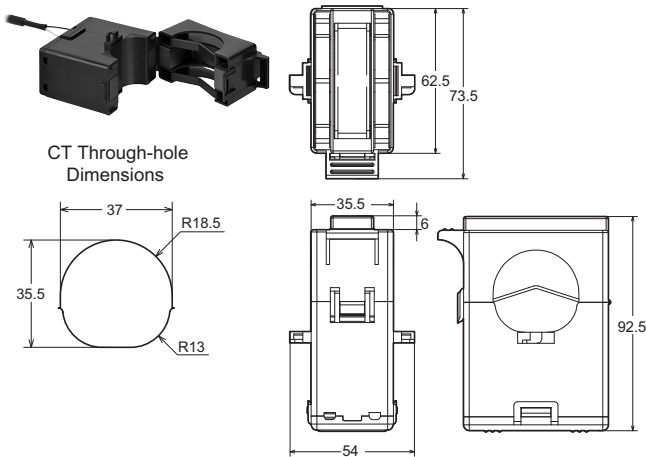

Cable supplied with CT

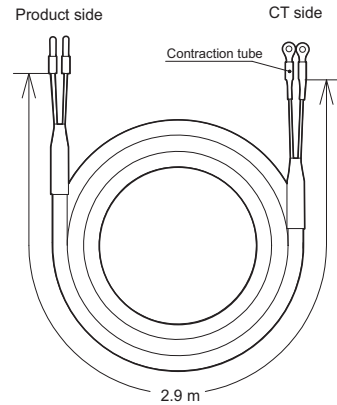

The cable supplied with the CT is shipped in the connected state.

Insulation Resistance Type Technical Data (Reference)

Method of measuring the value on the insulation resistance meter

Leakage current includes two types, namely capacitive leakage current (i_{oc}) that flows through the earth capacity, and resistive leakage current (i_{or}) that flows due to the degradation of wiring and devices, and is the cause of electric shock and fire. The leakage current is determined by detecting the value of the zero-phase current i_o , which is the combined component of i_{oc} and i_{or} . (See the figure below)

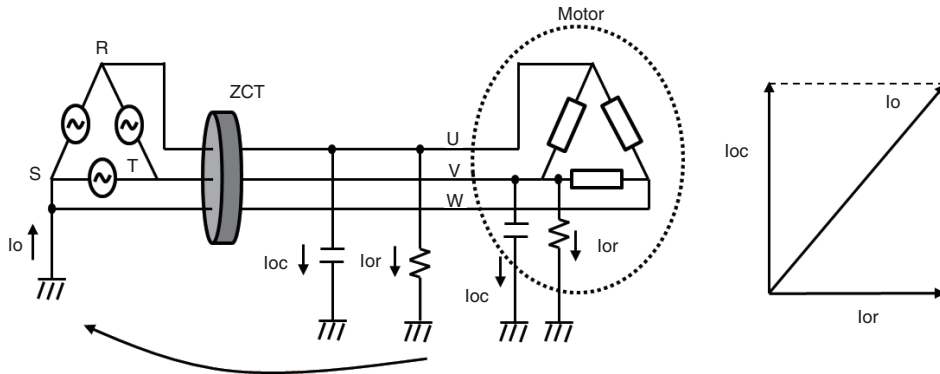

About changes in the measurement accuracy

If there is almost no insulation deterioration in the motor, almost the entire constituent of i_o becomes i_{oc} , and the measurement accuracy of i_{or} declines. Further, if the i_{oc} based on the motor-specific electrical capacitance is larger than i_{or} , then the measurement accuracy will similarly decline. Particularly, if the electrical capacitance increases in proportion to the capacitance of the motor, the measurement accuracy changes depending on the motor capacitance.

The following items are the possible parameters affecting the measurement accuracy.

- Increase in i_{oc} Type of motor (manufacturer, structure), capacitance, number of poles, and the length of wire between ZCT (IRT) and the motor
- Other noise components..... Through-current, through-position
- External factors..... Voltage imbalance

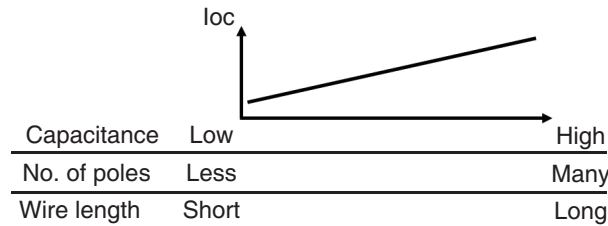

[Effect of residual current]

Another noise component is the residual current* (hereinafter, specified as I_r). I_r increases in proportion to the through-current.

* Residual current

Residual current refers to the error that occurs as a result of an imbalance in the magnetic flux of each phase inside the core due to the arrangement of the through-wire of ZCT.

Errors also occur as a result of the imbalance in the magnetic circuit of ZCT.

I_r combines with i_o , and is output to the secondary side of ZCT. I_r is the same frequency component as i_{or} , and the amount of current or the phase difference with respect to i_{or} changes depending on the through-position of the power line passing through ZCT. Therefore, isolation from i_{or} , which must essentially be detected, becomes difficult.

If the position of ZCT and the through-wire is fixed once, the phase of I_r does not change. Moreover, by fixing the through-wire in the center of ZCT, I_r can be reduced. Fix and install the through-wire in the center as much as possible.

Use the following holder to fix the through-wire in the center of ZCT.

Part name	Manufacturer	Model
Rubber holder	Midori Anzen Co. Ltd.	HZ-25

Effect of voltage imbalance

The ZCT (IRT) calculates the Ior from the phase difference between the measured Ior and the voltage. If there is a voltage imbalance, the phase of each phase voltage will change, and an error will occur in the calculation of Ior. Use the measurement results of the case when the voltage imbalance ratio is within 3%.

Range indicated by the measured value during insulation deterioration

The accuracy of the insulation resistance value is decided under the influence of several parameters. (The parameters are as described on page 16)

An example of the range shown by the measured value as a result of deterioration of the insulation resistance is shown in the figure below. Ioc may further increase depending on the manufacturer and structure of the motor, which may result in a decline in accuracy.

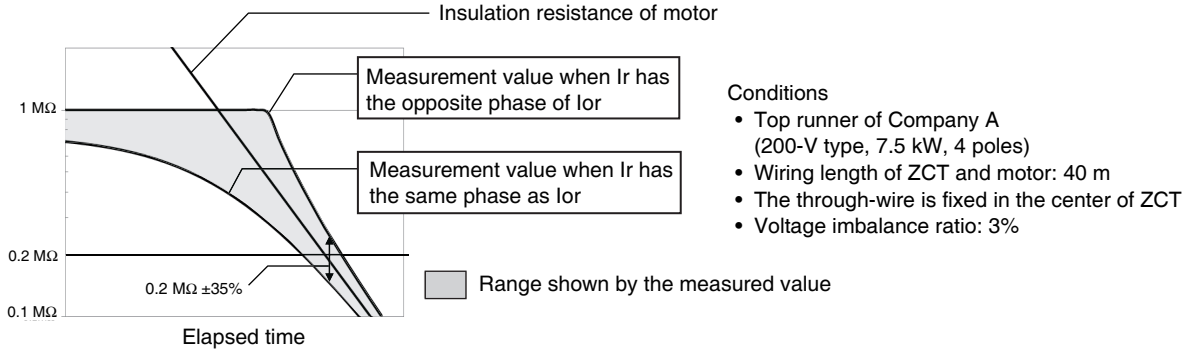

Inverter special measurement

A case is known where a motor is driven by setting the system voltage and inverter to the same frequency. (Ex. System frequency: 60 Hz, inverter frequency: 60 Hz)

In the past, since it was not possible to remove the frequency component of the inverter in such a configuration, it was difficult to measure the insulation resistance.

In the inverter special measurement, the measurement of the insulation resistance is made possible by detecting the minute deviation in frequency. The 60 seconds required as the measurement time is the time for accumulation of the data necessary for this measurement.

Comprehensive Current Diagnosis Type Technical Data (Reference)

Use one CT per motor to detect current flowing into the motor. Select a CT that matches the motor capacity.

CT type	Measurement range	Maximum measurement range	Applicable motor (200 VAC)	Applicable motor (400 VAC)
K6CM-CICB005 5 A	1.00 A to 5.00 A	1.00 A to 5.25 A	0.75 kW	1.5 kW to 2.2 kW
K6CM-CICB025 25 A	5.00 A to 25.00 A	5.00 A to 26.25 A	1.5 kW to 5.5 kW	3.7 kW to 11 kW
K6CM-CICB100 100 A	20 A to 100 A	20 A to 105 A	7.5 kW to 22 kW	15 kW to 45 kW
K6CM-CICB200 200 A	40 A to 200 A	40 A to 210 A	30 kW to 45 kW	55 kW to 90 kW
K6CM-CICB400 400 A	80 A to 400 A	80 A to 420 A	55 kW to 90 kW	110 kW to 200 kW
K6CM-CICB600 600 A	120 A to 600 A	120 A to 630 A	110 kW to 150 kW	250 kW to 300 kW

Note: At no load, the motor current is at approximately half rated load. Select a CT that can cover the range of 50% to 100% of rated current.

Use the following expression when calculating the current value from the motor capacitance.

$$\text{Current value of motor (A)} = \frac{\text{Motor capacitance (kW)} \times 1000}{\text{Motor voltage (V)} \times \sqrt{3} \times \text{Power factor (0.9)} \times \text{Efficiency (0.8)}}$$

(Example) When a 5.5-kW motor is used at 200 V

$$\text{Current value of motor} = \frac{5.5 \times 1000}{200 \times \sqrt{3} \times 0.9 \times 0.8} = 22 \text{ A}$$

Therefore, the CT K6CM-CICB025 in which 22 A is within the measurement range is selected.

The measurement range is within 20 and 100 A even in the case of K6CM-CICB100, which means that 22 A is within the range and this model can also be used. However, during selection, priority must be given to a CT having a small rated current value in order to realize more accurate measurement.

Note: In the expression shown above, general values must be used for the power factor and efficiency, and the load factor must be 100%. However, depending on the actual operating environment, the actual current value and measured value may be different. If the CT is used at a current value that is below the lower-limit value of the measurement range of the CT, the measurement error of the degradation level will increase. Therefore, if possible, measure the current during a steady-state operation with a clamp meter, etc., and select a CT corresponding to the current value.

K6CM

The frequency characteristics of the CT are as indicated below.

K6CM-CICB005 5A

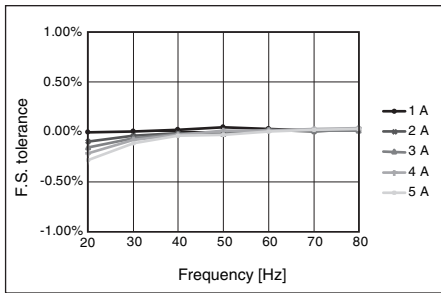

K6CM-CICB025 25A

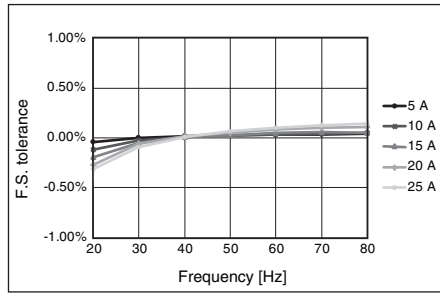

K6CM-CICB100 100A

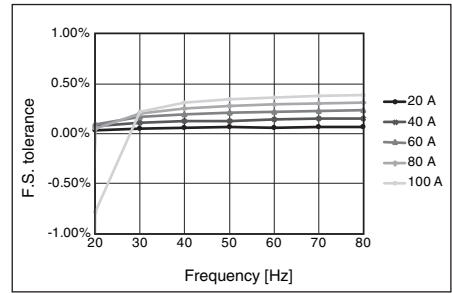

K6CM-CICB200 200A

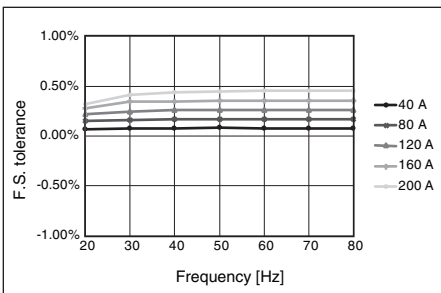

K6CM-CICB400 400A

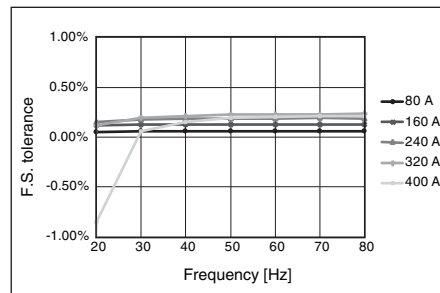

K6CM-CICB600 600A

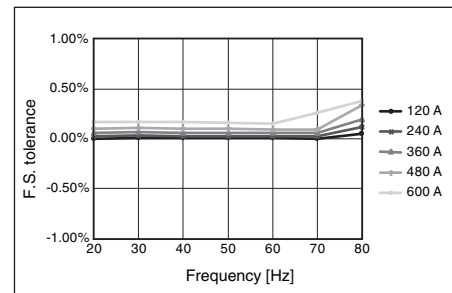

Vibration & Temperature Type: Technical Data

Pairing of sensor head and pre-amplifier

The sensor head and the pre-amplifier are calibrated and inspected as a set at the factory shipment. Be sure to use them with the combination shipped. The sensor head cannot be replaced.

To verify the combination, check the serial numbers on the label of the sensor head and the label of the pre-amplifier. The same serial number means the correct combination.

If you change the combination of factory shipping conditions and then use them, the value of acceleration and the value of velocity will be inconsistent, so measurement cannot be correctly monitored.

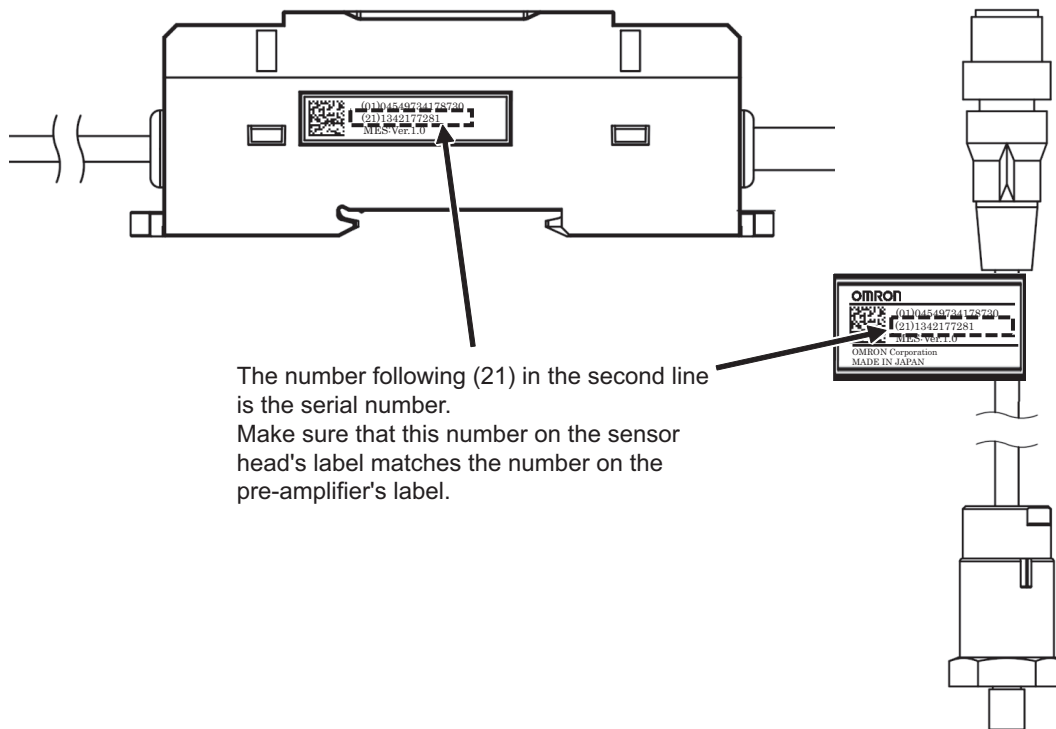

The number following (21) in the second line is the serial number. Make sure that this number on the sensor head's label matches the number on the pre-amplifier's label.

List of Parameters

Setting values

Parameter	Content	Model		
		K6CM -VBM	K6CM -ISM	K6CM -CIM
Acceleration/upper-limit alarm threshold value (Critical and Warning)	0.00 to 99.99 G	●		
Velocity/upper-limit alarm threshold value (Critical and Warning)	0.00 to 99.99 mm/s	●		
Motor temperature/upper-limit alarm threshold value (Critical and Warning)	0 to 9999 deg.	●		
Temperature gap/upper-limit alarm threshold value (Critical and Warning)	0 to 9999 deg.	●		
Insulation resistance/lower-limit alarm threshold value (Critical and Warning)	0.000 to 9.999 MΩ		●	
Degradation level/lower-limit alarm threshold value (Critical and Warning)	0 to 999			●
Current/upper-limit alarm threshold value (Critical and Warning)	CT rating 5 A: 00.00 to 99.99 A CT rating 25 A/100 A/200 A/400 A/600 A: 0.0 to 999.9 A			●
Main unit IP address	Sets the IP address of the main unit. The default value is "192.168.250.10" (common to all models)	●	●	●
Software reset	Restarts the K6CM. Used to enable the settings after changing the setting values. 0 → 1: Execute	●	●	●
MAX/MIN reset	Initializes the MAX/MIN value. 0 → 1: Execute	●	●	●
Display value type	Sets which measurement value to display in the 7-segment display at the front of the main unit. 0: PV (Present Value), 1: MIN, 2: MAX	●	●	●
Trigger mode *1	Sets the trigger mode. 0: At all times, 1: External trigger, 2: Internal trigger	●	●	●
Trigger type	Sets Rise, Fall, or Level in the case of an internal trigger or external trigger. 0: Rise, 1: Fall, 2: Level	●	●	●
Trigger level	Sets the trigger level when "Internal trigger" and the trigger type "Level" have been selected.	●	●	●
Monitoring time	Sets the time for continuing measurement or monitoring in the case of an internal trigger or external trigger, when the trigger type is either Rise or Fall. Setting value: 0.1 to 600.0 s	●	●	●
Alarm latch	Sets whether to enable or disable the alarm latch function. 0: Disable (no latch), 1: Enable (latched)	●	●	●
Use Running Time	Sets whether or not to use the main unit residual amount function. 0: OFF (Do not use), 1: ON (Use)	●	●	●
Moving average times	Performs the averaging process for the past n-times of data including the sampling data of that time, each time sampling of the measurement value is performed. 0: OFF, 1: 2 times, 2: 4 times, 3: 8 times, 4: 16 times, 5: 32 times	●	●	●
Temperature unit	Sets the temperature unit. 0: °C, 1: °F	●		
Circuit topology	Sets the Circuit topology. 0: Three-phase, three-conductor, S-phase ground 1: Three-phase, four-conductor, N-phase ground, load-side Δ connection		●	
Using inverter	Sets the Using inverter. 0: OFF (without inverter), 1: ON (with inverter)		●	
Inverter special measurement	Sets the inverter special measurement. 0: OFF, 1: ON (Refers to the special calculation performed when the inverter frequency and commercial frequency are close.)		●	
Current range	Selects the connected CT. 0: 5 A, 1: 25 A, 2: 100 A, 3: 200 A, 4: 400 A, 5: 600 A			●
Transistor output method *2	0: Normally Closed/1: Normally Open	●	●	●

*1. The external trigger function can be used only when the insulation resistance type is EIP CPU version 1.1 or higher.

*2. Can be used only with EIP CPU version 1.1 or higher.

Measured values / Status data

Parameter	Content	Model		
		K6CM -VBM	K6CM -ISM	K6CM -CIM
Acceleration (Present value, MIN, MAX)	0.00 to 9.99 G	●		
Velocity (Present value, MIN, MAX)	0.00 to 45.00 mm/s	●		
Motor temperature	0 to 80°C (32 to 176°F)	●		
Temperature gap (Difference between motor temperature and room temperature)	0 to 80°C (32 to 176°F)	●		
Acceleration status	Bit 00: Present value measurement status	●		
Velocity status	Bit 01: Present value input error			
Motor temperature status	Bit 04: MAX value measurement status			
Temperature gap status	Bit 05: MAX value input error			
	Bit 08: MIN value measurement status			
	Bit 09: MIN value input error			
	Bit 12: Individual alarm threshold value (Warning) setting			
	Bit 13: Individual alarm threshold value (Critical) setting			
Insulation resistance (Present value, MIN, MAX)	0.000 to 1.000 MΩ		●	
Leakage current Ior (Present value, MIN, MAX)	0.0 to 200.0 mA		●	
Leakage current Ioc (Present value)	0.0 to 200.0 mA		●	
Ior status	Bit 00: Present value measurement status		●	
Ioc status	Bit 01: Present value input error			
	Bit 04: MAX value measurement status			
	Bit 05: MAX value input error			
	Bit 08: MIN value measurement status			
	Bit 09: MIN value input error			
	Bit 12: Individual alarm threshold value (Warning) setting			
	Bit 13: Individual alarm threshold value (Critical) setting			
Degradation level (Present value, MIN, MAX)	Degradation level of the motor calculated by measuring the current including the high-frequency component. 0 to 999			●
Current (Present value, MIN, MAX)	10 to 100% of the rated value			●
Degradation level status	Bit 00: Present value measurement status			●
Current value status	Bit 01: Present value input error			
	Bit 04: MAX value measurement status			
	Bit 05: MAX value input error			
	Bit 08: MIN value measurement status			
	Bit 09: MIN value input error			
	Bit 12: Individual alarm threshold value (Warning) setting			
	Bit 13: Individual alarm threshold value (Critical) setting			
Measurement CPU version	Measurement unit version	●	●	●
Main CPU version	Main unit version	●	●	●
EIP CPU version	EtherNet/IP unit version	●	●	●
Measurement status	1: Measurement/monitoring in progress, 0: Measurement/monitoring stopped	●	●	●
Running time status	The product of the operation time and internal temperature is integrated, and ON is set if it reaches the design life. 1: Reached (Operation integration has reached 100%) 0: Not reached (Operation integration has not reached 100%)	●	●	●
Trigger input	Status of external trigger input. 1: ON, 0: OFF	●	●	●
TR1 (Transistor 1 output status)	Status of transistor 1. 1: ON, 0: OFF	●	●	●
TR2 (Transistor 2 output status)	Status of transistor 2. 1: ON, 0: OFF	●	●	●
TR3 (Transistor 3 output status)	Status of transistor 3. 1: ON, 0: OFF	●	●	●
Running time	Coefficient showing the extent of life of the main unit based on the product of the operation time and internal temperature. Incremented in units of 10% starting from 0%. 0000 hex to 0064 hex (0 to 100)	●	●	●

Parameter	Content	Model		
		K6CM -VBM	K6CM -ISM	K6CM -CIM
Trigger frequency	Total integrated number of external triggers and internal triggers. Incremented by 1 after every 100 times. 0 to 65535	●	●	●
Threshold value setting of integrated alarm (Warning)	State when the measurement value is "Warning".	●	●	●
Threshold value setting of integrated alarm (Critical)	State when the measurement value is "Critical".	●	●	●
Acceleration/upper-limit alarm (Critical and Warning)	ON, OFF	●		
Velocity/upper-limit alarm (Critical and Warning)	ON, OFF	●		
Motor temperature/upper-limit alarm (Critical and Warning)	ON, OFF	●		
Temperature gap/upper-limit alarm (Critical and Warning)	ON, OFF	●		
Insulation resistance/lower-limit alarm (Critical and Warning)	ON, OFF		●	
Degradation level/lower-limit alarm (Critical and Warning)	ON, OFF			●
Current/upper-limit alarm (Critical and Warning)	ON, OFF			●

OMRON AUTOMATION AMERICAS HEADQUARTERS • Chicago, IL USA • 847.843.7900 • 800.556.6766 • www.omron247.com

OMRON CANADA, INC. • HEAD OFFICE

Toronto, ON, Canada • 416.286.6465 • 866.986.6766 • www.omron247.com

OMRON ELECTRONICS DE MEXICO • HEAD OFFICE

México DF • 52.55.59.01.43.00 • 01-800-226-6766 • mela@omron.com

OMRON ELECTRONICS DE MEXICO • SALES OFFICE

Apodaca, N.L. • 52.81.11.56.99.20 • 01-800-226-6766 • mela@omron.com

OMRON ELETRÔNICA DO BRASIL LTDA • HEAD OFFICE

São Paulo, SP, Brasil • 55.11.2101.6300 • www.omron.com.br

OMRON ARGENTINA • SALES OFFICE

Cono Sur • 54.11.4783.5300

OMRON CHILE • SALES OFFICE

Santiago • 56.9.9917.3920

OTHER OMRON LATIN AMERICA SALES

54.11.4783.5300

OMRON EUROPE B.V. • Wegalaan 67-69, NL-2132 JD, Hoofddorp, The Netherlands. • +31 (0) 23 568 13 00 • www.industrial.omron.eu

Authorized Distributor:

Controllers & I/O

- Machine Automation Controllers (MAC) • Motion Controllers
- Programmable Logic Controllers (PLC) • Temperature Controllers • Remote I/O

Robotics

- Industrial Robots • Mobile Robots

Operator Interfaces

- Human Machine Interface (HMI)

Motion & Drives

- Machine Automation Controllers (MAC) • Motion Controllers • Servo Systems
- Frequency Inverters

Vision, Measurement & Identification

- Vision Sensors & Systems • Measurement Sensors • Auto Identification Systems

Sensing

- Photoelectric Sensors • Fiber-Optic Sensors • Proximity Sensors
- Rotary Encoders • Ultrasonic Sensors

Safety

- Safety Light Curtains • Safety Laser Scanners • Programmable Safety Systems
- Safety Mats and Edges • Safety Door Switches • Emergency Stop Devices
- Safety Switches & Operator Controls • Safety Monitoring/Force-guided Relays

Control Components

- Power Supplies • Timers • Counters • Programmable Relays
- Digital Panel Meters • Monitoring Products

Switches & Relays

- Limit Switches • Pushbutton Switches • Electromechanical Relays
- Solid State Relays

Software

- Programming & Configuration • Runtime

X-ON Electronics

Largest Supplier of Electrical and Electronic Components

Click to view similar products for [Interface Modules](#) category:

Click to view products by [Omron](#) manufacturer:

Other Similar products are found below :

[IFD8520](#) [cPCI-3544](#) [422CON](#) [ATX6022/14GP7](#) [ATX6022/8](#) [FC6A-EXM2](#) [OPT8AP-AE](#) [60006-016](#) [96RMKVM-19V1C-A](#) [60016-011](#)
[60016-014](#) [60006-008](#) [60016-015](#) [60011-075](#) [HPCI-14S12U](#) [cBP-3208](#) [cBP-3062A](#) [FAB205-6P5](#) [ATX6022/6](#) [60016-012](#) [96RMKVM-](#)
[17V1C-A](#) [PCE-DP10-00A1E](#) [MOS-1120Y-0201E](#) [96RMLCD-17V1-A](#) [96RMKVM-17V8C-A](#) [60004-005](#) [60016-017](#) [60006-019](#) [60006-009](#)
[60016-035](#) [60016-034](#) [60016-031](#) [60016-030](#) [60016-026](#) [60016-025](#) [60016-024](#) [60016-021](#) [60016-018](#) [60016-007](#) [60016-006](#) [60016-005](#)
[60016-004](#) [60007-002](#) [60006-018](#) [60006-010](#) [AXX10GBTWLHW3](#) [382-BBEH](#) [555-BDCL](#) [GW DEVICE SERVER 2E/4DB9](#)
[K6CMISZBI52](#)