

Multi-function Compact Inverter

MX2-Series V1 type

Born to drive machines



- » Permanent magnet motors
- » Drive Programming
- » Built-in safety

Harmonised motor and machine control

MOTOR CONTROL

200% starting torque

- Near stand-still operation (0.5 Hz)
- Smooth control of high inertia loads
- Control of fast cyclic loads

Torque control in open loop

- Ideal for low to medium torque applications
- Can replace a flux vector or servo drive in suitable systems

Motor control

- Surface Permanent Magnet Motor
- Interior Permanent Magnet Motor
- Induction Motor

One parameter auto-tuning

- Just by entering the kW rating of the motor the MX2-V1 gives you smooth and safe operation



MACHINE CONTROL

Safety inside

- Conforms to safety norm ISO 13849-1 Cat. 3 performance level PLd
- 2 Safety inputs
- External device monitoring (EDM)

Drive Programming

- Flow chart programming
- Text editor
- Intuitive - up to 5 tasks in parallel

Positioning

- Up to 8 pre-set positions with "Homing"
- Speed synchronisation

Network Integration

- Modbus RS485 built-in
- Option units for EtherCAT, CompoNet, DeviceNet

危険 一ツが、感電のおそれがあります。
WARNING - Risk of electric shock.
• 点検、修理の前には必ず取扱説明書をお読み下さい。
• 点検中及び修理直後10分以内はフロントカバーを外さないで下さい。
• Wait 10 minutes for capacitor discharge after disconnecting power supply.

Amazing in Control

High starting torque and torque control capability in open loop mode give you full control of your machine dynamics and performance. Options for all of the major open network systems.

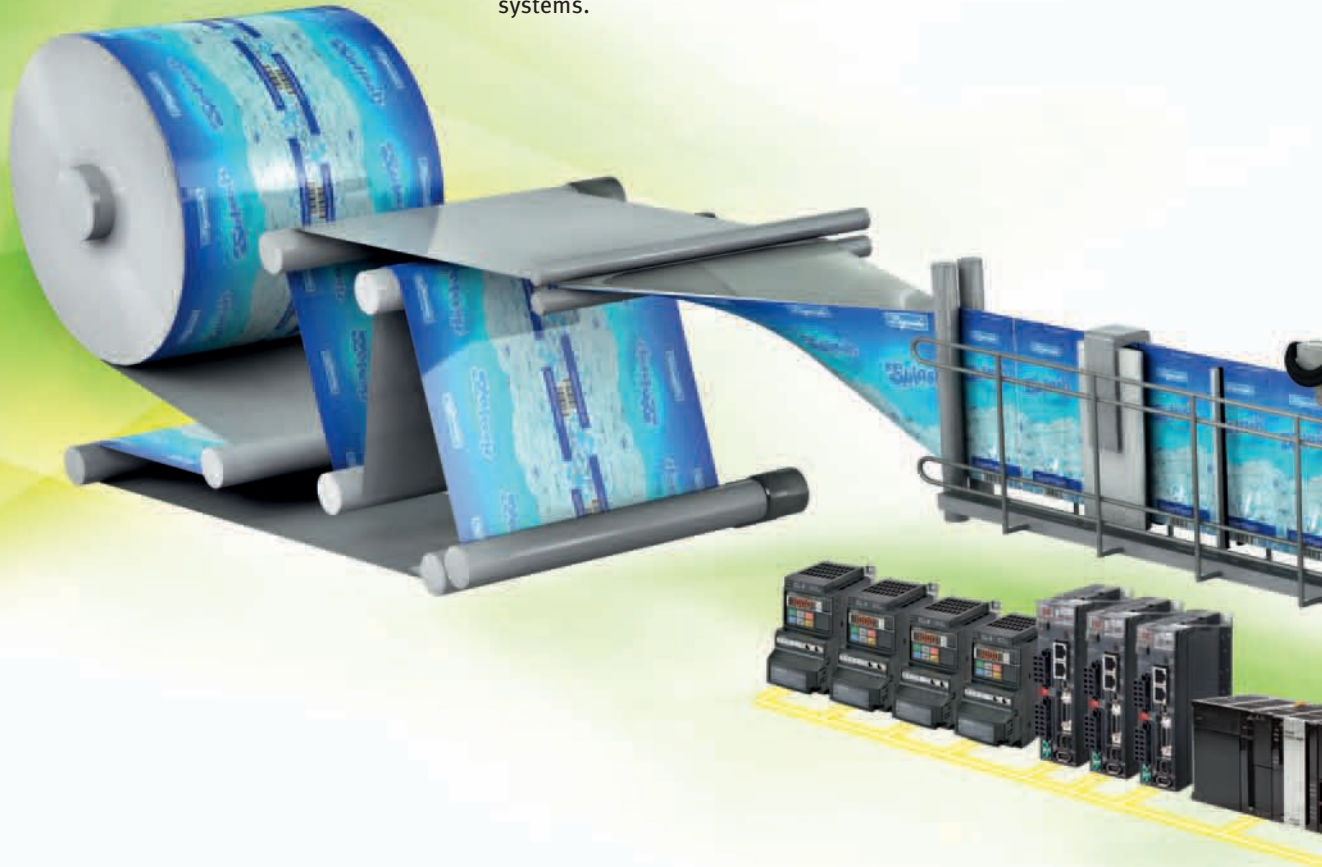

Torque master

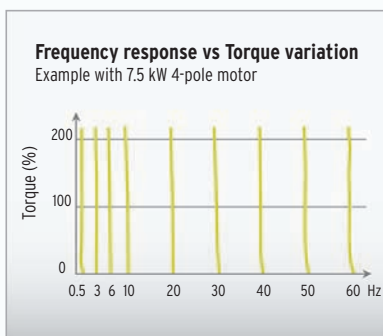

The MX2-V1 delivers 200% starting torque near stand-still (0.5 Hz) and can operate in torque control in open loop mode. This allows the MX2-V1 to be used in applications where closed loop AC vector drives were previously used.

Easy network integration



Standard industrial networks, such as EtherCAT, CompoNet or DeviceNet as options. High-speed EtherCAT provides solutions for the entire system from input to output with Sysmac Series.

Easy communications setting

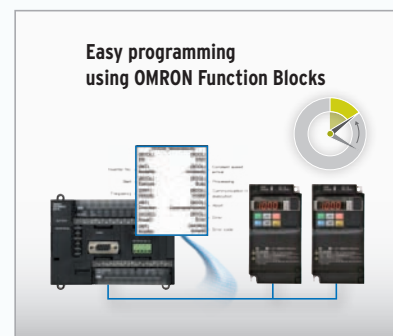

Built-in RS-485 Modbus communications. OMRON Function Blocks are available for the CP H/L and CJ-series PLCs. Those control the MX2-V1 via Modbus communications easily.

Safety in Control

Safety is embedded in the MX2-V1, according to ISO 13849-1, Cat. 3, with two safety inputs and an External Device Monitoring (EDM) output.

No external contactors on the motor side are required, meaning simpler wiring for the user.



**Safety embedded;
ISO 13849-1, Cat. 3**

**MOTOR CONTROL
Permanent magnet motors**

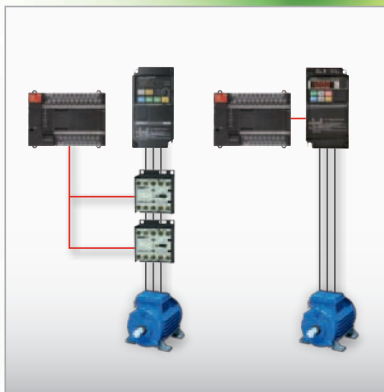

Dual contactors at the output of the inverter are no longer required. Direct connection to a safety controller ensures compliance to ISO 13849-1, Cat. 3.



The PM motor conforming to high-efficiency regulations can be controlled. The PM motor promotes further energy saving and achieves earth-friendly machine control.

Position and run!

The MX2-V1 is a drive and position controller in one, ideal for modular machines where moderate positional accuracy is required. Speed synchronisation is also possible, with no additional programming required.

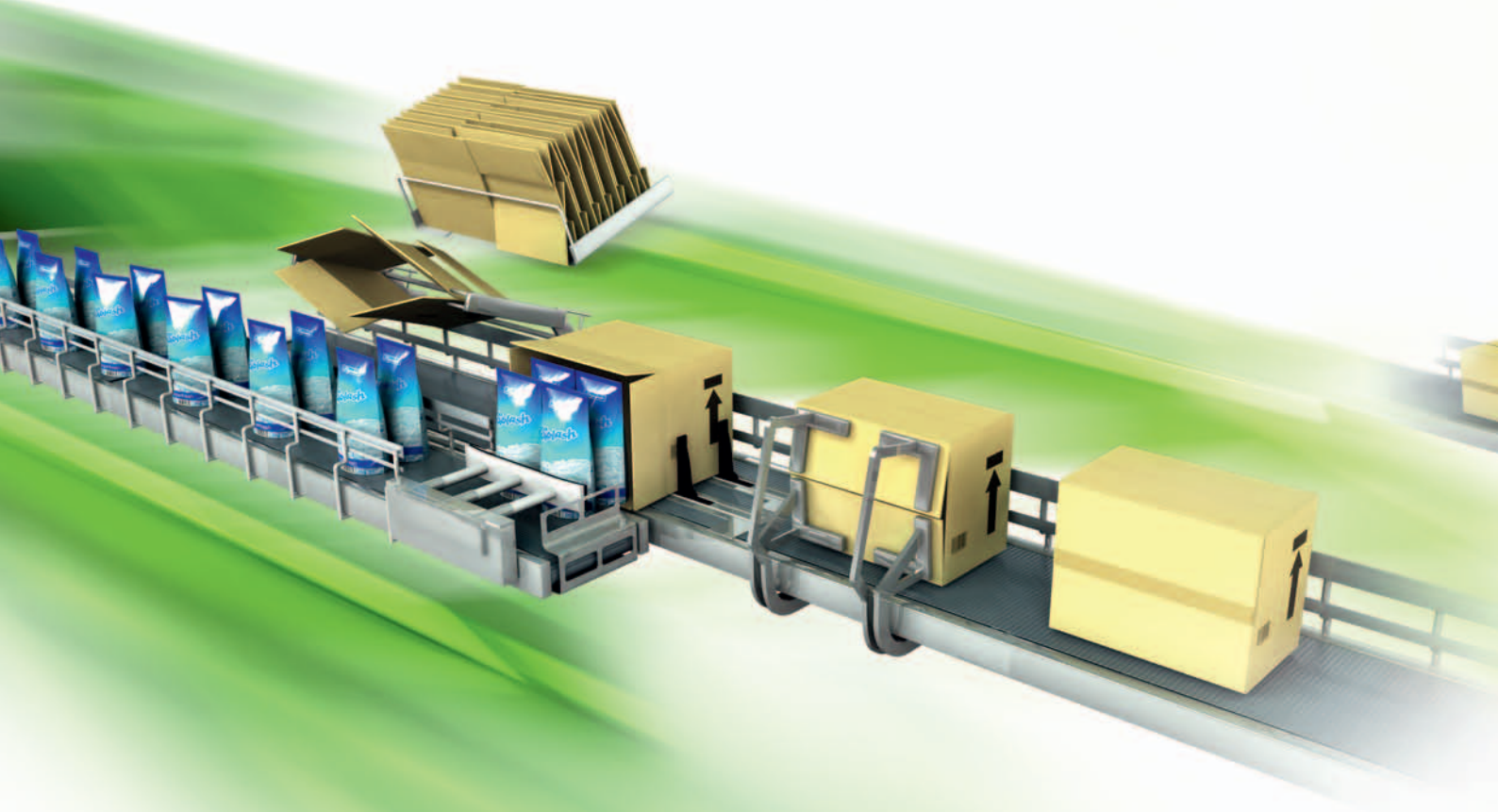

Speed synchronisation



With no external hardware required, and via standard parameter settings, speed synchronisation can be achieved. The MX2-V1 will act as a speed follower to an external pulse generator/encoder signal up to 32 KHz.

Positioning functionality



Specially developed application functionality enables the MX2-V1 to solve simple positioning tasks without the need for an external controller. Up to 8 positions, plus home, can be selected by the user, and furthermore, the MX2-V1 can be switched between speed and position mode.

Program and play!

The MX2-V1 gives you the power to create smart solutions using PLC functionality, as standard. Via an intuitive flow chart programming tool, you can create programs with up to 1000 lines of code and with 5 tasks running in parallel.

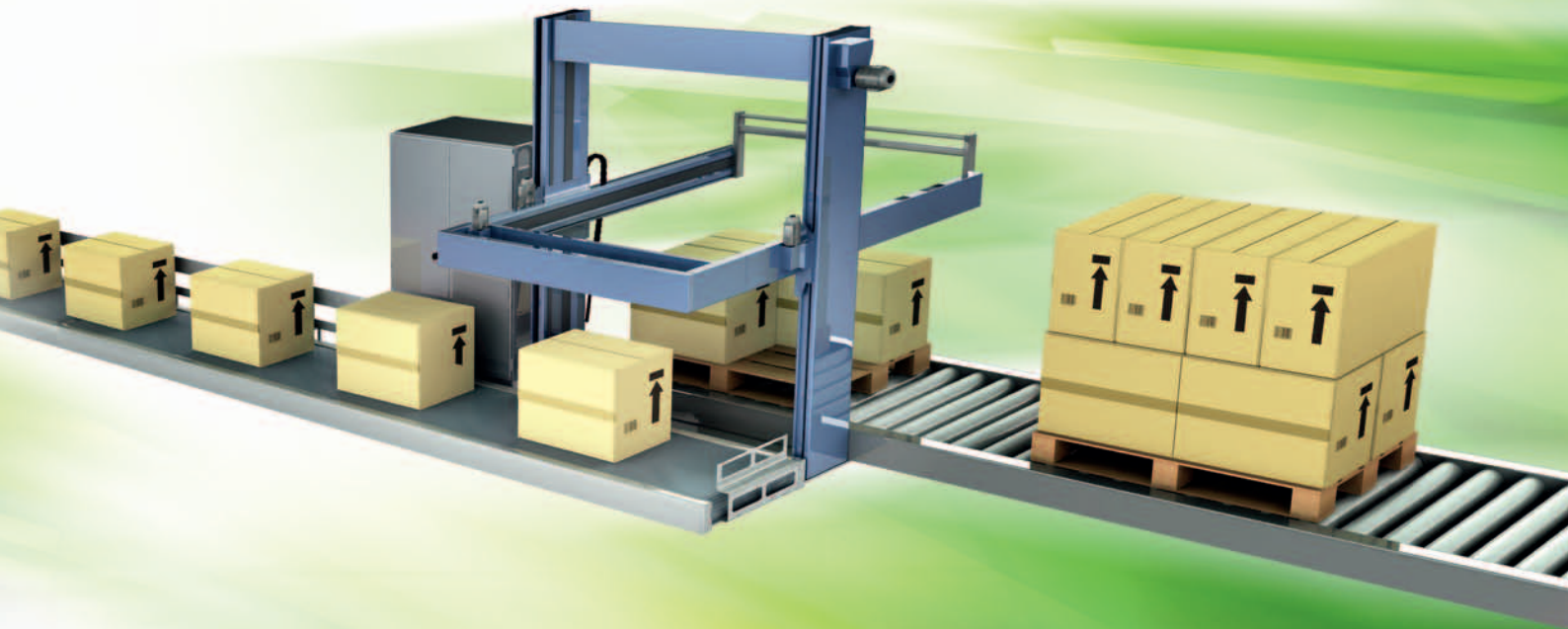

Free to program



- Intuitive and user friendly flow chart programming
- Integrated in CX-Drive
- Up to 1000 lines in a program
- 5 tasks can run in parallel
(CX-Drive version 2.80 or higher is required.)

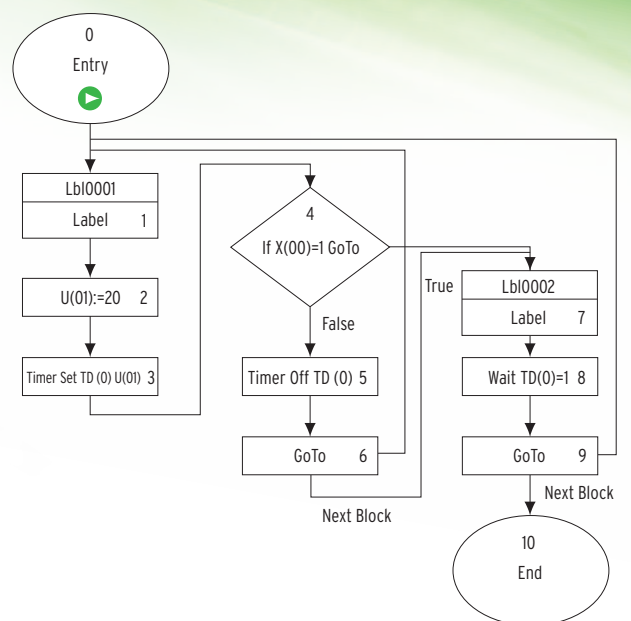

MX2-Series V1 type

Born to drive machines

- Positioning functionality.
- Fieldbus communications with optional unit
EtherCAT, CompoNet and DeviceNet
- Drive Programming.
- Current vector Control.
- High Starting torque: 200% at 0.5 Hz.
- Safety function * EN ISO 13849-1:2008 (Cat.3/PLd)
IEC 60204-1 Stop Category 0
- Speed range up to 580 Hz.

* When optional DeviceNet communication unit or CompoNet communication unit is mounted onto the MX2-series V1 type, the inverter will not conform to the safety standards.



Performance Specifications

Inverter MX2-series V1 type

3-phase 200 V Class

Function name			3-phase 200 V										
Model name (3G3MX2-)			A2001-V1	A2002-V1	A2004-V1	A2007-V1	A2015-V1	A2022-V1	A2037-V1	A2055-V1	A2075-V1	A2110-V1	A2150-V1
Applicable motor capacity	kW	CT	0.1	0.2	0.4	0.75	1.5	2.2	3.7	5.5	7.5	11	15
		VT	0.2	0.4	0.75	1.1	2.2	3.0	5.5	7.5	11	15	18.5
	HP	CT	1/8	1/4	1/2	1	2	3	5	7 1/2	10	15	20
		VT	1/4	1/2	1	1 1/2	3	4	7 1/2	10	15	20	25
Rated output capacity [kVA]	200 V	CT	0.2	0.5	1.0	1.7	2.7	3.8	6.0	8.6	11.4	16.2	20.7
		VT	0.4	0.6	1.2	2.0	3.3	4.1	6.7	10.3	13.8	19.3	23.9
	240 V	CT	0.3	0.6	1.2	2.0	3.3	4.5	7.2	10.3	13.7	19.5	24.9
		VT	0.4	0.7	1.4	2.4	3.9	4.9	8.1	12.4	16.6	23.2	28.6
Rated input voltage			3-phase 200 V - 15% to 240 V + 10%, 50/60 Hz ± 5%										
Rated input current [A]	CT		1.0	1.6	3.3	6.0	9.0	12.7	20.5	30.8	39.6	57.1	62.6
	VT		1.2	1.9	3.9	7.2	10.8	13.9	23.0	37.0	48.0	68.0	72.0
Rated output voltage			3-phase 200 to 240 V (The output cannot exceed the incoming voltage).										
Rated output current [A]	CT		1.0	1.6	3.0	5.0	8.0	11.0	17.5	25.0	33.0	47.0	60.0
	VT		1.2	1.9	3.5	6.0	9.6	12.0	19.6	30.0	40.0	56.0	69.0
Short-time deceleration braking torque (%) (Discharge Resistor not connected)			50	50	50	50	50	20	20	20	20	10	10
Braking Resistor circuit *	Regenerative braking		Built-in Braking Resistor circuit (separate Discharge Resistor)										
	Min. connectable resistance [Ω]		100	100	100	50	50	35	35	20	17	17	10
Weight [kg]			1.0	1.0	1.1	1.2	1.6	1.8	2.0	3.3	3.4	5.1	7.4
Dimensions (width × height) [mm]			68 × 128			108 × 128		140 × 128	140 × 260		180 × 296	220 × 350	
Dimensions (depth) [mm]			109		122.5	145.5	170.5		170.5	155		175	

* The BRD usage is 10%.

3-phase 400 V Class

Function name			3-phase 400 V									
Model name (3G3MX2-)			A4004-V1	A4007-V1	A4015-V1	A4022-V1	A4030-V1	A4040-V1	A4055-V1	A4075-V1	A4110-V1	A4150-V1
Applicable motor capacity	kW	CT	0.4	0.75	1.5	2.2	3.0	4.0	5.5	7.5	11	15
		VT	0.75	1.5	2.2	3.0	4.0	5.5	7.5	11	15	18.5
	HP	CT	1/2	1	2	3	4	5	7 1/2	10	15	20
		VT	1	2	3	4	5	7 1/2	10	15	20	25
Rated output capacity [kVA]	380 V	CT	1.1	2.2	3.1	3.6	4.7	6.0	9.7	11.8	15.7	20.4
		VT	1.3	2.6	3.5	4.5	5.7	7.3	11.5	15.1	20.4	25.0
	480 V	CT	1.4	2.8	3.9	4.5	5.9	7.6	12.3	14.9	19.9	25.7
		VT	1.7	3.4	4.4	5.7	7.3	9.2	14.5	19.1	25.7	31.5
Rated input voltage			3-phase 380 V - 15% to 480 V + 10%, 50/60 Hz ± 5%									
Rated input current [A]	CT		1.8	3.6	5.2	6.5	7.7	11.0	16.9	18.8	29.4	35.9
	VT		2.1	4.3	5.9	8.1	9.4	13.3	20.0	24.0	38.0	44.0
Rated output voltage			3-phase 380 to 480 V (The output cannot exceed the incoming voltage).									
Rated output current [A]	CT		1.8	3.4	4.8	5.5	7.2	9.2	14.8	18.0	24.0	31.0
	VT		2.1	4.1	5.4	6.9	8.8	11.1	17.5	23.0	31.0	38.0
Short-time deceleration braking torque (%) (Discharge Resistor not connected)			50	50	50	20	20	20	20	20	10	10
Braking Resistor circuit *	Regenerative braking		Built-in Braking Resistor circuit (separate Discharge Resistor)									
	Min. connectable resistance [Ω]		180	180	180	100	100	100	70	70	70	35
Weight [kg]			1.5	1.6	1.8	1.9	1.9	2.1	3.5	3.5	4.7	5.2
Dimensions (width × height) [mm]			108 × 128				140 × 128	140 × 260			180 × 296	
Dimensions (depth) [mm]			143.5	170.5			170.5	155		175		

* The BRD usage is 10%.

1-phase 200 V Class

Function name			1-phase 200 V					
Model name (3G3MX2-)			AB001-V1	AB002-V1	AB004-V1	AB007-V1	AB015-V1	AB022-V1
Applicable motor capacity	kW	CT	0.1	0.2	0.4	0.75	1.5	2.2
		VT	0.2	0.4	0.55	1.1	2.2	3.0
	HP	CT	1/8	1/4	1/2	1	2	3
		VT	1/4	1/2	3/4	1 1/2	3	4
Rated output capacity [kVA]	200 V	CT	0.2	0.5	1.0	1.7	2.7	3.8
		VT	0.4	0.6	1.2	2.0	3.3	4.1
	240 V	CT	0.3	0.6	1.2	2.0	3.3	4.5
		VT	0.4	0.7	1.4	2.4	3.9	4.9
Rated input voltage			1-phase 200 V - 15% to 240 V + 10%, 50/60 Hz ± 5%					
Rated input current [A]	CT		1.3	3.0	6.3	11.5	16.8	22.0
	VT		2.0	3.6	7.3	13.8	20.2	24.0
Rated output voltage			3-phase 200 to 240 V (The output cannot exceed the incoming voltage).					
Rated output current [A]	CT		1.0	1.6	3.0	5.0	8.0	11.0
	VT		1.2	1.9	3.5	6.0	9.6	12.0
Short-time deceleration braking torque (%) (Discharge Resistor not connected)			50	50	50	50	50	20
Braking Resistor circuit *	Regenerative braking		Built-in Braking Resistor circuit (separate Discharge Resistor)					
	Min. connectable resistance [Ω]		100	100	100	50	50	35
Weight [kg]			1.0	1.0	1.1	1.4	1.8	1.8
Dimensions (width × height) [mm]			68 × 128			108 × 128		
Dimensions (depth) [mm]			109		122.5	170.5		

* The BRD usage is 10%.

Multi-function Compact Inverter **MX2-Series V1 type**

Function Specifications

Function name		Specifications
Enclosure ratings *1		Open type (IP20)
Control	Control method	Phase-to-phase sinusoidal modulation PWM
	Output frequency range *2	0.10 to 400 Hz (or 580 Hz in the high-frequency mode; restrictions apply)
	Frequency precision *3	Digital command: $\pm 0.01\%$ of the max. frequency, Analog command: $\pm 0.2\%$ of the max. frequency ($25 \pm 10^\circ\text{C}$)
	Frequency setting resolution	Digital setting: 0.01 Hz, Analog setting: One-thousandth of the maximum frequency
	Voltage/Frequency characteristics	V/f characteristics (constant/reduced torque) Sensorless vector control, V/f control with speed feedback
	Overload current rating	Heavy load rating (CT): 150%/60 s Light load rating (VT): 120%/60 s
	Instantaneous overcurrent protection	200% of the value of heavy load rating (CT)
	Acceleration/Deceleration time	0.01 to 3600 s (linear/curve selection), acceleration/deceleration 2 setting available
	Carrier frequency adjustment range	2 to 15 kHz (with derating)
	Starting torque	200%/0.5 Hz (sensorless vector control)
	External DC injection braking	Starts at a frequency lower than that in deceleration via the STOP command, at a value set lower than that during operation, or via an external input. (Level and time settable).
Protective functions		Overcurrent, overvoltage, undervoltage, electronic thermal, temperature error, ground fault overcurrent at power-on status, rush current prevention circuit, overload limit, incoming overvoltage, external trip, memory error, CPU error, USP error, communication error, overvoltage suppression during deceleration, protection upon momentary power outage, emergency cutoff, etc.
Input signal	Frequency settings	Digital Operator External analog input signal: 0 to 10 VDC/4 to 20 mA, Modbus communication (Modbus-RTU)
	RUN/STOP command	Digital Operator External digital input signal (3-wire input supported), Modbus communication (Modbus-RTU)
	Multi-function input	7 points (Selectable from 59 functions)
	Analog input	2 points (Voltage FV terminal: 10 bits/0 to 10 V, Current FI terminal: 10 bits/4 to 20 mA)
	Pulse input	1 point (RP terminal: 32 kHz max., 5 to 24 VDC)
Output signal	Multi-function output	2 points (P1/EDM, P2; selectable from 43 functions)
	Relay output	1 point (1c contact: MC, MA, MB; selectable from 43 functions)
	Analog output (Frequency monitor)	1 point (AM terminal: Voltage 10 bits/0 to 10 V) (Frequency, current selectable)
	Pulse output	1 point (MP terminal: 32 kHz max., 0 to 10 V)
Communications	RS-422	RJ45 connector (for Digital Operator)
	RS-485	Control circuit terminal block, Modbus communication (Modbus-RTU)
	USB	USB1.1, mini-B connector
Drive Programming *4		Calculate, Logic, Control I/O and so on
Other functions		AVR function, V/f characteristics switching, upper/lower limit, 16-step speeds, starting frequency adjustment, jogging operation, carrier frequency adjustment, PID control, frequency jump, analog gain/bias adjustment, S shape acceleration/deceleration, electronic thermal characteristics, level adjustment, restart function, torque boost function, fault monitor, soft lock function, frequency conversion display, USP function, motor 2 control function, UP/DWN, overcurrent control function, etc.
Operating environment	Ambient operating temperature	-10 to 50°C (However, derating is required).
	Ambient storage temperature	-20°C to 65°C
	Ambient operating humidity	20% to 90% RH (with no condensation)
	Vibration resistance	5.9 m/s ² (0.6G), 10 to 55 Hz
	Application environment	At a maximum altitude of 1,000 m; indoors (without corrosive gases or dust)
Options	EtherCAT Communication Unit	3G3AX-MX2-ECT
	CompoNet Communication Unit	3G3AX-MX2-CRT-E
	DeviceNet Communication Unit	3G3AX-MX2-DRT-E

Function name		Specifications	
Other option		DC reactor, AC reactor, radio noise filter, input noise filter, output noise filter, regenerative braking unit, Braking Resistor, etc.	
International standard	EC directive	EMC directive	EN61800-3: 2004
		Low voltage directive	EN61800-5-1: 2007
		Machinery directives	IEC 60204-1 Stop Category 0, EN IEC 61800-5-2 (STO), EN ISO 13849-1: 2008 (PLd)
	UL/cUL		UL508C

*1 Protection method complies with JEM 1030.

*2 To operate the motor at over 50/60 Hz, contact the motor manufacturer to find out the maximum allowable speed of revolution.

*3 For the stable control of the motor, the output frequency may exceed the maximum frequency set in A004 (A204) by 2 Hz max.

*4 Refer to the Drive Programming USER'S MANUAL (No. I580).

Note:

1. The applicable motor is a 3-phase standard motor. For using any other type, be sure that the rated current does not exceed that of the Inverter.
2. Output voltage decreases according to the level of the power supply voltage.
3. The braking torque at the time of capacitor feedback is an average deceleration torque at the shortest deceleration (when it stops from 50 Hz). It is not a continuous regeneration torque. Also, the average deceleration torque varies depending on the motor loss. The value is reduced in operation over 50 Hz.

Multi-function Compact Inverter MX2-Series V1 type

Components and Functions

Inverter MX2-series V1 type

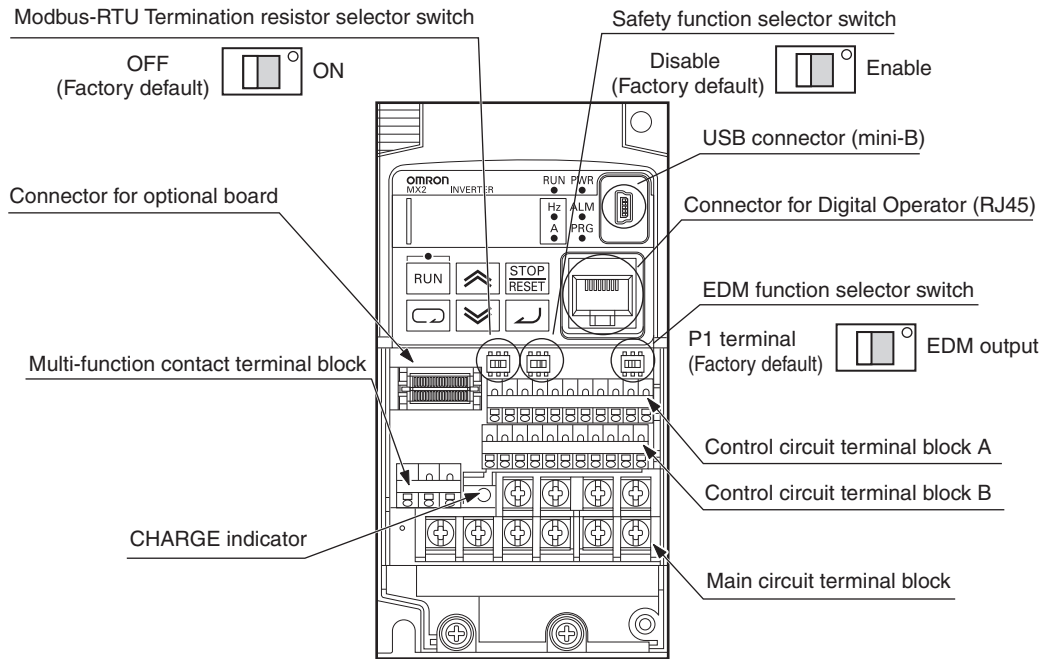

Name	Function
Modbus-RTU Termination resistor selector switch	Use this Terminal Resistor selector switch for RS-485 terminals on the control circuit terminal block. When this switch is turned ON, the internal 200 Ω Resistor is connected.
Safety function selector switch	Turn this switch ON when using the safety function. Turn OFF the power before turning this switch ON/OFF. For details, refer to USER'S MANUAL (Cat.No.I585).
EDM function selector switch	Turn this switch ON when using the EDM output of the safety function. Turn OFF the power before turning this switch ON/OFF. For details, refer to USER'S MANUAL (Cat.No.I585).
USB connector	Use this mini-B USB connector to connect a PC. Even when the Inverter is being operated by a PC, etc., via USB connection, it can still be operated using the Digital Operator.
Connector for Digital Operator	Use this connector to connect the Digital Operator.
Connector for optional board	Use this connector to mount the optional board. (Communications Units and other options can be connected.)
Control circuit terminal blocks A and B	These terminal blocks are used to connect various digital/analog input and output signals for inverter control, etc.
Multi-function contact terminal block	Use this SPDT contact terminal block for relay outputs.
Main circuit terminal block	Use this terminal block to connect an output to the motor and Braking Resistor, etc. Also, use this terminal block to connect the inverter to the main power supply.
CHARGE indicator (Charge indicator LED)	This LED indicator is lit if the DC voltage of the main circuit (between terminals P/+2 and N/-) remains approx. 45 V or above after the power has been cut off. Before wiring, etc. confirm that the Charge LED indicator is turned OFF.

Note: This illustration shows the terminal block with the front cover removed.

Multi-function Compact Inverter MX2-Series V1 type

3G3MX2-AB007-V1
3G3MX2-AB015-V1
3G3MX2-AB022-V1
3G3MX2-A2015-V1
3G3MX2-A2022-V1
3G3MX2-A4004-V1
3G3MX2-A4007-V1
3G3MX2-A4015-V1
3G3MX2-A4022-V1
3G3MX2-A4030-V1

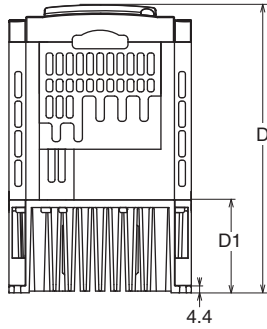
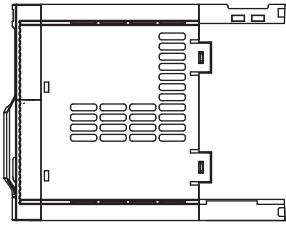
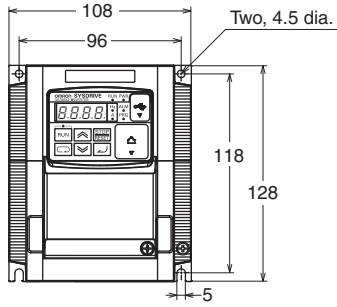

Power supply	Model	W [mm]	H [mm]	D [mm]	D1 [mm]
1-phase 200 V	3G3MX2-AB007-V1	108	128	170.5	55
	3G3MX2-AB015-V1				
	3G3MX2-AB022-V1				
3-phase 200 V	3G3MX2-A2015-V1				
	3G3MX2-A2022-V1				
	3G3MX2-A4004-V1			143.5	28
3-phase 400 V	3G3MX2-A4007-V1	170.5	55		
	3G3MX2-A4015-V1				
	3G3MX2-A4022-V1				
	3G3MX2-A4030-V1				

3G3MX2-A2037-V1
3G3MX2-A4040-V1

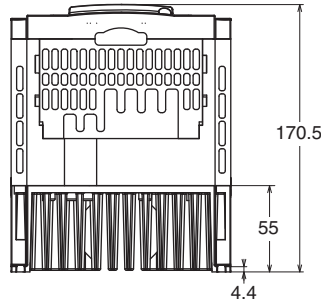
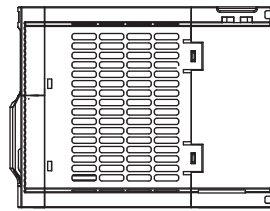
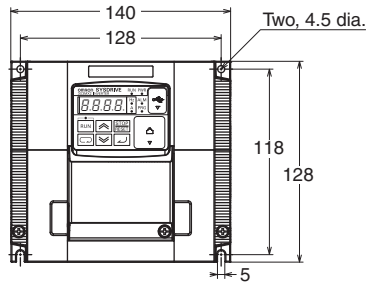

Power supply	Model	W [mm]	H [mm]	D [mm]	D1 [mm]
3-phase 200 V	3G3MX2-A2037-V1	140	128	170.5	55
3-phase 400 V	3G3MX2-A4040-V1				

3G3MX2-A2055-V1
3G3MX2-A2075-V1
3G3MX2-A4055-V1
3G3MX2-A4075-V1

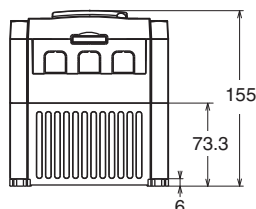
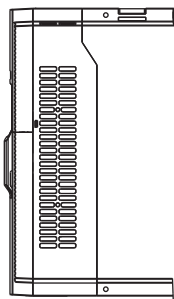
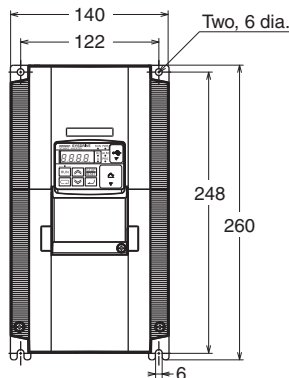

Power supply	Model	W [mm]	H [mm]	D [mm]	D1 [mm]
3-phase 200 V	3G3MX2-A2055-V1	140	260	155	73.3
	3G3MX2-A2075-V1				
3-phase 400 V	3G3MX2-A4055-V1				
	3G3MX2-A4075-V1				

3G3MX2-A2110-V1
3G3MX2-A4110-V1
3G3MX2-A4150-V1

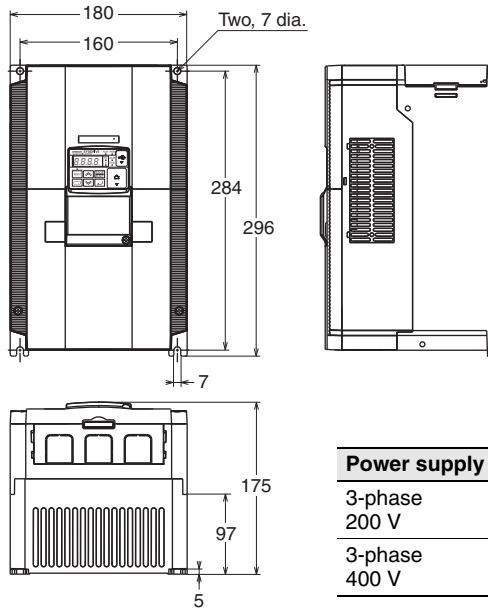

Power supply	Model	W [mm]	H [mm]	D [mm]	D1 [mm]
3-phase 200 V	3G3MX2-A2110-V1	180	296	175	97
3-phase 400 V	3G3MX2-A4110-V1				
	3G3MX2-A4150-V1				

3G3MX2-A2150-V1

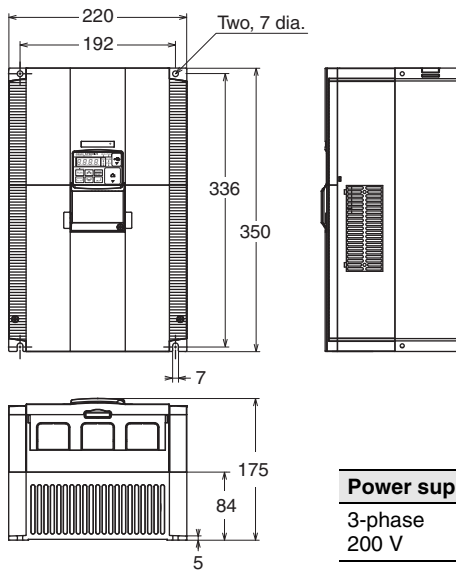

Power supply	Model	W [mm]	H [mm]	D [mm]	D1 [mm]
3-phase 200 V	3G3MX2-A2150-V1	220	350	175	84

Communication Unit

MX2-Series EtherCAT Communication Unit 3G3AX-MX2-ECT

This is the communication unit to connect the Multi-function Compact Inverter MX2 to EtherCAT network.
This communication unit passed the conformance test of EtherCAT.

Common Specifications

Item	Specifications	
Power supply	Supplied from the inverter	
Protective structure	Open type (IP20)	
Ambient operating temperature	-10 to +50°C	
Ambient storage temperature	-20 to +65°C	
Ambient operating humidity	20% to 90% RH (with no condensation)	
Vibration resistance	5.9 m/s ² (0.6 G), 10 to 55 Hz	
Application environment	At a maximum altitude of 1,000 m; indoors (without corrosive gases or dust)	
Weight	100 g max.	
International standard	UL/cUL	UL508C
	EC directive	EMC Directive :EN61800-3: 2004 Low Voltage Directive :EN61800-5-1: 2003

Multi-function Compact Inverter MX2-Series V1 type

EtherCAT Communications Specifications

Item	Specifications
Communications standard	IEC 61158 Type12, IEC 61800-7 CiA 402 drive profile
Physical layer	100BASE-TX (IEEE802.3)
Connector	RJ45 × 2 (shielded type) ECAT IN : EtherCAT input ECAT OUT : EtherCAT output
Communications media	Category 5 or higher (cable with double, aluminum tape and braided shielding) is recommended.
Communications distance	Distance between nodes: 100 m max.
Process data	Fixed PDO mapping PDO mapping
Mailbox (CoE)	Emergency messages, SDO, SDO responses, and information
Distributed clock	FreeRun mode (asynchronous)
LED display	L/A IN (Link/Activity IN) × 1 L/A OUT (Link/Activity OUT) × 1 RUN × 1 ERR × 1
CiA402 drive profile	Velocity mode

EtherCAT Communication Unit Version Information

As a Sysmac Device, the MX2-series Multi-function Compact Inverter is designed to provide optimal functionality and enhanced operability when used in conjunction with a Machine Automation Control such as NJ/NX series and the automation software Sysmac Studio.

Unit Versions

Unit	Model	Unit version	
		Ver.1.0	Ver1.1
EtherCAT Communication Unit for MX2-Series	3G3AX-MX2-ECT	Supported	Supported
Compatible Sysmac Studio version (To connect the NJ Controller)		Version1.05 or higher*	Version1.05 or higher
Compatible Sysmac Studio version (To connect the NX Controller)		Version1.13 or higher*	Version1.13 or higher

* The function that was enhanced by the upgrade for Unit version1.1 can not be used. For detail, refer to "Function Support by Unit Version".

Function Support by Unit Version

Unit	Unit version	Unit version 1.0	Unit version 1.1
Model			
Item			
Store-function of back-up number of parameters		Not supported	Supported
Initializing function as parameters.		Not supported	Supported

Dimensions (Unit: mm)

3G3AX-MX2-ECT

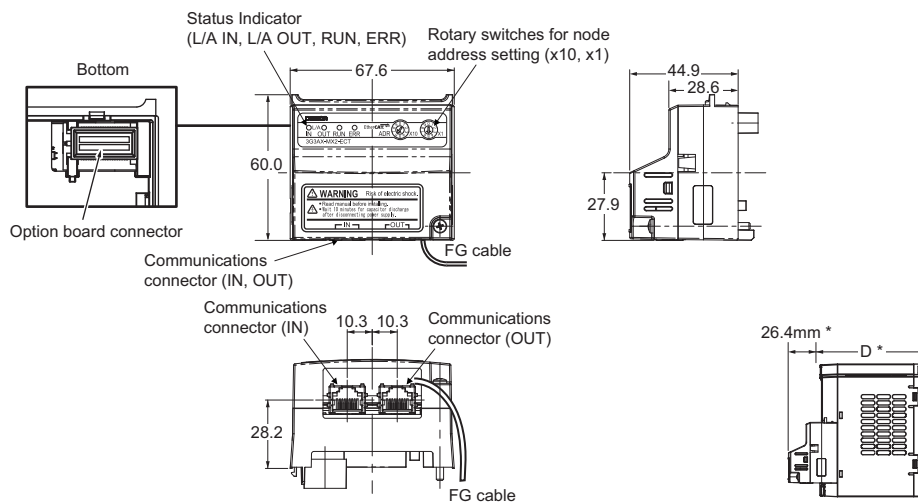

*After the EtherCAT Communication Unit is installed, dimension D of the inverter increases by 26.4 mm.
(Dimension D of the inverter varies depending on the capacity. Refer to the MX2-series V1 type USER'S MANUAL (Cat.No.I585))

MX2-Series CompoNet Communication Unit 3G3AX-MX2-CRT-E

This is the communication unit to connect the Multi-function Compact Inverter MX2 to CompoNet network.

Common Specification

Item		Specification
Power supply		Supplied from the inverter
Protective structure		IP20
Ambient operating temperature		- 10 to 50 °C
Ambient storage temperature		- 20 to 65 °C
Ambient operating humidity		20 to 90%RH (with no condensation)
Vibration resistance		5.9m/s ² (0.6G), 10 to 55Hz
Application environment		At a maximum altitude of 1,000 m; indoors (without corrosive gases or dust)
Insulation resistance		500VAC (between isolated circuits)
Weight		Approx. 170g
International standard	UL/cUL	UL508
	EC directive	EN61800-3: 2004 (2004/108/EC) Second environment, Category C3 EN61800-5-1: 2007 (2006/95/EC) SELV

CompoNet Communications Specifications

Item	Specification
Slave type	Word Slave Unit (Mixed)
Certification	CompoNet Conformance Tested
CompoNet Profile	AC Drive (0x02)
Node Address	0 to 63, set with inverter parameter P190 or the rotary switches.
Communication power supply	- (External power not required)
Baud rates supported	4 Mbps, 3 Mbps, 1.5 Mbps, 93.75 kbps. Automatically detecting baud rate of Master Unit
Default Connection path	Supported, set with inverter parameter P046
Supported Assemblies	Basic Remote IO (Output assembly 20, Input assembly 70) Extended Speed IO (21, 71) Extended Speed and Torque Control (123, 173) Special IO (100, 150) Extended Control IO (101, 151) Extended Control IO and Multi function IO monitor (101, 153) Flexible Format (139, 159) Extended Speed and Acceleration Control (110, 111)
EDS file	Depending on the MX2 inverter model

Dimensions (Unit: mm)

3G3AX-MX2-CRT-E

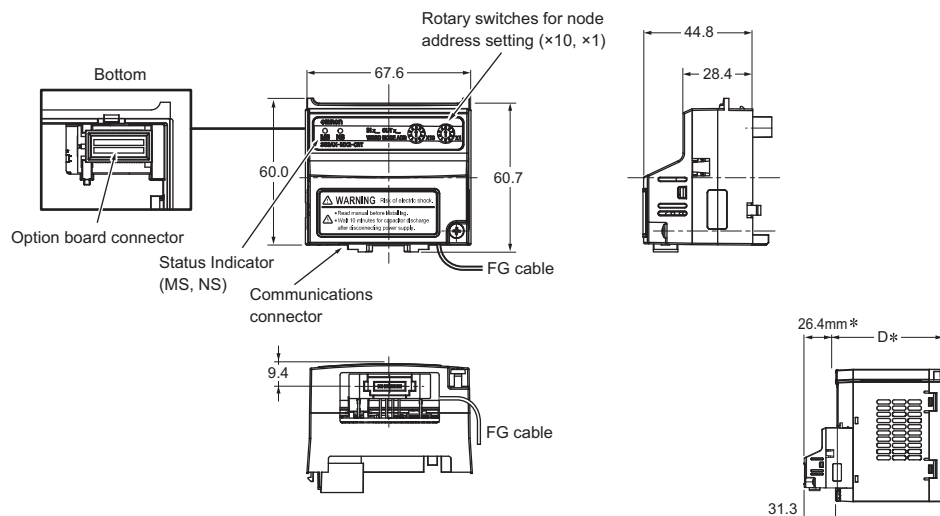

* After the CompoNet Communication Unit is installed, dimension D of the inverter increases by 26.4 mm. (Dimension D of the inverter varies depending on the capacity. Refer to the MX2-series V1 type USER'S MANUAL (Cat.No.I585))

Multi-function Compact Inverter MX2-Series V1 type

MX2-Series DeviceNet Communication Unit 3G3AX-MX2-DRT-E

This is the communication unit to connect the Multi-function Compact Inverter MX2 to DeviceNet network.

Common Specification

Item		Specification
Power supply		Supplied from the inverter
Protective structure		IP20
Ambient operating temperature		- 10 to 50 °C
Ambient storage temperature		- 20 to 65 °C
Ambient operating humidity		20 to 90%RH (with no condensation)
Vibration resistance		5.9m/s ² (0.6G), 10 to 55Hz
Application environment		At a maximum altitude of 1,000 m; indoors (without corrosive gases or dust)
Insulation resistance		500VAC (between isolated circuits)
Weight		Approx. 170g
International standard	UL/cUL	UL508
	EC directive	EN61800-3: 2004 (2004/108/EC) Second environment, Category C3
		EN61800-5-1: 2007 (2006/95/EC) SELV

DeviceNet Communications Specifications

Item	Specification
Certification	DeviceNet Conformance Tested
DeviceNet Profile	AC Drive (0x02)
Supported connections	Remote I/O: Master-Slave connection Poll Bit-Strobe COS Cyclic Explicit Messages Conform to DeviceNet specifications
Communication power supply	11 to 25VDC (MAX 50 mA, type 20 mA)
Unit device address range	MAC ID 0 to 63, set with inverter parameter P192
Baud rates supported	125, 250, or 500kbps. Automatically detects baud rate of Master Unit.
Default Connection path	Supported, set with inverter parameter P046
Supported Assemblies	Basic Remote IO (Output assembly 20, Input assembly 70) Extended Speed IO (21, 71) Extended Speed and Torque Control (123, 173) Special IO (100, 150) Extended Control IO (101, 151) Extended Control IO and Multi function IO monitor (101, 153) Flexible Format (139, 159) Extended Speed and Acceleration Control (110, 111) In case the DeviceNet master is configured using user allocation, only the input / output pairs can be configured.
EDS file	Depending on the MX2 Inverter model

Dimensions (Unit: mm)

3G3AX-MX2-DRT-E

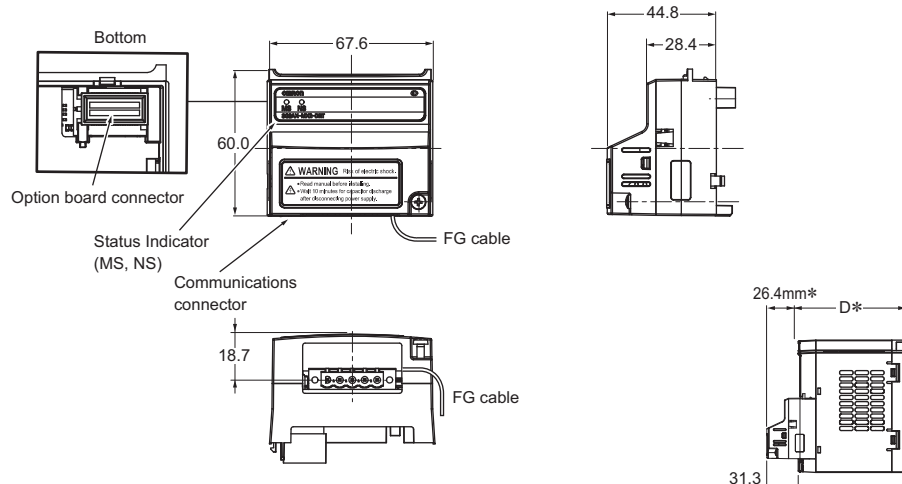

* After the DeviceNet Communication Unit is installed, dimension D of the inverter increases by 26.4 mm. (Dimension D of the inverter varies depending on the capacity. Refer to the MX2-series V1 type USER'S MANUAL (Cat.No.I585))

Options

Regenerative Braking Unit 3G3AX-RBU□□

Used with a Braking Resistor when the deceleration time of the motor is needed to be reduced in the MX2.

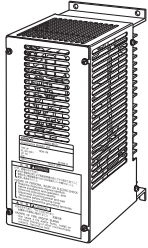

Connection Example

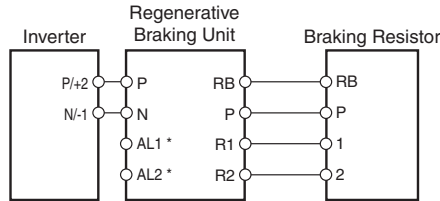

* The alarm output terminals for the Regenerative Braking Unit. Provide a circuit to turn off the primary power supply for the Inverter when the temperature relay of the built-in resistor or optional Braking Resistor is activated.

Specifications

Built-in Resistance Type (3G3AX-RBU21/-RBU22/-RBU41)

Class		3-phase 200-V class		3-phase 400-V class
Model name (3G3AX-)		RBU21	RBU22	RBU41*1
Connection resistance		17 Ω min.	17 Ω min.	34 Ω min.
Operating voltage ON/OFF		ON : 362.5 ± 5 V OFF: 355 ± 5 V (-5% or -10% setting available)		ON : 725 ± 5 V OFF: 710 ± 5 V (-5% or -10% setting available)
Operation indication		LED ON (Lit)		
Parallel interlocking operation function*2		5 units max.		
Built-in resistor	Internal resistance	120 W, 180 W	120 W, 20 W	120 W, 180 W × 2 in series
	Allowable consecutive ON time	10 s max.	0.5 s max.	10 s max.
	Allowable operation cycle	Cycle 1/10 (ON for 10 s, OFF for 90 s)	Cycle 1/80 (ON for 0.5 s, OFF for 40 s)	Cycle 1/10 (ON for 10 s, OFF for 90 s)
	Power consumption	Instantaneous 0.73 kW Short-time rating 120 W	Instantaneous 6.6 kW Short-time rating 120 W	Instantaneous 1.46 kW Short-time rating 240 W
Protective function	Built-in resistor overheat protection	<ul style="list-style-type: none"> Cooling fin temperature Relay operates at approximately 200°C or higher. Recovers at approximately 170°C or lower. Built-in temperature fuse (recovery impossible)*3 Rating of contact 250 V AC 200mA (R load) 12 V DC 500mA (R load) 42 V DC 200mA (R load) Minimum load 1mA (R load) 		
Operating environment	Ambient temperature	-10 to 50°C		
	Ambient storage temperature	-20 to 65°C		
	Ambient operating humidity	20% to 90% (with no condensation)		
	Vibration	5.9 m/s ² (0.6G) 10 to 55 Hz		
	Location	At a maximum altitude of 1,000 m (without corrosive gases or dust)		
Paint color		Munselle 5Y7/1 (cooling fan: aluminum ground color)		

*1 To use the braking resistor (Model: 3G3AX-RAB/RBB/RBC) for the 400-V class regenerative braking unit, be sure to remove the built-in resistor and connect two resistors of the same model in series. Using a 400-V class regenerative braking unit with only a single braking resistor connected may cause damage to the braking resistor.

*2 Use DIP switches to set the number of connected units.

*3 The built-in resistor has a thermal fuse. If the alarm terminals are not connected, the fuse may blow out in order to prevent the resistor from burning due to overheating. If the fuse blows out, the built-in resistor must be replaced.

Dimensions (Unit: mm)

3G3AX-RBU21/-RBU22/-RBU41

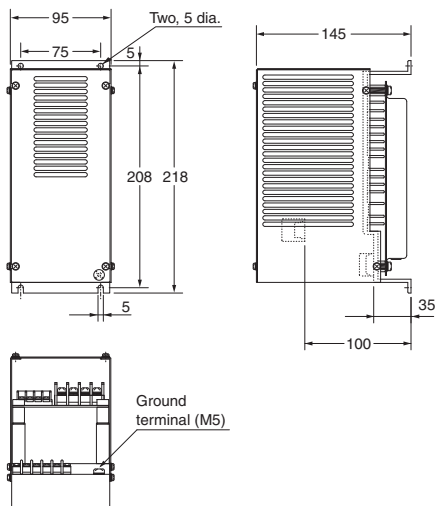

Multi-function Compact Inverter MX2-Series V1 type

Braking Resistor 3G3AX-RBA/-RBB/-RBC□□□□

Consumes the regenerative motor energy with a resistor to reduce deceleration time.

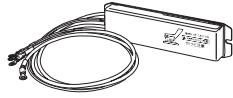
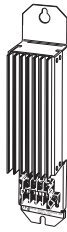
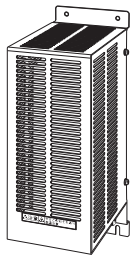

Connection Example

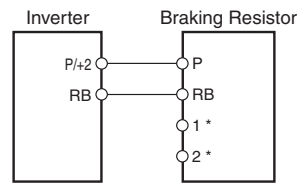

* The alarm output terminals for the Braking Resistor. Provide a circuit to turn off the primary power supply for the Inverter when the temperature relay of the Braking Resistor is activated.

Specifications

Model		Compact type (3G3AX-RBA□□□□)				Standard type (3G3AX-RBB□□□□)				Medium capacity type (3G3AX-RBC□□□□)		
		1201	1202	1203	1204	2001	2002	3001	4001	4001	6001	12001
Resistance	Capacity	120 W				200 W		300 W	400 W	400 W	600 W	1200 W
	Resistance (W)	180	100	50	35	180	100	50	35	50	35	17
Allowable braking frequency (%)		5	2.5	1.5	1.0	10	7.5	7.5	7.5	10		
Allowable continuous braking time (s)		20	12	5	3	30			20	10		
Weight (kg)		0.27				0.97	1.68	2.85	2.5	3.6	6.5	
Fault detection function		Built-in thermal (Contact capacity: 240 V AC 2 A max.) Minimum current: 5 mA, Normally ON (NC contact) Built-in temperature fuse (recovery impossible)*							Built-in temperature relay, Normally ON (NC contact) Contact capacity: 240 V AC 3 A (R load), 0.2 A (L load), 36 V DC 2 A (R load)			
General specifications	Ambient operating temperature	-10 to 50°C										
	Ambient storage temperature	-20 to 65°C										
	Ambient operating humidity	20% to 90% (RH) with no condensation										
	Vibration	5.9 m/s (0.6 G) 10 to 55 Hz Complies with JISC0911										
	Location	At a maximum altitude of 1,000 m (without corrosive gases or dust)										
Cooling method		Self-cooling										

* Built-in resistors are equipped with thermal fuses. If the alarm is not connected, the fuse may blow to prevent burnout due to overheating. If the fuse blows, the built-in resistor will need to be replaced.

Dimensions (Unit: mm)

3G3AX-RBA

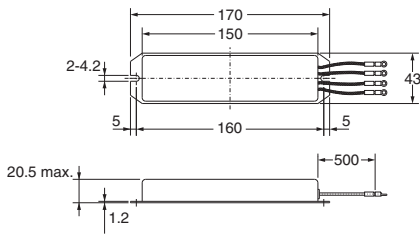

3G3AX-RBB

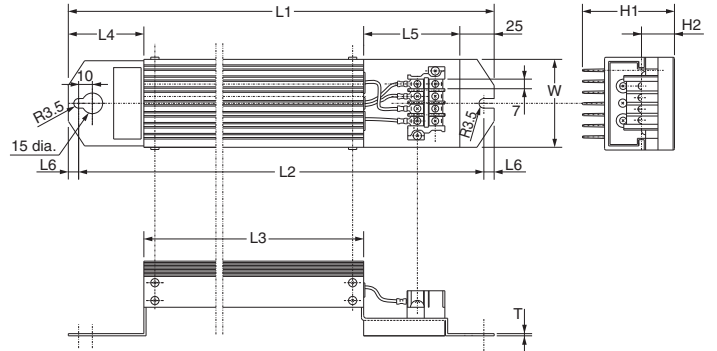

3G3AX-RBC4001

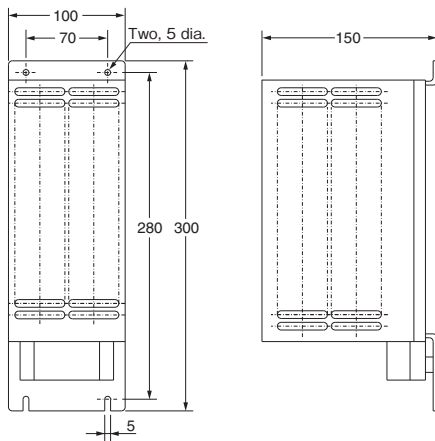

Model	Dimensions (mm)					
	L1	L2	L3	L4	L5	L6
3G3AX-RBB2001	310	295	160	55	70	7.5
3G3AX-RBB2002	310	295	160	55	70	7.5
3G3AX-RBB3001	470	455	320	55	70	7.5
3G3AX-RBB4001	435	422	300	50	60	6.5

Model	Dimensions (mm)				Weight (kg)	Screw size
	H1	H2	W	T		
3G3AX-RBB2001	67	12	64	1.6	0.97	M3.5
3G3AX-RBB2002	67	12	64	1.6	0.97	
3G3AX-RBB3001	67	12	64	1.6	1.68	
3G3AX-RBB4001	94	15	76	2	2.85	

3G3AX-RBC6001

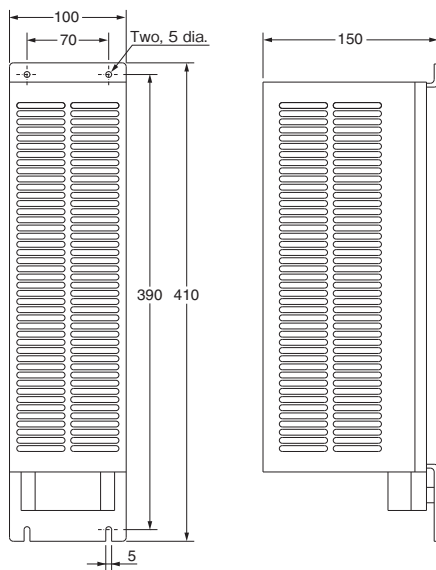

3G3AX-RBC12001

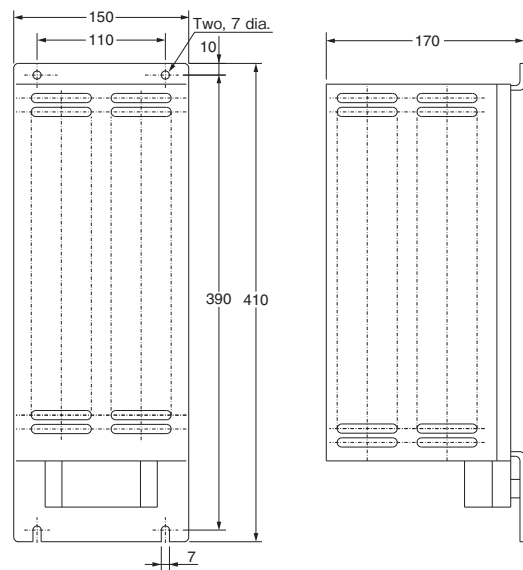

Multi-function Compact Inverter MX2-Series V1 type

Radio Noise Filter 3G3AX-ZCL□

Connected to the inverter input/output cables to reduce noise coming into the inverter from the power supply line and noise flowing from the inverter into the power supply line.

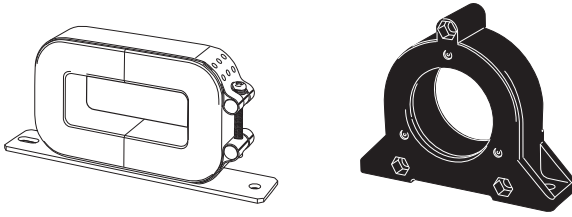

Connection Example

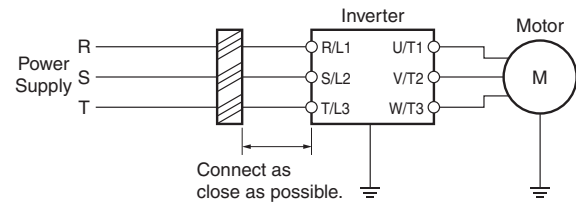

- Note 1: Wind each of three phase wires in the same direction.
- 2: Can be used on both the input and output sides of the Inverter.

Specifications

3G3AX-ZCL1

Applicable Inverter capacity (kW)	200 V class				400 V class			
	Input		output		Input		output	
	Quan- tity	No. of turns	Quan- tity	No. of turns	Quan- tity	No. of turns	Quan- tity	No. of turns
0.4	-	-	-	-	1	4	1	4
0.75					1	4	1	4
1.5					1	4	1	4
2.2					1	4	1	4
3.0					1	4	1	4
3.7	1	4	1	4	-	-	-	-
4.0	-	-	-	-	1	4	1	4
5.5	1	4	1	4	1	4	1	4
7.5	1	4	1	4	1	4	1	4
11	1	4	1	4	1	4	1	4
15	1	4	1	4	1	4	1	4

Specifications

3G3AX-ZCL2

Applicable Inverter capacity (kW)	200 V class				400 V class			
	Input		output		Input		output	
	Quantity	No. of turns	Quantity	No. of turns	Quantity	No. of turns	Quantity	No. of turns
0.1	1	4	1	4	-		-	
0.2	1	4	1	4	-		-	
0.4	1	4	1	4	1	4	1	4
0.75	1	4	1	4	1	4	1	4
1.5	1	4	1	4	1	4	1	4

Applicable Inverter capacity (kW)	200 V class				400 V class			
	Input		output		Input		output	
	Quantity	No. of turns	Quantity	No. of turns	Quantity	No. of turns	Quantity	No. of turns
2.2	1	4	1	4	1	4	1	4
3.0	-		-		1	4	1	4
4.0	-		-		1	4	1	4
5.5	-		-		1	4	1	4

Note: Select options by the maximum applicable motor capacity of heavy and light load rating.

Dimensions (Unit: mm)

3G3AX-ZCL1

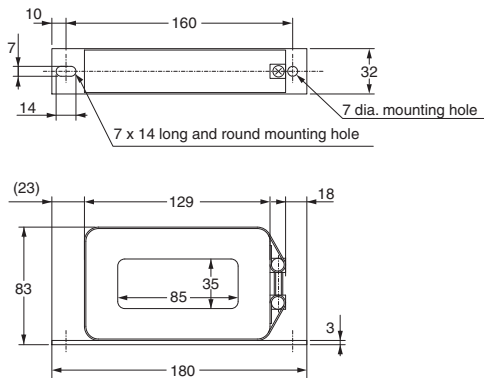

3G3AZ-ZCL2

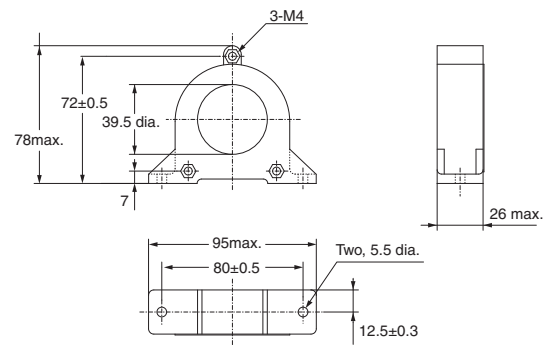

Multi-function Compact Inverter MX2-Series V1 type

Input Noise Filter 3G3AX-NFI□□

Reduces noise coming into the inverter from the power supply line and noise flowing from the inverter into the power supply line. Connect as close to the Inverter as possible.

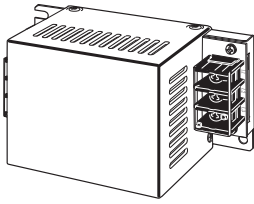

Connection Example

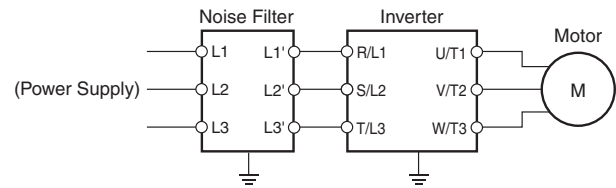

Specifications

Power supply	Model	Inverter model	Rated input current In (A) at an ambient temperature of 50°C	Power loss (W)	Leakage current (mA/phase) at 60 Hz
3-phase 200 VAC	3G3AX-NFI21	3G3MX2-A2001-V1	3 × 6 A	3	< 1.5 (250 V)
	3G3AX-NFI21	3G3MX2-A2002-V1	3 × 6 A	3	< 1.5 (250 V)
	3G3AX-NFI21	3G3MX2-A2004-V1	3 × 6 A	3	< 1.5 (250 V)
	3G3AX-NFI22	3G3MX2-A2007-V1	3 × 10 A	4	< 1.5 (250 V)
	3G3AX-NFI23	3G3MX2-A2015-V1	3 × 20 A	6	< 1.5 (250 V)
	3G3AX-NFI23	3G3MX2-A2022-V1	3 × 20 A	6	< 1.5 (250 V)
	3G3AX-NFI24	3G3MX2-A2037-V1	3 × 30 A	9	< 1.5 (250 V)
	3G3AX-NFI25	3G3MX2-A2055-V1	3 × 40 A	12	< 1.5 (250 V)
	3G3AX-NFI26	3G3MX2-A2075-V1	3 × 60 A	17	< 1.5 (250 V)
	3G3AX-NFI27	3G3MX2-A2110-V1	3 × 80 A	21	< 1.5 (250 V)
3G3AX-NFI28	3G3MX2-A2150-V1	3 × 100 A	23	< 1.5 (250 V)	
1-phase 200 VAC	3G3AX-NFI21	3G3MX2-AB001-V1	3 × 6 A	3	< 1.5 (250 V)
	3G3AX-NFI21	3G3MX2-AB002-V1	3 × 6 A	3	< 1.5 (250 V)
	3G3AX-NFI22	3G3MX2-AB004-V1	3 × 10 A	4	< 1.5 (250 V)
	3G3AX-NFI23	3G3MX2-AB007-V1	3 × 20 A	6	< 1.5 (250 V)
	3G3AX-NFI24 3G3AX-NFI23*	3G3MX2-AB015-V1	3 × 30 A 3 × 20 A	9 6	< 1.5 (250 V)
	3G3AX-NFI24	3G3MX2-AB022-V1	3 × 30 A	9	< 1.5 (250 V)
3-phase 400 VAC	3G3AX-NFI41	3G3MX2-A4004-V1	3 × 7 A	2	< 7.5 (480 V)
	3G3AX-NFI41	3G3MX2-A4007-V1	3 × 7 A	2	< 7.5 (480 V)
	3G3AX-NFI41	3G3MX2-A4015-V1	3 × 7 A	2	< 7.5 (480 V)
	3G3AX-NFI42	3G3MX2-A4022-V1	3 × 10 A	4	< 7.5 (480 V)
	3G3AX-NFI42	3G3MX2-A4030-V1	3 × 10 A	4	< 7.5 (480 V)
	3G3AX-NFI43	3G3MX2-A4040-V1	3 × 20 A	6	< 7.5 (480 V)
	3G3AX-NFI43	3G3MX2-A4055-V1	3 × 20 A	6	< 7.5 (480 V)
	3G3AX-NFI44	3G3MX2-A4075-V1	3 × 30 A	9	< 7.5 (480 V)
	3G3AX-NFI45	3G3MX2-A4110-V1	3 × 40 A	12	< 7.5 (480 V)
	3G3AX-NFI46	3G3MX2-A4150-V1	3 × 50 A	15	< 7.5 (480 V)

* With the 3G3AX-NFI23, only the CT rating is supported.

Model	Case enclosure rating	Terminal size	Wire dia.	Weight (kg)
3G3AX-NFI21	Plastic, IP00	M4	1.25 mm ²	0.5
3G3AX-NFI22	Plastic, IP00	M4	2 mm ²	0.6
3G3AX-NFI23	Plastic, IP00	M4	2 mm ² , 3.5 mm ²	0.7
3G3AX-NFI24	Plastic, IP00	M4	5.5 mm ²	0.8
3G3AX-NFI25	Plastic, IP00	M5	8 mm ²	1.4
3G3AX-NFI26	Plastic, IP00	M5	14 mm ²	1.8
3G3AX-NFI27	Metal, IP00	M6	22 mm ²	3.6
3G3AX-NFI28	Metal, IP00	M8	30 mm ²	4.6
3G3AX-NFI41	Plastic, IP00	M4	1.25 mm ² , 2 mm ²	0.7
3G3AX-NFI42	Plastic, IP00	M4	2 mm ²	0.7
3G3AX-NFI43	Plastic, IP00	M4	2 mm ² , 3.5 mm ²	0.7
3G3AX-NFI44	Plastic, IP00	M4	5.5 mm ²	0.8
3G3AX-NFI45	Plastic, IP00	M5	8 mm ²	1.4
3G3AX-NFI46	Plastic, IP00	M5	14 mm ²	1.6

Note: Select options by the maximum applicable motor capacity of heavy and light load rating.

Multi-function Compact Inverter MX2-Series V1 type

Dimensions (Unit: mm)

3G3AX-NFI21
3G3AX-NFI22

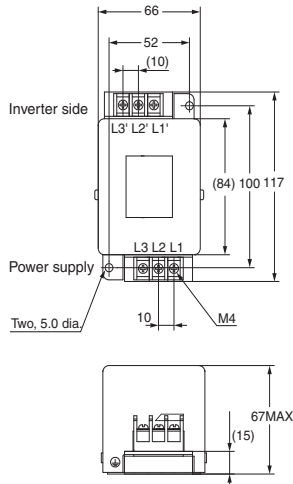

3G3AX-NFI25/3G3AX-NFI26
3G3AX-NFI45/3G3AX-NFI46

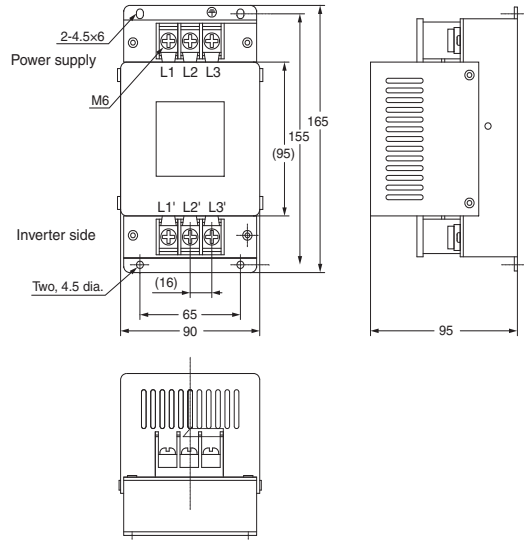

3G3AX-NFI23/3G3AX-NFI24
3G3AX-NFI41/3G3AX-NFI42
3G3AX-NFI43/3G3AX-NFI44

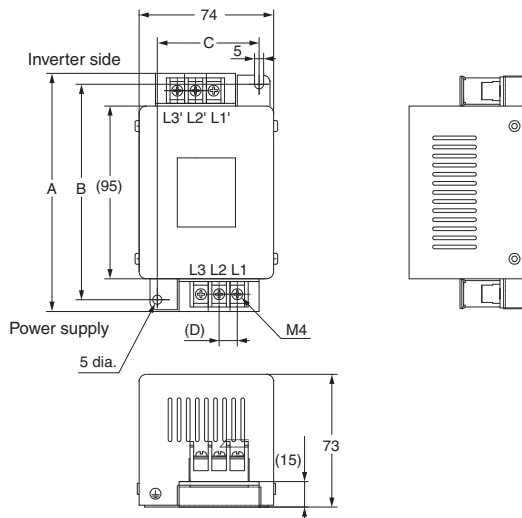

Model	Dimensions (mm)			
	A	B	C	D
3G3AX-NFI23	128	118	56	10
3G3AX-NFI24	144	130	56	11
3G3AX-NFI41	144	130	56	11
3G3AX-NFI42	144	130	56	11
3G3AX-NFI43	144	130	56	11
3G3AX-NFI44	144	130	56	11

3G3AX-NFI27/3G3AX-NFI28

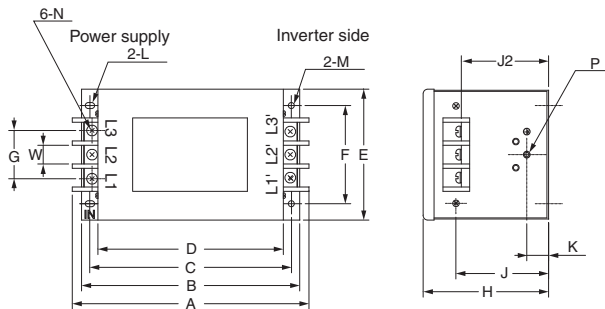

Model	Dimensions (mm)															
	A	B	C	D	E	F	G	H	J	J2	K	L	M	N	P	W
3G3AX-NFI27	217	200	185	170	120	90	44	115	85	82	20	R2.75 Length 7	5.5 dia.	M6	M4	17
3G3AX-NFI28	254	230	215	200	150	120	57	115	80	75	30	R3.75 Length 8	6.5 dia.	M8	M6	23

Multi-function Compact Inverter MX2-Series V1 type

Output Noise Filter 3G3AX-NFO□□

Reduces noise generated by the Inverter. Connect as close to the Inverter as possible.

Connection Example

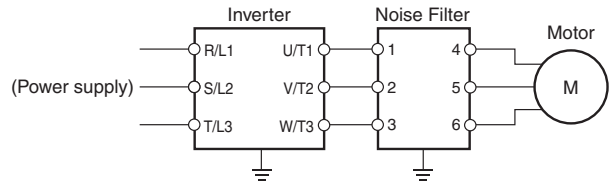
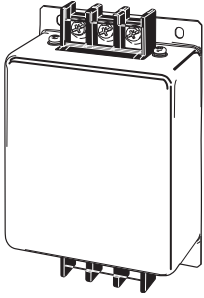

Specifications

Power supply	Model	Rated current (A)	Inverter model			Weight (kg)
			3-phase AC 200 V class	1-phase AC 200 V class	3-phase AC 400 V class	
3-phase, 3-wire Rated voltage 500 VAC	3G3AX-NFO01	6	3G3MX2-A2001-V1 /-A2002-V1/-A2004-V1	3G3MX2-AB001-V1 /-AB002-V1	3G3MX2-A4004-V1 /-A4007-V1	0.7
	3G3AX-NFO02	12	3G3MX2-A2007-V1 /-A2015-V1	3G3MX2-AB004-V1 /-AB007-V1	3G3MX2-A4015-V1 /-A4022-V1/-A4030-V1	0.9
	3G3AX-NFO03	25	3G3MX2-A2022-V1 /-A2037-V1	3G3MX2-AB015-V1 /-AB022-V1	3G3MX2-A4040-V1 /-A4055-V1/-A4075-V1	2.1
	3G3AX-NFO04	50	3G3MX2-A2055-V1 /-A2075-V1	-	3G3MX2-A4110-V1 /-A4150-V1	3.7
	3G3AX-NFO05	75	3G3MX2-A2110-V1	-	-	5.7
	3G3AX-NFO06	100	3G3MX2-A2150-V1	-	-	8.4

Note: Select options by the maximum applicable motor capacity of heavy and light load rating.

Dimensions (Unit: mm)

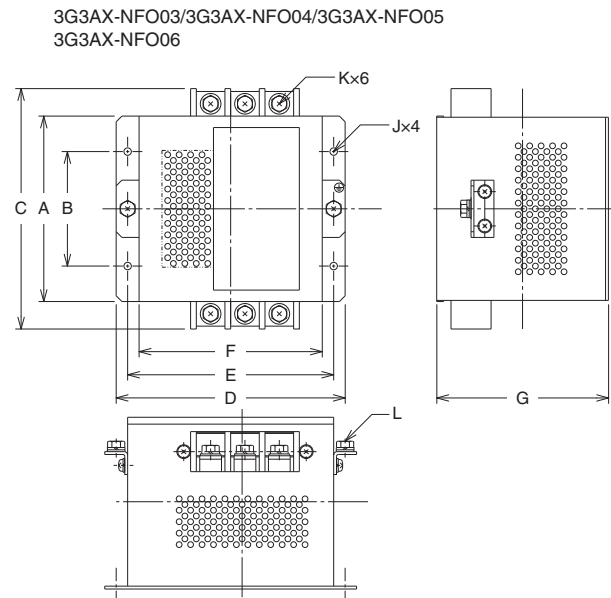
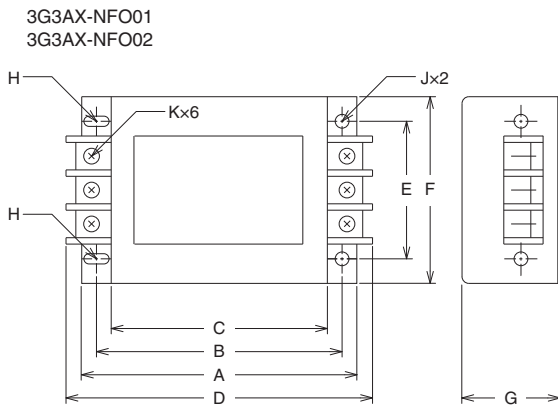

Model	A	B	C	D	E	F	G	H	J	K	L
3G3AX-NFO01	140	125	110	156	70	95	50	R: 2.25mm Length: 6mm	4.5 mm dia.	M4	-
3G3AX-NFO02	160	145	130	176	80	110	70	R: 2.75mm Length: 7mm	5.5 mm dia.	M4	-
3G3AX-NFO03	112	80	154	160	145	130	120	-	6.5 mm dia.	M4	-
3G3AX-NFO04	162	100	210	200	180	160	150	-	6.5 mm dia.	M5	M5
3G3AX-NFO05	182	100	230	220	200	180	170	-	6.5 mm dia.	M6	M6
3G3AX-NFO06	182	100	237	220	200	180	170	-	6.5 mm dia.	M8	M8

DC Reactor 3G3AX-DL□□□□

Used to suppress harmonic current generated from the Inverter.

Suppresses harmonic current better than the AC Reactor and can be used with the AC Reactor.

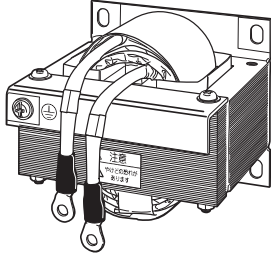

Connection Example

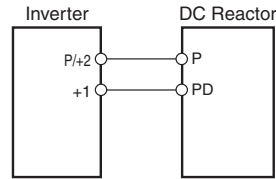

Specifications

Inverter Input power supply	Model	Figure No.	Applicable Inverter	Dimensions (mm) Bmax: coil dimensions									Weight (kg)	Standard applicable wire
				W	D	H	A	B	X	Y	C	K		
3/1-phase 200 VAC	3G3AX-DL2002	Fig. 1	3G3MX2-A2001-V1, AB001-V1	66	90	98	-	85	56	72	5.2 × 8	M4	0.8	1.25 mm ² min.
	3G3AX-DL2004		3G3MX2-A2002-V1, AB002-V1	66	90	98	-	95	56	72	5.2 × 8	M4	1.0	1.25 mm ² min.
	3G3AX-DL2007		3G3MX2-A2004-V1, AB004-V1	66	90	98	-	105	56	72	5.2 × 8	M4	1.3	2 mm ² min.
	3G3AX-DL2015		3G3MX2-A2007-V1, AB007-V1	66	90	98	-	115	56	72	5.2 × 8	M4	1.6	2 mm ² min.
	3G3AX-DL2022		3G3MX2-A2015-V1, AB015-V1	86	100	116	-	105	71	80	6 × 9	M4	2.1	2 mm ² min.
	3G3AX-DL2037	3G3MX2-A2022-V1, AB022-V1	86	100	118	-	120	71	80	6 × 9	M4	2.6	3.5 mm ² min.	
	3G3AX-DL2055	Fig. 2	3G3MX2-A2037-V1	111	100	210	-	110	95	80	7 × 11	M5	3.6	8 mm ² min.
	3G3AX-DL2075		3G3MX2-A2055-V1	111	100	212	-	120	95	80	7 × 11	M6	3.9	14 mm ² min.
	3G3AX-DL2110		3G3MX2-A2075-V1	146	120	252	-	110	124	96	7 × 11	M6	6.5	22 mm ² min.
	3G3AX-DL2150		3G3MX2-A2110-V1	146	120	256	-	120	124	96	7 × 11	M8	7.0	38 mm ² min.
3G3AX-DL2220	Fig. 3	3G3MX2-A2150-V1	120	175	356	140	145	98	151	7 × 11	M8	9.0	60 mm ² min.	

Multi-function Compact Inverter MX2-Series V1 type

Inverter Input power supply	Model	Figure No.	Applicable Inverter	Dimensions (mm) Bmax: coil dimensions									Weight (kg)	Standard applicable wire
				W	D	H	A	B	X	Y	C	K		
3-phase 400 VAC	3G3AX-DL4007	Fig. 1	3G3MX2-A4004-V1	66	90	98	-	95	56	72	5.2 × 8	M4	1.1	1.25 mm ² min.
	3G3AX-DL4015		3G3MX2-A4007-V1*	66	90	98	-	115	56	72	5.2 × 8	M4	1.6	2 mm ² min.
	3G3AX-DL4022		3G3MX2-A4007-V1, A4015-V1	86	100	116	-	105	71	80	6 × 9	M4	2.1	2 mm ² min.
	3G3AX-DL4037		3G3MX2-A4022-V1 A4030-V1	86	100	116	-	120	71	80	6 × 9	M4	2.6	2 mm ² min.
	3G3AX-DL4055		3G3MX2-A4040-V1	111	100	138	-	110	95	80	7 × 11	M4	3.6	3.5 mm ² min.
	3G3AX-DL4075		3G3MX2-A4055-V1*	111	100	138	-	115	95	80	7 × 11	M4	3.9	3.5 mm ² min.
	3G3AX-DL4110	Fig. 2	3G3MX2-A4055-V1, A4075-V1*	146	120	250	-	105	124	96	7 × 11	M5	5.2	5.5 mm ² min.
	3G3AX-DL4150		3G3MX2-A4075-V1, A4110-V1	146	120	252	-	120	124	96	7 × 11	M6	7.0	14 mm ² min.
	3G3AX-DL4220	Fig. 3	3G3MX2-A4150-V1	120	175	352	140	145	98	151	7 × 11	M6	9.5	22 mm ² min.

Note: Select options by the maximum applicable motor capacity of heavy and light load rating.

* Only the CT rating is supported.

Dimensions (Unit: mm)

Fig. 1

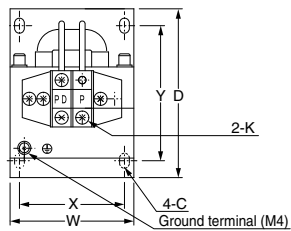

Fig. 2

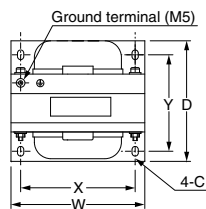
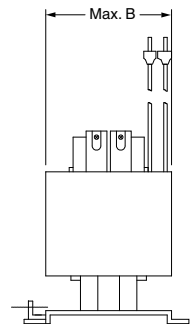
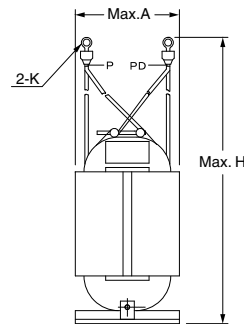
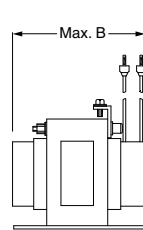
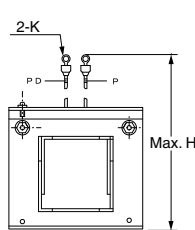
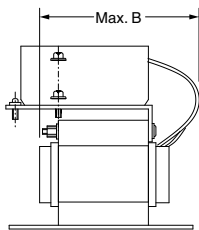
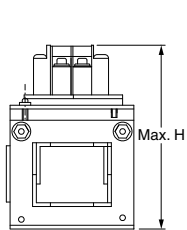
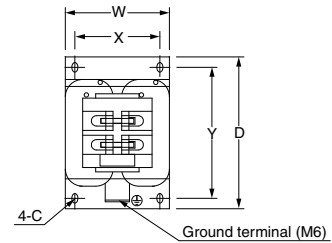
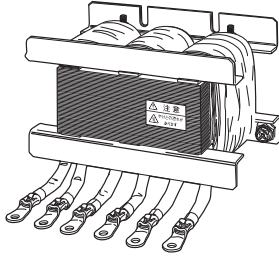

Fig. 3



AC Reactor 3G3AX-AL□□□□

Connect the AC Reactor if the capacity of the power supply is much larger than that of the Inverter or the power factor is required to be improved.



Connection Example

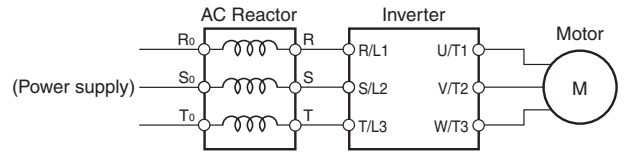

Specifications

Model	Inverter model	Motor capacity		Dimensions (mm)										Weight (kg)
		VT	CT	A	C	D	E	H	H1	J	W	X	Y	
3G3AX-AL2025	3G3MX2-A2001-V1	√	√	120	82	60	40	150	94	-	-	50	67	2.8
	3G3MX2-A2002-V1	√	√											
	3G3MX2-A2004-V1	√	√											
	3G3MX2-A2007-V1	√	√											
	3G3MX2-AB001-V1	√	√											
	3G3MX2-AB002-V1	√	√											
3G3AX-AL2055	3G3MX2-A2015-V1	√	√	120	98	60	40	150	94	-	-	50	75	4.0
	3G3MX2-A2022-V1	√	√											
	3G3MX2-AB007-V1	√	√											
	3G3MX2-AB015-V1*	-	√											
3G3AX-AL2110	3G3MX2-A2037-V1	√	√	150	103	70	55	170	108	5.3	12.0	60	80	5.0
	3G3MX2-A2055-V1*	-	√											
	3G3MX2-AB015-V1	√	√											
	3G3MX2-AB022-V1	√	√											
3G3AX-AL2220	3G3MX2-A2055-V1	√	√	180	113	75	55	190	140	8.4	16.5	90	90	10.0
	3G3MX2-A2075-V1	√	√											
	3G3MX2-A2110-V1*	-	√											
3G3AX-AL2330	3G3MX2-A2110-V1	√	√	180	113	85	60	230	140	8.4	22.0	125	90	11.0
	3G3MX2-A2150-V1	√	√											
3G3AX-AL4025	3G3MX2-A4004-V1	√	√	130	82	60	40	150	94	-	-	50	67	2.7
	3G3MX2-A4007-V1	√	√											
3G3AX-AL4055	3G3MX2-A4015-V1	√	√	130	98	60	40	150	94	-	-	50	75	4.0
	3G3MX2-A4022-V1	√	√											
	3G3MX2-A4030-V1	√	√											
3G3AX-AL4110	3G3MX2-A4040-V1	√	√	150	116	75	55	170	106	-	-	60	98	6.0
	3G3MX2-A4055-V1*	-	√											
3G3AX-AL4220	3G3MX2-A4055-V1	√	√	180	103	75	55	190	140	5.3	12.0	100	80	10.0
	3G3MX2-A4075-V1	√	√											
	3G3MX2-A4110-V1*	-	√											
3G3AX-AL4330	3G3MX2-A4110-V1	√	√	180	123	85	60	230	140	6	16.5	100	100	11.5
	3G3MX2-A4150-V1	√	√											

Note: Select options by the maximum applicable motor capacity of heavy and light load rating.

* Only the CT rating is supported.

Multi-function Compact Inverter MX2-Series V1 type

Dimensions (Unit: mm)

3G3AX-AL2025
3G3AX-AL2055

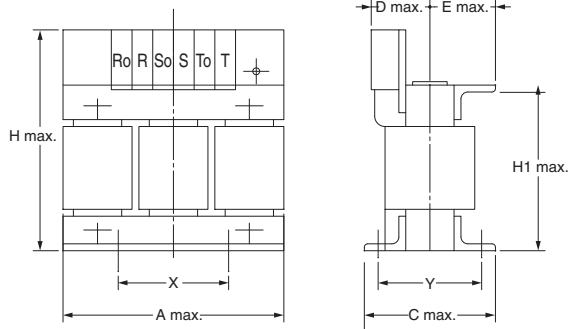

3G3AX-AL2110/3G3AX-AL2220
3G3AX-AL2330

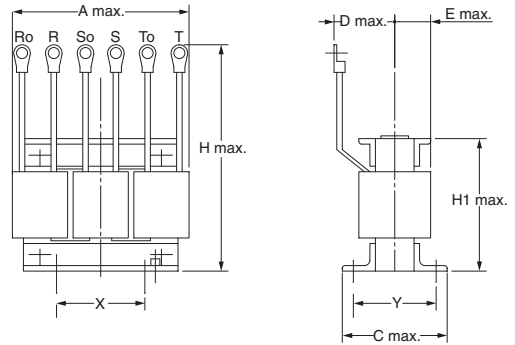

3G3AX-AL4025/3G3AX-AL4055
3G3AX-AL4110

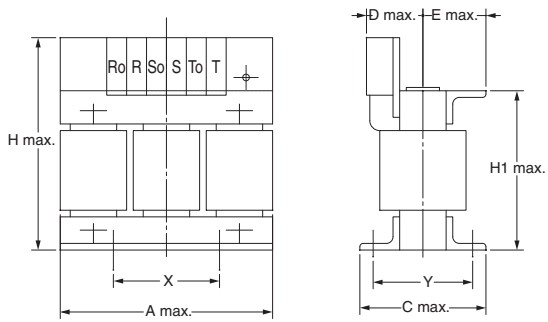

3G3AX-AL4220/3G3AX-AL4330

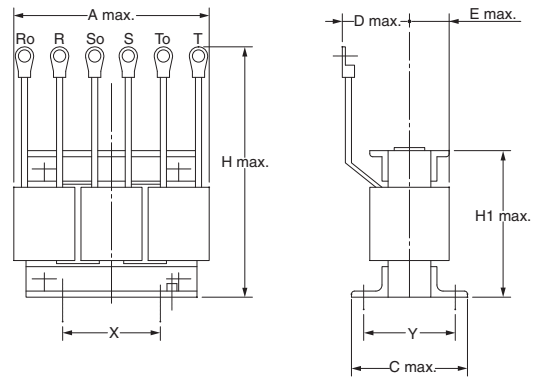

Digital Operator

Used to set parameters, perform various monitoring, and start and stop the Inverter.

3G3AX-OP01



Dimensions

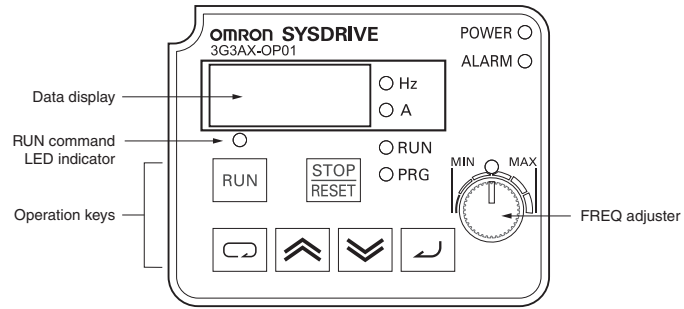

Dimensions	Height (55 mm) × Width (70 mm) × Depth (10 mm)
-------------------	--

Digital operator extension cable 3G3AX-OPCN□

Used to install the Digital Operator away from the Inverter.

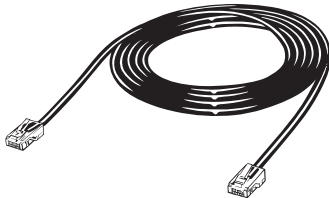

3G3AX-OPCN1 (Cable length: 1 m)
3G3AX-OPCN3 (Cable length: 3 m)

Ordering Information

■ System Configuration.....	33
■ Interpreting Model Numbers	34
■ Ordering Information	34
3G3MX2 Inverter Models	34
Communication Unit.....	34
Related Options	35
Recommended EtherCAT Communications Cables	40
Software	41
■ Overview of Inverter Selection	42
■ Related Manuals.....	46
■ Other Products in the Inverter Series	46

Sysmac is a trademark or registered trademark of OMRON Corporation in Japan and other countries for OMRON factory automation products.

Windows is registered trademarks of Microsoft Corporation in the USA and other countries.

EtherCAT® is registered trademark and patented technology, licensed by Beckhoff Automation GmbH, Germany.

CompoNet™ and DeviceNet™ are the trademarks of ODVA.

Other company names and product names in this document are the trademarks or registered trademarks of their respective companies.

The product photographs and figures that are used in this catalog may vary somewhat from the actual products.

Microsoft product screen shot(s) reprinted with permission from Microsoft Corporation.

System Configuration

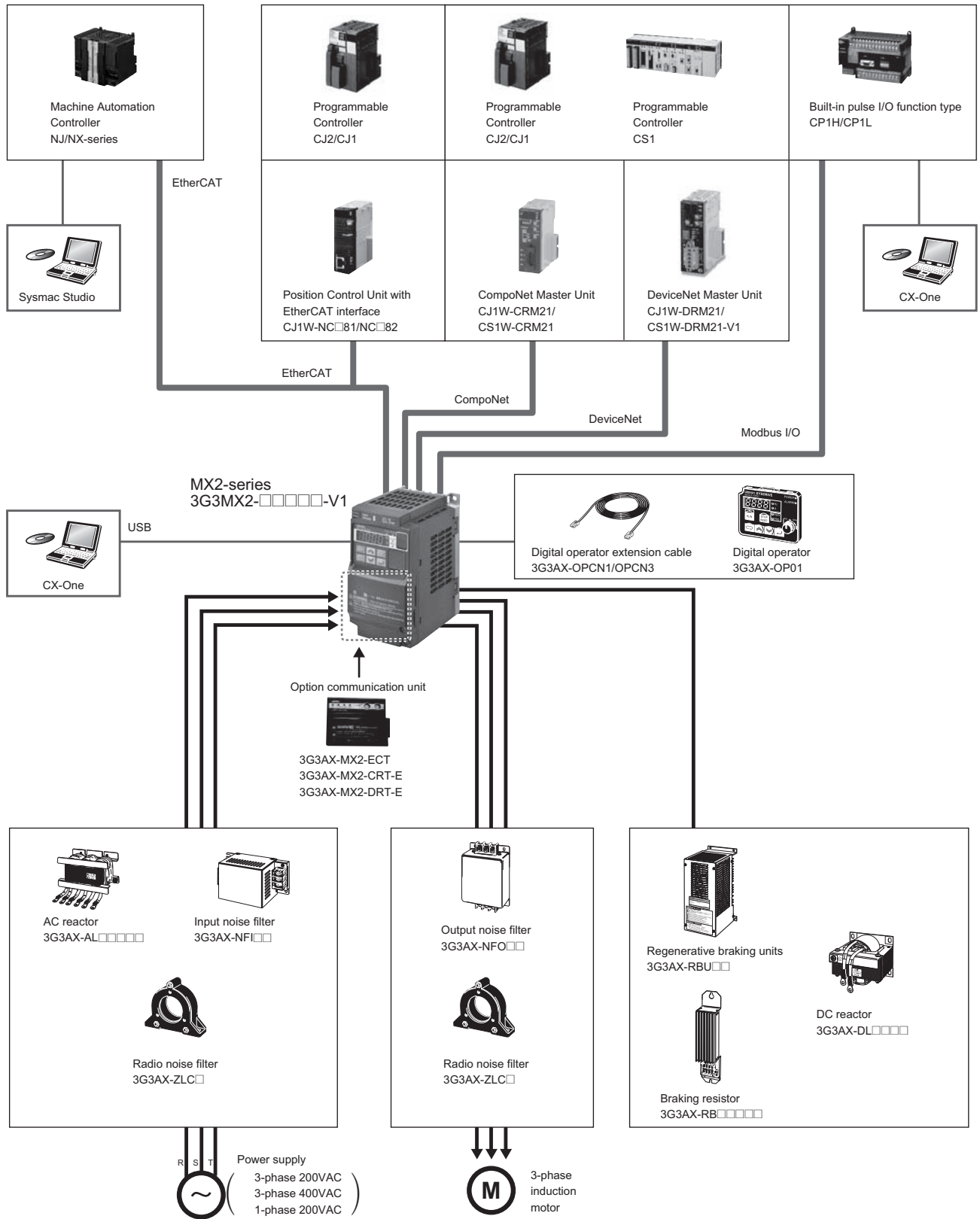

Interpreting Model Numbers

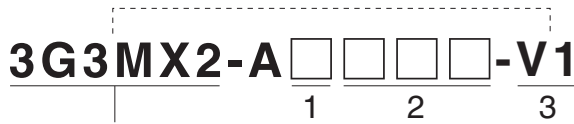

MX2 Series V1 type

1) Voltage class

B	1-phase 200 VAC (200-V class)
2	3-phase 200 VAC (200-V class)
4	3-phase 400 VAC (400-V class)

2) Max. applicable motor capacity (CT)

001	0.1 kW
002	0.2 kW
004	0.4 kW
007	0.75 kW
015	1.5 kW
022	2.2 kW
030	3.0 kW
037	3.7 kW
040	4.0 kW
055	5.5 kW
075	7.5 kW
110	11 kW
150	15 kW

3) Area

-V	Japan and areas other than China and Europe
-ZV1	China
-E	Europe

Ordering Information

3G3MX2 Inverter Models

Note: Inverters with model numbers ending in "-V1" are designed to be used in areas other than China and Europe. Refer to the above "Interpreting Model Numbers" for the model numbers for China and Europe.

Rated voltage	Enclosure ratings	Max. applicable motor capacity		Model
		CT: Heavy load	VT: Light load	
3-phase 200 VAC	IP20	0.1kW	0.2 kW	3G3MX2-A2001-V1
		0.2 kW	0.4 kW	3G3MX2-A2002-V1
		0.4 kW	0.75 kW	3G3MX2-A2004-V1
		0.75 kW	1.1 kW	3G3MX2-A2007-V1
		1.5 kW	2.2 kW	3G3MX2-A2015-V1
		2.2 kW	3.0 kW	3G3MX2-A2022-V1
		3.7 kW	5.5 kW	3G3MX2-A2037-V1
		5.5 kW	7.5 kW	3G3MX2-A2055-V1
		7.5 kW	11 kW	3G3MX2-A2075-V1
		11 kW	15 kW	3G3MX2-A2110-V1
3-phase 400 VAC	IP20	15 kW	18.5 kW	3G3MX2-A2150-V1
		0.4 kW	0.75 kW	3G3MX2-A4004-V1
		0.75 kW	1.5 kW	3G3MX2-A4007-V1
		1.5 kW	2.2 kW	3G3MX2-A4015-V1
		2.2 kW	3.0 kW	3G3MX2-A4022-V1
		3.0 kW	4.0 kW	3G3MX2-A4030-V1
		4.0 kW	5.5 kW	3G3MX2-A4040-V1
		5.5 kW	7.5 kW	3G3MX2-A4055-V1
		7.5 kW	11 kW	3G3MX2-A4075-V1
		11 kW	15 kW	3G3MX2-A4110-V1
1-phase 200 VAC	IP20	15 kW	18.5 kW	3G3MX2-A4150-V1
		0.1 kW	0.2 kW	3G3MX2-AB001-V1
		0.2 kW	0.4 kW	3G3MX2-AB002-V1
		0.4 kW	0.55 kW	3G3MX2-AB004-V1
		0.75 kW	1.1 kW	3G3MX2-AB007-V1
		1.5 kW	2.2 kW	3G3MX2-AB015-V1
		2.2 kW	3.0 kW	3G3MX2-AB022-V1

Communication Unit

Name	Model
EtherCAT Communication Unit	3G3AX-MX2-ECT
CompoNet Communication Unit	3G3AX-MX2-CRT-E
DeviceNet Communication Unit	3G3AX-MX2-DRT-E

Related Options

Name	Specifications		Model
Regenerative Braking Units	3-phase 200 VAC	General purpose with Braking resistor	3G3AX-RBU21
		High Regeneration purpose with Braking resistor	3G3AX-RBU22
	3-phase 400 VAC	General purpose with Braking resistor	3G3AX-RBU41
Braking Resistor	Compact type	Resistor 120 W, 180 Ω	3G3AX-RBA1201
		Resistor 120 W, 100 Ω	3G3AX-RBA1202
		Resistor 120 W, 5 Ω	3G3AX-RBA1203
		Resistor 120 W, 35 Ω	3G3AX-RBA1204
	Standard type	Resistor 200 W, 180 Ω	3G3AX-RBB2001
		Resistor 200 W, 100 Ω	3G3AX-RBB2002
		Resistor 300 W, 50 Ω	3G3AX-RBB3001
		Resistor 400 W, 35 Ω	3G3AX-RBB4001
	Medium capacity type	Resistor 400 W, 50 Ω	3G3AX-RBC4001
		Resistor 600 W, 35 Ω	3G3AX-RBC6001
	Resistor 1200 W, 17 Ω	3G3AX-RBC12001	

Regenerative Braking Unit and Braking Resistor Combination

Inverter			Usage conditions		Regenerative braking unit		Braking resistor		Connection configuration	Restrictions	
Voltage	Max.applicable motor capacity (kW)	Model	%ED *1 [%]	Approximate braking torque [% *2]	Model	Number of units	Model	Number of units		Allowable continuous braking time(s)	Min. connectable resistance [Ω]
200-V Class	0.1	3G3MX2-A2001-V1 3G3MX2-AB001-V1	3.0%	220%	Built-in Inverter		3G3AX-RBA1201	1	1	20	100
			10.0%	220%			3G3AX-RBB2001	1	1	30	100
	0.2	3G3MX2-A2002-V1 3G3MX2-AB002-V1	3.0%	220%	Built-in Inverter		3G3AX-RBA1201	1	1	20	100
			10.0%	220%			3G3AX-RBB2001	1	1	30	100
	0.4	3G3MX2-A2004-V1 3G3MX2-AB004-V1	3.0%	220%	Built-in Inverter		3G3AX-RBA1201	1	1	20	100
			10.0%	220%			3G3AX-RBB2001	1	1	30	100
	0.75	3G3MX2-A2007-V1 3G3MX2-AB007-V1	3.0%	120%	Built-in Inverter		3G3AX-RBA1201	1	1	20	50
			10.0%	120%			3G3AX-RBB2001	1	1	30	50
	1.5	3G3MX2-A2015-V1 3G3MX2-AB015-V1	2.5%	110%	Built-in Inverter		3G3AX-RBA1202	1	1	12	50
			10.0%	215%			3G3AX-RBC4001	1	1	10	50
	2.2	3G3MX2-A2022-V1 3G3MX2-AB022-V1	3.0%	150%	Built-in Inverter		3G3AX-RBB3001	1	1	30	35
			10.0%	150%			3G3AX-RBC4001	1	1	10	35
	3.7	3G3MX2-A2037-V1	3.0%	125%	Built-in Inverter		3G3AX-RBB4001	1	1	20	35
			10.0%	125%			3G3AX-RBC6001	1	1	10	35
	5.5	3G3MX2-A2055-V1	3.0%	120%	Built-in Inverter		3G3AX-RBB3001	2	2	30	20
			10.0%	120%			3G3AX-RBC4001	2	2	10	20
	7.5	3G3MX2-A2075-V1	3.0%	125%	Built-in Inverter		3G3AX-RBB4001	2	2	20	17
			10.0%	125%			3G3AX-RBC6001	2	2	10	17
	11	3G3MX2-A2110-V1	3.0%	90%	Built-in Inverter		3G3AX-RBC12001	1	1	10	17
			10.0%	90%			3G3AX-RBC12001	1	1	10	17
10.0%			125%	3G3AX-RBU23 *3			1	14	10	4	
15	3G3MX2-A2150-V1	3.0%	110%	Built-in Inverter		3G3AX-RBB3001	5	7	30	10	
		10.0%	110%			3G3AX-RBC4001	5	7	10	10	

Multi-function Compact Inverter MX2-Series V1 type

Inverter			Usage conditions		Regenerative braking unit		Braking resistor		Connection configuration	Restrictions	
Voltage	Max.applicable motor capacity (kW)	Model	%ED *1 [%]	Approximate braking torque [% *2]	Model	Number of units	Model	Number of units		Allowable continuous braking time(s)	Min. connectable resistance [Ω]
400-V Class	0.4	3G3MX2-A4004-V1	3.0%	220%	Built-in Inverter		3G3AX-RBA1201	2	3	20	180
			10.0%	220%			3G3AX-RBB2001	2		30	
	0.75	3G3MX2-A4007-V1	3.0%	220%	Built-in Inverter		3G3AX-RBA1201	2	3	20	180
			10.0%	220%			3G3AX-RBB2001	2		30	
	1.5	3G3MX2-A4015-V1	3.0%	120%	Built-in Inverter		3G3AX-RBA1201	2	3	20	180
			10.0%	120%			3G3AX-RBB2001	2		30	
	2.2	3G3MX2-A4022-V1	2.5%	150%	Built-in Inverter		3G3AX-RBA1202	2	3	12	100
			10.0%	220%			3G3AX-RBC4001	2		10	
	3.0	3G3MX2-A4030-V1	2.5%	110%	Built-in Inverter		3G3AX-RBA1202	2	3	12	100
			10.0%	215%			3G3AX-RBC4001	2		10	
	4.0	3G3MX2-A4040-V1	3.0%	165%	Built-in Inverter		3G3AX-RBB3001	2	3	30	100
			10.0%	165%			3G3AX-RBC4001	2		10	
	5.5	3G3MX2-A4055-V1	3.0%	120%	Built-in Inverter		3G3AX-RBB3001	2	3	30	70
			10.0%	120%			3G3AX-RBC4001	2		10	
	7.5	3G3MX2-A4075-V1	3.0%	125%	Built-in Inverter		3G3AX-RBB4001	2	3	20	70
			10.0%	125%			3G3AX-RBC6001	2		10	
	11	3G3MX2-A4110-V1	3.0%	85%	Built-in Inverter		3G3AX-RBB4001	2	3	20	70
			10.0%	85%			3G3AX-RBC6001	2		10	
10.0%			120%	3G3AX-RBU41*3			1	3G3AX-RBC4001		4	
15	3G3MX2-A4150-V1	3.0%	125%	Built-in Inverter		3G3AX-RBB4001	4	5	20	35	
		10.0%	125%			3G3AX-RBC6001	4		10		

*1 %ED shows the ratio that can be used for braking (deceleration time) among operating time of one task period.

*2 Approximate braking torque is shown in % of rating torque of the motor (100%).

*3 Please remove the built-in resistor.

Connection configuration

TYPE		
1	Resistor only One unit	
2	Resistor only Two units in parallel	
3	Resistor only Two units in series	
5	Resistor only Two parallel units connected in series to two other parallel units	

TYPE		
7	Resistor only Five units in parallel	
14	One braking unit Three resistors in parallel	
15	One braking unit Two resistors in parallel connected in series to two other parallel units	

Multi-function Compact Inverter MX2-Series V1 type

Name	Specifications of Inverter			Model	
	Voltage class	CT: Heavy load	VT: Light load		
Radio Noise Filter	3-phase 200 VAC	0.1 kW	0.2 kW	3G3AX-ZCL2	
		0.2 kW	0.4 kW		
		0.4 kW	0.75 kW		
		0.75 kW	1.1 kW		
		1.5 kW	2.2 kW		
		2.2 kW	3.0 kW		
		3.7 kW	5.5 kW		3G3AX-ZCL1 (3G3AX-ZCL2)
		5.5 kW	7.5 kW		
		7.5 kW	11 kW		3G3AX-ZCL1
		11 kW	15 kW		
	15 kW	18.5 kW			
	1-phase 200 VAC	0.1 kW	0.2 kW	3G3AX-ZCL2	
		0.2 kW	0.4 kW		
		0.4 kW	0.55 kW		
		0.75 kW	1.1 kW		
		1.5 kW	2.2 kW		
		2.2 kW	3.0 kW		
	3-phase 400 VAC	0.4 kW	0.75 kW	3G3AX-ZCL2 (3G3AX-ZCL1)	
		0.75 kW	1.5 kW		
		1.5 kW	2.2 kW		
		2.2 kW	3.0 kW		
		3.0 kW	4.0 kW		
		4.0 kW	5.5 kW		
		5.5 kW	7.5 kW		
		7.5 kW	11 kW		3G3AX-ZCL1
		11 kW	15 kW		
	15 kW	18.5 kW			
Input Noise Filter	3-phase 200 VAC	0.1 kW	0.2 kW	3G3AX-NFI21	
		0.2 kW	0.4 kW		
		0.4 kW	0.75 kW	3G3AX-NFI22	
		0.75 kW	1.1 kW		
		1.5 kW	2.2 kW	3G3AX-NFI23	
		2.2 kW	3.0 kW		
		3.7 kW	5.5 kW	3G3AX-NFI24	
		5.5 kW	7.5 kW		
		7.5 kW	11 kW	3G3AX-NFI26	
		11 kW	15 kW		
	15 kW	18.5 kW	3G3AX-NFI28		
	0.1 kW	0.2 kW		3G3AX-NFI21	
	0.2 kW	0.4 kW			
	0.4 kW	0.55 kW	3G3AX-NFI22		
	0.75 kW	1.1 kW			
	1.5 kW	2.2 kW	3G3AX-NFI23 *		
	2.2 kW	3.0 kW			
	1-phase 200 VAC	0.4 kW	0.75 kW	3G3AX-NFI41	
		0.75 kW	1.5 kW		
		1.5 kW	2.2 kW	3G3AX-NFI42	
		2.2 kW	3.0 kW		
		3.0 kW	4.0 kW	3G3AX-NFI43	
		4.0 kW	5.5 kW		
		5.5 kW	7.5 kW	3G3AX-NFI44	
		7.5 kW	11 kW		
		11 kW	15 kW	3G3AX-NFI45	
		15 kW	18.5 kW		
	3-phase 400 VAC	0.4 kW	0.75 kW	3G3AX-NFI41	
		0.75 kW	1.5 kW		
		1.5 kW	2.2 kW	3G3AX-NFI42	
2.2 kW		3.0 kW			
3.0 kW		4.0 kW	3G3AX-NFI43		
4.0 kW		5.5 kW			
5.5 kW		7.5 kW	3G3AX-NFI44		
7.5 kW		11 kW			
11 kW		15 kW	3G3AX-NFI45		
15 kW		18.5 kW			

* Only the CT rating is supported.

Multi-function Compact Inverter MX2-Series V1 type

Name	Specifications of Inverter			Model		
	Voltage class	CT: Heavy load	VT: Light load			
Output Noise Filter	3-phase 200 VAC	0.1 kW	0.2 kW	3G3AX-NFO01		
		0.2 kW	0.4 kW			
		0.4 kW	0.75 kW			
		1-phase 200 VAC	0.75 kW	1.1 kW	3G3AX-NFO02	
			1.5 kW	2.2 kW		
			2.2 kW	3.0 kW	3G3AX-NFO03	
			3.7 kW	5.5 kW		
			5.5 kW	7.5 kW		
			3-phase 400 VAC	7.5 kW	11 kW	3G3AX-NFO04
				11 kW	15 kW	
	15 kW			18.5 kW	3G3AX-NFO06	
	0.1 kW			0.2 kW		
	0.2 kW			0.4 kW		
	3-phase 200 VAC	0.4 kW		0.55 kW	3G3AX-NFO02	
		0.75 kW		1.1 kW		
		1.5 kW		2.2 kW	3G3AX-NFO03	
		2.2 kW		3.0 kW		
		3.0 kW		4.0 kW		
		1-phase 200 VAC	4.0 kW	5.5 kW	3G3AX-NFO03	
			5.5 kW	7.5 kW		
			7.5 kW	11 kW	3G3AX-NFO04	
			11 kW	15 kW		
			15 kW	18.5 kW		
	DC Reactor		3-phase 200 VAC	0.4 kW	0.75 kW	3G3AX-DL2007
0.75 kW				1.1 kW		
1.5 kW				2.2 kW	3G3AX-DL2022	
2.2 kW				3.0 kW		
3.7 kW				5.5 kW		
1-phase 200 VAC		5.5 kW		7.5 kW	3G3AX-DL2075	
		7.5 kW		11 kW		
		11 kW		15 kW	3G3AX-DL2110	
		15 kW		18.5 kW		
		0.1 kW		0.2 kW		3G3AX-DL2002
		0.2 kW	0.4 kW			
		3-phase 400 VAC	0.4 kW	0.55 kW	3G3AX-DL2007	
			0.75 kW	1.1 kW		
			1.5 kW	2.2 kW	3G3AX-DL2022	
			2.2 kW	3.0 kW		
3.0 kW			4.0 kW			
1-phase 200 VAC			4.0 kW	5.5 kW	3G3AX-DL2037	
			5.5 kW	7.5 kW		
			7.5 kW	11 kW	3G3AX-DL2150	
			11 kW	15 kW		
			15 kW	18.5 kW		
		3-phase 200 VAC	0.1 kW	0.2 kW	3G3AX-DL2002	
			0.2 kW	0.4 kW		
			0.4 kW	0.75 kW	3G3AX-DL2007	
			0.75 kW	1.1 kW		
			1.5 kW	2.2 kW		
1-phase 200 VAC			2.2 kW	3.0 kW	3G3AX-DL2037	
			3.0 kW	4.0 kW		
			4.0 kW	5.5 kW	3G3AX-DL2055	
			5.5 kW	7.5 kW		
	7.5 kW		11 kW			
	3-phase 400 VAC	11 kW	15 kW	3G3AX-DL2110		
		15 kW	18.5 kW			
		0.1 kW	0.2 kW	3G3AX-DL2002		
		0.2 kW	0.4 kW			
		0.4 kW	0.55 kW	3G3AX-DL2007		
0.75 kW		1.1 kW				
1.5 kW		2.2 kW				
1-phase 200 VAC		2.2 kW	3.0 kW	3G3AX-DL2037		
		3.0 kW	4.0 kW			
		4.0 kW	5.5 kW	3G3AX-DL2055		
	5.5 kW	7.5 kW				
	7.5 kW	11 kW				
	3-phase 400 VAC	11 kW	15 kW	3G3AX-DL2110		
		15 kW	18.5 kW			
		0.4 kW	0.75 kW	3G3AX-DL4007		
		0.75 kW	1.5 kW			
		1.5 kW	2.2 kW	3G3AX-DL4022		
2.2 kW		3.0 kW				
3.0 kW		4.0 kW				
1-phase 200 VAC		4.0 kW	5.5 kW	3G3AX-DL4037		
		5.5 kW	7.5 kW			
		7.5 kW	11 kW	3G3AX-DL4110 *		
	11 kW	15 kW				
	15 kW	18.5 kW				
	3-phase 400 VAC	0.4 kW	0.75 kW	3G3AX-DL4007		
		0.75 kW	1.5 kW			
		1.5 kW	2.2 kW	3G3AX-DL4022		
		2.2 kW	3.0 kW			
		3.0 kW	4.0 kW			
1-phase 200 VAC		4.0 kW	5.5 kW	3G3AX-DL4037		
		5.5 kW	7.5 kW			
		7.5 kW	11 kW	3G3AX-DL4110 *		
		11 kW	15 kW			
		15 kW	18.5 kW			
	3-phase 400 VAC	0.4 kW	0.75 kW	3G3AX-DL4007		
		0.75 kW	1.5 kW			
		1.5 kW	2.2 kW	3G3AX-DL4022		
		2.2 kW	3.0 kW			
		3.0 kW	4.0 kW			
1-phase 200 VAC		4.0 kW	5.5 kW	3G3AX-DL4037		
		5.5 kW	7.5 kW			
		7.5 kW	11 kW	3G3AX-DL4110 *		
		11 kW	15 kW			
		15 kW	18.5 kW			
	3-phase 400 VAC	0.4 kW	0.75 kW	3G3AX-DL4007		
		0.75 kW	1.5 kW			
		1.5 kW	2.2 kW	3G3AX-DL4022		
		2.2 kW	3.0 kW			
		3.0 kW	4.0 kW			
1-phase 200 VAC		4.0 kW	5.5 kW	3G3AX-DL4037		
		5.5 kW	7.5 kW			
		7.5 kW	11 kW	3G3AX-DL4110 *		
		11 kW	15 kW			
		15 kW	18.5 kW			

Multi-function Compact Inverter MX2-Series V1 type

Name	Specifications of Inverter			Model
	Voltage class	CT: Heavy load	VT: Light load	
AC Reactor	3-phase 200 VAC	0.1 kW	0.2 kW	3G3AX-AL2025
		0.2 kW	0.4 kW	
		0.4 kW	0.75 kW	
		0.75 kW	1.1 kW	
		1.5 kW	2.2 kW	3G3AX-AL2055
		2.2 kW	3.0 kW	3G3AX-AL2110
		3.7 kW	5.5 kW	3G3AX-AL2110 *
		5.5 kW	7.5 kW	3G3AX-AL2220
		7.5 kW	11 kW	3G3AX-AL2220 *
		11 kW	15 kW	3G3AX-AL2330
	15 kW	18.5 kW		
	1-phase 200 VAC	0.1 kW	0.2 kW	3G3AX-AL2025
		0.2 kW	0.4 kW	
		0.4 kW	0.55 kW	
		0.75 kW	1.1 kW	
		1.5 kW	2.2 kW	3G3AX-AL2055 *
		2.2 kW	3.0 kW	3G3AX-AL2110
	3-phase 400 VAC	0.4 kW	0.75 kW	3G3AX-AL4025
		0.75 kW	1.5 kW	3G3AX-AL4055
		1.5 kW	2.2 kW	
		2.2 kW	3.0 kW	
		3.0 kW	4.0 kW	3G3AX-AL4110
		4.0 kW	5.5 kW	
		5.5 kW	7.5 kW	3G3AX-AL4110 *
		7.5 kW	11 kW	3G3AX-AL4220
		11 kW	15 kW	3G3AX-AL4220 *
	15 kW	18.5 kW	3G3AX-AL4330	

* Only the CT rating is supported.

Note: When using the Inverter for light load rating, select the model with one size larger capacity (rated current).





Multi-function Compact Inverter MX2-Series V1 type

Name	Cable length(m)	Model
Digital Operator	–	3G3AX-OP01
Connection cable	1m	3G3AX-OPCN1
	3m	3G3AX-OPCN3

Recommended EtherCAT Communications Cables

Use Straight STP (shielded twisted-pair) cable of category 5 or higher with double shielding (braiding and aluminum foil tape) for EtherCAT.

Cabel with Connectors

Item	Appearance	Recommended manufacturer	Cable length(m) *1	Model
Standard type Cable with Connectors on Both Ends (RJ45/RJ45) Wire Gauge and Number of Pairs: AWG27, 4-pair Cable Cable Sheath material: LSZH *2 Cable color: Yellow *3		OMRON	0.3	XS6W-6LSZH8SS30CM-Y
			0.5	XS6W-6LSZH8SS50CM-Y
			1	XS6W-6LSZH8SS100CM-Y
			2	XS6W-6LSZH8SS200CM-Y
			3	XS6W-6LSZH8SS300CM-Y
			5	XS6W-6LSZH8SS500CM-Y
Rugged type Cable with Connectors on Both Ends (RJ45/RJ45) Wire Gauge and Number of Pairs: AWG22, 2-pair Cable		OMRON	0.3	XS5W-T421-AMD-K
			0.5	XS5W-T421-BMD-K
			1	XS5W-T421-CMD-K
			2	XS5W-T421-DMD-K
			5	XS5W-T421-GMD-K
Rugged type Cable with Connectors on Both Ends (M12 Straight/RJ45) Wire Gauge and Number of Pairs: AWG22, 2-pair Cable		OMRON	0.3	XS5W-T421-AMC-K
			0.5	XS5W-T421-BMC-K
			1	XS5W-T421-CMC-K
			2	XS5W-T421-DMC-K
			5	XS5W-T421-GMC-K
Rugged type Cable with Connectors on Both Ends (M12 Right-angle/RJ45) Wire Gauge and Number of Pairs: AWG22, 2-pair Cable		OMRON	0.3	XS5W-T422-AMC-K
			0.5	XS5W-T422-BMC-K
			1	XS5W-T422-CMC-K
			2	XS5W-T422-DMC-K
			5	XS5W-T422-GMC-K
			10	XS5W-T422-JMC-K

*1 Standard type cables length 0.2, 0.3, 0.5, 1, 1.5, 2, 3, 5, 7.5, 10, 15 and 20m are available.

Rugged type cables length 0.3, 0.5, 1, 2, 3, 5, 10 and 15m are available.

*2 The lineup features Low Smoke Zero Halogen cables for in-cabinet use and PUR cables for out-of-cabinet use.

*3 Cables colors are available in blue, yellow, or Green

Note: For details, refer to Cat.No.G019.

Cables / Connectors

Wire Gauge and Number of Pairs: AWG24, 4-pair Cable

Item	Appearance	Recommended manufacturer	Model
Cables	–	Hitachi Metals, Ltd.	NETSTAR-C5E SAB 0.5 x 4P *
	–	Kuramo Electric Co.	KETH-SB *
	–	SWCC Showa Cable Systems Co.	FAE-5004 *
RJ45 Connectors	–	Panduit Corporation	MPS588-C *

* We recommend you to use above cable and connector together.

Wire Gauge and Number of Pairs: AWG22, 2-pair Cable

Item	Appearance	Recommended manufacturer	Model
Cables	–	Kuramo Electric Co.	KETH-PSB-OMR *
	–	JMACS Japan Co., Ltd.	PNET/B *
RJ45 Assembly Connector		OMRON	XS6G-T421-1 *

* We recommend you to use above cable and connector together.

Note: Connect both ends of cable shielded wires to the connector hoods.

Software

How to Select Required Support Software for Your Controller

The required Support Software depends on the Controller to connect. Please check the following table when purchasing the Support Software.

Item	Omron PLC System	Omron Machine Automation Controller System
Controller	CS, CJ, CP, and other series	NJ/NX-series
Inverter	Inverter MX2-series V1 type Inverter MX2-series V1 type with EtherCAT Communication Unit (Applicable to the CJ series only.) Inverter MX2-series V1 type with CompoNet Communication Unit Inverter MX2-series V1 type with DeviceNet Communication Unit	Inverter MX2-series V1 type Inverter MX2-series V1 type with EtherCAT Communication Unit Inverter MX2-series V1 type with CompoNet Communication Unit Inverter MX2-series V1 type with DeviceNet Communication Unit
Software	FA Integrated Tool Package CX-One	Automation Software Sysmac Studio

FA Integrated Tool Package CX-One

Product name	Specifications			Model	Standards
		Number of licenses	Media		
FA Integrated Tool Package CX-One Ver. 4.□□	<p>The CX-One is a comprehensive software package that integrates Support Software for OMRON PLCs and components.</p> <p>CX-One runs on following OS. Windows XP (Service Pack 3 or higher, 32-bit version) / Windows Vista (32-bit/64-bit version) / Windows 7 (32-bit/64-bit version) / Windows 8 (32-bit/64-bit version) / Windows 8.1 (32-bit/64-bit version) / Windows 10 (32-bit/64-bit version)</p> <p>CX-One Version.4.□□ includes CX-Drive Ver.2.□□. For details, refer to the CX-One catalog (Cat. No. R134)</p>	1 license *	DVD	CXONE-AL01D-V4	-

* Multi licenses (3, 10, 30, or 50 licenses) and DVD media without licenses are also available for the CX-One.

Automation Software Sysmac Studio

Please purchase a DVD and required number of licenses the first time you purchase the Sysmac Studio. DVDs and licenses are available individually. Each model of licenses does not include any DVD.

Product name	Specifications			Model	Standards
		Number of licenses	Media		
Sysmac Studio Standard Edition Ver.1.□□□	<p>The Sysmac Studio provides an integrated development environment to set up, program, debug, and maintain NJ/NX-series Controllers and other Machine Automation Controllers, as well as EtherCAT slaves.</p> <p>Sysmac Studio runs on the following OS. Windows XP (Service Pack 3 or higher, 32-bit version) / Windows Vista (32-bit version) / Windows 7 (32-bit/64-bit version) / Windows 8 (32-bit/64-bit version) / Windows 8.1 (32-bit/64-bit version) / Windows 10 (32-bit/64-bit version)</p>	- (Media only)	DVD	SYSMAC-SE200D	-
	<p>The Sysmac Studio Standard Edition DVD includes Support Software to set up EtherNet/IP Units, DeviceNet slaves, Serial Communications Units, and Support Software for creating screens on HMIs (CX-Designer). For details, refer to the Sysmac Integrated Catalogue (P072).</p>	1 license *	-	SYSMAC-SE201L	-

* Multi licenses are available for the Sysmac Studio (3, 10, 30, or 50 licenses).

Overview of Inverter Selection

For detail of Inverter selection, refer to the MX2 series V1 type User's Manual. (Man.No.I585).

Motor Capacity Selection

Before selecting an inverter, first the motor should be chosen. In selecting the motor, first calculate the load inertia for the applications, and then calculate the required capacity and torque.

Make a simple selection (use Formulas for the required output power)

This method of calculation helps select a motor by calculating the output (W) required by the motor to maintain its regular rotations. It does not include calculation of the effect of acceleration/deceleration. Therefore, make allowance for the calculated value to select a motor. This calculation method can be applied to applications that operate constantly such as fans, conveyers, agitators etc.

This calculation method must not be applied to the following applications:

- Those requiring instant start-up.
- Those that frequently repeat operation and stop.
- Those that have a large inertia at the power transfer part.
- Those that have an inefficient power transfer part.

● For Straight-Line Operation: Normal Power P_o (kW)

$$P_o = \frac{\mu \cdot W \cdot V\ell}{6120 \cdot \eta}$$

μ : Friction Coefficient
 W : Mass of Straight-Line travelling part (kg)
 $V\ell$: Speed of Straight-Line Travelling part (m/min)
 η : Decelerator (Transfer part) Efficiency

● For Rotating Operation: Normal Power P_o (kW)

$$P_o \text{ (kW)} = \frac{2\pi \cdot T\ell \cdot N\ell}{60 \cdot \eta} \times 10^{-3}$$

$T\ell$: Load Torque (Load Shaft) (N-m)
 $N\ell$: Load Shaft Rotation Speed (r/min)
 η : Transfer part ($\eta \leq 1$)

Detailed Selection Method (R.M.S Algorithm)

This method helps to select a motor by calculating the effective torque and maximum torque required to achieve a certain pattern of operation for the application. It selects a motor that is optimal for a particular operation pattern.

● Calculate the inertia with a Motor Shaft Conversion Value

Calculate inertias of all the components with the formula for inertia calculation shown below to convert them to a motor conversion value.

$$J_w = J_1 + J_2 = \left(\frac{M_1 \cdot D^2}{8} + \frac{M_2 \cdot D^2}{4} \right) \times 10^{-6} \text{ (kg-m}^2\text{)}$$

J_w : Inertia (kg-m²)
 J_1 : Cylinder Inertia (kg-m²)
 J_2 : Inertia from Object (kg-m²)
 D : Diameter (mm)
 M_1 : Mass of Cylinder 1 (kg)
 M_2 : Mass of Object (kg)

$$J_w = J_1 + J_2 + J_3 + J_4 = \left(\frac{M_1 \cdot D_1^2}{8} + \frac{M_2 \cdot D_2^2}{8} \cdot \frac{D_2^2}{D_1^2} + \frac{M_3 \cdot D_1^2}{4} + \frac{M_4 \cdot D_1^2}{4} \right) \times 10^{-6} \text{ (kg-m}^2\text{)}$$

J_w : Inertia (kg-m²)
 J_1 : Cylinder 1 Inertia (kg-m²)
 J_2 : Inertia from Cylinder 2 (kg-m²)
 J_3 : Inertia from Object (kg-m²)
 J_4 : Inertia from Belt (kg-m²)
 D_1 : Cylinder 1 Diameter (mm)
 D_2 : Cylinder 2 Diameter (mm)
 M_1 : Mass of Cylinder 1 (kg)
 M_2 : Mass of Cylinder 2 (kg)
 M_3 : Mass of Object (kg)
 M_4 : Mass of Belt (kg)

$$J_w = J_1 + \left(\frac{D_1}{D_2} \right)^2 J_2 + \frac{M \cdot D_1^2}{4} \times 10^{-6} \text{ (kg-m}^2\text{)}$$

J_w : System Inertia (kg-m²)
 J_1 : Roller 1 Inertia (kg-m²)
 J_2 : Roller 2 Inertia (kg-m²)
 D_1 : Roller 1 Diameter (mm)
 D_2 : Roller 2 Diameter (mm)
 M : Work Equivalent Mass (kg)

$$J_L = J_1 + G^2 (J_2 + J_w) \text{ (kg-m}^2\text{)}$$

J_L : Load Inertia of Motor Shaft Conversion (kg-m²)
 J_w : Load Inertia (kg-m²)
 J_1 : Gear Inertia on Motor Side (kg-m²)
 J_2 : Gear Inertia on Load Side (kg-m²)
 Z_1 : Number of Gear Teeth on Motor Side
 Z_2 : Number of Gear Teeth on Load Side
 Gear Ratio $G = Z_1/Z_2$

● Calculate Motor Shaft Conversion Torque and Effective Torque

Calculate the acceleration torque from the load torque calculated from both the motor shaft conversion value and the motor rotor inertia. Then Combine this acceleration torque and the Load torque calculated from the friction force and the external force that are applied to the load. Now you get the required torque to operate a motor.

Acceleration Torque

$$T_A = \frac{2\pi N}{60 t_A} \left(J_M + \frac{J_L}{\eta} \right) \text{ (N-m)}$$

T_A : Acceleration/Deceleration Torque (N-m)
 J_L : Motor Shaft Conversion Load Inertia (kg-m²)
 J_M : Inertia of Motor Itself (kg-m²)
 η : Gear Transmission Efficiency
 N : Motor Rotation Speed (r/min)

Motor Shaft Conversion Load Torque (External Force/Friction)

$$T_w = F \cdot \frac{D}{2} \times 10^{-3} \text{ (N-m)}$$

F : External Force (N)
 T_w : Torque from External Force (N-m)

(Friction is generally,
 $F = \mu W$ μ : Friction Coefficient
 W : Mass of Moving Part)

$$T_L = T_w \cdot \frac{G}{\eta} \text{ (N-m)}$$

T_L : Motor Shaft Conversion Load Torque (N-m)
 T_w : Load Torque (N-m)
 Z_1 : Number of Gear Teeth on Motor Side
 Z_2 : Number of Gear Teeth on Load Side
 Gear (Deceleration) Ratio $G = Z_1/Z_2$

• Calculation of Total Torque and Effective Torque

Effective Torque: T_{RMS} (N·m)

$$= \sqrt{\frac{\sum (T_i)^2 \cdot t_i}{\sum t_i}} = \sqrt{\frac{T_1^2 \cdot t_1 + T_2^2 \cdot t_2 + T_3^2 \cdot t_3 + T_4^2 \cdot t_4}{t_1 + t_2 + t_3 + t_4}}$$

Maximum Torque: $T_{MAX} = T_1 = T_A + T_L$

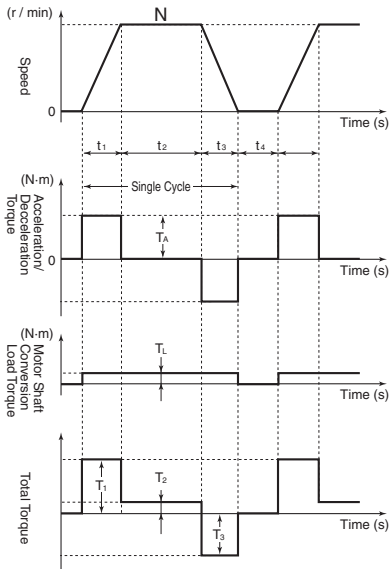

Note: Please make use of the Servo Motor selection software, which can calculate the motor shaft conversion inertia and effective/maximum torque, as above.

● Motor Selection

Use the formula below to calculate the motor capacity from the effective torque and the maximum torque that were obtained above. Select the larger of the two generated values as the motor capacity. Select a motor the capacity of which is larger than the calculated value and makes allowance for an error.

• Motor Capacity corresponding to Effective Torque

$$\text{Motor Capacity (kW)} = 1.048 \cdot N \cdot T_{RMS} \cdot 10^{-4}$$

N: Maximum Rotations (r/min)

• Motor Capacity capable of Providing Maximum Torque

$$\text{Motor Capacity (kW)} = 1.048 \cdot N \cdot T_{MAX} \cdot 10^{-4} / 1.5$$

N: Maximum Rotations (r/min)

Inverter Capacity Selection

Select an inverter that can be used for the selected motor in the process of "Motor Selection".

Generally, select an inverter which fits the maximum applicable motor capacity of the selected motor.

After selecting an inverter, check if it meets with all of the following conditions. If it does not, select an inverter that has a one class larger capacity and check the feasibility again.

Motor Rated Current ≤ Inverter Rated Output Current Maximum Time of Continuous Torque Output Time in an Application ≤ 1 minute

- Note:**
1. Where the inverter overload capacity is "120% of Rated Output Current for 1 minute", check it for 0.8 minute.
 2. Where a 0 Hz sensor-less vector control is being used, or where torque must be maintained for 0 (r/min) rotation speed and where 150% of the rated torque is frequently required, use an inverter which is one rank larger than the one selected by the above method.

Outline of Braking Resistor Selection

Importance of Braking Resistor

If the regenerative energy generated in deceleration or descent in an application is too great, the main circuit of an inverter may have an increased voltage and it may be damaged.

Because the inverter usually contains the overvoltage LAD stop function, it is not actually damaged. However, the motor stops detecting an error, making a stable and continuous operation disabled. Therefore, you must discharge the regenerative energy outside of the inverter.

● What is Regenerative Energy?

A load connected to a motor has kinetic energy when rotating, and potential energy when it is located in a high position. When the motor decelerates, or when the load descends, the energy is returned to an inverter. It is known as regeneration, and the energy generated by the phenomenon is known as regenerative energy.

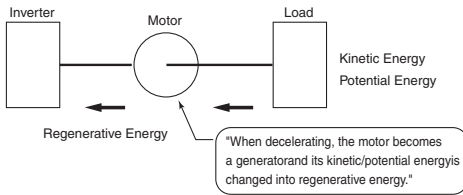

● Preventing Braking Resistance

The following are methods to prevent the connection of braking resistance.

These methods will make the deceleration time increase, so check if it will not cause problems.

- Enable the deceleration stall prevention (enabled in factory settings) (It will automatically increase deceleration time not to cause an overvoltage to stop the motor).
- Set a longer deceleration time. (Cause the regenerative energy to decrease per unit of time.)
- Disable Free-Run. (Prevent the regenerative energy from returning to an inverter.)

Make a Simple Selection for Braking Resistors

It can be a simple selecting method by using the ratio of time in which regenerative energy is produced in a normal operating pattern. Calculate the usage ratio from the following operating pattern.

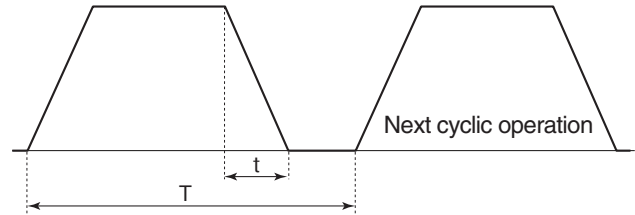

$$\text{Usage Rate} = t/T \times 100 (\% \text{ ED})$$

t : Deceleration Time (Regenerative Time)

T : Single Cycle Operation Time

%ED is the unit used for a usage rate.

The usage rate is used as the ratio of deceleration time (regenerative operation time) to simplify the selection of the braking options.

● For Models with a Built-in Braking Circuit (3G3MX2 Max. 22 kW)

Select the braking resistor based on the usage rate calculated from the operation patterns.

Refer to the braking resistor list described in the User's manual and catalog, and connect it according to your Inverter.

When the usage ratio for the braking resistor selected on the previous page exceeds 10% ED, or when an extremely large braking torque is required, use the method below to calculate a regenerative energy and make your selection.

● Calculation of Required Braking Resistor

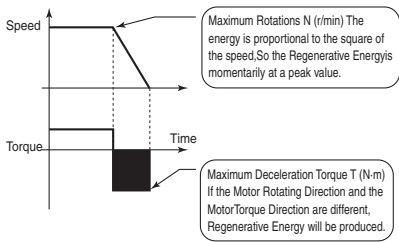

$$\text{Breaking Resistance Resistor: } R \leq \frac{V^2}{1.048 \times (T - 0.2 \times T_m) \times N \times 10^{-1}}$$

V: 200V class inverter 362.5 (V)

400V class inverter 725 (V)

T: Maximum Braking Torque (N·m)

T_m: Motor Rated Torque (N·m)

N: Maximum Rotation Speed (r/min)

Note: Calculate a braking torque using the above "Motor Capacity Selection".

● Calculation of Average Regenerative Energy

Regenerative Energy is produced when the motor rotation direction and the torque direction are opposite.

Use the following formula to calculate a regenerative energy per cycle interval.

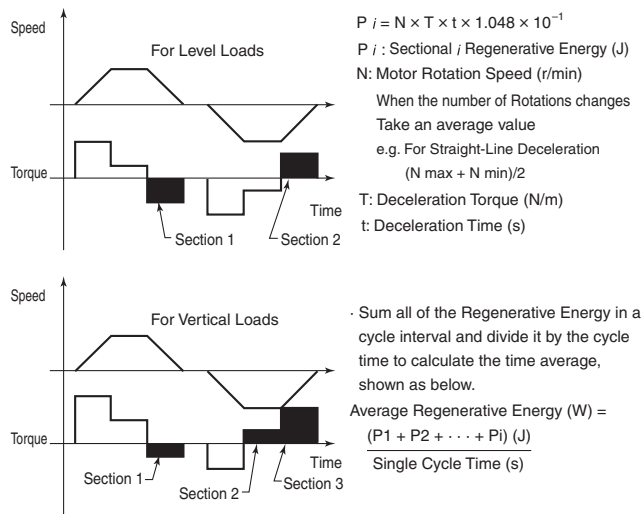

Note: 1. Forward rotation direction is forward for the speed, and the torque in the forward rotation direction is forward for the torque.

2. Calculate a braking torque using the above "Motor Capacity Selection".

● Braking Resistor Selection

Select a Braking Resistor from the required braking resistance and average regenerative energy on the left.

- Required Braking Resistance \geq Resistance of Braking Resistor \geq Minimum Connection Resistance of Inverter or Regenerative Braking Unit
- Average Regenerative Energy \leq Permissible Power for Braking Resistor

Note: 1. If a resistance that has a less than the minimum connectable value is connected on an inverter or regenerative braking resistor unit, the internal braking transistor can be damaged. When the required braking resistance is less than the minimum connectable resistance, change the inverter or regenerative energy braking to the one having a larger capacity and a minimum connection resistance less than the required braking resistance.

2. Two or more regenerative braking units can be operated in parallel. Refer to the following formula to know the braking resistance value in such a case.

Braking Resistance(Ω) = (Required Braking Resistance as calculated above) \times (No. of Units in use)

3. Do not use the above formula to select a generative braking resistance value. 150W does not reflect a permissible power capacity, but the maximum rated power per unit of resistance. The actual permissible power varies according to a resistance.

Multi-function Compact Inverter **MX2-Series V1 type**

Related Manuals

Man. No.	Model	Manual
I585	3G3MX2-□□□□□-V1	Multi-function Compact Inverter MX2 series V1 type USER'S MANUAL
I580		Drive Programming USER'S MANUAL
I570	3G3MX2-□□□□□	Multi-function Compact Inverter MX2-series USER'S MANUAL
I574	3G3AX-MX2-ECT	MX2 series / MX2 series V1 type/ RX series V1 type EtherCAT Communication Unit USER'S MANUAL
I581	3G3AX-MX2-DRT-E	MX2 series / MX2 series V1 type/ RX series V1 type DeviceNet Communication Unit USER'S MANUAL
I582	3G3AX-MX2-CRT-E	MX2 series / MX2 series V1 type/ RX series V1 type CompoNet Communication Unit USER'S MANUAL
W463	CXONE-AL□□D-V□	CX-One FA Integrated Tool Package Setup Manual
W453	CXONE-AL□□D-V□/WS02-DRVC01	CX-Drive OPERATION MANUAL
W504	SYSMAC-SE2□□□	Sysmac Studio Version 1 Operation Manual

Terms and Conditions of Sale

1. **Offer; Acceptance.** These terms and conditions (these "Terms") are deemed part of all quotes, agreements, purchase orders, acknowledgments, price lists, catalogs, manuals, brochures and other documents, whether electronic or in writing, relating to the sale of products or services (collectively, the "Products") by Omron Electronics LLC and its subsidiary companies ("Omron"). Omron objects to any terms or conditions proposed in Buyer's purchase order or other documents which are inconsistent with, or in addition to, these Terms.
2. **Prices; Payment Terms.** All prices stated are current, subject to change without notice by Omron. Omron reserves the right to increase or decrease prices on any unshipped portions of outstanding orders. Payments for Products are due net 30 days unless otherwise stated in the invoice.
3. **Discounts.** Cash discounts, if any, will apply only on the net amount of invoices sent to Buyer after deducting transportation charges, taxes and duties, and will be allowed only if (i) the invoice is paid according to Omron's payment terms and (ii) Buyer has no past due amounts.
4. **Interest.** Omron, at its option, may charge Buyer 1-1/2% interest per month or the maximum legal rate, whichever is less, on any balance not paid within the stated terms.
5. **Orders.** Omron will accept no order less than \$200 net billing.
6. **Governmental Approvals.** Buyer shall be responsible for, and shall bear all costs involved in, obtaining any government approvals required for the importation or sale of the Products.
7. **Taxes.** All taxes, duties and other governmental charges (other than general real property and income taxes), including any interest or penalties thereon, imposed directly or indirectly on Omron or required to be collected directly or indirectly by Omron for the manufacture, production, sale, delivery, importation, consumption or use of the Products sold hereunder (including customs duties and sales, excise, use, turnover and license taxes) shall be charged to and remitted by Buyer to Omron.
8. **Financial.** If the financial position of Buyer at any time becomes unsatisfactory to Omron, Omron reserves the right to stop shipments or require satisfactory security or payment in advance. If Buyer fails to make payment or otherwise comply with these Terms or any related agreement, Omron may (without liability and in addition to other remedies) cancel any unshipped portion of Products sold hereunder and stop any Products in transit until Buyer pays all amounts, including amounts payable hereunder, whether or not then due, which are owing to it by Buyer. Buyer shall in any event remain liable for all unpaid accounts.
9. **Cancellation; Etc.** Orders are not subject to rescheduling or cancellation unless Buyer indemnifies Omron against all related costs or expenses.
10. **Force Majeure.** Omron shall not be liable for any delay or failure in delivery resulting from causes beyond its control, including earthquakes, fires, floods, strikes or other labor disputes, shortage of labor or materials, accidents to machinery, acts of sabotage, riots, delay in or lack of transportation or the requirements of any government authority.
11. **Shipping; Delivery.** Unless otherwise expressly agreed in writing by Omron:
 - a. Shipments shall be by a carrier selected by Omron; Omron will not drop ship except in "break down" situations.
 - b. Such carrier shall act as the agent of Buyer and delivery to such carrier shall constitute delivery to Buyer;
 - c. All sales and shipments of Products shall be FOB shipping point (unless otherwise stated in writing by Omron), at which point title and risk of loss shall pass from Omron to Buyer; provided that Omron shall retain a security interest in the Products until the full purchase price is paid;
 - d. Delivery and shipping dates are estimates only; and
 - e. Omron will package Products as it deems proper for protection against normal handling and extra charges apply to special conditions.
12. **Claims.** Any claim by Buyer against Omron for shortage or damage to the Products occurring before delivery to the carrier must be presented in writing to Omron within 30 days of receipt of shipment and include the original transportation bill signed by the carrier noting that the carrier received the Products from Omron in the condition claimed.
13. **Warranties.** (a) **Exclusive Warranty.** Omron's exclusive warranty is that the Products will be free from defects in materials and workmanship for a period of twelve months from the date of sale by Omron (or such other period expressed in writing by Omron). Omron disclaims all other warranties, express or implied. (b) **Limitations.** OMRON MAKES NO WARRANTY OR REPRESENTATION, EXPRESS OR IMPLIED, ABOUT NON-INFRINGEMENT, MERCHANTABILITY OR FITNESS FOR A PARTICULAR PURPOSE OF THE PRODUCTS. BUYER ACKNOWLEDGES THAT IT ALONE HAS DETERMINED THAT THE PRODUCTS WILL SUITABLY MEET THE REQUIREMENTS OF THEIR INTENDED USE. Omron further disclaims all warranties and responsibility of any type for claims or expenses based on infringement by the Products or otherwise of any intellectual property right. (c) **Buyer Remedy.** Omron's sole obligation hereunder shall be, at Omron's election, to (i) replace (in the form originally shipped with Buyer responsible for labor charges for removal or replacement thereof) the non-complying Product, (ii) repair the non-complying Product, or (iii) repay or credit Buyer an amount equal to the purchase price of the non-complying Product; provided that in no event shall Omron be responsible for warranty, repair, indemnity or any other claims or expenses regarding the Products unless Omron's analysis confirms that the Products were properly handled, stored, installed and maintained and not subject to contamination, abuse, misuse or inappropriate modification. Return of any Products by Buyer must be approved in writing by Omron before shipment. Omron Companies shall not be liable for the suitability or unsuitability or the results from the use of Products in combination with any electrical or electronic components, circuits, system assemblies or any other materials or substances or environments. Any advice, recommendations or information given orally or in writing, are not to be construed as an amendment or addition to the above warranty. See <http://www.omron247.com> or contact your Omron representative for published information.
14. **Limitation on Liability; Etc.** OMRON COMPANIES SHALL NOT BE LIABLE FOR SPECIAL, INDIRECT, INCIDENTAL, OR CONSEQUENTIAL DAMAGES, LOSS OF PROFITS OR PRODUCTION OR COMMERCIAL LOSS IN ANY WAY CONNECTED WITH THE PRODUCTS, WHETHER SUCH CLAIM IS BASED IN CONTRACT, WARRANTY, NEGLIGENCE OR STRICT LIABILITY. Further, in no event shall liability of Omron Companies exceed the individual price of the Product on which liability is held.
15. **Indemnities.** Buyer shall indemnify and hold harmless Omron Companies and their employees from and against all liabilities, losses, claims, costs and expenses (including attorney's fees and expenses) related to any claim, investigation, litigation or proceeding (whether or not Omron is a party) which arises or is alleged to arise from Buyer's acts or omissions under these Terms or in any way with respect to the Products. Without limiting the foregoing, Buyer (at its own expense) shall indemnify and hold harmless Omron and defend or settle any action brought against such Companies to the extent based on a claim that any Product made to Buyer specifications infringed intellectual property rights of another party.
16. **Property; Confidentiality.** Any intellectual property in the Products is the exclusive property of Omron Companies and Buyer shall not attempt to duplicate it in any way without the written permission of Omron. Notwithstanding any charges to Buyer for engineering or tooling, all engineering and tooling shall remain the exclusive property of Omron. All information and materials supplied by Omron to Buyer relating to the Products are confidential and proprietary, and Buyer shall limit distribution thereof to its trusted employees and strictly prevent disclosure to any third party.
17. **Export Controls.** Buyer shall comply with all applicable laws, regulations and licenses regarding (i) export of products or information; (ii) sale of products to "forbidden" or other proscribed persons; and (iii) disclosure to non-citizens of regulated technology or information.
18. **Miscellaneous.** (a) **Waiver.** No failure or delay by Omron in exercising any right and no course of dealing between Buyer and Omron shall operate as a waiver of rights by Omron. (b) **Assignment.** Buyer may not assign its rights hereunder without Omron's written consent. (c) **Law.** These Terms are governed by the law of the jurisdiction of the home office of the Omron company from which Buyer is purchasing the Products (without regard to conflict of law principles). (d) **Amendment.** These Terms constitute the entire agreement between Buyer and Omron relating to the Products, and no provision may be changed or waived unless in writing signed by the parties. (e) **Severability.** If any provision hereof is rendered ineffective or invalid, such provision shall not invalidate any other provision. (f) **Setoff.** Buyer shall have no right to set off any amounts against the amount owing in respect of this invoice. (g) **Definitions.** As used herein, "including" means "including without limitation"; and "Omron Companies" (or similar words) mean Omron Corporation and any direct or indirect subsidiary or affiliate thereof.

Certain Precautions on Specifications and Use

1. **Suitability of Use.** Omron Companies shall not be responsible for conformity with any standards, codes or regulations which apply to the combination of the Product in the Buyer's application or use of the Product. At Buyer's request, Omron will provide applicable third party certification documents identifying ratings and limitations of use which apply to the Product. This information by itself is not sufficient for a complete determination of the suitability of the Product in combination with the end product, machine, system, or other application or use. Buyer shall be solely responsible for determining appropriateness of the particular Product with respect to Buyer's application, product or system. Buyer shall take application responsibility in all cases but the following is a non-exhaustive list of applications for which particular attention must be given: (i) Outdoor use, uses involving potential chemical contamination or electrical interference, or conditions or uses not described in this document. (ii) Use in consumer products or any use in significant quantities. (iii) Energy control systems, combustion systems, railroad systems, aviation systems, medical equipment, amusement machines, vehicles, safety equipment, and installations subject to separate industry or government regulations. (iv) Systems, machines and equipment that could present a risk to life or property. Please know and observe all prohibitions of use applicable to this Product. NEVER USE THE PRODUCT FOR AN APPLICATION INVOLVING SERIOUS RISK TO LIFE OR PROPERTY OR IN LARGE QUANTITIES WITHOUT ENSURING THAT THE SYSTEM AS A WHOLE HAS BEEN DESIGNED TO ADDRESS THE RISKS, AND THAT THE OMRON'S PRODUCT IS PROPERLY RATED AND INSTALLED FOR THE INTENDED USE WITHIN THE OVERALL EQUIPMENT OR SYSTEM.
2. **Programmable Products.** Omron Companies shall not be responsible for the user's programming of a programmable Product, or any consequence thereof.
3. **Performance Data.** Data presented in Omron Company websites, catalogs and other materials is provided as a guide for the user in determining suitability and does not constitute a warranty. It may represent the result of Omron's test conditions, and the user must correlate it to actual application requirements. Actual performance is subject to the Omron's Warranty and Limitations of Liability.
4. **Change in Specifications.** Product specifications and accessories may be changed at any time based on improvements and other reasons. It is our practice to change part numbers when published ratings or features are changed, or when significant construction changes are made. However, some specifications of the Product may be changed without any notice. When in doubt, special part numbers may be assigned to fix or establish key specifications for your application. Please consult with your Omron's representative at any time to confirm actual specifications of purchased Product.
5. **Errors and Omissions.** Information presented by Omron Companies has been checked and is believed to be accurate; however, no responsibility is assumed for clerical, typographical or proofreading errors or omissions.

OMRON AUTOMATION AMERICAS HEADQUARTERS • Chicago, IL USA • 847.843.7900 • 800.556.6766 • www.omron247.com

OMRON CANADA, INC. • HEAD OFFICE

Toronto, ON, Canada • 416.286.6465 • 866.986.6766 • www.omron247.com

OMRON ELECTRONICS DE MEXICO • HEAD OFFICE

México DF • 52.55.59.01.43.00 • 01-800-226-6766 • mela@omron.com

OMRON ELECTRONICS DE MEXICO • SALES OFFICE

Apodaca, N.L. • 52.81.11.56.99.20 • 01-800-226-6766 • mela@omron.com

OMRON ELETRÔNICA DO BRASIL LTDA • HEAD OFFICE

São Paulo, SP, Brasil • 55.11.2101.6300 • www.omron.com.br

OMRON ARGENTINA • SALES OFFICE

Cono Sur • 54.11.4783.5300

OMRON CHILE • SALES OFFICE

Santiago • 56.9.9917.3920

OTHER OMRON LATIN AMERICA SALES

54.11.4783.5300

OMRON EUROPE B.V. • Wegalaan 67-69, NL-2132 JD, Hoofddorp, The Netherlands. • +31 (0) 23 568 13 00 • www.industrial.omron.eu

Authorized Distributor:

Controllers & I/O

- Machine Automation Controllers (MAC) • Motion Controllers
- Programmable Logic Controllers (PLC) • Temperature Controllers • Remote I/O

Robotics

- Industrial Robots • Mobile Robots

Operator Interfaces

- Human Machine Interface (HMI)

Motion & Drives

- Machine Automation Controllers (MAC) • Motion Controllers • Servo Systems
- Frequency Inverters

Vision, Measurement & Identification

- Vision Sensors & Systems • Measurement Sensors • Auto Identification Systems

Sensing

- Photoelectric Sensors • Fiber-Optic Sensors • Proximity Sensors
- Rotary Encoders • Ultrasonic Sensors

Safety

- Safety Light Curtains • Safety Laser Scanners • Programmable Safety Systems
- Safety Mats and Edges • Safety Door Switches • Emergency Stop Devices
- Safety Switches & Operator Controls • Safety Monitoring/Force-guided Relays

Control Components

- Power Supplies • Timers • Counters • Programmable Relays
- Digital Panel Meters • Monitoring Products

Switches & Relays

- Limit Switches • Pushbutton Switches • Electromechanical Relays
- Solid State Relays

Software

- Programming & Configuration • Runtime

X-ON Electronics

Largest Supplier of Electrical and Electronic Components

Click to view similar products for [Inverters](#) category:

Click to view products by [Omron](#) manufacturer:

Other Similar products are found below :

[E5-652Z](#) [NL17SGU04P5T5G](#) [NLX2G04BMX1TCG](#) [CD4009UBE](#) [TC4584BFN](#) [022413E](#) [NL17SG14AMUTCG](#) [NLU2G04AMUTCG](#)
[NLU2GU04BMX1TCG](#) [NLU2G04CMX1TCG](#) [NLV17SZ06DFT2G](#) [TC74VHC04FK\(EL,K\)](#) [NLV74HC04ADTR2G](#) [NLU1G04AMUTCG](#)
[NLX2G04CMUTCG](#) [NLX2G04AMUTCG](#) [NLU1GU04CMUTCG](#) [NLU1GT14AMUTCG](#) [NLU1G04CMUTCG](#) [NL17SZU04P5T5G](#)
[74LVC06ADTR2G](#) [74LVC04ADR2G](#) [NLV37WZ04USG](#) [NLX3G14FMUTCG](#) [NL17SZ04P5T5G](#) [NLV17SG14DFT2G](#) [74ACT14SC](#)
[BU4069UBF-E2](#) [EMPP008Z](#) [NC7WZ14P6X](#) [NLV14106BDTR2G](#) [NLV74AC14DTR2G](#) [SN74HCT04DE4](#) [ODE-3-120023-1F12](#)
[74VHCT04AM](#) [SV004IE5-1C](#) [TC74HC04APF](#) [TC7SH04F,LJ\(CT](#) [TC7W14FK,LF](#) [74VHC14MTCX](#) [74LCX14MTC](#)
[SN74LVC1GU04DBVR](#) [NLU1G14BMX1TCG](#) [NLU2G04AMX1TCG](#) [NLU2G14AMX1TCG](#) [NLU3G14AMX1TCG](#) [NLVVHC1G04DFT2G](#)
[NLX2G04CMX1TCG](#) [NLX3G14AMX1TCG](#) [74HC14T14-13](#)