

Machine Automation Controller NX series

Flagship controller with industry's fastest processing speed *1 and large memory capacity for variables of up to 258 MB *2. Ideal for large-scale, fast, and highly-accurate control with up to 256 axes.



NX701-□□□□

Features

- Architecture based on Intel Core i7 quad-core processor for fast execution of double precision floating point arithmetic instructions as well as basic instructions.
- Integration of Logic and Motion in one CPU.
- Conforms to IEC 61131-3 (JIS B 3503) standard programming and PLCopen function blocks for Motion Control. Programming with variables allows users to create complex programs efficiently.
- Fast and accurate control by synchronizing all EtherCAT devices, such as vision sensors, servo drives, and field devices, with the PLC and Motion Engines.
- Two 1 Gbps EtherNet/IP ports embedded.
- Large-capacity memory for variables, up to 258 MB, enables data collection and analysis in parallel with device control.
- Offers speed without compromising on reliability and robustness expected from PLCs.
- Complete RAS functions: Transmission frame error check, timeout, bus diagnosis, Watchdog (WDT), memory check, and topology check, etc.

Ordering Information

International Standards

- The standards are abbreviated as follows: U: UL, U1: UL(Class I Division 2 Products for Hazardous Locations), C: CSA, UC: cULus, UC1: cULus (Class I Division 2 Products for Hazardous Locations), CU: cUL, N: NK, L: Lloyd, CE: EC Directives, RCM: Regulatory Compliance Mark, and KC: KC Registration.
- Contact your OMRON representative for further details and applicable conditions for these standards.

NX701 CPU Units

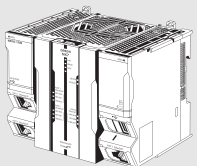
Product Name	Specifications			Current (Power) consumption	Model	Standards
	Program capacity	Memory capacity for variables	Number of motion axes			
 NX701 CPU Units	80 MB	4 MB: Retained during power interruption 256 MB: Not retained during power interruption	256	40 W (including SD Memory Card and End Cover)	NX701-1700	UC1, RCM, CE, KC
			128		NX701-1600	

*1. According to OMRON investigation in February 2015.

*2. The total number of bytes of retained and non-retained variables.

Sysmac is a trademark or registered trademark of OMRON Corporation in Japan and other countries for OMRON factory automation products. Intel, the Intel logo, Intel Core i7 are trademarks of Intel Corporation in the U.S. and/or other countries.

Windows is registered trademarks of Microsoft Corporation in the USA and other countries.

EtherCAT® is a registered trademark of Beckhoff Automation GmbH for their patented technology.

EtherNet/IP™, DeviceNet™ are trademarks of the ODVA.

Other company names and product names in this document are the trademarks or registered trademarks of their respective companies.

Recommended EtherCAT and EtherNet/IP Communications Cables





For EtherCAT, use a shielded twisted-pair cable (double shielding with aluminum tape and braiding) of Ethernet category 5 (100BASE-TX) or higher, and use straight wiring.

For EtherNet/IP, required specification for the communications cables varies depending on the baud rate.

For 100BASE-TX/10BASE-T, use an STP (shielded twisted-pair) cable of Ethernet category 5 or higher. You can use either a straight or cross cable. For 1000BASE-T, use an STP (double shielding with aluminum tape and braiding) cable of Ethernet category 5e or higher. You can use either a straight or cross cable.

In the table, materials indicated available for EtherNet/IP 100BASE-TX are available for both of 100BASE-TX and 10BASE-T.

Cable with Connectors

Item		Recommended manufacturer	Cable length (m) *1	Model
Products for EtherCAT	Standard type Category 6a Cable with Connectors on Both Ends (RJ45/RJ45) 	OMRON	0.3	XS6W-6LSZH8SS30CM-Y
			0.5	XS6W-6LSZH8SS50CM-Y
			1	XS6W-6LSZH8SS100CM-Y
			2	XS6W-6LSZH8SS200CM-Y
			3	XS6W-6LSZH8SS300CM-Y
			5	XS6W-6LSZH8SS500CM-Y
	Rugged type Category 5 Cable with Connectors on Both Ends (RJ45/RJ45) 	OMRON	0.3	XS5W-T421-AMD-K
			0.5	XS5W-T421-BMD-K
			1	XS5W-T421-CMD-K
			2	XS5W-T421-DMD-K
			5	XS5W-T421-GMD-K
			10	XS5W-T421-JMD-K
	Rugged type Category 5 Cable with Connectors on Both Ends (M12/RJ45) 	OMRON	0.3	XS5W-T421-AMC-K
			0.5	XS5W-T421-BMC-K
			1	XS5W-T421-CMC-K
			2	XS5W-T421-DMC-K
			5	XS5W-T421-GMC-K
			10	XS5W-T421-JMC-K
Rugged type Category 5 Cable with Connectors on Both Ends (M12 L/RJ45) 	OMRON	0.3	XS5W-T422-AMC-K	
		0.5	XS5W-T422-BMC-K	
		1	XS5W-T422-CMC-K	
		2	XS5W-T422-DMC-K	
			5	XS5W-T422-GMC-K
			10	XS5W-T422-JMC-K

*1. Standard type cables length 0.2, 0.3, 0.5, 1, 1.5, 2, 3, 5, 7.5, 10, 15 and 20m are available.

Rugged type cables length 0.3, 0.5, 1, 2, 3, 5, 10 and 15m are available.

*2. The lineup features Low Smoke Zero Halogen cables for in-cabinet use and PUR cables for out-of-cabinet use.

*3. Cables colors are available in blue, yellow, or Green

Note: For details, refer to Cat.No.G019.

Power Supply Units

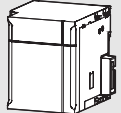
Product Name	Power supply voltage	Total power consumption	Output capacity	Options			Model	Standards
				24-VDC service power supply	RUN output	Maintenance forecast monitor		
AC Power Supply Unit 	100 to 240 VAC	150 VA	90 W	No	Yes	No	NX-PA9001	UC1, N, L, CE
DC Power Supply Unit	24 VDC	85 VA	70 W	No	Yes	No	NX-PD7001	

Cables / Connectors

Item		Recommended manufacturer	Model
EtherCAT or EtherNet/IP (100BASE-T/100BASE-TX)	Wire Gauge and Number of Pairs: AWG24, 4-pair Cable	Cables	Hitachi Metals, Ltd. NETSTAR-C5E SAB 0.5 × 4P *1
			Kuramo Electric Co. KETH-SB *1
			SWCC Showa Cable Systems Co. FAE-5004 *1
EtherCAT or EtherNet/IP (100BASE-TX)	Wire Gauge and Number of Pairs: AWG22, 2-pair Cable	RJ45 Connectors	Panduit Corporation MPS588-C *1
		Cables	Kuramo Electric Co. KETH-PSB-OMR *2
		RJ45 Assembly Connector	Nihon Electric Wire&Cable Co.,Ltd. PNET/B *2
		OMRON	XS6G-T421-1 *2
Products for EtherNet/IP (100BASE-TX)	Wire Gauge and Number of Pairs: 0.5 mm, 4-pair Cable	Cables	Fujikura Ltd. F-LINK-E 0.5mm × 4P *3
		RJ45 Connectors	Panduit Corporation MPS588 *3

- *1. We recommend you to use above cable for EtherCAT and EtherNet/IP, and RJ45 Connector together.
- *2. We recommend you to use above cable for EtherCAT and EtherNet/IP, and RJ45 Assembly Connector together.
- *3. We recommend you to use above cable For EtherNet/IP and RJ45 Connectors together.

Accessories

The following accessories come with the CPU Unit.

Item	Specification
Battery	CJ1W-BAT01
End Cover	NX-END01 (necessary to be connected to the right end of the CPU Rack.)
Fan Unit	NX-FAN01

General Specification

Item	NX701-□□□□	
Enclosure	Mounted in a panel	
Grounding method	Ground to less than 100 Ω	
Dimensions (height×depth×width)	100 mm × 100 mm × 132 mm	
Weight	880 g (including the End Cover)	
Power consumption	40 W (including SD Memory Card and End Cover)	
Operation environment	Ambient operating temperature	0 to 55°C
	Ambient operating humidity	10% to 90% (with no condensation)
	Atmosphere	Must be free from corrosive gases.
	Ambient storage temperature	-25 to 70°C (excluding battery)
	Altitude	2,000 m or less
	Pollution degree	2 or less: Conforms to JIS B3502 and IEC 61131-2.
	Noise immunity	2 kV on power supply line (Conforms to IEC 61000-4-4.)
	Overvoltage category	Category II: Conforms to JIS B3502 and IEC 61131-2.
	EMC immunity level	Zone B
	Vibration resistance	Conforms to IEC 60068-2-6. 5 to 8.4 Hz with 3.5-mm amplitude, 8.4 to 150 Hz Acceleration of 9.8 m/s ² for 100 min in X, Y, and Z directions (10 sweeps of 10 min each = 100 min total)
Shock resistance	Conforms to IEC 60068-2-27. 147 m/s ² , 3 times in X, Y, and Z directions (100 m/s ² for Relay Output Units)	
Battery	Life	2.5 years (at 25°C, Power ON time rate 0% (power OFF))
	Model	CJ1W-BAT01
Applicable standards	Conforms to cULus, NK, LR, EC Directives, RCM and KC Registration.	

Performance Specifications

Item			NX701-		
			1600	1700	
Processing time	Instruction execution times	LOAD instructions	0.42 ns		
		Math instructions (for Long Real Data)	3.2ns ns or more		
Programming	Program capacity *1	Size	80 MB		
		Number	POU definition	6,000	
			POU instance	48,000	
	Variables capacity	No Retain attribute	Size	256 MB	
			Number	360,000	
		Retain attribute	Size	4 MB	
Number	40,000				
Data type	Number	8,000			
Unit configuration	Maximum number of connectable Units	Maximum number of NX unit on the system	4000 (on NX series EtherCAT slave terminal)		
	Maximum number of expansion racks		0		
	Power supply unit for CPU rack and expansion racks	Model		NX-PA9001 NX-PD7001	
		Power OFF detection time	AC power supply	30 to 45 ms	
			DC power supply	5 to 20ms	
Motion control	Number of controlled axes	Maximum number of controlled axes *2	128 axes	256 axes	
		Maximum number of used real axes *3	128 axes	256 axes	
		Maximum number of axes for single-axis control	128 axes	256 axes	
		Maximum number of axes for linear interpolation axis control	4 axes per axes group		
		Number of axes for circular interpolation axis control	2 axes per axes group		
	Maximum number of axes groups		64 groups		
	Motion control period		The same control period as that is used for the process data communications cycle for EtherCAT.		
	Cams	Number of cam data points	Maximum points per cam table	65,535 points	
			Maximum points for all cam tables	1,048,560 points	
		Maximum number of cam tables		640 tables	
	Position units		Pulses, millimeters, micrometers, nanometers, degrees or inches		
Override factors		0.00% or 0.01% to 500.00%			
Peripheral USB port	Supported services		Sysmac Studio connection		
	Physical layer		USB 2.0-compliant B-type connector		
	Transmission distance between Hub and Node		5 m max.		
Built-in EtherNet/IP Port	Number of port		2		
	Physical layer		10BASE-T/100BASE-TX /1000BASE-T		
	Frame length		1514 max.		
	Media access method		CSMA/CD		
	Modulation		Baseband		
	Topology		Star		
	Baud rate		1Gbps (1000BASE-T)		
	Transmission media		STP (shielded, twisted-pair) cable of Ethernet category 5, 5e or higher		
	Maximum transmission distance between hub and node		100m		
Maximum number of cascade connections		There are no restrictions if a switching hub is used.			

*1. This is the capacity for the execution objects and variable tables (including variable names).

*2. This is the total for all axis types.

*3. This is the total number of axes that are set as servo axes or encoder axes and are also set as used axes.

Item		NX701-		
		1600	1700	
Built-in EtherNet/IP Port	CIP service: Tag Data Links (Cyclic Communications)	Maximum number of connections		256 / port total 512
		Packet interval *4		0.5 to 10,000 ms in 0.5-ms increments Can be set for each connection.
		Permissible communications band		40,000 pps *5 including heartbeat
		Maximum number of tag sets		256 / port total 512
		Tag types		Network variables
		Number of tags per connection (i.e., per tag set)		8 (7 tags if Controller status is included in the tag set.)
		Maximum number of tag		256 / port total 512
		Maximum link data size per node (total size for all tags)		369,664 byte
		Maximum data size per connection		1,444 byte
		Maximum number of registrable tag sets		256 / port total 512 (1 connection = 1 tag set)
	Maximum tag set size		1,444 bytes (Two bytes are used if Controller status is included in the tag set.)	
	Multi-cast packet filter *6		Supported.	
	Cip message service: Explicit messages	Class 3 (number of connections)		128 / port total 256 (clients plus server)
		UCMM (non-connection type)	Maximum number of clients that can communicate at one time	32 / port total 64
Maximum number of servers that can communicate at one time			32 / port total 64	
Maximum number of TCP socket service		30		
Built-in EtherCAT Port	Communications standard		IEC 61158 Type12	
	EtherCAT master specifications		Class B (Feature Pack Motion Control compliant)	
	Physical layer		100BASE-TX	
	Modulation		Baseband	
	Baud rate		100 Mbps (100Base-TX)	
	Duplex mode		Auto	
	Topology		Line, daisy chain, and branching	
	Transmission media		Twisted-pair cable of category 5 or higher (double-shielded straight cable with aluminum tape and braiding)	
	Maximum transmission distance between nodes		100m	
	Maximum number of slaves		512	
	Range of node address		1-512	
	Maximum process data size		Inputs: 11,472 bytes Outputs: 11,472 bytes	
	Maximum process data size per slave		Inputs: 1,434 bytes Outputs: 1,434 bytes	
	Communications cycle		<ul style="list-style-type: none"> Primary periodic task: 125 μs, 250 μs to 8 ms (in 250-μs increments) Priority-5 periodic task: 125 μs, 250 μs to 100 ms (in 250-μs increments) 	
Sync jitter		1 μs max.		
Internal clock		At ambient temperature of 55°C: -3.5 to +0.5 min error per month At ambient temperature of 25°C: -1.5 to +1.5 min error per month At ambient temperature of 0°C: -3 to +1 min error per month		

*4. Data is updated on the line in the specified interval regardless of the number of nodes.

*5. Means packets per second, i.e., the number of communications packets that can be sent or received in one second.

*6. An IGMP client is mounted for the EtherNet/IP port. If an ethernet switch that supports IGMP snooping is used, filtering of unnecessary multicast packets is performed.

Function Specifications

Item			NX701-□□□□		
Tasks	Function			I/O refreshing and the user program are executed in units that are called tasks. Tasks are used to specify execution conditions and execution priority.	
		Periodically executed tasks	Maximum number of primary periodic tasks	1	
			Maximum number of periodic tasks	4	
		Conditionally executed tasks	Maximum number of event tasks	32	
Execution conditions	When Activate Event Task instruction is executed or when condition expression for variable is met.				
Programming	POU (program organization units)	Programs		POUs that are assigned to tasks.	
		Function blocks		POUs that are used to create objects with specific conditions.	
		Functions		POUs that are used to create an object that determine unique outputs for the inputs, such as for data processing.	
	Programming languages	Types		Ladder diagrams * and structured text (ST)	
	Namespaces			A concept that is used to group identifiers for POU definitions.	
	Variables	External access of variables	Network variables	The function which allows access from the HMI, host computers, or other Controllers	
	Data types	Data types	Boolean	BOOL	
			Bit strings	BYTE, WORD, DWORD, LWORD	
			Integers	INT, SINT, DINT, LINT, UINT, USINT, UDINT, ULINT	
			Real numbers	REAL, LREAL	
			Durations	TIME	
			Dates	DATE	
			Times of day	TIME_OF_DAY	
			Date and time	DATE_AND_TIME	
		Text strings	STRING		
		Derivative data types		Structures, unions, enumerations	
		Structures	Function	A derivative data type that groups together data with different variable types.	
			Maximum number of members	2048	
			Nesting maximum levels	8	
	Member data types		Basic data types, structures, unions, enumerations, array variables		
Specifying member offsets	You can use member offsets to place structure members at any memory locations.				
Unions	Function	A derivative data type that groups together data with different variable types.			
	Maximum number of members	4			
	Member data types	BOOL, BYTE, WORD, DWORD, LWORD			
Enumerations	Function	A derivative data type that uses text strings called enumerators to express variable values.			
Data type attributes	Array specifications	Function	An array is a group of elements with the same data type. You specify the number (subscript) of the element from the first element to specify the element.		
		Maximum number of dimensions	3		
		Maximum number of elements	65535		
		Array specifications for FB Instances	Supported.		
	Range specifications		You can specify a range for a data type in advance. The data type can take only values that are in the specified range.		
Libraries			User libraries		

* Inline ST is supported. (Inline ST is ST that is written as an element in a ladder diagram.)

Item		NX701-□□□□	
Motion Control	Control modes		position control, velocity control, torque control
	Axis types		Servo axes, virtual servo axes, encoder axes, and virtual encoder axes
	Positions that can be managed		Command positions and actual positions
	Single-axis position control	Absolute positioning	Positioning is performed for a target position that is specified with an absolute value.
		Relative positioning	Positioning is performed for a specified travel distance from the command current position.
		Interrupt feeding	Positioning is performed for a specified travel distance from the position where an interrupt input was received from an external input.
		Cyclic synchronous absolute positioning	A positioning command is output each control period in Position Control Mode.
	Single-axis velocity control	Velocity control	Velocity control is performed in Position Control Mode.
		Cyclic synchronous velocity control	A velocity command is output each control period in Velocity Control Mode.
	Single-axis torque control	Torque control	The torque of the motor is controlled.
	Single-axis synchronized control	Starting cam operation	A cam motion is performed using the specified cam table.
		Ending cam operation	The cam motion for the axis that is specified with the input parameter is ended.
		Starting gear operation	A gear motion with the specified gear ratio is performed between a master axis and slave axis.
		Positioning gear operation	A gear motion with the specified gear ratio and sync position is performed between a master axis and slave axis.
		Ending gear operation	The specified gear motion or positioning gear motion is ended.
		Synchronous positioning	Positioning is performed in sync with a specified master axis.
		Master axis phase shift	The phase of a master axis in synchronized control is shifted.
	Single-axis manual operation	Combining axes	The command positions of two axes are added or subtracted and the result is output as the command position.
		Powering the servo	The Servo in the Servo Drive is turned ON to enable axis motion.
	Auxiliary functions for single-axis control	Jogging	An axis is jogged at a specified target velocity.
		Resetting axis errors	Axes errors are cleared.
		Homing	A motor is operated and the limit signals, home proximity signal, and home signal are used to define home.
		Homing with parameter	Specifying the parameter, a motor is operated and the limit signals, home proximity signal, and home signal are used to define home.
		High-speed homing	Positioning is performed for an absolute target position of 0 to return to home.
		Stopping	An axis is decelerated to a stop at the specified rate.
		Immediately stopping	An axis is stopped immediately.
		Setting override factors	The target velocity of an axis can be changed.
		Changing the current position	The command current position or actual current position of an axis can be changed to any position.
		Enabling external latches	The position of an axis is recorded when a trigger occurs.
		Disabling external latches	The current latch is disabled.
Zone monitoring		You can monitor the command position or actual position of an axis to see when it is within a specified range (zone).	
Enabling digital cam switches		You can turn a digital output ON and OFF according to the position of an axis.	
Monitoring axis following error		You can monitor whether the difference between the command positions or actual positions of two specified axes exceeds a threshold value.	
Resetting the following error		The error between the command current position and actual current position is set to 0.	
Torque limit	The torque control function of the Servo Drive can be enabled or disabled and the torque limits can be set to control the output torque.		
Command position compensation	The function which compensate the position for the axis in operation.		
Start velocity	You can set the initial velocity when axis motion starts.		

Item			NX701-□□□□		
Motion Control	Axes groups	Multi-axes coordinated control	Absolute linear interpolation	Linear interpolation is performed to a specified absolute position.	
			Relative linear interpolation	Linear interpolation is performed to a specified relative position.	
			Circular 2D interpolation	Circular interpolation is performed for two axes.	
			Axes group cyclic synchronous absolute positioning	A positioning command is output each control period in Position Control Mode.	
		Auxiliary functions for multi-axes coordinated control	Resetting axes group errors	Axes group errors and axis errors are cleared.	
			Enabling axes groups	Motion of an axes group is enabled.	
			Disabling axes groups	Motion of an axes group is disabled.	
			Stopping axes groups	All axes in interpolated motion are decelerated to a stop.	
			Immediately stopping axes groups	All axes in interpolated motion are stopped immediately.	
			Setting axes group override factors	The blended target velocity is changed during interpolated motion.	
			Reading axes group positions	The command current positions and actual current positions of an axes group can be read.	
			Changing the axes in an axes group	The Composition Axes parameter in the axes group parameters can be overwritten temporarily.	
		Common items	Cams	Setting cam table properties	The end point index of the cam table that is specified in the input parameter is changed.
				Saving cam tables	The cam table that is specified with the input parameter is saved in non-volatile memory in the CPU Unit.
	Generating cam tables			The cam table that is specified with the input parameter is generated from the cam property and cam node.	
	Parameters		Writing MC settings	Some of the axis parameters or axes group parameters are overwritten temporarily.	
			Changing axis parameters	You can access and change the axis parameters from the user program.	
	Auxiliary functions	Count modes		You can select either Linear Mode (finite length) or Rotary Mode (infinite length).	
		Unit conversions		You can set the display unit for each axis according to the machine.	
		Acceleration/ deceleration control	Automatic acceleration/ deceleration control	Jerk is set for the acceleration/deceleration curve for an axis motion or axes group motion.	
			Changing the acceleration and deceleration rates	You can change the acceleration or deceleration rate even during acceleration or deceleration.	
		In-position check		You can set an in-position range and in-position check time to confirm when positioning is completed.	
		Stop method		You can set the stop method to the immediate stop input signal or limit input signal.	
		Re-execution of motion control instructions		You can change the input variables for a motion control instruction during execution and execute the instruction again to change the target values during operation.	
		Multi-execution of motion control instructions (Buffer Mode)		You can specify when to start execution and how to connect the velocities between operations when another motion control instruction is executed during operation.	
		Continuous axes group motions (Transition Mode)		You can specify the Transition Mode for multi-execution of instructions for axes group operation.	
		Monitoring functions	Software limits		Software limits are set for each axis.
Following error			The error between the command current value and the actual current value is monitored for an axis.		
Velocity, acceleration rate, deceleration rate, torque, interpolation velocity, interpolation acceleration rate, and interpolation deceleration rate			You can set and monitor warning values for each axis and each axes group.		
Absolute encoder support		You can use an OMRON G5-Series Servomotor with an Absolute Encoder to eliminate the need to perform homing at startup.			
Input signal logic inversion		You can inverse the logic of immediate stop input signal, positive limit input signal, negative limit input signal, or home proximity input signal.			
External interface signals			The Servo Drive input signals listed on the right are used. Home signal, home proximity signal, positive limit signal, negative limit signal, immediate stop signal, and interrupt input signal		

Item		NX701-□□□□			
Unit (I/O) management	EtherCAT slaves	Maximum number of slaves	512		
Communications	Peripheral USB port		A port for communications with various kinds of Support Software running on a personal computer.		
	EtherNet/IP port	Communications protocol		TCP/IP, UDP/IP	
		CIP communications service	Tag data links	Programless cyclic data exchange is performed with the devices on the EtherNet/IP network.	
			Message communications	CIP commands are sent to or received from the devices on the EtherNet/IP network.	
		TCP/IP applications	Socket services		Data is sent to and received from any node on Ethernet using the UDP or TCP protocol. Socket communications instructions are used.
			FTP server		Files can be read from or written to the SD Memory Card in the CPU Unit from computers at other Ethernet nodes.
			FTP client		File can be read from or written to computers at other Ethernet nodes from the CPU Unit. FTP client communications instructions are used.
			Automatic clock adjustment		Clock information is read from the NTP server at the specified time or at a specified interval after the power supply to the CPU Unit is turned ON. The internal clock time in the CPU Unit is updated with the read time.
	SNMP agent		Built-in EtherNet/IP port internal status information is provided to network management software that uses an SNMP manager.		
	EtherCAT port	Supported services	Process data communications	A communications method to exchange control information in cyclic communications between the EtherCAT master and slaves. This communications method is defined by CoE.	
			SDO communications	A communications method to exchange control information in noncyclic event communications between EtherCAT master and slaves. This communications method is defined by CoE.	
		Network scanning		Information is read from connected slave devices and the slave configuration is automatically generated.	
		DC (distributed clock)		Time is synchronized by sharing the EtherCAT system time among all EtherCAT devices (including the master).	
		Packet monitoring		The frames that are sent by the master and the frames that are received by the master can be saved. The data that is saved can be viewed with WireShark or other applications.	
		Enable/disable settings for slaves		The slaves can be enabled or disabled as communications targets.	
		Disconnecting/connecting slaves		Temporarily disconnects a slave from the EtherCAT network for maintenance, such as for replacement of the slave, and then connects the slave again.	
		Supported application protocol	CoE	SDO messages of the CAN application can be sent to slaves via EtherCAT.	
Communications instructions			The following instructions are supported. CIP communications instructions, socket communications instructions, SDO message instructions, FTP client instructions		
Operation management	RUN output contacts		The output on the Power Supply Unit turns ON in RUN mode.		

Item			NX701-□□□□		
System management	Event logs	Categories	Events are recorded in the following logs. System event log Access event log User-defined event log		
		Maximum number of events per event log	1,024		
Debugging	Online editing	Single	Programs, function blocks, functions, and global variables can be changed online. Different operators can change different POU's across a network.		
	Forced refreshing	The user can force specific variables to TRUE or FALSE.			
		Maximum number of forced variables	Device variables for EtherCAT slaves	64	
	MC test run	Motor operation and wiring can be checked from the Sysmac Studio.			
	Synchronizing	The project file in the Sysmac Studio and the data in the CPU Unit can be made the same when online.			
	Differentiation monitoring	Rising/falling edge of contacts can be monitored.			
		Maximum number of contacts		8	
	Data tracing	Types	Single triggered trace	When the trigger condition is met, the specified number of samples are taken and then tracing stops automatically.	
			Continuous trace	Data tracing is executed continuously and the trace data is collected by the Sysmac Studio.	
		Maximum number of simultaneous data trace		4	
		Maximum number of records		10,000	
		Sampling	Maximum number of sampled variables	192 variables	
		Timing of sampling		Sampling is performed for the specified task period, at the specified time, or when a sampling instruction is executed.	
		Triggered traces	Trigger conditions are set to record data before and after an event.		
			Trigger conditions		When BOOL variable changes to TRUE or FALSE Comparison of non-BOOL variable with a constant Comparison Method: Equals (=), Greater than (>), Greater than or equals (≥), Less Than (<), Less than or equals (≤), Not equal (≠)
Delay			Trigger position setting: A slider is used to set the percentage of sampling before and after the trigger condition is met.		
Simulation			The operation of the CPU Unit is emulated in the Sysmac Studio.		
Reliability functions	Self-diagnosis	Controller errors	Levels		
		Major fault, partial fault, minor fault, observation, and information			
		User-defined errors			
		Levels	8 levels		
Security	Protecting software assets and preventing operating mistakes	CPU Unit names and serial IDs		When going online to a CPU Unit from the Sysmac Studio, the CPU Unit name in the project is compared to the name of the CPU Unit being connected to.	
		Protection	User program transfer with no restoration information	You can prevent reading data in the CPU Unit from the Sysmac Studio.	
			CPU unit write protection	You can prevent writing data to the CPU Unit from the Sysmac Studio or SD Memory Card.	
			Overall project file protection	You can use passwords to protect .smc files from unauthorized opening on the Sysmac Studio.	
			Data protection	You can use passwords to protect POU's on the Sysmac Studio.	
		Verification of operation authority		Online operations can be restricted by operation rights to prevent damage to equipment or injuries that may be caused by operating mistakes.	
				Number of groups	5
Verification of user program execution ID			The user program cannot be executed without entering a user program execution ID from the Sysmac Studio for the specific hardware (CPU Unit).		

Item		NX701-□□□□		
SD memory card functions	Storage Type	SD Memory Card, SDHC Memory Card		
	Application	Automatic transfer from SD memory card	The data in the autoloader folder on an SD Memory Card is automatically loaded when the power supply to the Controller is turned ON.	
		SD memory card operation instructions	You can access SD Memory Cards from instructions in the user program.	
		File operations from the Sysmac Studio	You can perform file operations for Controller files in the SD Memory Card and read/write standard document files on the computer.	
	SD memory card life expiration detection	Notification of the expiration of the life of the SD Memory Card is provided in a system-defined variable and event log.		
Backup functions	SD memory card backup functions	Operation	Using front switch	You can use front switch to backup, compare, or restore data.
			Using system-defined variables	You can use system-defined variables to backup or compare data.
			Memory card operations dialog box on Sysmac Studio	Backup and verification operations can be performed from the SD Memory Card Operations Dialog Box on the Sysmac Studio.
		Using instruction	Backup operation can be performed by using instruction.	
	Protection	Prohibiting backing up data to the SD memory card	Prohibit SD Memory Card backup functions.	
Sysmac Studio Controller backup functions		Backup, restore, and verification operations for Units can be performed from the Sysmac Studio.		

Unit Versions

Units	Models	Unit Version
NX701 CPU Units	NX701-□□□□	Unit version 1.10

Unit Versions and Corresponding Sysmac Studio Versions

The following table gives the relationship between unit versions of CPU Units and the corresponding Sysmac Studio versions.

Unit version of CPU Unit	Corresponding version of Sysmac Studio
1.10	1.13

External Interface

An NX701 CPU Unit (NX701-□□□□) provides three communications ports for external interfaces: a peripheral USB port, a built-in EtherNet/IP port and a built-in EtherCAT port.

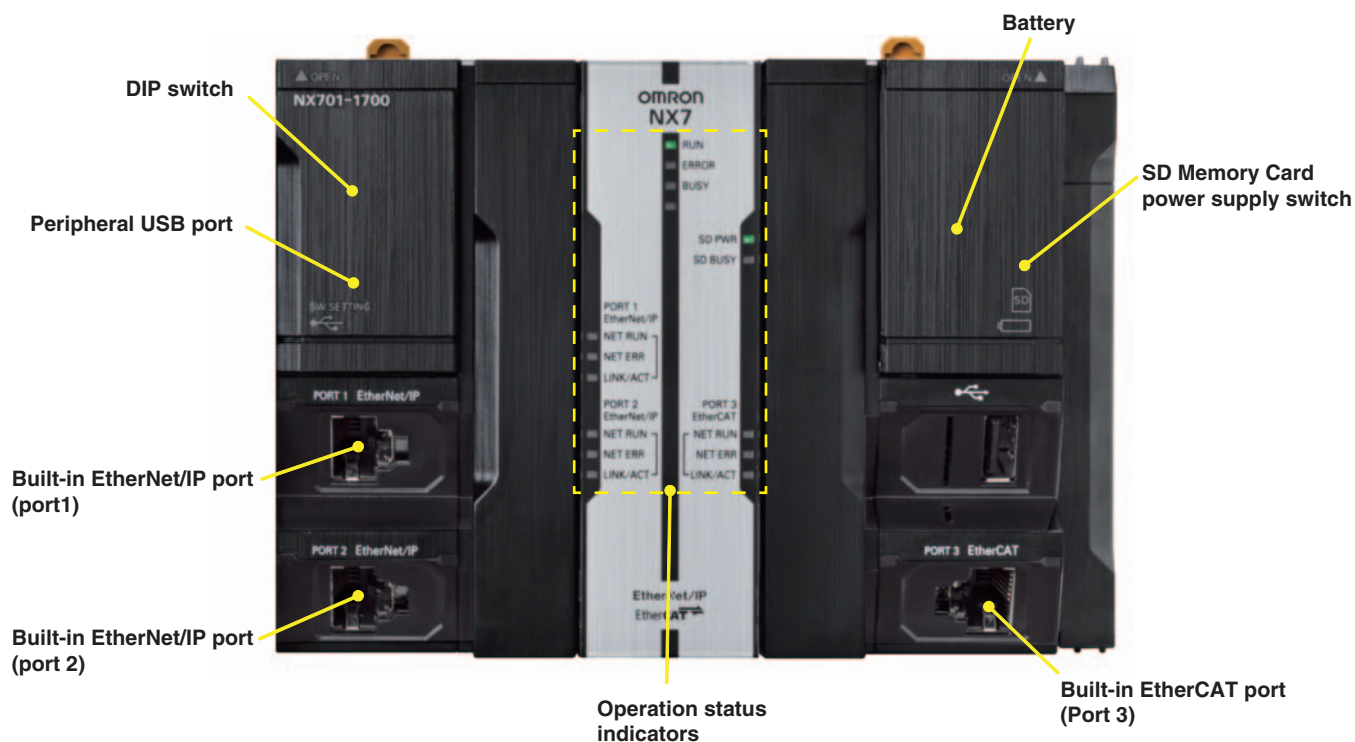

Peripheral USB Port

Item	Specification
Physical layer	USB 2.0-compliant B-type connector
Transmission distance	5 m max.

Use commercially available USB cables.

Specification: USB 2.0 (or 1.1) cable (A connector - B connector), 5.0 m max.

Built-in EtherNet/IP Port

Item	Specification
Physical layer	10BASE-T/100BASE-TX/1000BASE-T
Media access method	CSMA/CD
Modulation	Baseband
Topology	Star
Baud rate	1 Gbps (1000BASE-T)
Transmission media	Straight or cross STP (shielded twisted-pair) cable of category 5 or higher.
Transmission distance	100 m max. (distance between ethernet switch and node)

You can connect Sysmac Studio with built-in EtherNet/IP port.

Built-in EtherCAT Port

Item	Specification
Synchronization	DC (distributed clock)
Physical layer	100BASE-TX
Modulation	Baseband
Baud rate	100 Mbps (100BASE-TX).
Duplex mode	Automatic
Topology	Line, daisy chain and branching
Transmission media	Shielded twisted-pair (STP); Category 5 or higher straight cable with double shielding (braiding and aluminum foil tape)
Transmission distance	100 m max. between nodes

Dimensions

NX701 CPU Units (NX701-□□□□)

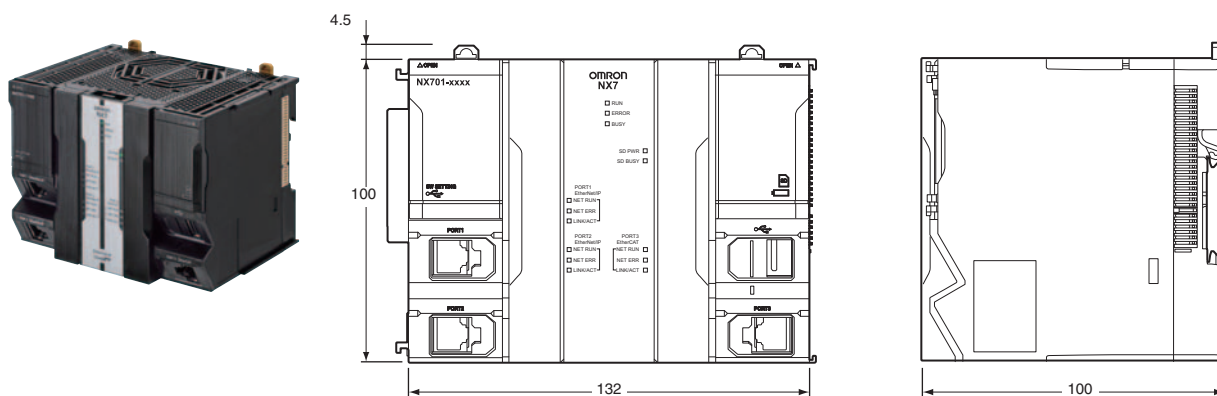

When a cable is connected (such as a communications cable)

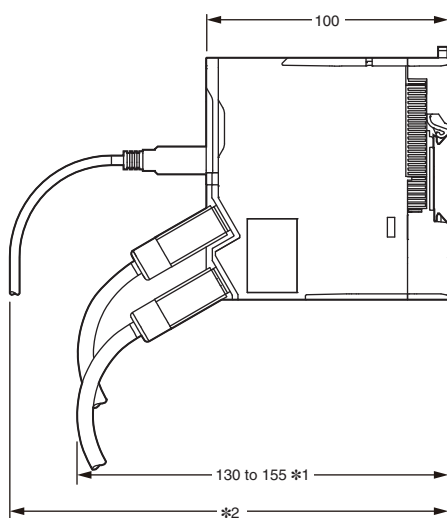

- *1. This is the dimension from the back of the Unit to the communications cables.
 130 mm: When an MPS588-C Connector is used.
 155 mm: When an XS6G-T421-1 Connector is used.
- *2. This dimension depends on the specifications of the commercially available USB cable. Check the specifications of the USB cable that is used.

End Cover (NX-END01)

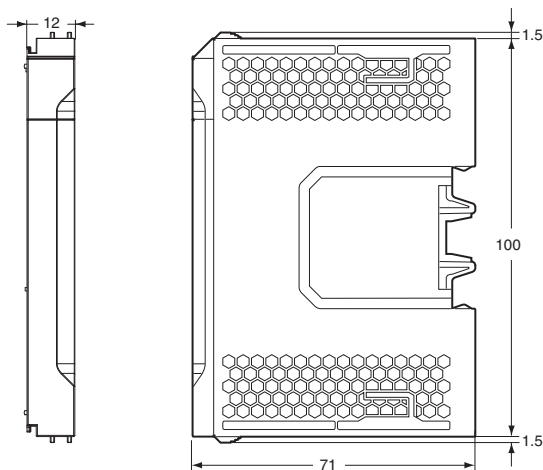

Related Manuals

Cat. No.	Model number	Manual	Application	Description
W535	NX701-□□□□	NX-series CPU Unit Hardware User's Manual	Learning the basic specifications of the NX-series CPU Units, including introductory information, designing, installation, and maintenance. Mainly hardware information is provided.	An introduction to the entire NX-series system is provided along with the following information on a Controller built with a CPU Unit. <ul style="list-style-type: none"> • Features and system configuration • Introduction • Part names and functions • General specifications • Installation and wiring • Maintenance and inspection Use this manual together with the <i>NJ/NX-series CPU Unit Software User's Manual</i> (Cat. No. W501).
W501	NX701-□□□□ NJ501-□□□□ NJ301-□□□□ NJ101-□□□□	NJ/NX-series CPU Unit Software User's Manual	Learning how to program and set up an NJ/NX-series CPU Unit. Mainly software information is provided.	The following information is provided on a Controller built with an NJ/NX-series CPU Unit. <ul style="list-style-type: none"> • CPU Unit operation • CPU Unit features • Initial settings • Programming based on IEC 61131-3 language specifications Use this manual together with the <i>NX-series CPU Unit Hardware User's Manual</i> (Cat. No. W535).
W502	NX701-□□□□ NJ501-□□□□ NJ301-□□□□ NJ101-□□□□	NJ/NX-series Instructions Reference Manual	Learning detailed specifications on the basic instructions of an NJ/NX-series CPU Unit.	The instructions in the instruction set IEC 61131-3 specifications) are described. When programming, use this manual together with the <i>NX-series CPU Unit Hardware User's Manual</i> (Cat. No. W535) and <i>NJ/NX-series CPU Unit Software User's Manual</i> (Cat. No. W501).
W507	NX701-□□□□ NJ501-□□□□ NJ301-□□□□ NJ101-□□□□	NJ/NX-series CPU Unit Motion Control User's Manual	Learning about motion control settings and programming concepts.	The settings and operation of the CPU Unit and programming concepts for motion control are described. When programming, use this manual together with the <i>NX-series CPU Unit Hardware User's Manual</i> (Cat. No. W535) and <i>NJ/NX-series CPU Unit Software User's Manual</i> (Cat. No. W501).
W508	NX701-□□□□ NJ501-□□□□ NJ301-□□□□ NJ101-□□□□	NJ/NX-series Motion Control Instructions Reference Manual	Learning about the specifications of the motion control instructions that are provided by OMRON.	The motion control instructions are described. When programming, use this manual together with the <i>NX-series CPU Unit Hardware User's Manual</i> (Cat. No. W535), <i>NJ/NX-series CPU Unit Software User's Manual</i> (Cat. No. W501) and <i>NJ/NX-series CPU Unit Motion Control User's Manual</i> (Cat. No. W507).
W505	NX701-□□□□ NJ501-□□□□ NJ301-□□□□ NJ101-□□□□	NJ/NX-series CPU Unit Built-in EtherCAT® Port User's Manual	Using the built-in EtherCAT port on an NJ/NX-series CPU Unit.	Information on the built-in EtherCAT port is provided. This manual provides an introduction and provides information on the configuration, features, and setup. Use this manual together with the <i>NX-series CPU Unit Hardware User's Manual</i> (Cat. No. W535) and <i>NJ/NX-series CPU Unit Software User's Manual</i> (Cat. No. W501).
W506	NX701-□□□□ NJ501-□□□□ NJ301-□□□□ NJ101-□□□□	NJ/NX-series CPU Unit Built-in EtherNet/IP™ port User's Manual	Using the built-in EtherNet/IP port on an NJ/NX-series CPU Unit.	Information on the built-in EtherNet/IP port is provided. Information is provided on the basic setup, tag data links, and other features. Use this manual together with the <i>NX-series CPU Unit Hardware User's Manual</i> (Cat. No. W535) and <i>NJ/NX-series CPU Unit Software User's Manual</i> (Cat. No. W501).
W503	NX701-□□□□ NJ501-□□□□ NJ301-□□□□ NJ101-□□□□	NJ/NX-series Troubleshooting Manual	Learning about the errors that may be detected in an NJ/NX-series Controller.	Describes concepts on managing errors that may be detected in an NJ/NX-series Controller and information on individual errors. Use this manual together with the <i>NX-series CPU Unit Hardware User's Manual</i> (Cat. No. W535) and <i>NJ/NX-series CPU Unit Software User's Manual</i> (Cat. No. W501).
W504	SYSMAC-SE2□□□□	Sysmac Studio Version 1 Operation Manual	Learning about the operating procedures and functions of the Sysmac Studio.	Describes the operating procedures of the Sysmac Studio.

Terms and Conditions of Sale

1. **Offer; Acceptance.** These terms and conditions (these "**Terms**") are deemed part of all quotes, agreements, purchase orders, acknowledgments, price lists, catalogs, manuals, brochures and other documents, whether electronic or in writing, relating to the sale of products or services (collectively, the "**Products**") by Omron Electronics LLC and its subsidiary companies ("**Omron**"). Omron objects to any terms or conditions proposed in Buyer's purchase order or other documents which are inconsistent with, or in addition to, these Terms.
2. **Prices; Payment Terms.** All prices stated are current, subject to change without notice by Omron. Omron reserves the right to increase or decrease prices on any unshipped portions of outstanding orders. Payments for Products are due net 30 days unless otherwise stated in the invoice.
3. **Discounts.** Cash discounts, if any, will apply only on the net amount of invoices sent to Buyer after deducting transportation charges, taxes and duties, and will be allowed only if (i) the invoice is paid according to Omron's payment terms and (ii) Buyer has no past due amounts.
4. **Interest.** Omron, at its option, may charge Buyer 1-1/2% interest per month or the maximum legal rate, whichever is less, on any balance not paid within the stated terms.
5. **Orders.** Omron will accept no order less than \$200 net billing.
6. **Governmental Approvals.** Buyer shall be responsible for, and shall bear all costs involved in, obtaining any government approvals required for the importation or sale of the Products.
7. **Taxes.** All taxes, duties and other governmental charges (other than general real property and income taxes), including any interest or penalties thereon, imposed directly or indirectly on Omron or required to be collected directly or indirectly by Omron for the manufacture, production, sale, delivery, importation, consumption or use of the Products sold hereunder (including customs duties and sales, excise, use, turnover and license taxes) shall be charged to and remitted by Buyer to Omron.
8. **Financial.** If the financial position of Buyer at any time becomes unsatisfactory to Omron, Omron reserves the right to stop shipments or require satisfactory security or payment in advance. If Buyer fails to make payment or otherwise comply with these Terms or any related agreement, Omron may (without liability and in addition to other remedies) cancel any unshipped portion of Products sold hereunder and stop any Products in transit until Buyer pays all amounts, including amounts payable hereunder, whether or not then due, which are owing to it by Buyer. Buyer shall in any event remain liable for all unpaid accounts.
9. **Cancellation; Etc.** Orders are not subject to rescheduling or cancellation unless Buyer indemnifies Omron against all related costs or expenses.
10. **Force Majeure.** Omron shall not be liable for any delay or failure in delivery resulting from causes beyond its control, including earthquakes, fires, floods, strikes or other labor disputes, shortage of labor or materials, accidents to machinery, acts of sabotage, riots, delay in or lack of transportation or the requirements of any government authority.
11. **Shipping; Delivery.** Unless otherwise expressly agreed in writing by Omron:
 - a. Shipments shall be by a carrier selected by Omron; Omron will not drop ship except in "break down" situations.
 - b. Such carrier shall act as the agent of Buyer and delivery to such carrier shall constitute delivery to Buyer;
 - c. All sales and shipments of Products shall be FOB shipping point (unless otherwise stated in writing by Omron), at which point title and risk of loss shall pass from Omron to Buyer; provided that Omron shall retain a security interest in the Products until the full purchase price is paid;
 - d. Delivery and shipping dates are estimates only; and
 - e. Omron will package Products as it deems proper for protection against normal handling and extra charges apply to special conditions.
12. **Claims.** Any claim by Buyer against Omron for shortage or damage to the Products occurring before delivery to the carrier must be presented in writing to Omron within 30 days of receipt of shipment and include the original transportation bill signed by the carrier noting that the carrier received the Products from Omron in the condition claimed.
13. **Warranties.** (a) **Exclusive Warranty.** Omron's exclusive warranty is that the Products will be free from defects in materials and workmanship for a period of twelve months from the date of sale by Omron (or such other period expressed in writing by Omron). Omron disclaims all other warranties, express or implied. (b) **Limitations.** OMRON MAKES NO WARRANTY OR REPRESENTATION, EXPRESS OR IMPLIED, ABOUT NON-INFRINGEMENT, MERCHANTABILITY OR FITNESS FOR A PARTICULAR PURPOSE OF THE PRODUCTS. BUYER ACKNOWLEDGES THAT IT ALONE HAS DETERMINED THAT THE PRODUCTS WILL SUITABLY MEET THE REQUIREMENTS OF THEIR INTENDED USE. Omron further disclaims all warranties and responsibility of any type for claims or expenses based on infringement by the Products or otherwise of any intellectual property right. (c) **Buyer Remedy.** Omron's sole obligation hereunder shall be, at Omron's election, to (i) replace (in the form originally shipped with Buyer responsible for labor charges for removal or replacement thereof) the non-complying Product, (ii) repair the non-complying Product, or (iii) repay or credit Buyer an amount equal to the purchase price of the non-complying Product; provided that in no event shall Omron be responsible for warranty, repair, indemnity or any other claims or expenses regarding the Products unless Omron's analysis confirms that the Products were properly handled, stored, installed and maintained and not subject to contamination, abuse, misuse or inappropriate modification. Return of any Products by Buyer must be approved in writing by Omron before shipment. Omron Companies shall not be liable for the suitability or unsuitability or the results from the use of Products in combination with any electrical or electronic components, circuits, system assemblies or any other materials or substances or environments. Any advice, recommendations or information given orally or in writing, are not to be construed as an amendment or addition to the above warranty. See <http://www.omron247.com> or contact your Omron representative for published information.
14. **Limitation on Liability; Etc.** OMRON COMPANIES SHALL NOT BE LIABLE FOR SPECIAL, INDIRECT, INCIDENTAL, OR CONSEQUENTIAL DAMAGES, LOSS OF PROFITS OR PRODUCTION OR COMMERCIAL LOSS IN ANY WAY CONNECTED WITH THE PRODUCTS, WHETHER SUCH CLAIM IS BASED IN CONTRACT, WARRANTY, NEGLIGENCE OR STRICT LIABILITY. Further, in no event shall liability of Omron Companies exceed the individual price of the Product on which liability is asserted.
15. **Indemnities.** Buyer shall indemnify and hold harmless Omron Companies and their employees from and against all liabilities, losses, claims, costs and expenses (including attorney's fees and expenses) related to any claim, investigation, litigation or proceeding (whether or not Omron is a party) which arises or is alleged to arise from Buyer's acts or omissions under these Terms or in any way with respect to the Products. Without limiting the foregoing, Buyer (at its own expense) shall indemnify and hold harmless Omron and defend or settle any action brought against such Companies to the extent based on a claim that any Product made to Buyer specifications infringed intellectual property rights of another party.
16. **Property; Confidentiality.** Any intellectual property in the Products is the exclusive property of Omron Companies and Buyer shall not attempt to duplicate it in any way without the written permission of Omron. Notwithstanding any charges to Buyer for engineering or tooling, all engineering and tooling shall remain the exclusive property of Omron. All information and materials supplied by Omron to Buyer relating to the Products are confidential and proprietary, and Buyer shall limit distribution thereof to its trusted employees and strictly prevent disclosure to any third party.
17. **Export Controls.** Buyer shall comply with all applicable laws, regulations and licenses regarding (i) export of products or information; (ii) sale of products to "forbidden" or other proscribed persons; and (iii) disclosure to non-citizens of regulated technology or information.
18. **Miscellaneous.** (a) **Waiver.** No failure or delay by Omron in exercising any right and no course of dealing between Buyer and Omron shall operate as a waiver of rights by Omron. (b) **Assignment.** Buyer may not assign its rights hereunder without Omron's written consent. (c) **Law.** These Terms are governed by the law of the jurisdiction of the home office of the Omron company from which Buyer is purchasing the Products (without regard to conflict of law principles). (d) **Amendment.** These Terms constitute the entire agreement between Buyer and Omron relating to the Products, and no provision may be changed or waived unless in writing signed by the parties. (e) **Severability.** If any provision hereof is rendered ineffective or invalid, such provision shall not invalidate any other provision. (f) **Setoff.** Buyer shall have no right to set off any amounts against the amount owing in respect of this invoice. (g) **Definitions.** As used herein, "including" means "including without limitation"; and "Omron Companies" (or similar words) mean Omron Corporation and any direct or indirect subsidiary or affiliate thereof.

Certain Precautions on Specifications and Use

1. **Suitability of Use.** Omron Companies shall not be responsible for conformity with any standards, codes or regulations which apply to the combination of the Product in the Buyer's application or use of the Product. At Buyer's request, Omron will provide applicable third party certification documents identifying ratings and limitations of use which apply to the Product. This information by itself is not sufficient for a complete determination of the suitability of the Product in combination with the end product, machine, system, or other application or use. Buyer shall be solely responsible for determining appropriateness of the particular Product with respect to Buyer's application, product or system. Buyer shall take application responsibility in all cases but the following is a non-exhaustive list of applications for which particular attention must be given: (i) Outdoor use, uses involving potential chemical contamination or electrical interference, or conditions or uses not described in this document. (ii) Use in consumer products or any use in significant quantities. (iii) Energy control systems, combustion systems, railroad systems, aviation systems, medical equipment, amusement machines, vehicles, safety equipment, and installations subject to separate industry or government regulations. (iv) Systems, machines and equipment that could present a risk to life or property. Please know and observe all prohibitions of use applicable to this Product. NEVER USE THE PRODUCT FOR AN APPLICATION INVOLVING SERIOUS RISK TO LIFE OR PROPERTY OR IN LARGE QUANTITIES WITHOUT ENSURING THAT THE SYSTEM AS A WHOLE HAS BEEN DESIGNED TO ADDRESS THE RISKS, AND THAT THE OMRON'S PRODUCT IS PROPERLY RATED AND INSTALLED FOR THE INTENDED USE WITHIN THE OVERALL EQUIPMENT OR SYSTEM.
2. **Programmable Products.** Omron Companies shall not be responsible for the user's programming of a programmable Product, or any consequence thereof.
3. **Performance Data.** Data presented in Omron Company websites, catalogs and other materials is provided as a guide for the user in determining suitability and does not constitute a warranty. It may represent the result of Omron's test conditions, and the user must correlate it to actual application requirements. Actual performance is subject to the Omron's Warranty and Limitations of Liability.
4. **Change in Specifications.** Product specifications and accessories may be changed at any time based on improvements and other reasons. It is our practice to change part numbers when published ratings or features are changed, or when significant construction changes are made. However, some specifications of the Product may be changed without any notice. When in doubt, special part numbers may be assigned to fix or establish key specifications for your application. Please consult with your Omron's representative at any time to confirm actual specifications of purchased Product.
5. **Errors and Omissions.** Information presented by Omron Companies has been checked and is believed to be accurate; however, no responsibility is assumed for clerical, typographical or proofreading errors or omissions.

OMRON AUTOMATION AND SAFETY • THE AMERICAS HEADQUARTERS • Chicago, IL USA • 847.843.7900 • 800.556.6766 • www.omron247.com

OMRON CANADA, INC. • HEAD OFFICE

Toronto, ON, Canada • 416.286.6465 • 866.986.6766 • www.omron247.com

OMRON ELECTRONICS DE MEXICO • HEAD OFFICE

México DF • 52.55.59.01.43.00 • 01-800-226-6766 • mela@omron.com

OMRON ELECTRONICS DE MEXICO • SALES OFFICE

Apodaca, N.L. • 52.81.11.56.99.20 • 01-800-226-6766 • mela@omron.com

OMRON ELETRÔNICA DO BRASIL LTDA • HEAD OFFICE

São Paulo, SP, Brasil • 55.11.2101.6300 • www.omron.com.br

OMRON ARGENTINA • SALES OFFICE

Cono Sur • 54.11.4783.5300

OMRON CHILE • SALES OFFICE

Santiago • 56.9.9917.3920

OTHER OMRON LATIN AMERICA SALES

54.11.4783.5300

OMRON EUROPE B.V. • Wegalaan 67-69, NL-2132 JD, Hoofddorp, The Netherlands. • +31 (0) 23 568 13 00 • www.industrial.omron.eu

Authorized Distributor:

Automation Control Systems

- Machine Automation Controllers (MAC) • Programmable Controllers (PLC)
- Operator interfaces (HMI) • Distributed I/O • Software

Drives & Motion Controls

- Servo & AC Drives • Motion Controllers & Encoders

Temperature & Process Controllers

- Single and Multi-loop Controllers

Sensors & Vision

- Proximity Sensors • Photoelectric Sensors • Fiber-Optic Sensors
- Amplified Photomicrosensors • Measurement Sensors
- Ultrasonic Sensors • Vision Sensors

Industrial Components

- RFID/Code Readers • Relays • Pushbuttons & Indicators
- Limit and Basic Switches • Timers • Counters • Metering Devices
- Power Supplies

Safety

- Laser Scanners • Safety Mats • Edges and Bumpers • Programmable Safety Controllers • Light Curtains • Safety Relays • Safety Interlock Switches

X-ON Electronics

Largest Supplier of Electrical and Electronic Components

Click to view similar products for [Controllers](#) category:

Click to view products by [Omron](#) manufacturer:

Other Similar products are found below :

[61FGPN8DAC120](#) [CV500SLK21](#) [70177-1011](#) [F03-03 HAS C](#) [F03-31](#) [81550401](#) [FT1A-C12RA-W](#) [88981106](#) [H2CAC24A](#) [H2CRSAC110B](#)
[R88A-CRGB003CR-E](#) [R88ARR080100S](#) [R88A-TK01K](#) [DCN1-1](#) [DRT2ID08C](#) [DTB4896VRE](#) [DTB9696CVE](#) [DTB9696LVE](#) [E53-AZ01](#)
[E53E01](#) [E53E8C](#) [E5C4Q40J999FAC120](#) [E5CWLQ1TCAC100240](#) [E5GNQ03PFLKACDC24](#) [B300LKL21](#) [NSCXDC1V3](#) [NSH5-232CW-3M](#)
[NT20SST122BV1](#) [NV-CN001](#) [OAS-160-N](#) [C40PEDRA](#) [K31S6](#) [K33-L1B](#) [K3MA-F](#) [100-240VAC](#) [K3TX-AD31A](#) [89750101](#) [L595020](#)
[SRM1-C02](#) [SRS2-1](#) [FT1A-C14SA-S](#) [G32X-V2K](#) [26546803](#) [26546805](#) [PWRA440A](#) [CPM1AETL03CH](#) [CV500SLK11](#) [3G2A5BI081](#)
[3G2A5IA122](#) [3G2A5LK010E](#) [3G2A5OA223](#)