

Positioning with Pulse Input Type Motor Drivers Such As Stepper Motor Drive

- The MC Function Modules of the NJ/NX/NY5-series Machine Automation Controller enable pulse outputs for motor control.
- The same motion control instructions as those for Servomotor control allow you to program single-axis PTP control and interpolation.
- Non-networked motors, such as DD motors, stepper motors, and DC motors, can be connected.

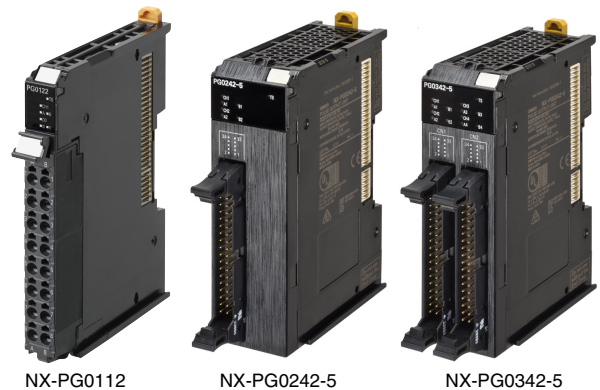

Features

- When the motion control instructions of the MC Function Modules of the NJ/NX/NY5-series Machine Automation Controller are used, number of usable units is the same as the maximum number of axes controlled by the NJ/NX/NY5-series Controller.
- High-speed remote I/O control with communications cycle as fast as 125 μ s.*1
- Synchronous I/O refreshing or Task Period Prioritized refreshing *2, can be selected for refreshing with the NX-series EtherCAT Coupler.
- Latch function (2 external latch inputs)
- Open collector pulse outputs up to 500 kHz or line driver pulse outputs up to 4 MHz.
- Line driver output models with two or four channels.
- Connection to the CJ-series is possible by connecting with the EtherNet/IP™ Coupler.

*1. When using the NX-EC01□□ together with the NX701-□□□□ and NX-ECC203.

*2. Task Period Prioritized refreshing is available when the NX-ECC203 is used together.

System Configuration

Connected to a CPU Unit

The following figure shows a system configuration when a group of NX Units is connected to an NX-series CPU Unit.

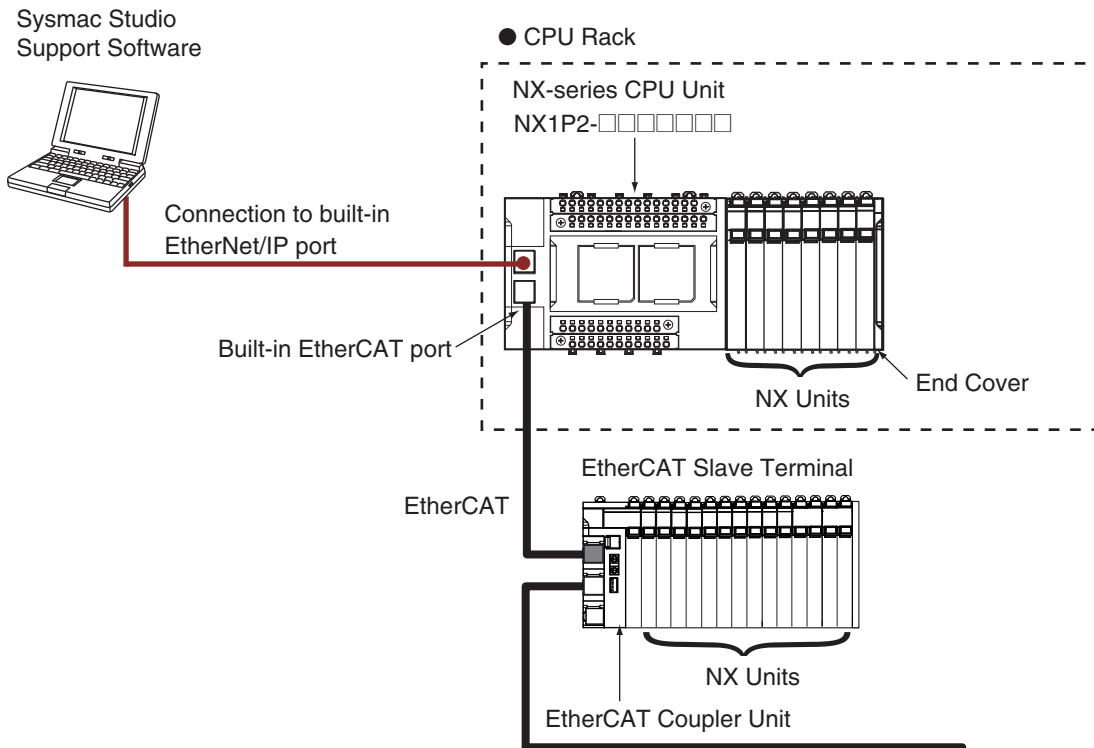

Connected to an EtherCAT Coupler Unit

The following figure shows an example of the system configuration when an EtherCAT Coupler Unit is used as a Communications Coupler Unit.

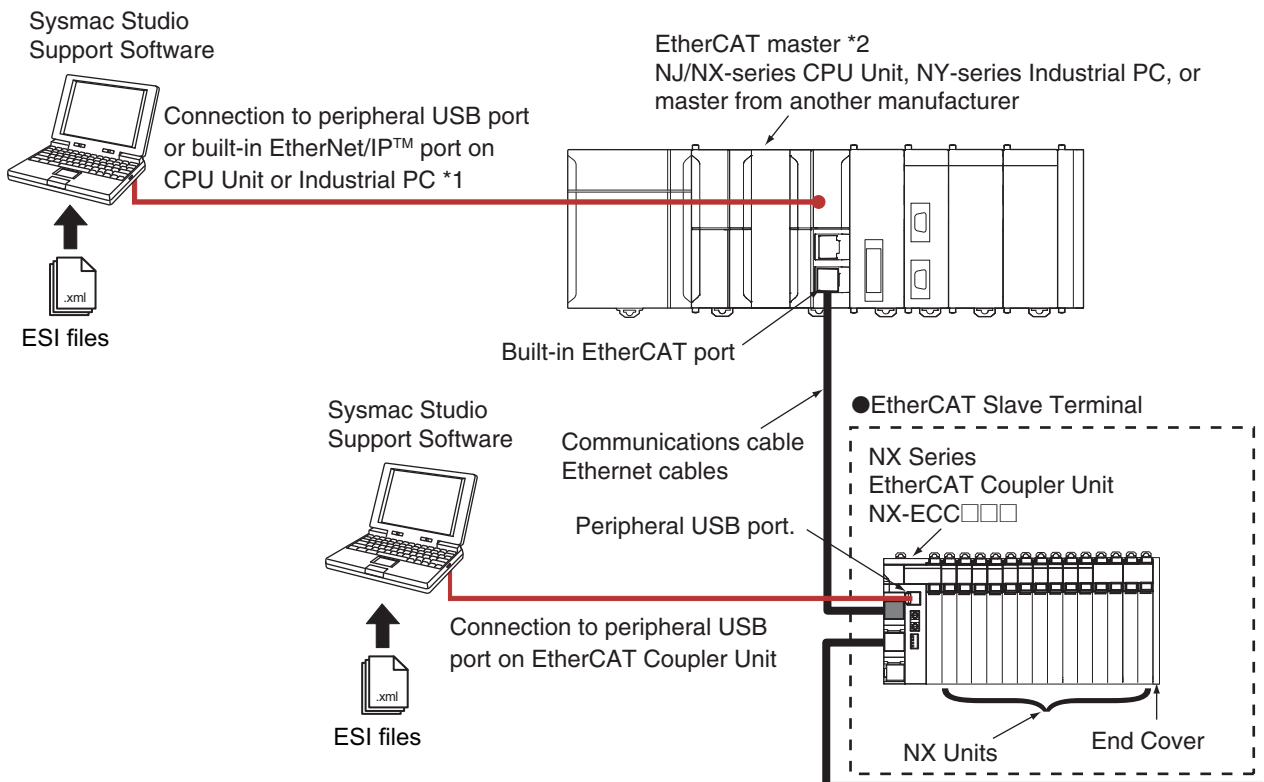

*1. The connection method for the Sysmac Studio depends on the model of the CPU Unit or Industrial PC.

*2. An EtherCAT Slave Terminal cannot be connected to any of the OMRON CJ1W-NC□□81□□82 Position Control Units even though they can operate as EtherCAT masters.

Note: For whether NX Units can be connected to the CPU Unit or Communications Coupler Unit to be used, refer to the user's manual for the CPU Unit or Communications Coupler Unit to be used.

Examples for the system configuration of an Pulse Output Unit

NX-PG0112/-PG0122

The following figure shows the system configuration of NX-PG0112 and NX-PG0122.

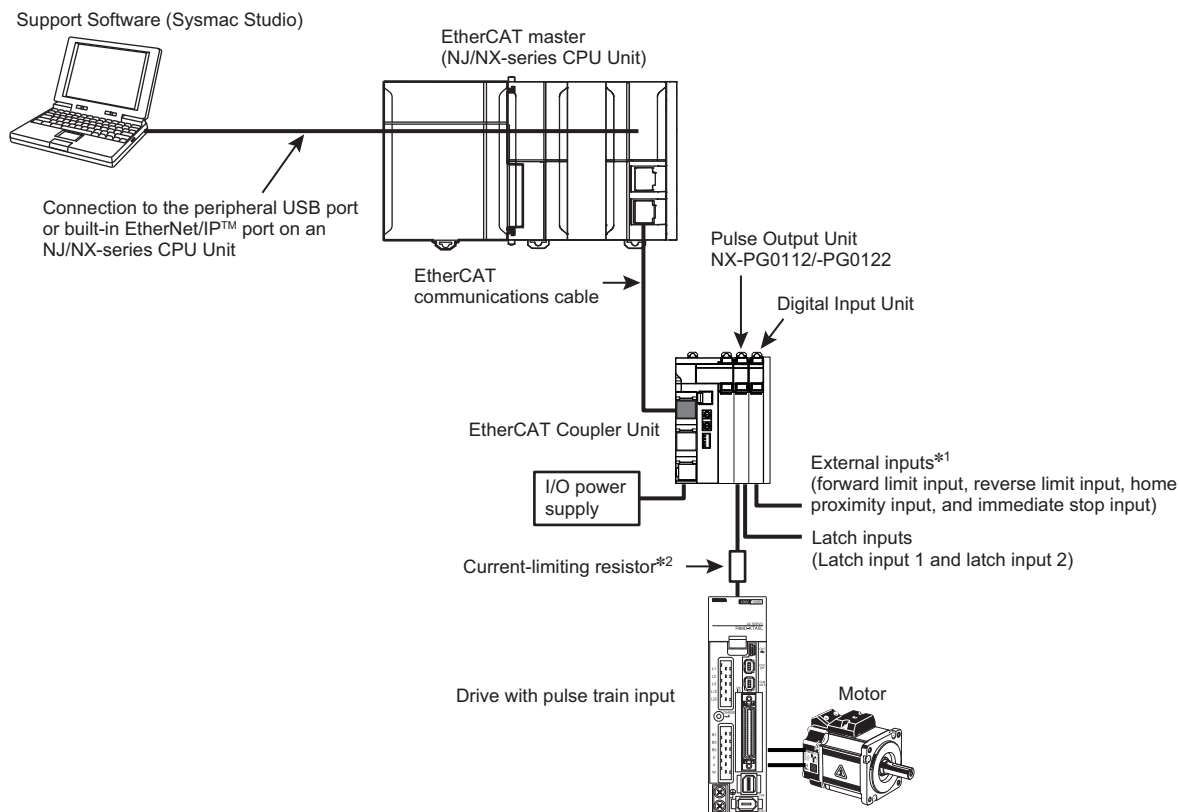

*1. When the Unit is connected to an NJ-series CPU, you can use these inputs by adding a Digital Input Unit and assigning MC Function Module functions.

*2. The pulse output from a Pulse Output Unit is a 24-VDC PNP open collector output. Connect an external current-limiting resistor according to the input specifications of the connected motor drive.

Example: For a G5-series Servo Drive, connect a 2-k Ω (1/2-W) resistor in series.

NX-PG0232-5/-PG0242-5/-PG0332-5/-PG0342-5

The following figure shows the system configuration of NX-PG0232-5, NX-PG0242-5, NX-PG0332-5, and NX-PG0342-5.

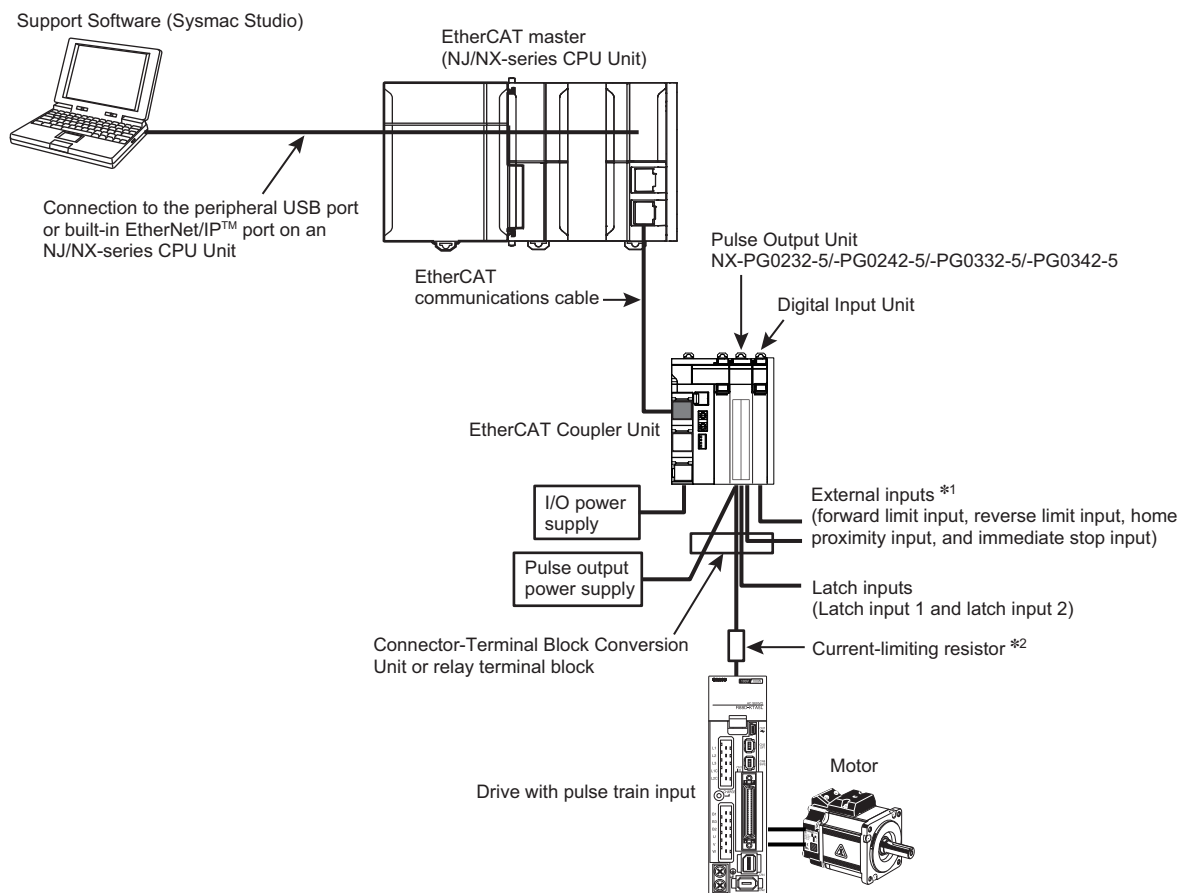

*1. When the Unit is connected to an NJ/NX-series CPU, you can use these inputs by assigning MC Function Module functions to external inputs inside a Pulse Output Unit or to inputs of a Digital Input Unit that is added. For information on Digital Input Units, refer to the *NX-series Digital I/O Units User's Manual* (Cat. No. W521). For NX-PG0232-5, NX-PG0242-5, NX-PG0332-5, and NX-PG0342-5 Pulse Output Units, the number of available external inputs that can be used in always ON status is restricted by ambient operating temperature and installation orientation.

*2. The pulse output from a Pulse Output Unit is a 24-VDC open collector output. When it is used as a control output for a motor drive such as an error counter reset output, connect an external current-limiting resistor according to the input specifications of the connected motor drive. A line drive output does not need a current limiting resistor.

Ordering Information

International Standards

- The standards are abbreviated as follows: U: UL, U1: UL(Class I Division 2 Products for Hazardous Locations), C: CSA, UC: cULus, UC1: cULus (Class I Division 2 Products for Hazardous Locations), CU: cUL, N: NK, L: Lloyd, CE: EU Directives, RCM: RCM mark, and KC: KC Registration.
- Contact your OMRON representative for further details and applicable conditions for these standards.







Pulse Output Units

Unit type	Product name	Specification							Model	Standards
		Number of channels *1	External inputs	External outputs	Maximum pulse output speed	I/O refreshing method	Number of I/O entry mappings	Control output interface		
NX-series Position Interface Unit		1 (NPN)	2 (NPN)	1 (NPN)	500 kpps	<ul style="list-style-type: none"> Synchronous I/O refreshing Task period prioritized refreshing *2 	1/1	Open collector output	NX-PG0112	UC1, N, CE, RCM, KC
		1 (PNP)	2 (PNP)	1 (PNP)					NX-PG0122	
		2	5 inputs/CH (NPN)	3 outputs/CH (NPN)	4 Mpps		2/2	Line driver output	NX-PG0232-5	UC1, CE, RCM, KC
			5 inputs/CH (PNP)	3 outputs/CH (PNP)					NX-PG0242-5	
		4	5 inputs/CH (NPN)	3 outputs/CH (NPN)			NX-PG0332-5			
			5 inputs/CH (PNP)	3 outputs/CH (PNP)			NX-PG0342-5			

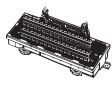
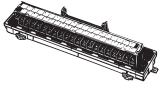
*1. This is the number of pulse output channels.

*2. Unit version 1.2 or later and an NX-ECC203 EtherCAT Coupler Unit are required.

Cables and Connectors for Line Driver Output Units with MIL Connectors

Product name	Specifications		Model	Standards
Connector-Terminal Block Conversion Unit	Flat Cable Connectors type (Terminal block with M3 screws) 34-terminals		XW2B-34G4	---
	Flat Cable Connectors type (Terminal block with M3.5 screws) 34-terminals		XW2B-34G5	---
	MIL Connectors type (Slim Connector) 34-terminals		XW2D-34G6	---
	MIL Connectors type (Phillips screw) 34-terminals		XW2R-J34GD-T	---
	MIL Connectors type (Slotted screw (rise up)) 34-terminals		XW2R-E34GD-T	---
	MIL Connectors type (Push-in spring) 34-terminals		XW2R-P34GD-T	---
Cable for Connector-Terminal Block Conversion Unit	MIL Connectors type 34-terminals 	Cable length: 0.5 m	XW2Z-050EE	---
		Cable length: 1 m	XW2Z-100EE	
		Cable length: 1.5 m	XW2Z-150EE	
		Cable length: 2 m	XW2Z-200EE	
		Cable length: 3 m	XW2Z-300EE	
		Cable length: 5 m	XW2Z-500EE	

Note: Each of NX-PG0232-5 and NX-PG0242-5 has one MIL connector. Therefore, one Connector-Terminal Block Conversion Unit is required. Each of NX-PG0332-5 and NX-PG0342-5 has two MIL connectors. Therefore, two Connector-Terminal Block Conversion Units are required.

Option

Product name	Specification				Model	Standards
Unit/Terminal Block Coding Pins	For 10 Units (Terminal Block: 30 pins, Unit: 30 pins)				NX-AUX02	–

Product name	Specification				Model	Standards
	No. of terminals	Terminal number indications	Ground terminal mark	Terminal current capacity		
Terminal Block	16	A/B	None	10 A	NX-TBA162	–

Accessories

Not included.

General Specification

Item		Specification
Enclosure		Mounted in a panel
Grounding method		Ground to less than 100 Ω or less
Operating environment	Ambient operating temperature	0 to 55°C
	Ambient operating humidity	10% to 95% (with no condensation or icing)
	Atmosphere	Must be free from corrosive gases.
	Ambient storage temperature	-25 to 70°C (with no condensation or icing)
	Altitude	2,000 m max.
	Pollution degree	Pollution degree 2 or less: Conforms to JIS B3502 and IEC 61131-2.
	Noise immunity	Conforms to IEC61000-4-4, 2 kV (power supply line)
	Overvoltage category	Category II: Conforms to JIS B3502 and IEC 61131-2.
	EMC immunity level	Zone B
	Vibration resistance	Conforms to IEC 60068-2-6. 5 to 8.4 Hz with 3.5-mm amplitude, 8.4 to 150 Hz, acceleration of 9.8 m/s ² , 100 min each in X, Y, and Z directions (10 sweeps of 10 min each = 100 min total)
Shock resistance	Conforms to IEC 60068-2-27. 147 m/s ² , 3 times each in X, Y, and Z directions	
Applicable standards *		cULus: Listed (UL508 or UL61010-2-201), ANSI/ISA 12.12.01, EU: EN 61131-2, C-Tick or RCM, KC (KC Registration), NK, and LR

* Refer to the OMRON Industrial Automation website (<http://www.ia.omron.com/>) or consult your OMRON representative for the most recent applicable standards for each model.

Specification

Pulse Output Units (Open collector output, NPN type) NX-PG0112

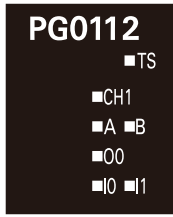
Unit name	Pulse Output Units		Model	NX-PG0112
Number of axes	1	Type of external connections	Screwless clamping terminal block (16 terminals)	
I/O refreshing method *1	Synchronous I/O refreshing or task period prioritized refreshing			
Indicators			I/O signals	Inputs: 2, External inputs Outputs: 3, The outputs are the forward direction pulse output, reverse direction pulse output, and external output (one of each output).
Control method	Open-loop control through pulse string output			
Controlled drive	Servo drive with a pulse string input or a stepper motor drive			
Pulse output form	Open collector output			
Unit of control	Pulses			
Maximum pulse output speed	500 kpps			
Pulse output method	Forward/reverse direction outputs or Pulse + direction outputs			
Position control range	-2,147,483,648 to 2,147,483,647 pulses			
Velocity control range	1 to 500,000 pps			
Positioning *2				
Single-axis position control	Absolute positioning, relative positioning, and interrupt feeding			
Single-axis velocity control	Velocity control (velocity feeding in Position Control Mode)			
Single-axis synchronized control	Cam operation and gear operation			
Single-axis manual operation	Jogging			
Auxiliary function for single-axis control	Homing, stopping, and override changes			
External input specifications				
Input voltage	20.4 to 28.8 VDC (24 VDC +20%/–15%)	ON voltage/ON current	15 VDC min./3 mA min.	
Input current	4.6 mA typical (24 VDC)	OFF voltage/OFF current	4.0 VDC max./1 mA max.	
ON/OFF response time	1 μs max./2 μs max.			
Internal I/O common processing	NPN			
Pulse output and external output specifications				
Rated voltage	24 VDC			
Load voltage range	15 to 28.8 VDC	Residual voltage	1.0 V max.	
Maximum load current	30 mA	Leakage current	0.1 mA max.	
ON/OFF response time	Pulse output: Refer to "NX-series Position Interface Units User's Manual (W524-E1)". External output: 5 μs max./5 μs max.			
Internal I/O common processing	NPN			
Dimensions	12 × 100 × 71 mm (W×H×D)	Isolation method	External inputs: Photocoupler isolation External outputs: Digital isolator	
Insulation resistance	20 MΩ min. between isolated circuits (at 100 VDC)	Dielectric strength	510 VAC between isolated circuits for 1 minute with leakage current of 5 mA max.	
I/O power supply method	Supplied from the NX bus. 20.4 to 28.8 VDC (24 VDC +20%, –15%)	Current capacity of I/O power supply terminals	IOV: 0.1 A max. per terminal IOG: 0.1 A max. per terminal	
NX Unit power consumption	<ul style="list-style-type: none"> Connected to a CPU Unit 1.15 W max. Connected to a Communications Coupler Unit 0.80 W max. 	Current consumption from I/O power supply	20 mA max.	
Weight	70 g max.	Cable length	3 m max.	

*1. The I/O refreshing method is automatically set according to the connected Communications Coupler Unit and CPU Unit.

*2. These functions are supported when you also use the MC Function Module in the NJ/NX-series CPU Unit or the NY-series Industrial PC. For details, refer to the motion control user's manual for the connected CPU Unit or Industrial PC.

A Pulse Output Unit only outputs pulses during the control period based on commands received at a fixed period.

Target position calculations (distribution calculations) for acceleration/deceleration control or for each control period must be performed on the Controller.

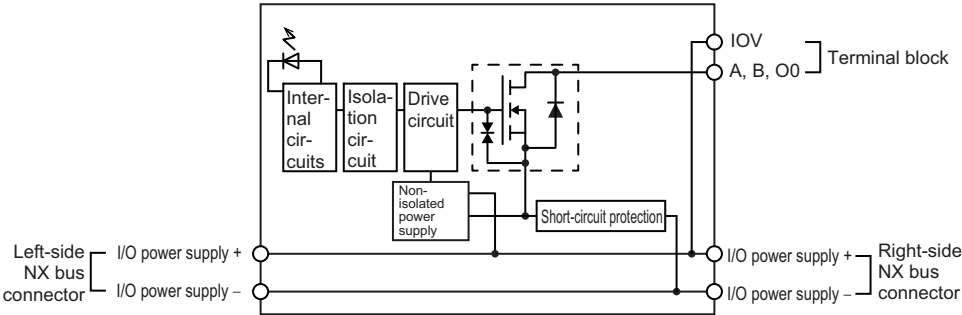
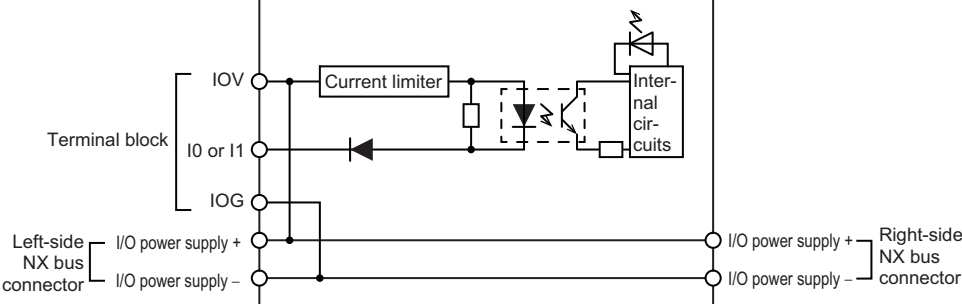
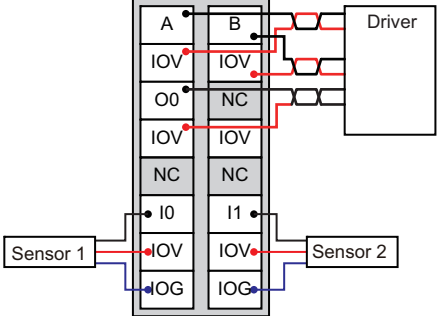
<p>Circuit layout</p>	<p>Pulse Output and External Output</p>  <p>External Inputs</p> 
<p>Installation orientation and restrictions</p>	<p>Installation orientation:</p> <ul style="list-style-type: none"> • Connected to a CPU Unit: Possible in upright installation. • Connected to a Communications Coupler Unit: Possible in 6 orientations. <p>Restrictions: There are no restrictions.</p>
<p>Terminal connection diagram</p>	
<p>Failure detection</p>	<p>None</p> <p style="text-align: center;">Protection</p> <p>None</p>

Pulse Output Units (Open collector output, NPN type) NX-PG0122

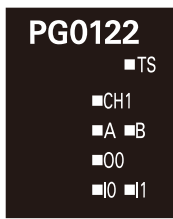
Unit name	Pulse Output Units		Model	NX-PG0122
Number of axes	1	Type of external connections	Screwless push-in terminal block (16 terminals)	
I/O refreshing method *1	Synchronous I/O refreshing or task period prioritized refreshing			
Indicators			I/O signals	Inputs: 2, External inputs *2 Outputs: 3, The outputs are the forward direction pulse output, reverse direction pulse output, and external output *3 (one of each output).
Control method	Open-loop control through pulse string output			
Controlled drive	Servo drive with a pulse train input or a stepper motor drive			
Pulse output form	Open collector output			
Control unit	Pulses			
Maximum pulse output speed	500 kpps			
Pulse output method	Forward/reverse direction pulse outputs or pulse + direction outputs			
Position control range	-2,147,483,648 to 2,147,483,647 pulses			
Velocity control range	1 to 500,000 pps			
Positioning *4				
Single-axis position control	Absolute positioning, relative positioning, and interrupt feeding			
Single-axis velocity control	Velocity control (velocity feeding in Position Control Mode)			
Single-axis synchronized control	Cam operation and gear operation			
Single-axis manual operation	Jogging			
Auxiliary function for single-axis control	Homing, stopping, and override changes			
External input specifications				
Input voltage	20.4 to 28.8 VDC (24 VDC +20%/–15%)	ON voltage/ON current	15 VDC min./3 mA min.	
Input current	4.6 mA typical (24 VDC)	OFF voltage/OFF current	4.0 VDC max./1 mA max.	
ON/OFF response time	1 μs max./2 μs max.			
Internal I/O common processing	PNP			
External output specifications				
Rated voltage	24 VDC		Residual voltage	1.0 V max.
Load voltage range	15 to 28.8 VDC	Leakage current	0.1 mA max.	
Maximum load current	30 mA		ON/OFF response time	
ON/OFF response time	Pulse output: Refer to "NX-series Position Interface Units User's Manual (W524-E1)". 5 μs max./5 μs max.			
Internal I/O common processing	PNP			
Dimensions	12 × 100 × 71 mm (W×H×D)	Isolation method	External inputs: Photocoupler isolation External outputs: Digital isolator	
Insulation resistance	20 MΩ min. between isolated circuits (at 100 VDC)	Dielectric strength	510 VAC between isolated circuits for 1 minute with leakage current of 5 mA max.	
I/O power supply source	Supplied from the NX bus. 20.4 to 28.8 VDC (24 VDC +20%/–15%)	Current capacity of I/O power supply terminals	IOV: 0.1 A max. per terminal IOG: 0.1 A max. per terminal	

*1. The I/O refreshing method is automatically set according to the connected CPU Unit or Communications Coupler Unit.

*2. You can use the external inputs as latch inputs.

*3. You can use the external output as error counter reset outputs.

*4. These functions are supported when you also use the MC Function Module in the NJ/NX-series CPU Unit or the NY-series Industrial PC. For details, refer to the motion control user's manual for the connected CPU Unit or Industrial PC.

A Pulse Output Unit only outputs pulses during the control period based on commands received at a fixed period.

Target position calculations (distribution calculations) for acceleration/deceleration control or for each control period must be performed on the Controller.

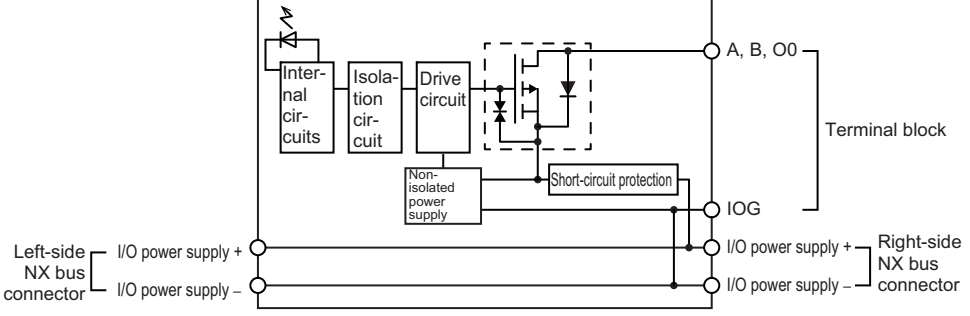
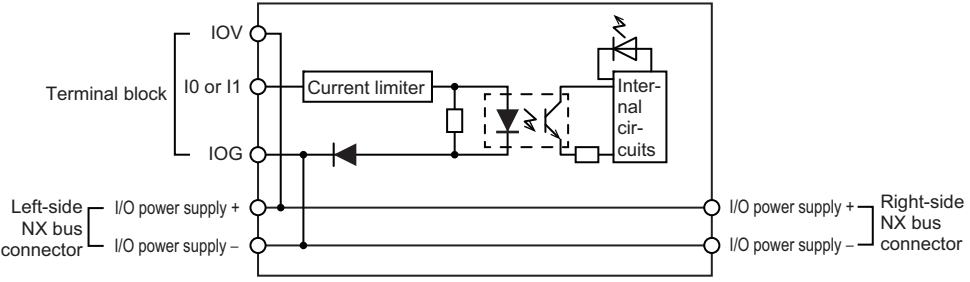
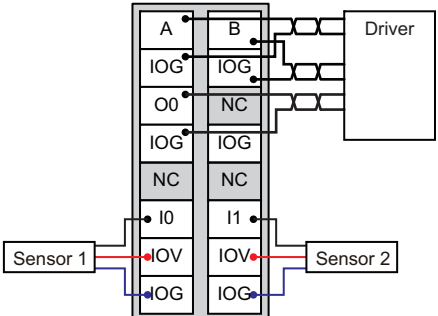
<p>NX Unit power consumption</p>	<ul style="list-style-type: none"> • Connected to a CPU Unit 1.30 W max. • Connected to a Communications Coupler Unit 0.90 W max. 	<p>Current consumption from I/O power supply</p>	<p>20 mA max.</p>
<p>Weight</p>	<p>70 g max.</p>	<p>Cable length</p>	<p>3 m max.</p>
<p>Circuit layout</p>	<p>Pulse Output and External Output</p>  <p>External Inputs</p> 		
<p>Installation orientation and restrictions</p>	<p>Installation orientation:</p> <ul style="list-style-type: none"> • Connected to a CPU Unit: Possible in upright installation. • Connected to a Communications Coupler Unit: Possible in 6 orientations. <p>Restrictions: There are no restrictions.</p>		
<p>Terminal connection diagram</p>			
<p>Failure detection</p>	<p>None</p>	<p>Protection</p>	<p>None</p>

Pulse Output Units (Line driver output, NPN type) 2 channels NX-PG0232-5

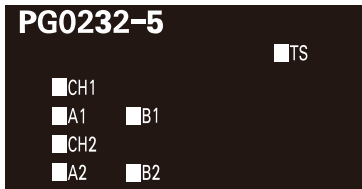
Unit name	Pulse Output Units		Model	NX-PG0232-5
Number of channels	2 channels		Type of external connections	MIL connector (34 terminals x1)
I/O refreshing method *1	Synchronous I/O refreshing or task period prioritized refreshing			
Indicators			I/O signals	Inputs: 5 per channel. External inputs *2 Outputs: 5 per channel. 1 forward direction pulse output, 1 reverse direction pulse output, and 3 external outputs (per channel) *3
Control method	Open-loop control through pulse string output			
Controlled drive	Servo drive with a pulse string input or a stepper motor drive			
Pulse output form	Line driver output			
Unit of control	Pulses			
Maximum pulse output speed	4 Mpps			
Pulse output method	Forward/reverse direction pulse outputs, Pulse + direction outputs, or Phase differential pulse output multiplication x1/2/4			
Position control range	-2,147,483,648 to 2,147,483,647 pulses			
Velocity control range	1 to 4,000,000 pps			
Positioning *4				
Single-axis position control	Absolute positioning, relative positioning, and interrupt feeding			
Single-axis velocity control	Velocity control (velocity feeding in Position Control Mode)			
Single-axis synchronized control	Cam operation and gear operation			
Single-axis manual operation	Jogging			
Auxiliary function for single-axis control	Homing, stopping, and override changes			
External input specifications (except for line receiver inputs)				
Input voltage	21.6 to 26.4 VDC (24 VDC +10%, -10%)	ON voltage/ON current	15 VDC min./3 mA min.	
Input current	4.6 mA typical (24 VDC)	OFF voltage/OFF current	4.0 VDC max./1 mA max.	
ON/OFF response time	External inputs 0 and 1: 1 μs max./2 μs max. External inputs 2 to 4: 20 μs max./400 μs max.			
Internal I/O common processing	NPN			
External input specifications (line receiver inputs)				
Input voltage	EIA standard RS-422-A line driver levels	High level input voltage	VIT+: 0.1 V min.	
Input impedance	120 Ω ± 5%	Low level input voltage	VIT-: -0.1 V max.	
Hysteresis voltage	V _{hys} (VIT+ - VIT-): 60 mV			
Line driver output specifications				
Output voltage	RS-422-A line driver level (equivalent to AM26C31)			
Maximum load current	20 mA			
Maximum output frequency	4 Mpps			
External output specifications				
Rated voltage	24 VDC			
Load voltage range	15 to 28.8 VDC	Residual voltage	1.0 V max.	
Maximum load current	30 mA	Leakage current	0.1 mA max.	
ON/OFF response time	External output 0: 5 μs max./5 μs max. External outputs 1 and 2: 0.5 ms max./1 ms max.			
Internal I/O common processing	NPN			

*1. The I/O refreshing method is automatically set according to the connected Communications Coupler Unit and CPU Unit.

*2. You can use the external input 0 as a latch input.

*3. You can use the external output 0 as an error counter reset output.

*4. These functions are supported when you also use the MC Function Module in the NJ/NX-series CPU Unit or the NY-series Industrial PC. For details, refer to the motion control user's manual for the connected CPU Unit or Industrial PC.

A Pulse Output Unit only outputs pulses during the control period based on commands received at a fixed period.

Target position calculations (distribution calculations) for acceleration/deceleration control or for each control period must be performed on the Controller.

Dimensions	30 × 100 × 71 mm (W×H×D)	Isolation method	External inputs: Photocoupler isolation External outputs: Digital isolator
Insulation resistance	20 MΩ min. between isolated circuits (at 100 VDC)	Dielectric strength	510 VAC between isolated circuits for 1 minute at a leakage current of 5 mA max.
I/O power supply method	Supply from external source 20.4 to 28.8 VDC (24 VDC +20%, -15%)	Current capacity of I/O power supply terminals	Without I/O power supply terminals
NX Unit power consumption	<ul style="list-style-type: none"> Connected to a CPU Unit 1.55 W max. Connected to a Communications Coupler Unit 1.20 W max. 	Current consumption from I/O power supply	50 mA max.
Weight	110 g max.	Cable length	Line driver outputs: 10 m max. Other I/O: 3 m max.

Circuit layout

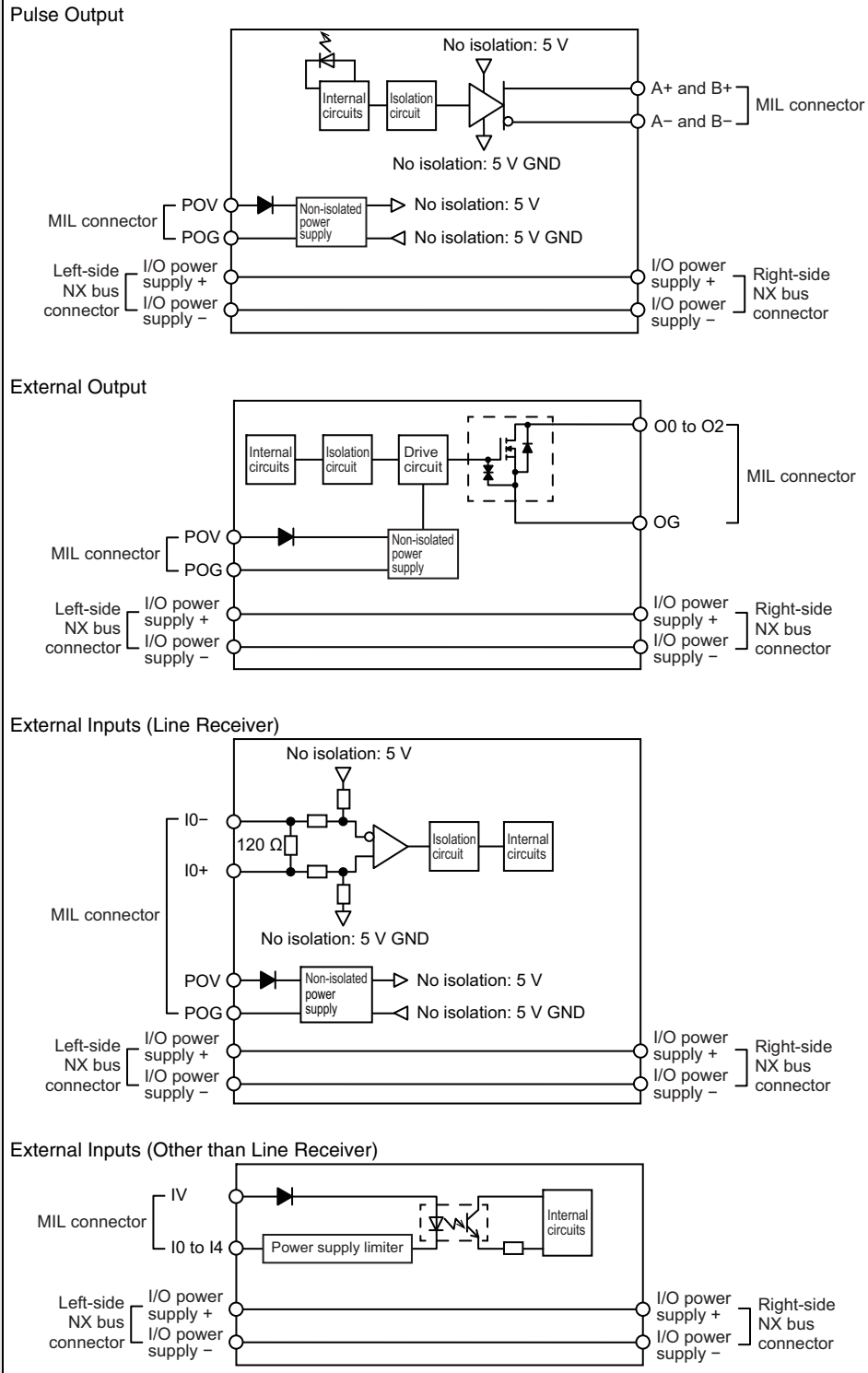

Installation orientation and restrictions

Installation orientation:

- Connected to a CPU Unit: Possible in upright installation.
- Connected to a Communications Coupler Unit: Possible in 6 orientations.

Restrictions: The number of external inputs that can be always ON is restricted as shown below.

- For upright installation

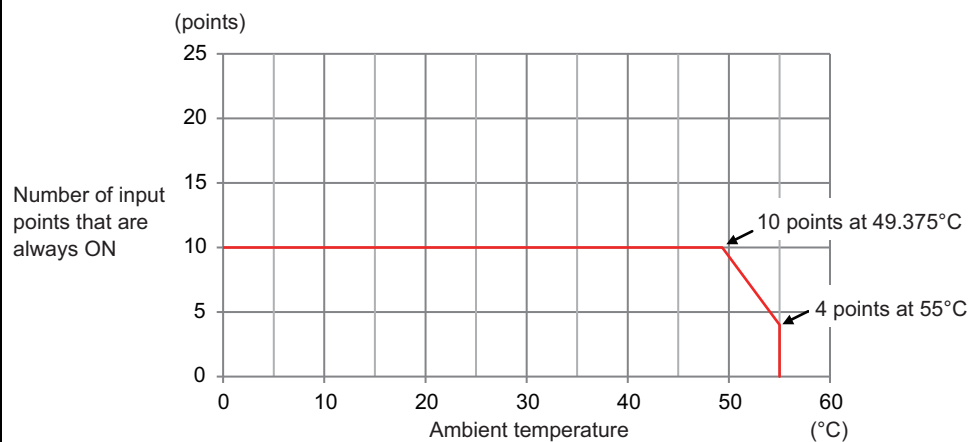

- For any installation other than upright

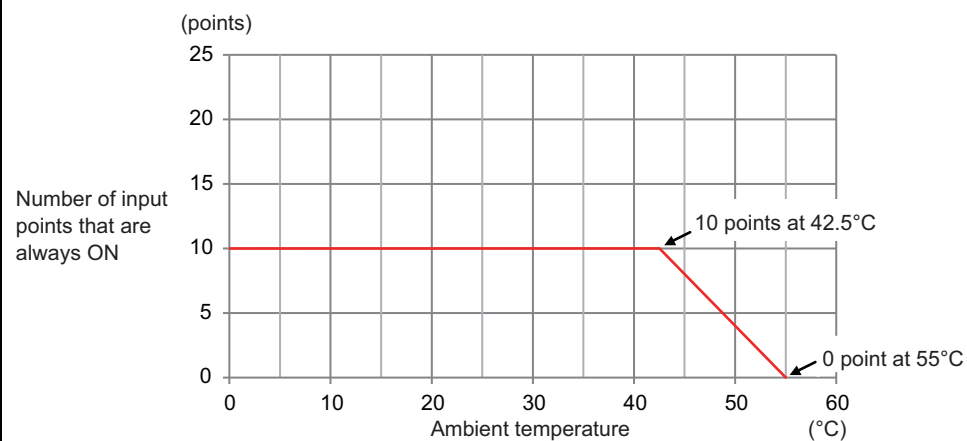

Terminal connection diagram

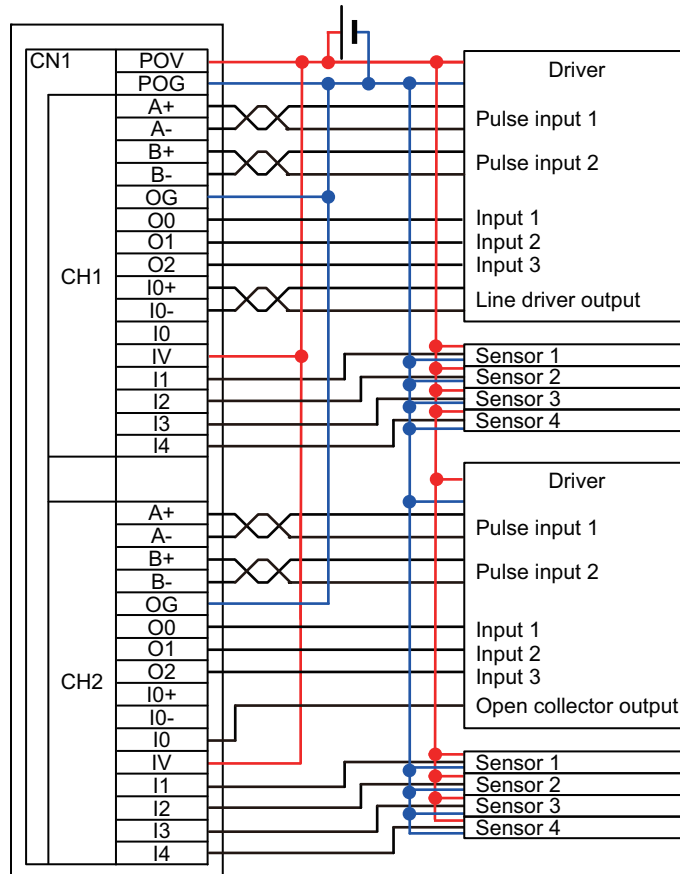

Failure detection	None	Protection	None
--------------------------	------	-------------------	------

Pulse Output Units (Line driver output, PNP type) 2 channels NX-PG0242-5

Unit name	Pulse Output Units		Model	NX-PG0242-5
Number of channels	2 channels		Type of external connections	MIL connector (34 terminals x1)
I/O refreshing method *1	Synchronous I/O refreshing or task period prioritized refreshing			
Indicators			I/O signals	Inputs: 5 per channel. External inputs *2 Outputs: 5 per channel. 1 forward direction pulse output, 1 reverse direction pulse output, and 3 external outputs (per channel) *3
Control method	Open-loop control through pulse string output			
Controlled drive	Servo drive with a pulse string input or a stepper motor drive			
Pulse output form	Line driver output			
Unit of control	Pulses			
Maximum pulse output speed	4 Mpps			
Pulse output method	Forward/reverse direction pulse outputs, Phase + direction outputs, or Phase differential pulse output multiplication x1/2/4			
Position control range	-2,147,483,648 to 2,147,483,647 pulses			
Velocity control range	1 to 4,000,000 pps			
Positioning*4				
Single-axis position control	Absolute positioning, relative positioning, and interrupt feeding			
Single-axis velocity control	Velocity control (velocity feeding in Position Control Mode)			
Single-axis synchronized control	Cam operation and gear operation			
Single-axis manual operation	Jogging			
Auxiliary function for single-axis control	Homing, stopping, and override changes			
External input specifications (except for line receiver inputs)				
Input voltage	21.6 to 26.4 VDC (24 VDC +10%, -10%)	ON voltage/ON current	15 VDC min./3 mA min.	
Input current	4.6 mA typical (24 VDC)	OFF voltage/OFF current	4.0 VDC max./1 mA max.	
ON/OFF response time	External inputs 0 and 1: 1 μs max./2 μs max. External inputs 2 to 4: 20 μs max./400 μs max.			
Internal I/O common processing	PNP			
External input specifications (line receiver inputs)				
Input voltage	EIA standard RS-422-A line driver levels	High level input voltage	VIT+: 0.1 V min.	
Input impedance	120 Ω ± 5%	Low level input voltage	VIT-: -0.1 V max.	
Hysteresis voltage	V _{hys} (VIT+ - VIT-): 60 mV			
Line driver output specifications				
Output voltage	RS-422-A line driver level (equivalent to AM26C31)			
Maximum load current	20 mA			
Maximum output frequency	4 Mpps			
External output specifications				
Rated voltage	24 VDC			
Load voltage range	15 to 28.8 VDC	Residual voltage	1.0 V max.	
Maximum load current	30 mA	Leakage current	0.1 mA max.	
ON/OFF response time	External output 0: 5 μs max./200 μs max. External outputs 1 and 2: 0.5 ms max./1 ms max.			
Internal I/O common processing	PNP			

*1. The I/O refreshing method is set according to the connected Communications Coupler Unit and CPU Unit.

*2. You can use the external input 0 as a latch input.

*3. You can use the external output 0 as an error counter reset output.

*4. These functions are supported when you also use the MC Function Module in the NJ/NX-series CPU Unit or the NY-series Industrial PC. For details, refer to the motion control user's manual for the connected CPU Unit or Industrial PC.

A Pulse Output Unit only outputs pulses during the control period based on commands received at a fixed period.

Target position calculations (distribution calculations) for acceleration/deceleration control or for each control period must be performed on the Controller.

Dimensions	30 × 100 × 71 mm (W×H×D)	Isolation method	External inputs: Photocoupler isolation External outputs: Digital isolator
Insulation resistance	20 MΩ min. between isolated circuits (at 100 VDC)	Dielectric strength	510 VAC between isolated circuits for 1 minute at a leakage current of 5 mA max.
I/O power supply method	Supply from external source 20.4 to 28.8 VDC (24 VDC +20%, -15%)	Current capacity of I/O power supply terminals	Without I/O power supply terminals
NX Unit power consumption	<ul style="list-style-type: none"> Connected to a CPU Unit 1.55 W max. Connected to a Communications Coupler Unit 1.20 W max. 	Current consumption from I/O power supply	50 mA max.
Weight	110 g max.	Cable length	Line driver outputs: 10 m max. Other I/O: 3 m max.

Circuit layout

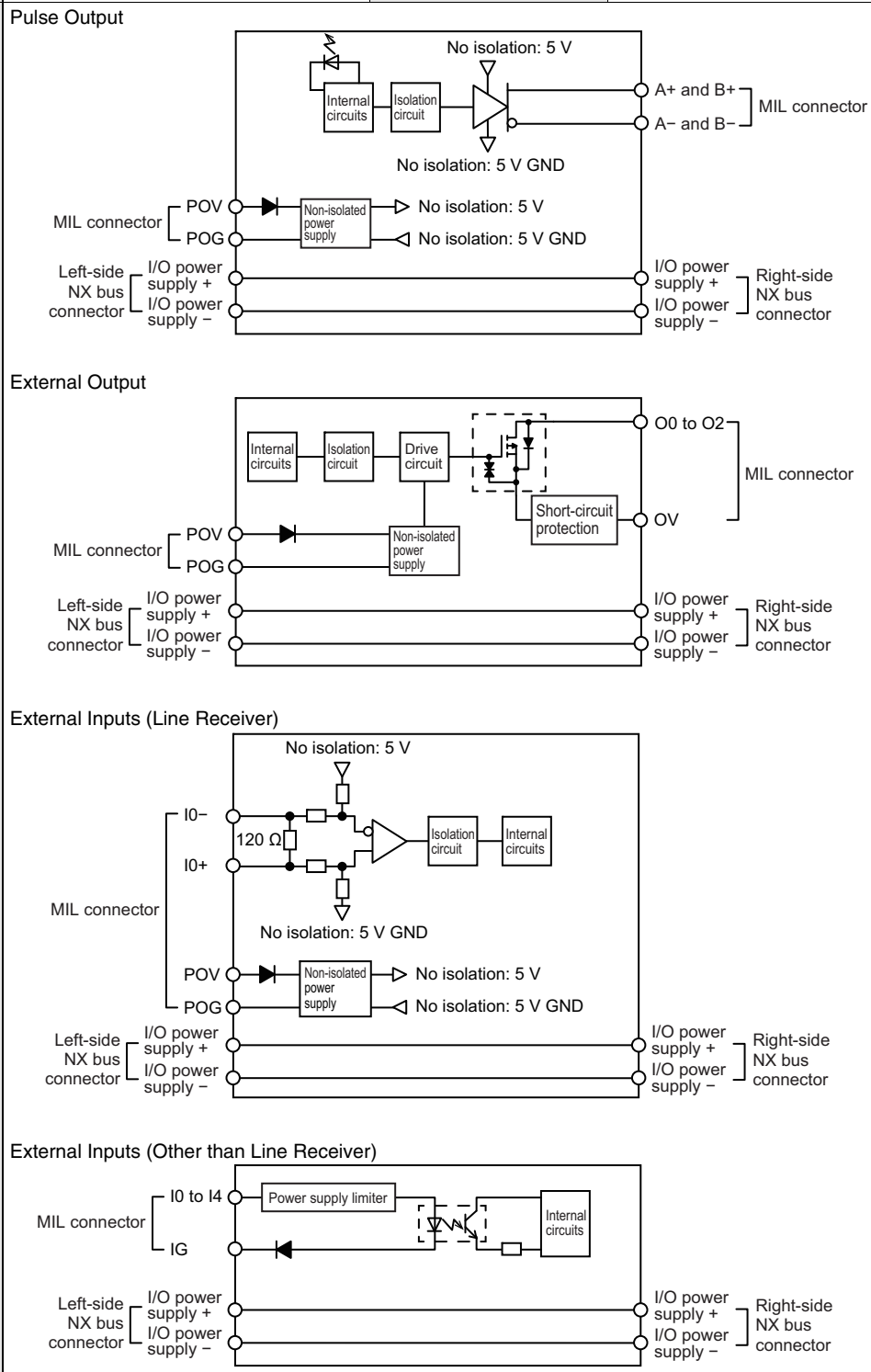

Installation orientation and restrictions

Installation orientation:

- Connected to a CPU Unit: Possible in upright installation.
- Connected to a Communications Coupler Unit: Possible in 6 orientations.

Restrictions: The number of external inputs that can be always ON is restricted as shown below.

- For upright installation

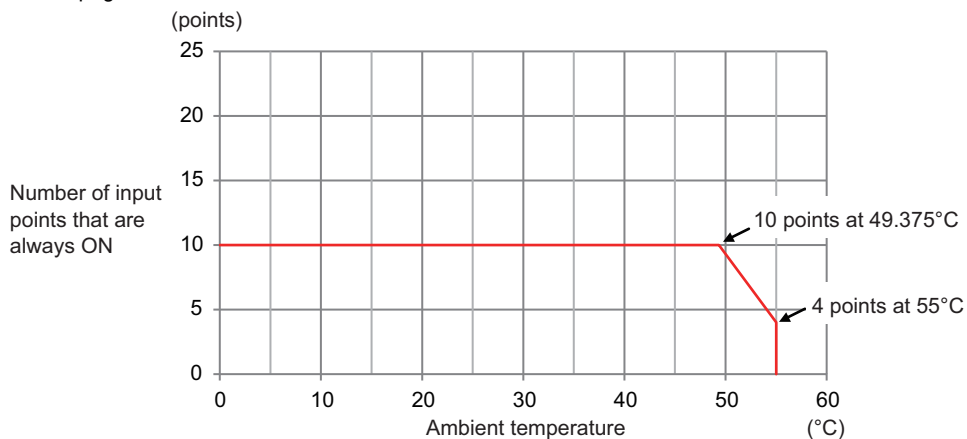

- For any installation other than upright

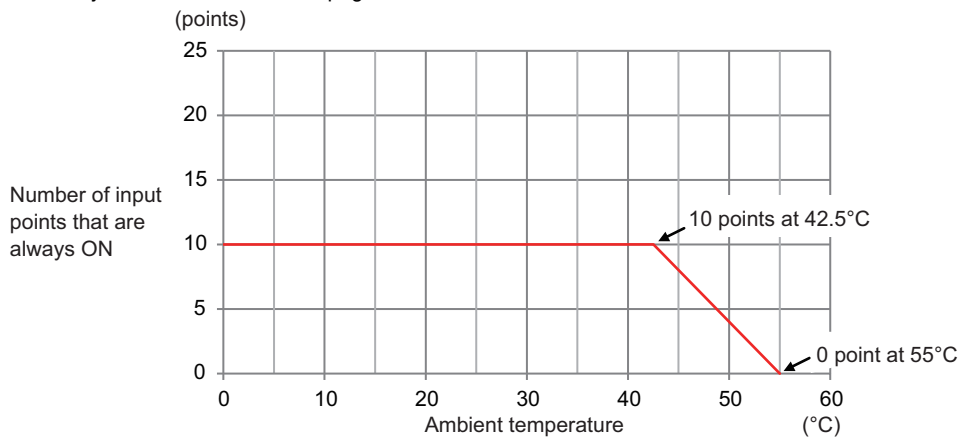

Terminal connection diagram

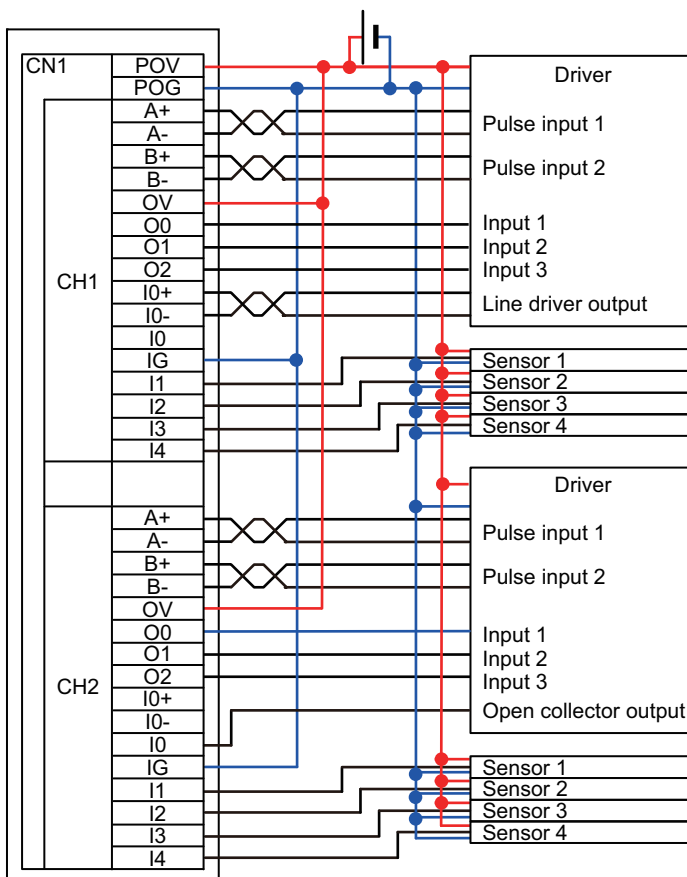

Failure detection

None

Protection

None

Pulse Output Units (Line driver output, NPN type) 4 channels NX-PG0332-5

Unit name	Pulse Output Units		Model	NX-PG0332-5
Number of channels	4 channels		Type of external connections	MIL connector (34 terminals x2)
I/O refreshing method *1	Synchronous I/O refreshing or task period prioritized refreshing			
Indicators			I/O signals	Inputs: 5 per channel. External inputs*2 Outputs: 5 per channel. 1 forward direction pulse output, 1 reverse direction pulse output, and 3 external outputs (per channel)*3
Control method	Open-loop control through pulse string output			
Controlled drive	Servo drive with a pulse string input or a stepper motor drive			
Pulse output form	Line driver output			
Unit of control	Pulses			
Maximum pulse output speed	4 Mpps			
Pulse output method	Forward/reverse direction pulse outputs, Pulse + direction outputs, or Phase differential pulse output multiplication x1/2/4			
Position control range	-2,147,483,648 to 2,147,483,647 pulses			
Velocity control range	1 to 4,000,000 pps			
Positioning *4				
Single-axis position control	Absolute positioning, relative positioning, and interrupt feeding			
Single-axis velocity control	Velocity control (velocity feeding in Position Control Mode)			
Single-axis synchronized control	Cam operation and gear operation			
Single-axis manual operation	Jogging			
Auxiliary function for single-axis control	Homing, stopping, and override changes			
External input specifications (except for line receiver inputs)				
Input voltage	21.6 to 26.4 VDC (24 VDC +10%, -10%)	ON voltage/ON current	15 VDC min./3 mA min.	
Input current	4.6 mA typical (24 VDC)	OFF voltage/OFF current	4.0 VDC max./1 mA max.	
ON/OFF response time	External inputs 0 and 1: 1 μs max./2 μs max. External inputs 2 to 4: 20 μs max./400 μs max.			
Internal I/O common processing	NPN			
External input specifications (line receiver inputs)				
Input voltage	EIA standard RS-422-A line driver levels	High level input voltage	VIT+: 0.1 V min.	
Input impedance	120 Ω ± 5%	Low level input voltage	VIT-: -0.1 V max.	
Hysteresis voltage	V _{hys} (VIT+ - VIT-): 60 mV			
Line driver output specifications				
Output voltage	RS-422-A line driver level (equivalent to AM26C31)			
Maximum load current	20 mA			
Maximum output frequency	4 Mpps			
External output specifications				
Rated voltage	24 VDC			
Load voltage range	15 to 28.8 VDC	Residual voltage	1.0 V max.	
Maximum load current	30 mA	Leakage current	0.1 mA max.	
ON/OFF response time	External output 0: 5 μs max./5 μs max. External outputs 1 and 2: 0.5 ms max./1 ms max.			
Internal I/O common processing	NPN			

*1. The I/O refreshing method is set according to the connected Communications Coupler Unit and CPU Unit.

*2. You can use the external input 0 as a latch input.

*3. You can use the external output 0 as an error counter reset output.

*4. These functions are supported when you also use the MC Function Module in the NJ/NX-series CPU Unit or the NY-series Industrial PC.

For details, refer to the motion control user's manual for the connected CPU Unit or Industrial PC.

A Pulse Output Unit only outputs pulses during the control period based on commands received at a fixed period.

Target position calculations (distribution calculations) for acceleration/deceleration control or for each control period must be performed on the Controller.

Dimensions	30 × 100 × 71 mm (W×H×D)	Isolation method	External inputs: Photocoupler isolation External outputs: Digital isolator
Insulation resistance	20 MΩ min. between isolated circuits (at 100 VDC)	Dielectric strength	510 VAC between isolated circuits for 1 minute at a leakage current of 5 mA max.
I/O power supply method	Supply from external source 20.4 to 28.8 VDC (24 VDC +20%, -15%)	Current capacity of I/O power supply terminals	Without I/O power supply terminals
NX Unit power consumption	<ul style="list-style-type: none"> Connected to a CPU Unit 1.65 W max. Connected to a Communications Coupler Unit 1.30 W max. 	Current consumption from I/O power supply	50 mA/CN max.
Weight	150 g max.	Cable length	Line driver outputs: 10 m max. Other I/O: 3 m max.

Circuit layout

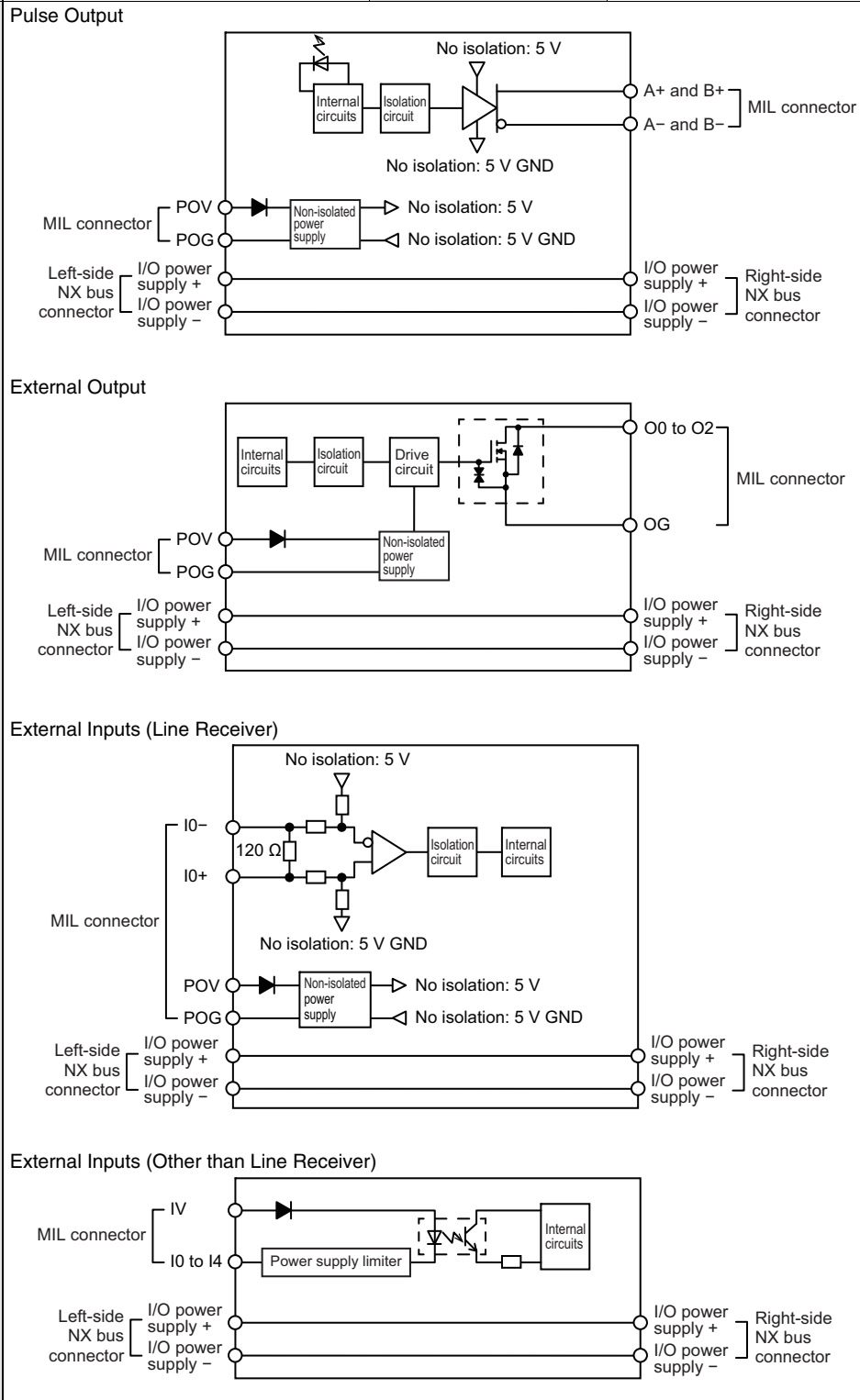

Installation orientation and restrictions

Installation orientation:

- Connected to a CPU Unit: Possible in upright installation.
- Connected to a Communications Coupler Unit: Possible in 6 orientations.

Restrictions: The number of external inputs that can be always ON is restricted as shown below.

- For upright installation

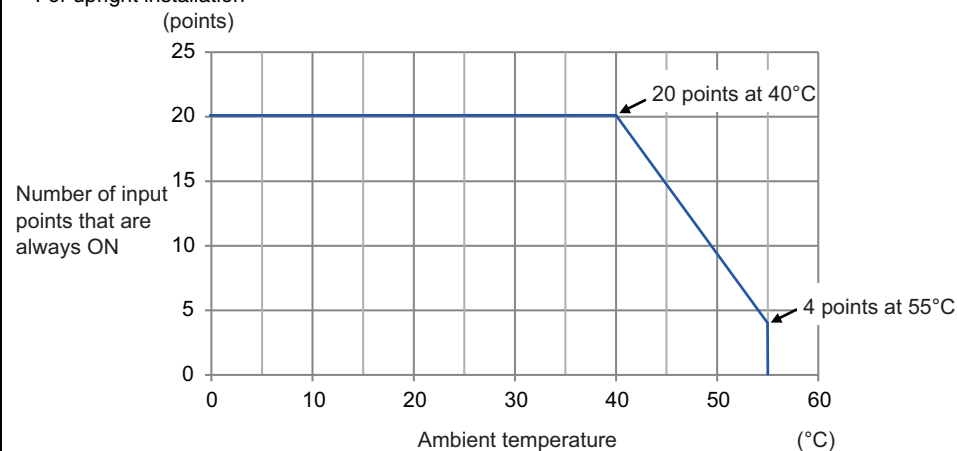

- For any installation other than upright

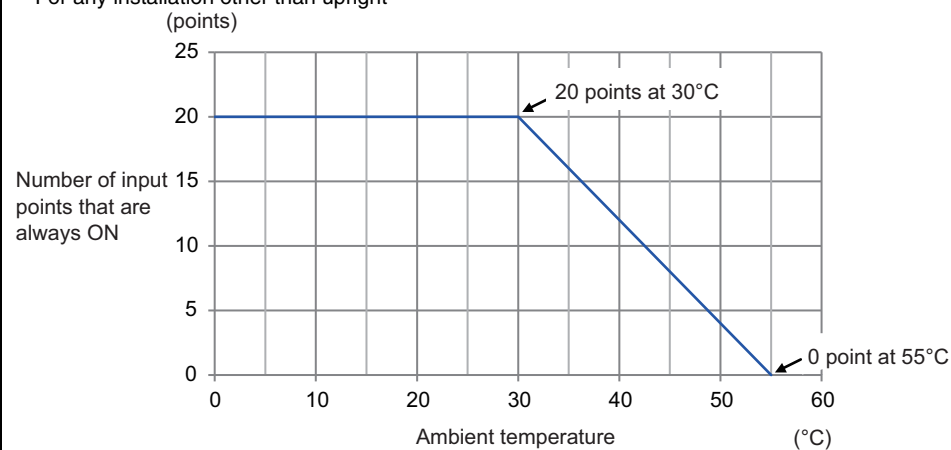

Terminal connection diagram

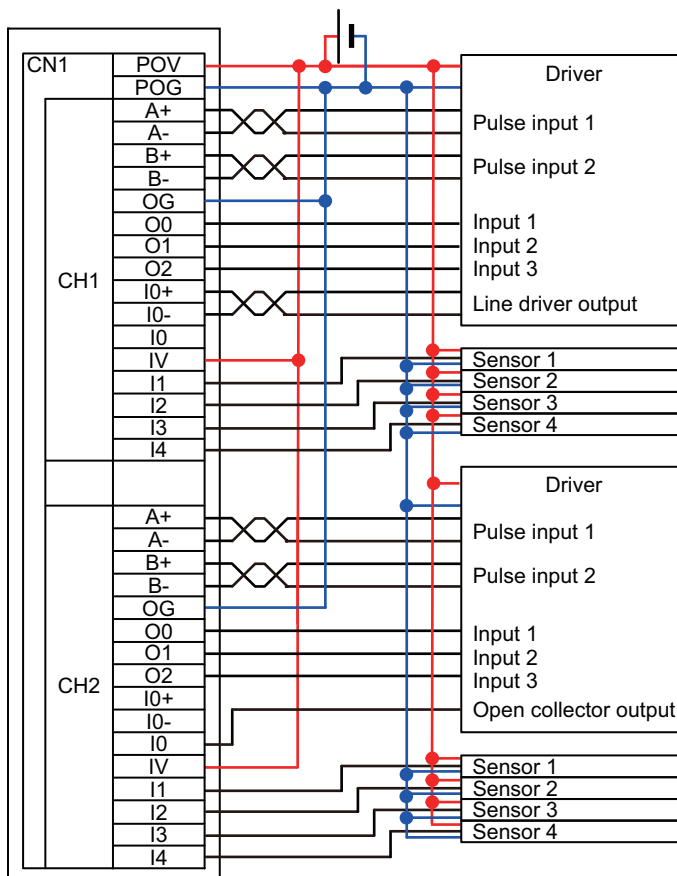

• The connection diagram for CN2 is the same as the one for CN1.

Failure detection	None	Protection	None
--------------------------	------	-------------------	------

Pulse Output Units (Line driver output, PNP type) 4 channels NX-PG0342-5

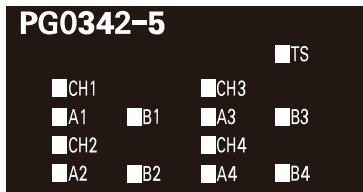
Unit name	Pulse Output Units		Model	NX-PG0342-5
Number of channels	4 channels		External connection terminals	MIL connector (34 terminals x2)
I/O refreshing method*1	Synchronous I/O refreshing or task period prioritized refreshing			
Indicators			I/O signals	Inputs: 5 per channel. External inputs*2 Outputs: 5 per channel. 1 forward direction pulse output, 1 reverse direction pulse output, and 3 external outputs (per channel)*3
Control method	Open-loop control through pulse string output			
Controlled drive	Servo drive with a pulse string input or a stepper motor drive			
Pulse output form	Line driver output			
Unit of control	Pulses			
Maximum pulse output speed	4 Mpps			
Pulse output method	Forward/reverse direction pulse outputs, Pulse + direction outputs, or Phase differential pulse output multiplication x1/2/4			
Position control range	-2,147,483,648 to 2,147,483,647 pulses			
Velocity control range	1 to 4,000,000 pps			
Positioning*4				
Single-axis position control	Absolute positioning, relative positioning, and interrupt feeding			
Single-axis velocity control	Velocity control (velocity feeding in Position Control Mode)			
Single-axis synchronized control	Cam operation and gear operation			
Single-axis manual operation	Jogging			
Auxiliary function for single-axis control	Homing, stopping, and override changes			
External input specifications (except for line receiver inputs)				
Input voltage	21.6 to 26.4 VDC (24 VDC +10%, -10%)	ON voltage/ON current	15 VDC min./3 mA min.	
Input current	4.6 mA typical (24 VDC)	OFF voltage/OFF current	4.0 VDC max./1 mA max.	
ON/OFF response time	External inputs 0 and 1: 1 μs max./2 μs max. External inputs 2 to 4: 20 μs max./400 μs max.			
Internal I/O common processing	PNP			
External input specifications (line receiver inputs)				
Input voltage	EIA standard RS-422-A line driver levels	High level input voltage	VIT+: 0.1 V min.	
Input impedance	120 Ω ± 5%	Low level input voltage	VIT-: -0.1 V max.	
Hysteresis voltage	V _{hys} (VIT+ - VIT-): 60 mV			
Line driver output specifications				
Output voltage	RS-422-A line driver level (equivalent to AM26C31)			
Maximum load current	20 mA			
Maximum output frequency	4 Mpps			
External output specifications				
Rated voltage	24 VDC			
Load voltage range	15 to 28.8 VDC	Residual voltage	1.0 V max.	
Maximum load current	30 mA	Leakage current	0.1 mA max.	
ON/OFF response time	External output 0: 5 μs max./200 μs max. External outputs 1 and 2: 0.5 ms max./1 ms max.			
Internal I/O common processing	PNP			

*1. The I/O refreshing method is set according to the connected Communications Coupler Unit and CPU Unit.

*2. You can use the external input 0 as a latch input.

*3. You can use the external output 0 as an error counter reset output.

*4. These functions are supported when you also use the MC Function Module in the NJ/NX-series CPU Unit or the NY-series Industrial PC. For details, refer to the motion control user's manual for the connected CPU Unit or Industrial PC.

A Pulse Output Unit only outputs pulses during the control period based on commands received at a fixed period.

Target position calculations (distribution calculations) for acceleration/deceleration control or for each control period must be performed on the Controller.

Dimensions	30 × 100 × 71 mm (W×H×D)	Isolation method	External inputs: Photocoupler isolation External outputs: Digital isolator
Insulation resistance	20 MΩ min. between isolated circuits (at 100 VDC)	Dielectric strength	510 VAC between isolated circuits for 1 minute at a leakage current of 5 mA max.
I/O power supply method	Supply from external source 20.4 to 28.8 VDC (24 VDC +20%, -15%)	Current capacity of I/O power supply terminals	Without I/O power supply terminals
NX Unit power consumption	<ul style="list-style-type: none"> Connected to a CPU Unit 1.65 W max. Connected to a Communications Coupler Unit 1.30 W max. 	Current consumption from I/O power supply	50 mA/CN max.
Weight	150 g max.	Cable length	Line driver outputs: 10 m max. Other I/O: 3 m max.

Circuit layout

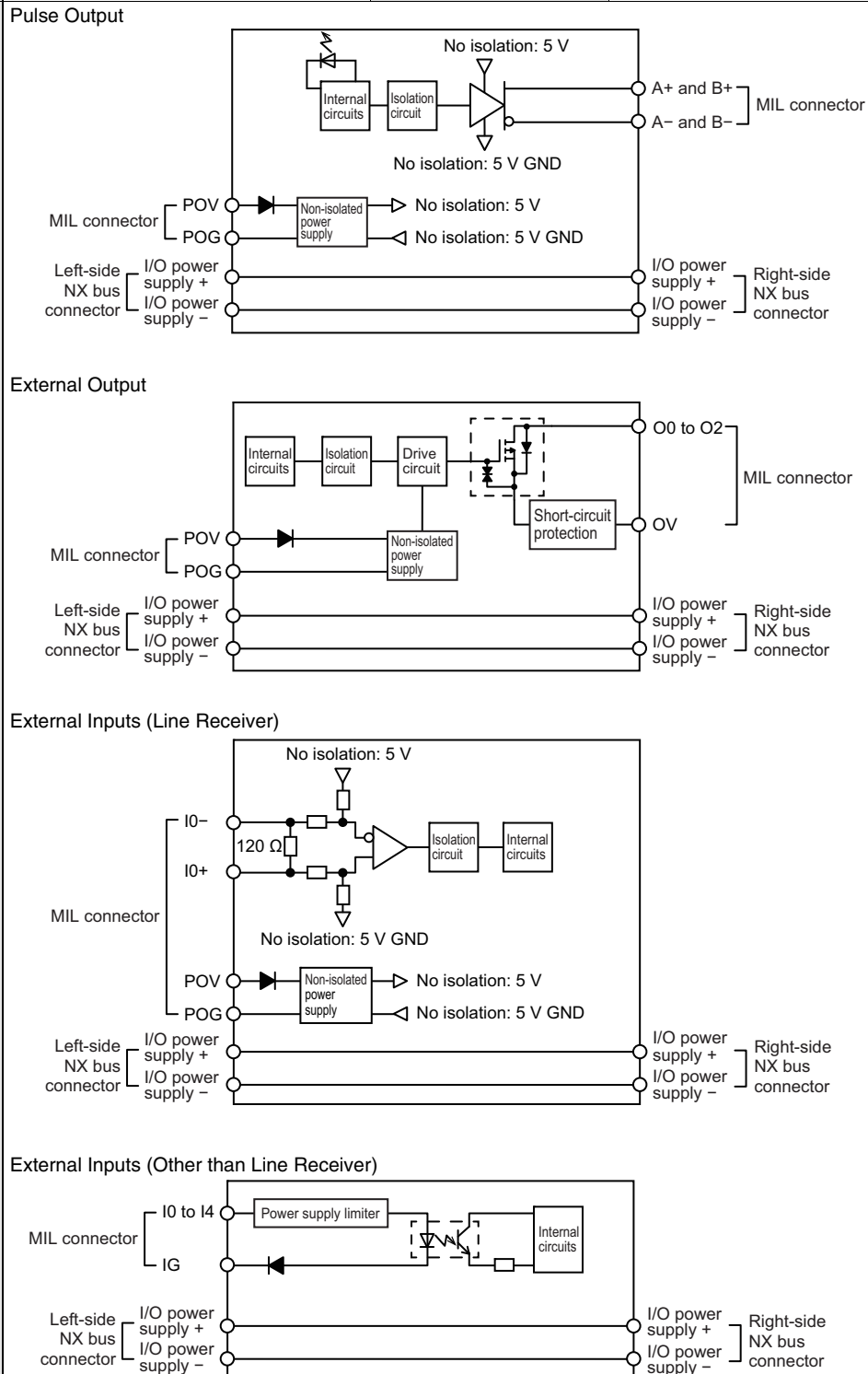

Installation orientation and restrictions

Installation orientation:

- Connected to a CPU Unit: Possible in upright installation.
- Connected to a Communications Coupler Unit: Possible in 6 orientations.

Restrictions: The number of external inputs that can be always ON is restricted as shown below.

- For upright installation

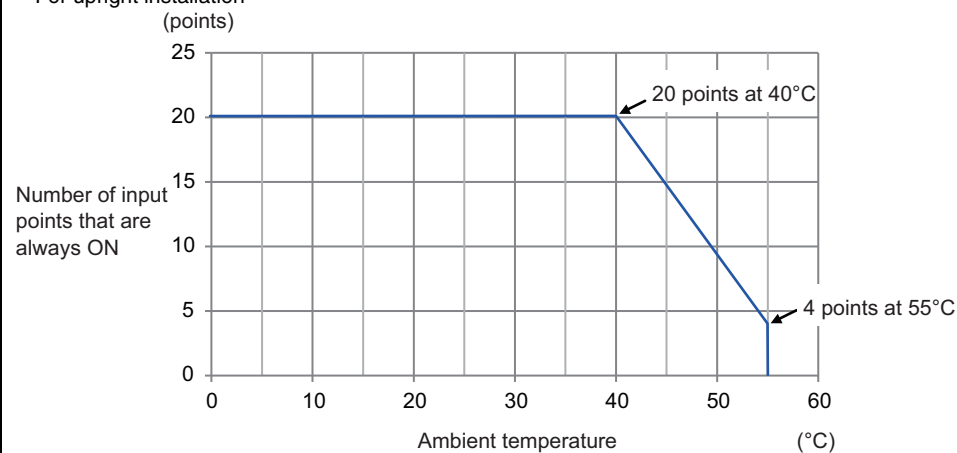

- For any installation other than upright

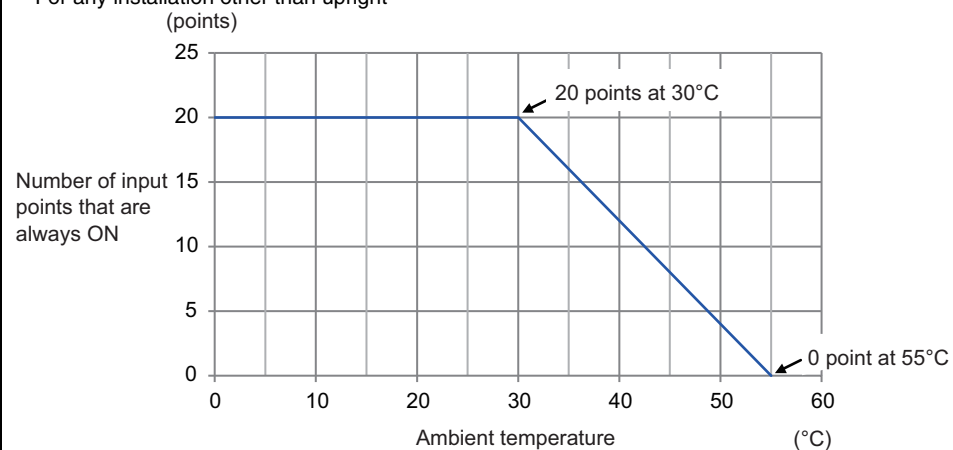

Terminal connection diagram

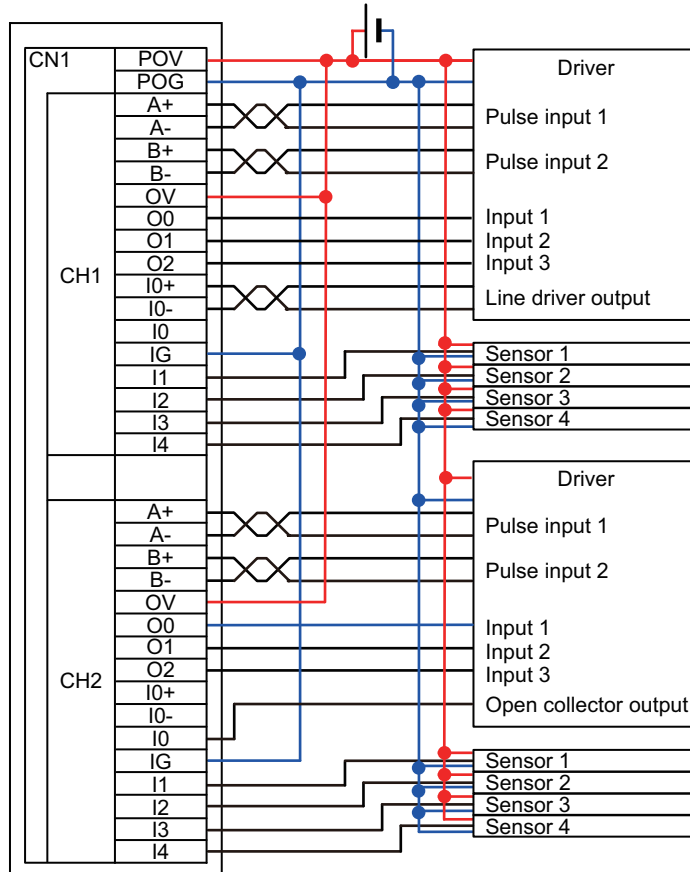

• The connection diagram for CN2 is the same as the one for CN1.

Failure detection	None	Protection	None
--------------------------	------	-------------------	------

Version Information

Connecting with CPU Units

Refer to the user's manuals for the CPU Unit for details on the CPU Units to which NX Units can be connected.

NX Unit		Corresponding versions *	
Model	Unit Version	CPU Unit	Sysmac Studio
NX-PG0112	Ver.1.1	Ver.1.13 or later	Ver.1.17 or higher
	Ver.1.2		
NX-PG0122	Ver.1.0		
	Ver.1.1		
	Ver.1.2		
NX-PG0232-5	Ver.1.2		
NX-PG0242-5			
NX-PG0332-5			
NX-PG0342-5			

* Some Units do not have all of the versions given in the above table. If a Unit does not have the specified version, support is provided by the oldest available version after the specified version. Refer to the user's manuals for the specific Units for the relation between models and versions.

Connecting with Coupler Units

NX Unit		Corresponding versions *1				
Model	Unit Version	EtherCAT		EtherNet/IP		
		Communications Coupler Unit	NJ/NX-series CPU Units or NY-series Industrial PCs	Sysmac Studio	Communications Coupler Unit	Sysmac Studio
NX-PG0112	Ver.1.1	Ver.1.0 or later	Ver.1.05 or later	Ver.1.10 or higher	---	---
	Ver.1.2	Ver.1.3 or later *2 *3		Ver.1.13 or higher		
NX-PG0122	Ver.1.0	Ver.1.0 or later		Ver.1.06 or higher		
	Ver.1.1			Ver.1.08 or higher		
	Ver.1.2	Ver.1.13 or higher				
NX-PG0232-5	Ver.1.2	Ver.1.3 or later *2 *3		Ver.1.15 or higher		
NX-PG0242-5						
NX-PG0332-5						
NX-PG0342-5						

*1. Some Units do not have all of the versions given in the above table. If a Unit does not have the specified version, support is provided by the oldest available version after the specified version. Refer to the user's manuals for the specific Units for the relation between models and versions.

*2. To use task period prioritized refreshing, you must use the NX-ECC203.

*3. If you do not use task period prioritized refreshing, you can use EtherCAT Coupler Units with unit version 1.0.

External Interface

Open collector output Type

NX-PG0112/-PG0122

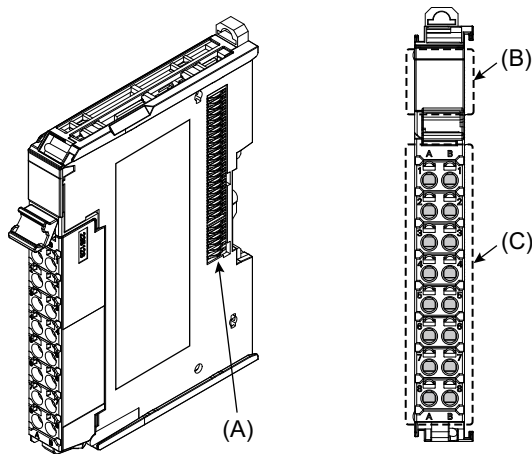

Letter	Item	Specification
(A)	NX bus connector	This connector is used to connect to another Unit.
(B)	Indicators	The indicators show the current operating status of the Unit.
(C)	Terminal block	The terminal block is used to connect to external devices. The number of terminals depends on the Unit.

Terminal Blocks

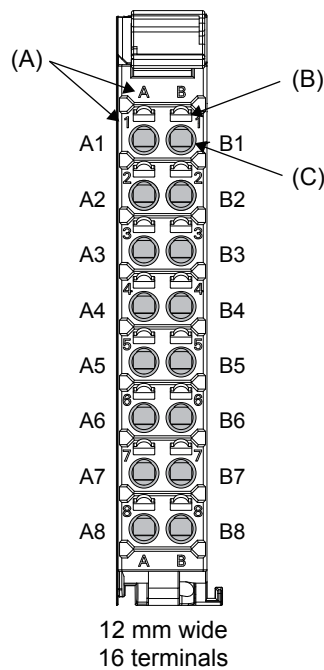

Letter	Item	Specification
(A)	Terminal number indication	The terminal number is identified by a column (A and B) and a row (1 through 8). Therefore, terminal numbers are written as a combination of columns and rows, A1 through A8 and B1 through B8. The terminal number indication is the same regardless of the number of terminals on the terminal block, as shown above.
(B)	Release hole	A flat-blade screwdriver is inserted here to attach and remove the wiring.
(C)	Terminal hole	The wires are inserted into these holes.

Applicable Terminal Blocks for Each Unit Model

Unit model	Terminal Blocks				
	Model	No. of terminals	Terminal number indications	Ground terminal mark	Terminal current capacity
NX-PG0112 NX-PG0122	NX-TBA162	16	A/B	None	10 A

Applicable Wires

Using Ferrules

If you use ferrules, attach the twisted wires to them.

Observe the application instructions for your ferrules for the wire stripping length when attaching ferrules.

Always use plated one-pin ferrules. Do not use unplated ferrules or two-pin ferrules.

The applicable ferrules, wires, and crimping tool are given in the following table.

Terminal types	Manufacturer	Ferrule model	Applicable wire (mm ² (AWG))	Crimping tool
Terminals other than ground terminals	Phoenix Contact	AI0,34-8	0.34 (#22)	Phoenix Contact (The figure in parentheses is the applicable wire size.) CRIMPFOX 6 (0.25 to 6 mm ² , AWG 24 to 10)
		AI0,5-8	0.5 (#20)	
		AI0,5-10		
		AI0,75-8	0.75 (#18)	
		AI0,75-10		
		AI1,0-8	1.0 (#18)	
		AI1,0-10		
		AI1,5-8	1.5 (#16)	
AI1,5-10				
Ground terminals		AI2,5-10	2.0 *1	
Terminals other than ground terminals	Weidmuller	H0.14/12	0.14 (#26)	Weidmuller (The figure in parentheses is the applicable wire size.) PZ6 Roto (0.14 to 6 mm ² , AWG 26 to 10)
		H0.25/12	0.25 (#24)	
		H0.34/12	0.34 (#22)	
		H0.5/14	0.5 (#20)	
		H0.5/16		
		H0.75/14	0.75 (#18)	
		H0.75/16		
		H1.0/14	1.0 (#18)	
		H1.0/16		
		H1.5/14	1.5 (#16)	
H1.5/16				

*1. Some AWG 14 wires exceed 2.0 mm² and cannot be used in the screwless clamping terminal block.

When you use any ferrules other than those in the above table, crimp them to the twisted wires so that the following processed dimensions are achieved.

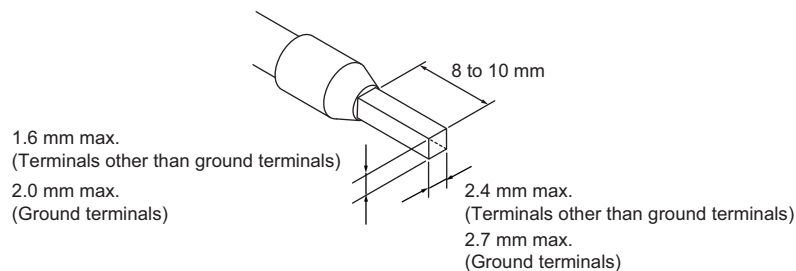

Using Twisted Wires/Solid Wires

If you use the twisted wires or the solid wires, use the following table to determine the correct wire specifications.

Terminals		Wire type				Wire size	Conductor length (stripping length)
		Twisted wires		Solid wire			
Classification	Current capacity	Plated	Unplated	Plated	Unplated		
All terminals except ground terminals	2 A max.	Possible	Possible	Possible	Possible	0.08 to 1.5 mm ² AWG28 to 16	8 to 10 mm
	Greater than 2 A and 4 A or less		Not Possible	*1	Not Possible		
	Greater than 4 A	*1		Not Possible			
Ground terminals	---	Possible	Possible	*2	*2	2.0 mm ²	9 to 10 mm

*1. Secure wires to the screwless clamping terminal block. Refer to the Securing Wires in the USER'S MANUAL for how to secure wires.

*2. With the NX-TB□□□1 Terminal Block, use twisted wires to connect the ground terminal. Do not use a solid wire.

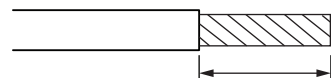

Conductor length (stripping length)

<Additional Information> If more than 2 A will flow on the wires, use plated wires or use ferrules.

Line driver output Types

NX-PG0232-5/-PG0242-5

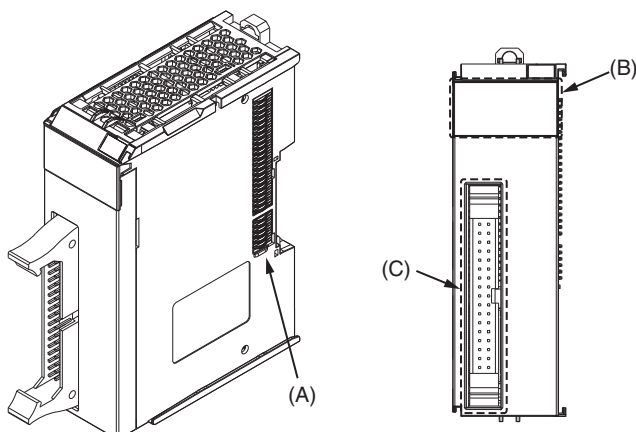

NX-PG0332-5/-PG0342-5

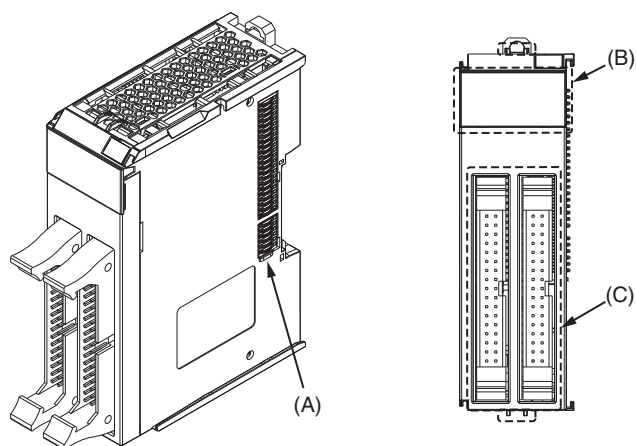

Letter	Item	Specification
(A)	NX bus connector	This connector is used to connect to another Unit.
(B)	Indicators	The indicators show the current operating status of the Unit.
(C)	Terminal block	The connectors are used to connect to external devices. The number of 34-terminals depends on the Unit.

Connecting to Connector-Terminal Block Conversion Units

Connection Examples

(a) NX-PG0232-5 and NX-PG0242-5

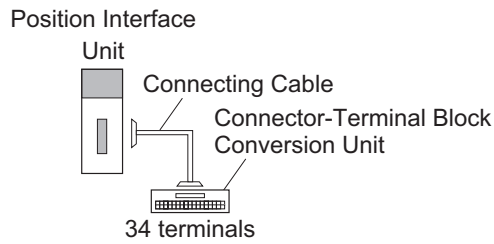

(b) NX-PG0332-5 and NX-PG0342-5

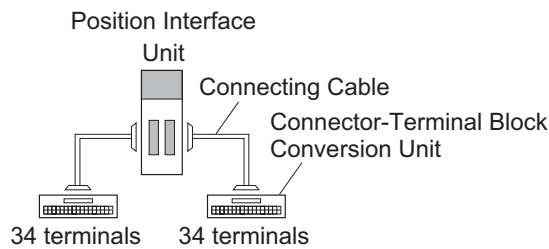

Connecting Cable

The table below shows applicable connecting cables.

Model	Manufacturer
XW2Z-□□□EE	OMRON Corporation

The cable length from the Unit to an external device connected through the Connector-Terminal Block Conversion Units should not be longer than the specified cable length for the Unit.

Refer to the Specification for each units.

Connector-Terminal Block Conversion Unit

The table below shows applicable Connector-Terminal Block Conversion Units.

Model	Manufacturer
XW2B-34G4	OMRON Corporation
XW2B-34G5	
XW2D-34G6	
XW2R-J34GD-T	
XW2R-E34GD-T	
XW2R-P34GD-T	

Each of NX-PG0232-5 and NX-PG0242-5 has one MIL connector. Therefore, one Connector-Terminal Block Conversion Unit is required.

Each of NX-PG0332-5 and NX-PG0342-5 has two MIL Connectors. Therefore, two Connector-Terminal Block Conversion Units are required.

Dimensions

Open collector output Types

NX-PG0112/-PG0122

12 mm Width

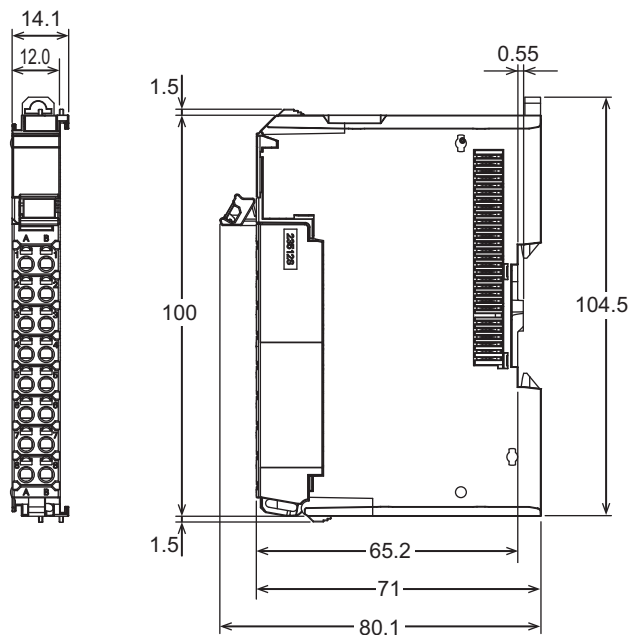

Line driver output Types

NX-PG0232-5/-PG0242-5

30 mm Width

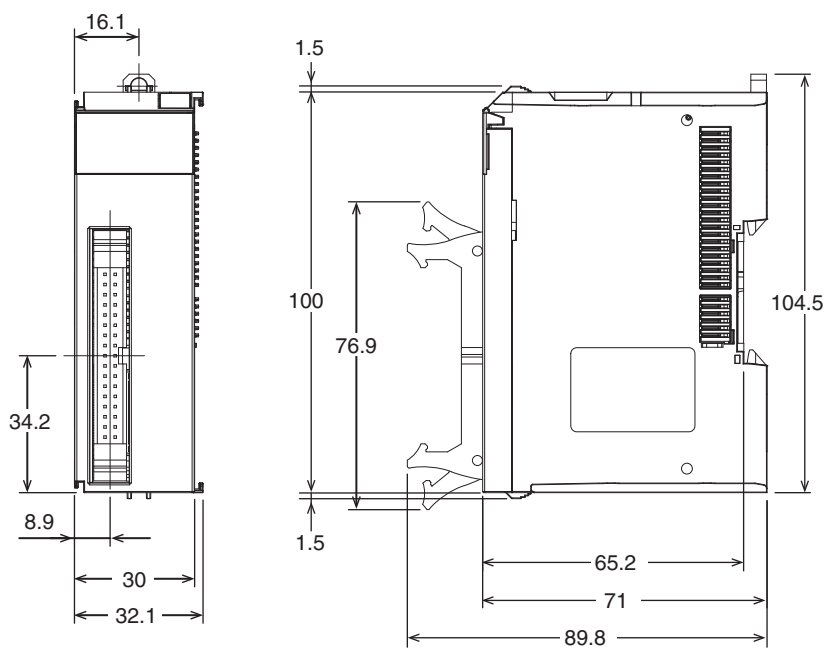

NX-PG0332-5/-PG0342-5
30 mm Width

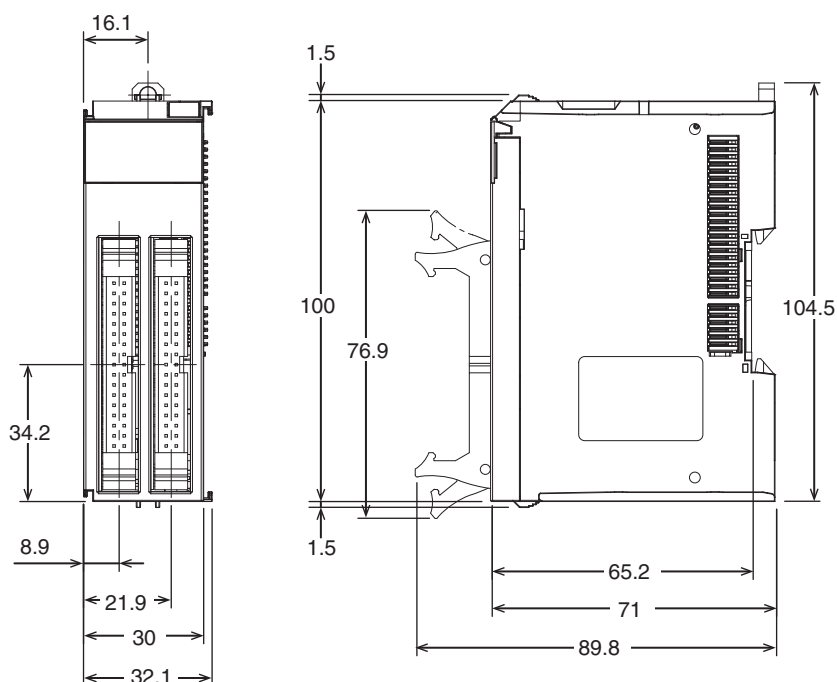

Related Manuals

Man. No	Model	Manual	Application	Description
W524	NX-EC0□□□ NX-ECS□□□ NX-PG0□□□	NX-series Position Interface Units User's Manual	Learning how to use NX-series Position Interface Units	The hardware, setup methods, and functions of the NX-series Incremental Encoder Input Units, SSI Input Units, and Pulse Output Unit are described.
W507	NX701-□□□□ NJ501-□□□□ NJ301-□□□□ NJ101-□□□□ NX1P2-□□□□	NJ/NX-series CPU Unit Motion Control User's Manual	Learning about motion control settings and programming concepts.	The settings and operation of the CPU Unit and programming concepts for motion control are described. When programming, use this manual together with the <i>NJ-series CPU Unit Hardware User's Manual</i> (Cat. No. W500) or <i>NX-series CPU Unit Hardware User's Manual</i> (Cat. No. W535) and with the <i>NJ/NX-series CPU Unit Software User's Manual</i> (Cat. No. W501).
W559	NY532-□□□□ NY512-□□□□	NY-series IPC Machine Controller Industrial Panel PC / Industrial Box PC Motion Control User's Manual	Learning about motion control settings and programming concepts of an NY-series Industrial PC.	The settings and operation of the Controller and programming concepts for motion control are described.

Terms and Conditions Agreement

Read and understand this catalog.

Please read and understand this catalog before purchasing the products. Please consult your OMRON representative if you have any questions or comments.

Warranties.

(a) Exclusive Warranty. Omron's exclusive warranty is that the Products will be free from defects in materials and workmanship for a period of twelve months from the date of sale by Omron (or such other period expressed in writing by Omron). Omron disclaims all other warranties, express or implied.

(b) Limitations. OMRON MAKES NO WARRANTY OR REPRESENTATION, EXPRESS OR IMPLIED, ABOUT NON-INFRINGEMENT, MERCHANTABILITY OR FITNESS FOR A PARTICULAR PURPOSE OF THE PRODUCTS. BUYER ACKNOWLEDGES THAT IT ALONE HAS DETERMINED THAT THE PRODUCTS WILL SUITABLY MEET THE REQUIREMENTS OF THEIR INTENDED USE.

Omron further disclaims all warranties and responsibility of any type for claims or expenses based on infringement by the Products or otherwise of any intellectual property right. (c) Buyer Remedy. Omron's sole obligation hereunder shall be, at Omron's election, to (i) replace (in the form originally shipped with Buyer responsible for labor charges for removal or replacement thereof) the non-complying Product, (ii) repair the non-complying Product, or (iii) repay or credit Buyer an amount equal to the purchase price of the non-complying Product; provided that in no event shall Omron be responsible for warranty, repair, indemnity or any other claims or expenses regarding the Products unless Omron's analysis confirms that the Products were properly handled, stored, installed and maintained and not subject to contamination, abuse, misuse or inappropriate modification. Return of any Products by Buyer must be approved in writing by Omron before shipment. Omron Companies shall not be liable for the suitability or unsuitability or the results from the use of Products in combination with any electrical or electronic components, circuits, system assemblies or any other materials or substances or environments. Any advice, recommendations or information given orally or in writing, are not to be construed as an amendment or addition to the above warranty.

See <http://www.omron.com/global/> or contact your Omron representative for published information.

Limitation on Liability; Etc.

OMRON COMPANIES SHALL NOT BE LIABLE FOR SPECIAL, INDIRECT, INCIDENTAL, OR CONSEQUENTIAL DAMAGES, LOSS OF PROFITS OR PRODUCTION OR COMMERCIAL LOSS IN ANY WAY CONNECTED WITH THE PRODUCTS, WHETHER SUCH CLAIM IS BASED IN CONTRACT, WARRANTY, NEGLIGENCE OR STRICT LIABILITY.

Further, in no event shall liability of Omron Companies exceed the individual price of the Product on which liability is asserted.

Suitability of Use.

Omron Companies shall not be responsible for conformity with any standards, codes or regulations which apply to the combination of the Product in the Buyer's application or use of the Product. At Buyer's request, Omron will provide applicable third party certification documents identifying ratings and limitations of use which apply to the Product. This information by itself is not sufficient for a complete determination of the suitability of the Product in combination with the end product, machine, system, or other application or use. Buyer shall be solely responsible for determining appropriateness of the particular Product with respect to Buyer's application, product or system. Buyer shall take application responsibility in all cases.

NEVER USE THE PRODUCT FOR AN APPLICATION INVOLVING SERIOUS RISK TO LIFE OR PROPERTY OR IN LARGE QUANTITIES WITHOUT ENSURING THAT THE SYSTEM AS A WHOLE HAS BEEN DESIGNED TO ADDRESS THE RISKS, AND THAT THE OMRON PRODUCT(S) IS PROPERLY RATED AND INSTALLED FOR THE INTENDED USE WITHIN THE OVERALL EQUIPMENT OR SYSTEM.

Programmable Products.

Omron Companies shall not be responsible for the user's programming of a programmable Product, or any consequence thereof.

Performance Data.

Data presented in Omron Company websites, catalogs and other materials is provided as a guide for the user in determining suitability and does not constitute a warranty. It may represent the result of Omron's test conditions, and the user must correlate it to actual application requirements. Actual performance is subject to the Omron's Warranty and Limitations of Liability.

Change in Specifications.

Product specifications and accessories may be changed at any time based on improvements and other reasons. It is our practice to change part numbers when published ratings or features are changed, or when significant construction changes are made. However, some specifications of the Product may be changed without any notice. When in doubt, special part numbers may be assigned to fix or establish key specifications for your application. Please consult with your Omron's representative at any time to confirm actual specifications of purchased Product.

Errors and Omissions.

Information presented by Omron Companies has been checked and is believed to be accurate; however, no responsibility is assumed for clerical, typographical or proofreading errors or omissions.

X-ON Electronics

Largest Supplier of Electrical and Electronic Components

Click to view similar products for [Controllers](#) category:

Click to view products by [Omron](#) manufacturer:

Other Similar products are found below :

[61FGPN8DAC120](#) [CV500SLK21](#) [70177-1011](#) [F03-03 HAS C](#) [F03-31](#) [81550401](#) [FT1A-C12RA-W](#) [88981106](#) [H2CAC24A](#) [H2CRSAC110B](#)
[R88A-CRGB003CR-E](#) [R88ARR080100S](#) [R88A-TK01K](#) [DCN1-1](#) [DRT2ID08C](#) [DTB4896VRE](#) [DTB9696CVE](#) [DTB9696LVE](#) [E53-AZ01](#)
[E53E01](#) [E53E8C](#) [E5C4Q40J999FAC120](#) [E5CWLQ1TCAC100240](#) [E5GNQ03PFLKACDC24](#) [B300LKL21](#) [NSCXDC1V3](#) [NSH5-232CW-3M](#)
[NT20SST122BV1](#) [NV-CN001](#) [OAS-160-N](#) [C40PEDRA](#) [K31S6](#) [K33-L1B](#) [K3MA-F](#) [100-240VAC](#) [K3TX-AD31A](#) [89750101](#) [L595020](#)
[SRM1-C02](#) [SRS2-1](#) [FT1A-C14SA-S](#) [G32X-V2K](#) [26546803](#) [26546805](#) [PWRA440A](#) [CPM1AETL03CH](#) [CV500SLK11](#) [3G2A5BI081](#)
[3G2A5IA122](#) [3G2A5LK010E](#) [3G2A5OA223](#)