

**OMRON Corporation****FA Systems Division H.Q.**

66 Matsumoto  
Mishima-city, Shizuoka 411-8511  
Japan  
Tel: (81)559-77-9181/Fax: (81)559-77-9045

**Regional Headquarters****OMRON EUROPE B.V.**

Wegalaan 67-69, NL-2132 JD Hoofddorp  
The Netherlands  
Tel: (31)2356-81-300/Fax: (31)2356-81-388

**OMRON ELECTRONICS LLC**

1 East Commerce Drive, Schaumburg, IL 60173  
U.S.A.  
Tel: (1)847-843-7900/Fax: (1)847-843-8568

**OMRON ASIA PACIFIC PTE. LTD.**

83 Clemenceau Avenue,  
#11-01, UE Square,  
Singapore 239920  
Tel: (65)835-3011/Fax: (65)835-2711

**Authorized Distributor:**

# CompoBus/S

**New Products**

- Programmable Slaves
- SYSMAC CPM2C CPU Units with CompoBus/S Master Functions
- Waterproof Terminals
- Sensor Terminals
- Remote I/O Modules

# Complicated and Time-consuming Wiring,...

**Complicated wiring between the PC and repeater terminal block.**

**System expansion is time-consuming.**

**Transmission of ON/OFF signals is time-consuming.**

**Complicated sensor wiring.**

**Large wiring effort required for distributed devices handling only a small number of I/O points.**

■ Features	2
■ Maintenance	4
■ Programmable Slaves	6
■ CompoBus/S Products	8
■ Connections to a Wider Range of Slaves Ensured by Upgraded Models	12
■ CPM2C-S1□DC CPU Units with CompoBus/S Master	14
■ CPM2C-S1□DC-DRT Programmable Slaves	18
■ SRM1-C01-V2/C02-V2 Master Control Units (S-Controllers)	22
■ C200HW-SRM21-V1 Master Unit	25
■ CQM1-SRM21-V1 Master Unit	27
■ C200PC-ISA□3-SRM SYSMAC Boards with CompoBus/S Master	30
■ CPM2C-SRT21 I/O Link Unit	32
■ CPM1A-SRT21 I/O Link Unit	34
■ SRT2-ID/OD(-1) Transistor Remote I/O Terminals	35
■ SRT2-D16T(-1) Transistor Remote I/O Terminals with 3-tier Terminal Block	42
■ SRT2-R Relay-mounted Remote I/O Terminals	45
■ SRT2-D32ML(-1) Transistor Remote I/O Terminals with Connectors (32 Points)	51
■ SRT2-VID/VOD(-1) Transistor Remote I/O Terminals with Connectors (8/16 Points)	59
■ SRT2-D0□CL(-1) Waterproof Terminals	66
■ SRT2-D08S Sensor Terminals	72
■ SRT1-□□04S CompoBus/S Sensor Amplifier Terminals	80
■ SRT2-AD04 Analog Input Terminal	93
■ SRT2-DA02 Analog Output Terminal	96
■ SRT2-ID16P/OD16P Remote I/O Modules	99
■ FND-X□-SRT Position Drivers	102
■ Peripheral Devices	105
■ Ordering Information	107

# Now Easier and Quicker

**Maximum Communications Cycle Time of Only 1 ms**  
(High-speed Communications Mode)  
Exchanges 256 I/O points of data with a maximum of 32 Slaves at a maximum communications cycle time of only 1 ms per point.

**Long-distance Communications Mode**  
With a trunk line length of 500 m and a total branch line length of 100 m (2-conductor VCTF cable), you can branch in any way required using a special flat cable or a 4-conductor VCTF cable as long as the total wiring length is 200 m or less. Communicate at a cycle time of only 6 ms.

**Connects through a single dedicated cable, thus greatly saving wiring effort.**  
Cable or flat cable is selectable.  
● Cable is available for multi-drop, T-branch, or multi-branch lines.  
● Flat cable connects to T-branch connectors, thus ensuring ease of system expansion.

**Dedicated cable saves wiring effort without repeater terminal block.**

**A cycle time of 1 ms max. for up to 32 Slaves, 256 I/O points.**

**Easily connects sensors and Slave Units.**

**T-branches allow easy system expansion.**

**Sensor Amplifiers snap on to connect.**

**Distributed processing of a small number of I/O points.**

\*The Long-distance Communications Mode is not supported by the SRT1 Series.

# Long-distance Communications Mode Eliminates Wiring Restrictions for More Efficient System Design

# Greatly Saves Wiring and Installation Effort and Time for System Maintenance and Expansion

## System Design

With conventional High-speed Communications Mode, the following restrictions on the number of branching points and cable length had to be considered when designing the system.

With a Special Flat Cable or a 4-conductor VCTF cable:  
Main line length A: 30 m max. Branch line lengths B, C, and D: 3 m max. Total branch line length B + C + D: 30 m max.

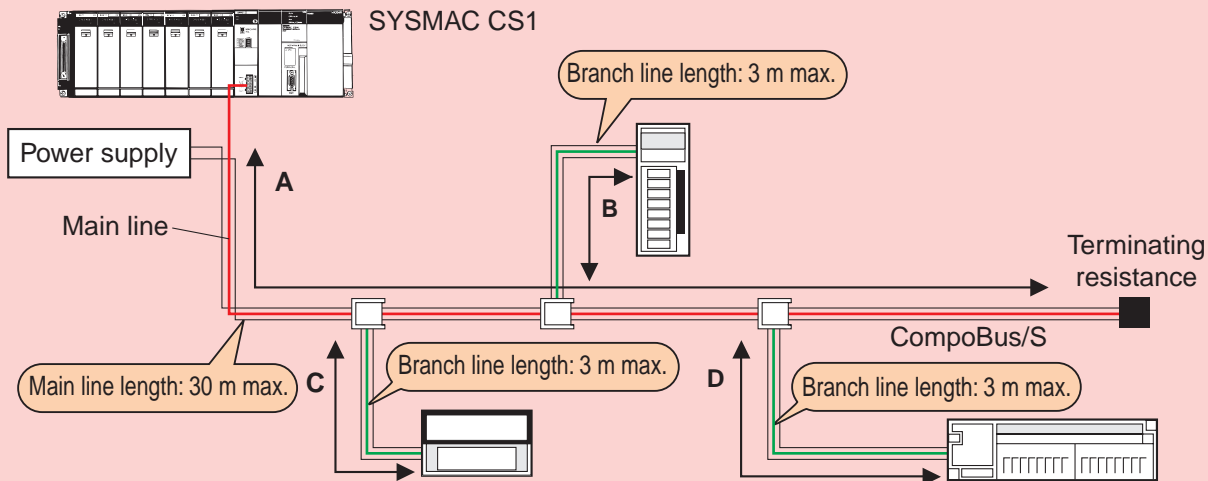

\* Baud rate: 750 kbps (in High-speed Communications Mode)  
\* With 2-conductor VCTF cable (in High-speed Communications Mode), main line length: 100 m max.



Using CompoBus/S Long-distance Communications Mode (with a Special Flat Cable or a 4-conductor VCTF cable) removes restrictions on main and branch line lengths. Branch freely up to a total cable length of 200 m.

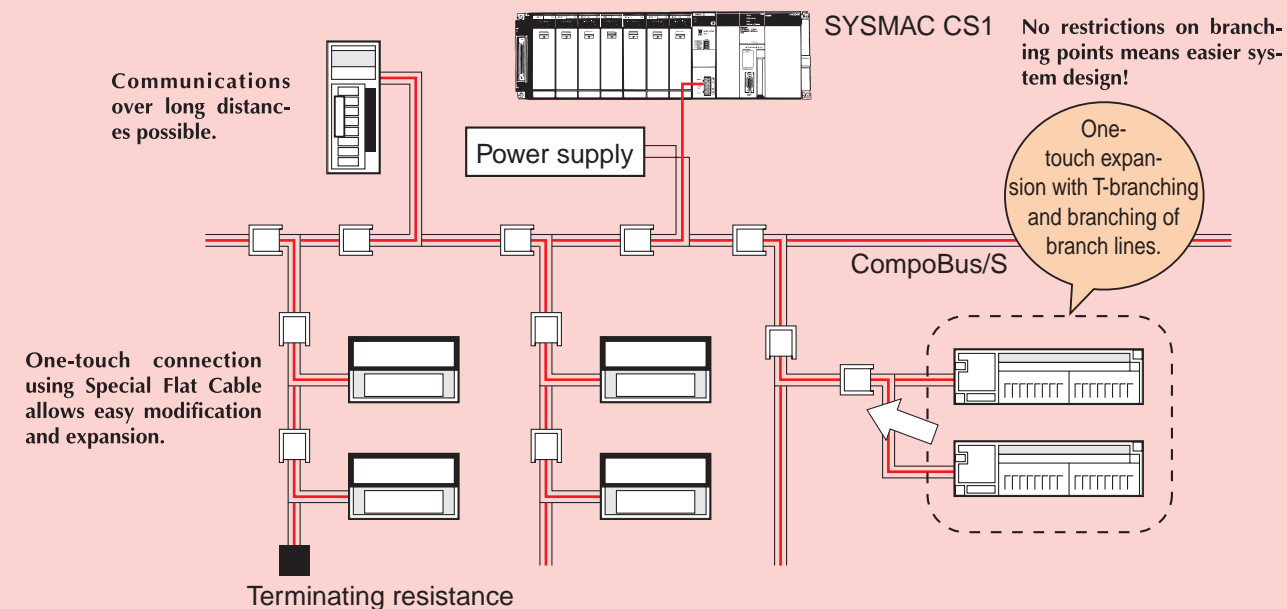

\* Baud rate: 93.75 kbps  
\* Connect a terminating resistance at the end of the cable furthest from the Master.  
\* With 2-conductor VCTF cable (in Long-distance Communications Mode), main line length: 500 m max.

## Maintenance

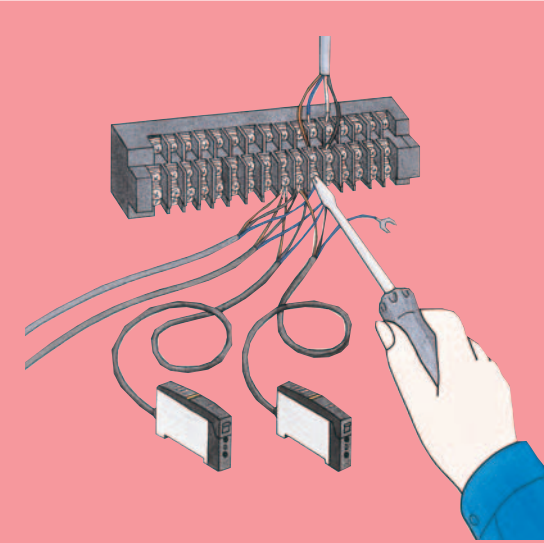

Individual wires must be replaced when using repeater terminal blocks.

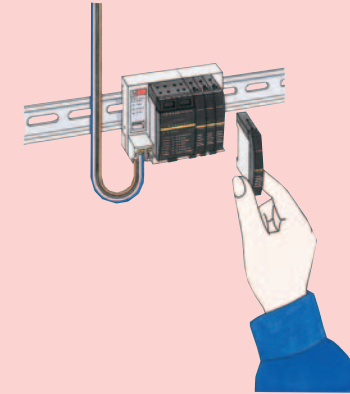

**1** Sensor Amplifier Terminals allow easy replacement of sensors through a snap-on attachment.

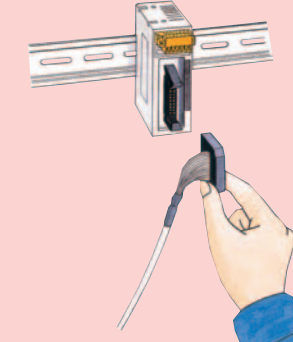

**2** CompoBus/S connector models allow snap-on attachment.

## Expansion

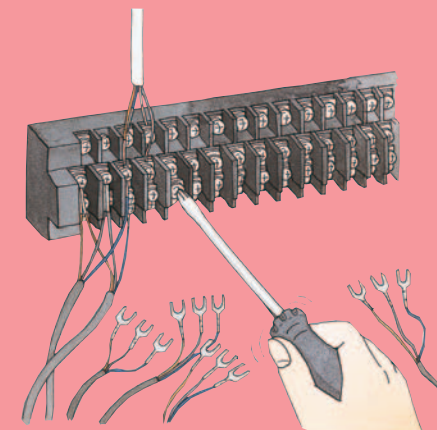

Repeater terminal blocks must be added and wired for I/O expansion.

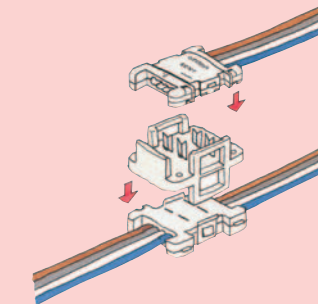

**1** Flat cable can be used with T-branch connectors which allow an increase in the number of Slaves.

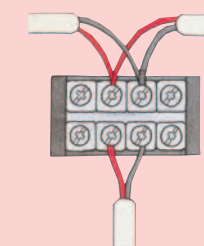

**2** 2-conductor VCTF cable allows multi-branching, thus easily allowing an increase in the number of Slaves.



# Programmable Slaves

## A slave with the complex functional

Programmable Slaves combine devices, such as sensors and actuators, into one functional unit that is treated as a DeviceNet slave.

Programmable Slaves greatly facilitate device distribution and functional organization. They help standardize programming between units and reduce the amount of programming required at the master. I/O and operational checks can be performed for each functional unit, rather than waiting for final system assembly, as with conventional distributed I/O systems.

## ity needed for distributed blocks.

### ● Functions

OMRON Programmable Slaves function as DeviceNet slaves, yet they provide PLC functionality to enable easy system expansion and create new potential.

2-ms Cycle Time  
(for 500 Steps)

High-speed  
Counter

Pulse Output

Interrupt  
Inputs

256  
Timers/  
Counters

Calendar/  
Clock

## DeviceNet™

Multiword I/O links and explicit messages are used to control slaves from the master. Log data for communications can be sent in one operation whenever necessary using explicit messages.

1,024-point  
I/O Links

Explicit  
Messages

DeviceNet-  
CompoBus/S  
Gateway

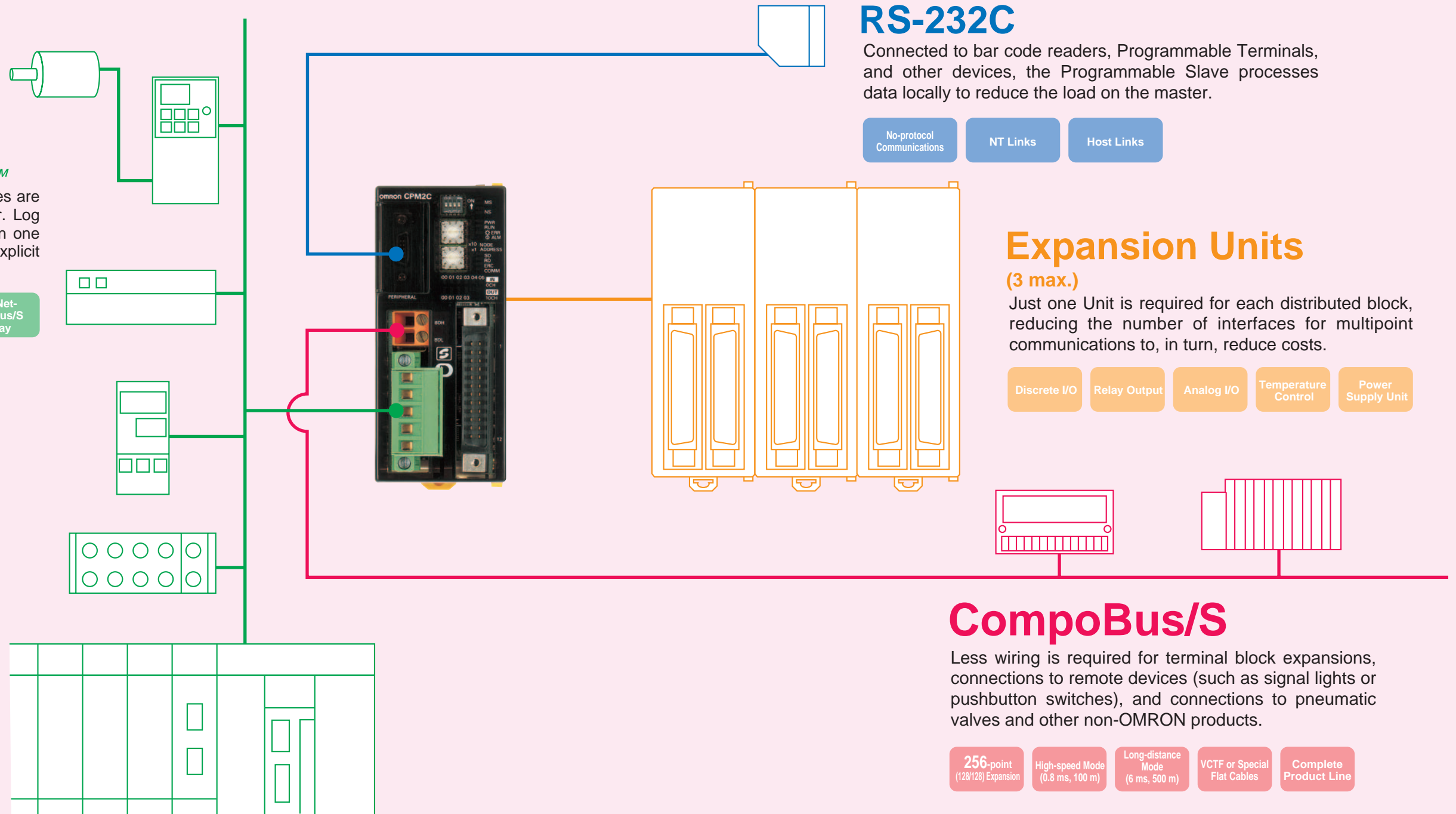

## RS-232C

Connected to bar code readers, Programmable Terminals, and other devices, the Programmable Slave processes data locally to reduce the load on the master.

No-protocol  
Communications

NT Links

Host Links

## Expansion Units

(3 max.)

Just one Unit is required for each distributed block, reducing the number of interfaces for multipoint communications to, in turn, reduce costs.

Discrete I/O

Relay Output

Analog I/O

Temperature  
Control

Power  
Supply Unit

## CompoBus/S

Less wiring is required for terminal block expansions, connections to remote devices (such as signal lights or pushbutton switches), and connections to pneumatic valves and other non-OMRON products.

256-point  
(128/128) Expansion

High-speed Mode  
(0.8 ms, 100 m)

Long-distance  
Mode  
(6 ms, 500 m)

VCTF or Special  
Flat Cables

Complete  
Product Line

# CompoBus/S Products

## Master Units

### CPU Units with CompoBus/S Master

#### Programmable Slaves



CPM2C-S100C  
CPM2C-S110C

CPM2C-S100C-DRT  
CPM2C-S110C-DRT

### CompoBus/S Master Control Units

Without RS-232C port

With RS-232C port



SRM1-C01-V2

SRM1-C02-V2

### CompoBus/S Master Units

Master Unit with 256 points



C200HW-SRM21-V1

Master Unit with 128 points



CQM1-SRM21-V1

### SYSMAC Board with CompoBus/S Master Functions

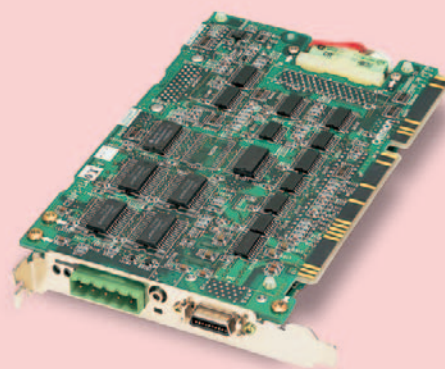

C200PC-ISA□3-SRM

## Slave Units

### I/O Link Units



CPM2C-SRT21



CPM1A-SRT21

### Transistor Remote I/O Terminals (NPN/PNP Output)

SRT2-ID04(-1)  
4 inputs

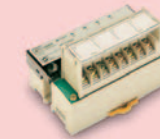

SRT2-ID08(-1)  
8 inputs

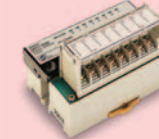

SRT2-ID16(-1)  
16 inputs

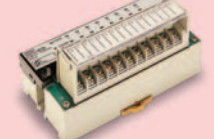

SRT2-OD04(-1)  
4 outputs

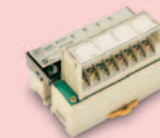

SRT2-OD08(-1)  
8 outputs

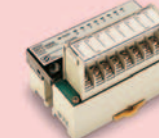

SRT2-OD16(-1)  
16 outputs

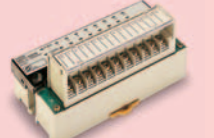

Note: SRT2-□□□□ indicates NPN models and SRT2-□□□□-1 indicates PNP models.

### Transistor Remote I/O Terminals with 3-tier Terminal Block



SRT2-ID16T(-1)

### Relay-mounted Remote I/O Terminals

SRT2-ROC08  
8 relay outputs



SRT2-ROC16  
16 relay outputs



SRT2-ROF08  
8 power MOS FET  
relay outputs



SRT2-ROF16  
16 power MOS FET  
relay outputs

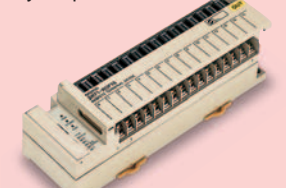

### Transistor Remote I/O Terminals with Connectors



SRT2-□D32ML(-1)  
32 I/O points



SRT2-V□D08S(-1)  
8 I/O points



SRT2-V□D16ML(-1)  
16 I/O points

# CompoBus/S Products

## Slave Units

### Waterproof Terminals

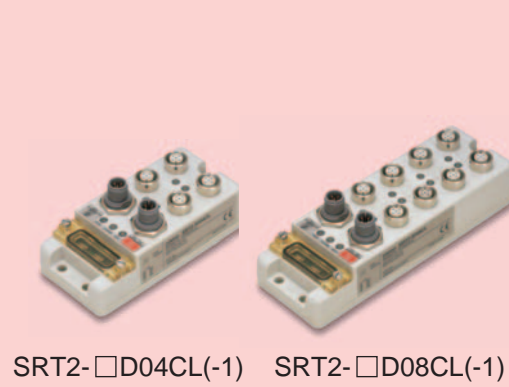

### Sensor Terminals

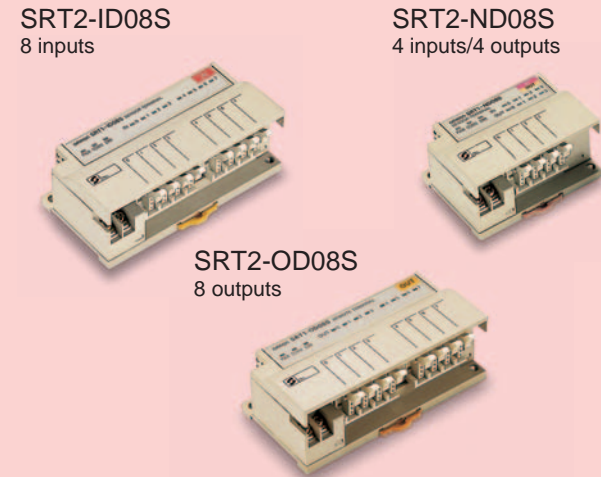

### Sensor Amplifier Terminals

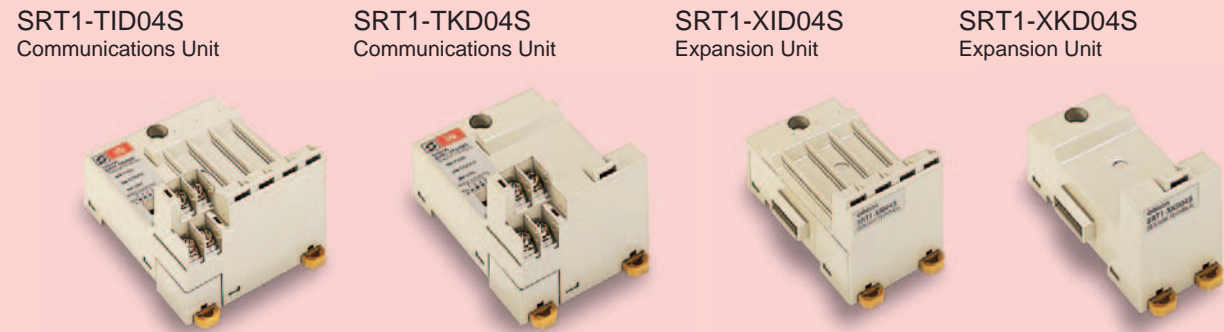

### Connector Units (Photoelectric Sensors)

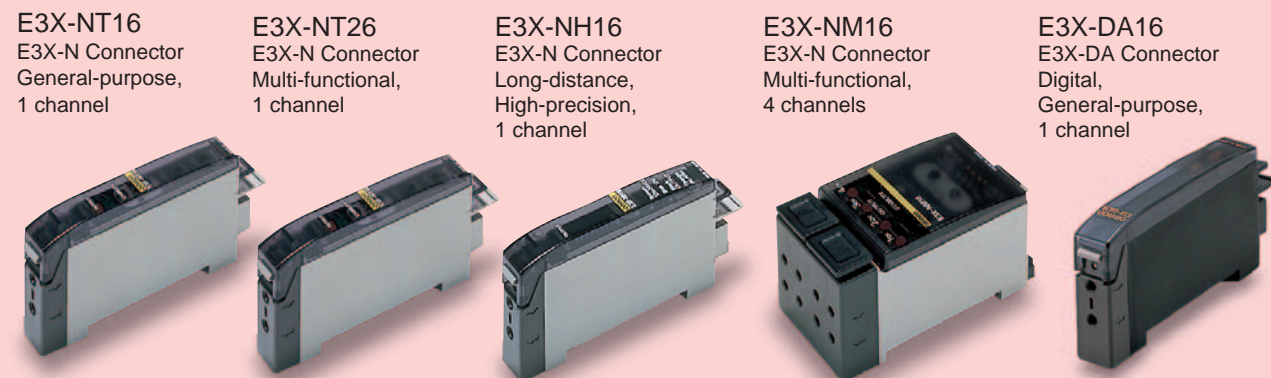

### Connector Unit (Terminal Block Unit)



### Connector Units (Proximity Sensors)

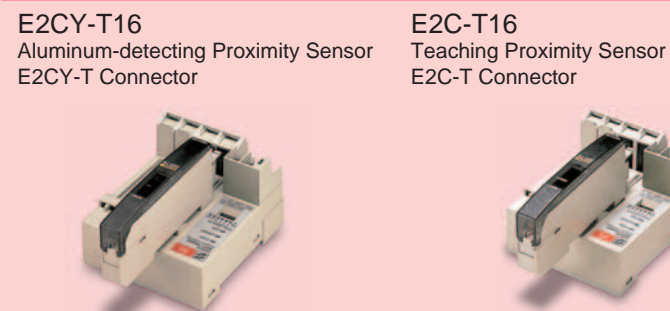

## Slave Units

### Analog Input Terminals



### Remote I/O Modules

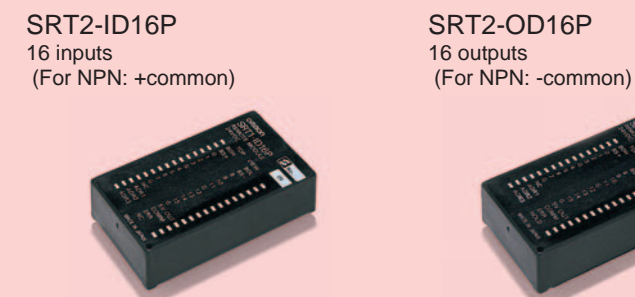

### CompoBus/S Position Driver



## Peripheral Devices

### Connectors

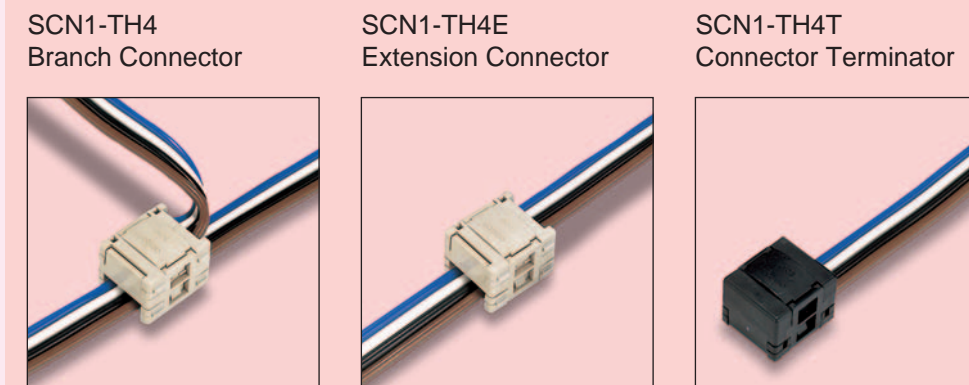

### Flat Cable

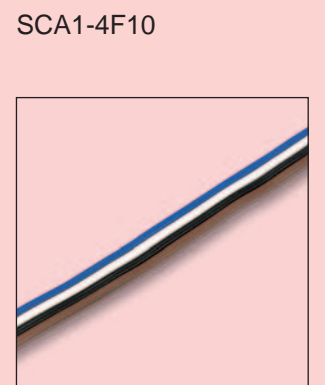

### Terminal Block Terminator

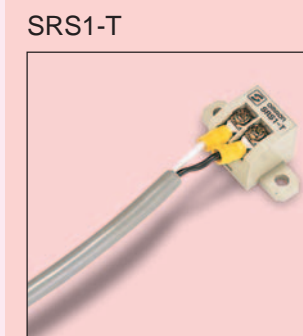

### T-branch Connector (for VCTF Cable)



### Connector Terminator (for 4-conductor VCTF Cable)



## Connections to a Wider Range of Slaves Ensured by Upgraded Models

Master		Conventional models	New models	
		C200HW-SRM21 CQM1-SRM21 SRM1-C01 SRM1-C02 SRM1-C01-V1 SRM1-C02-V1 C200PC-ISA02-SRM C200PC-ISA12-SRM	C200HW-SRM21-V1 CQM1-SRM21-V1 SRM1-C01-V2 SRM1-C02-V2 C200PC-ISA03-SRM C200PC-ISA13-SRM CPM2C-S100C (NEW) CPM2C-S110C (NEW) CPM2C-S100C-DRT (NEW) CPM2C-S110C-DRT (NEW)	Communications mode
Slave		NKE-made Uniwire CompoBus/S Send Unit SDD-CS1	High-speed communications mode	Long-distance communications mode
SRT1 Series FND-X□-SRT		Yes Yes	Yes Yes	No No
Existing product	SRT2-AD04	Yes	Yes	Yes
	SRT2-DA02	Yes	Yes	Yes
	SRT2-V□08S(-1)	Yes	Yes	Yes
	SRT2-□D08S(-1)	Yes	Yes	Yes
	SRT2-□D16ML(-1)	Yes	Yes	Yes
	SRT2-RO□16	Yes	Yes	Yes
	SRT2-V□08S(-1)	Yes	Yes	Yes
	SRT2-□D16(-1)	Yes	Yes	Yes
SRT2-RO□08		Yes	Yes	Yes
CPM2C-SRT21		Yes	Yes	Yes
SRT2-□D32ML(-1)		Yes	Yes	Yes
CPM1A-SRT21		Yes	Yes	Yes
New product	SRT2-ID04CL(-1)	Yes	Yes	Yes
	SRT2-OD04CL(-1)	Yes	Yes	Yes
	SRT2-ID08CL(-1)	Yes	Yes	Yes
	SRT2-OD08CL(-1)	Yes	Yes	Yes
	SRT2-ID08S	Yes	Yes	Yes
	SRT2-ND08S	Yes	Yes	Yes
	SRT2-OD08S	Yes	Yes	Yes
	SRT2-ID16P	Yes	Yes	Yes
	SRT2-OD16P	Yes	Yes	Yes

**Note:** 1. In high-speed communications mode, the maximum transmission distance is 100 m at a baud rate of 750 kbps. In long-distance communications mode (i.e., a newly available mode), the maximum transmission distance is 500 m at a baud rate of 93.75 kbps.  
2. The SRT2-AD04 and SRT2-DA02 are available for 16-bit synchronous communications.

Company	Product	Model number	Communications mode	
			High-speed communications mode	Long-distance communications mode
CKD	Solenoid valve for saving wiring effort	4TB1/2/3/4 Series	Yes	Yes (See note.)
		4G Series	Yes	Yes (See note.)
		MN4SO Series	Yes	Yes (See note.)
	Parect regulator	SDA-C	Yes	Yes
SMC	Solenoid valve for SI manifold use	VQ, SY, SX, SQ, SZ Series	Yes	Yes (See note.)
Koganei	F-series solenoid valve	YS2A1, YS2A2	Yes	Yes
	X80M/X88M Series	YS1A1, YS1A2	Yes	Yes
	JA-series solenoid valve	YS5A1, YS5A2	Yes	Yes
	PA, PB-series solenoid valve	YS4A1, YS4A2	Yes	Yes

**Note:** Refer to the maker for information on long-distance communications mode.

# CompoBus/S Connection Examples

High-speed ON/OFF Bus Communications in Remote I/O Systems

## Cable Connections

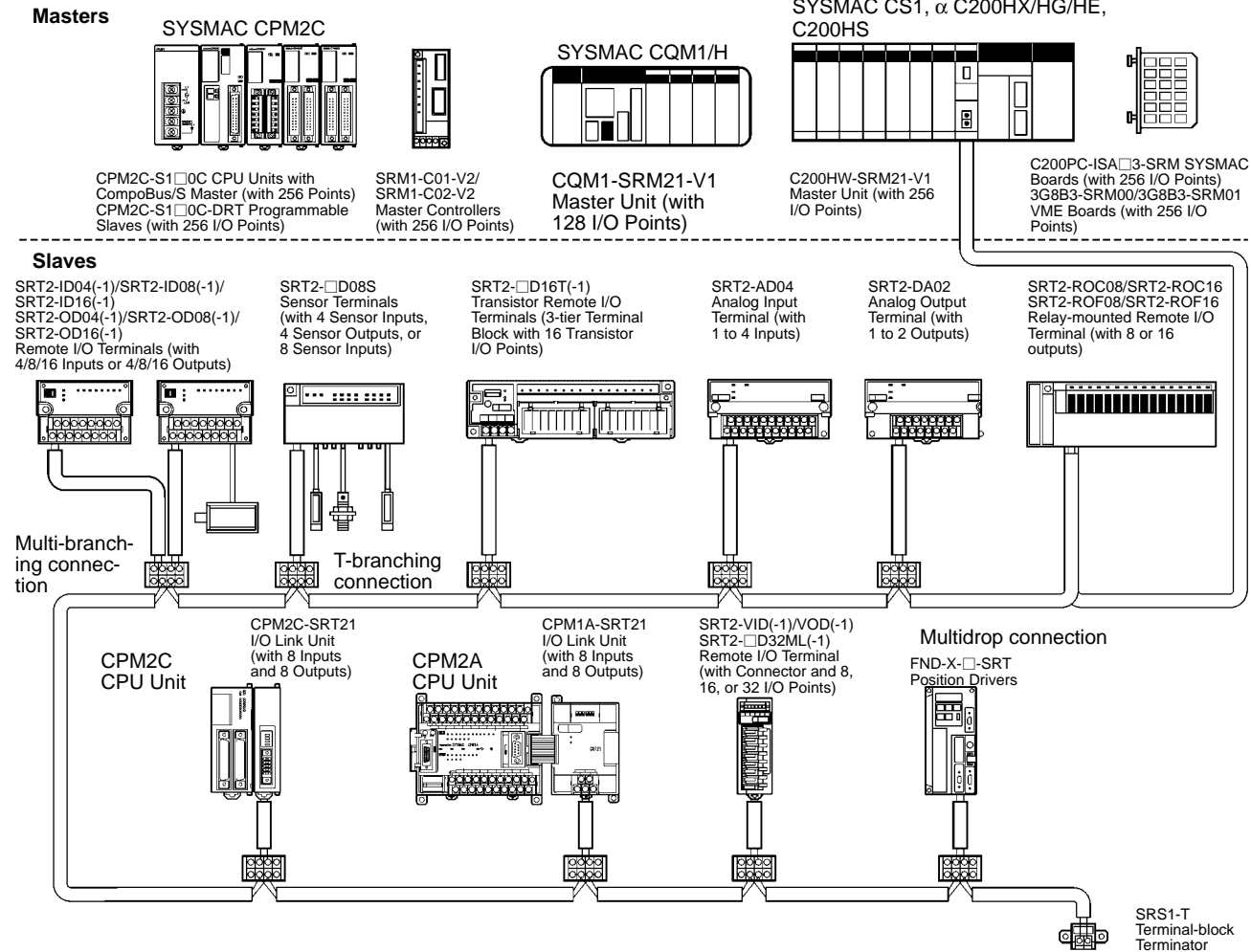

## Special Flat Cable Connection

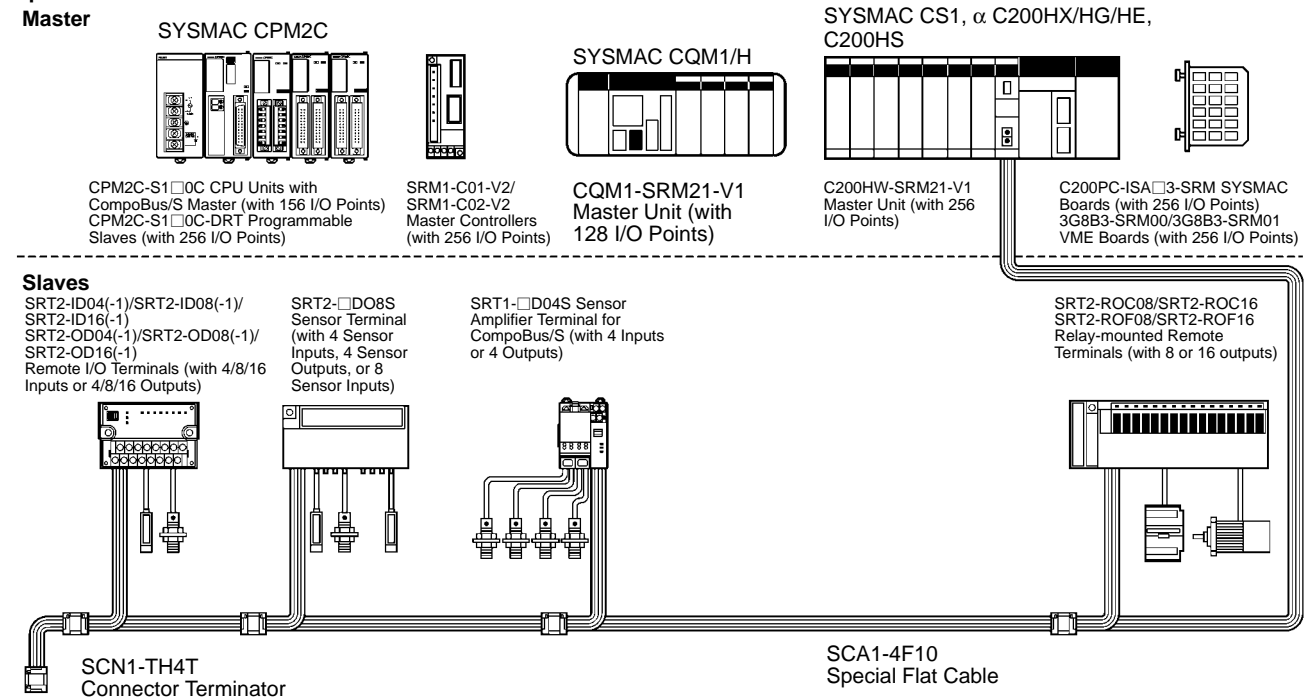

**Note:** Cabtire cable and flat cable cannot be used together.



### Ultra-compact, Thin-profile CPM2C CPU Unit with CompoBus/S Master Offering High-speed Bus Communications with No Complicated Wiring

- Ultra-compact, thin-profile design ideal for on-site applications  
Ultra-compact at 40 x 90 x 65 mm (W x H x D) with 10 I/O points and CompoBus/S Master offers versatile expandability to construct systems meeting on-site needs.
- A large number of expansion I/O points reduces system construction cost.  
Up to three Expansion Terminals can be connected. Furthermore, CompoBus/S Remote Terminals can be used for expansion I/O points. Not only in-panel wiring but also external wiring is simplified. Furthermore, the miniaturization of the control panel reduces cable, terminal block, and wiring costs.
- Easy System Designing, Modification, and Expansion  
CompoBus/S Remote Terminals with high-speed bus communications and no complicated wiring can be used as expansion terminal blocks with minimal modifications as long as room for expansion is reserved at the designing stage.
- A calendar/clock ensures easy machinery control, including data collection and error logs with date and time stamps. This functionality can be used as a weekly timer as well.

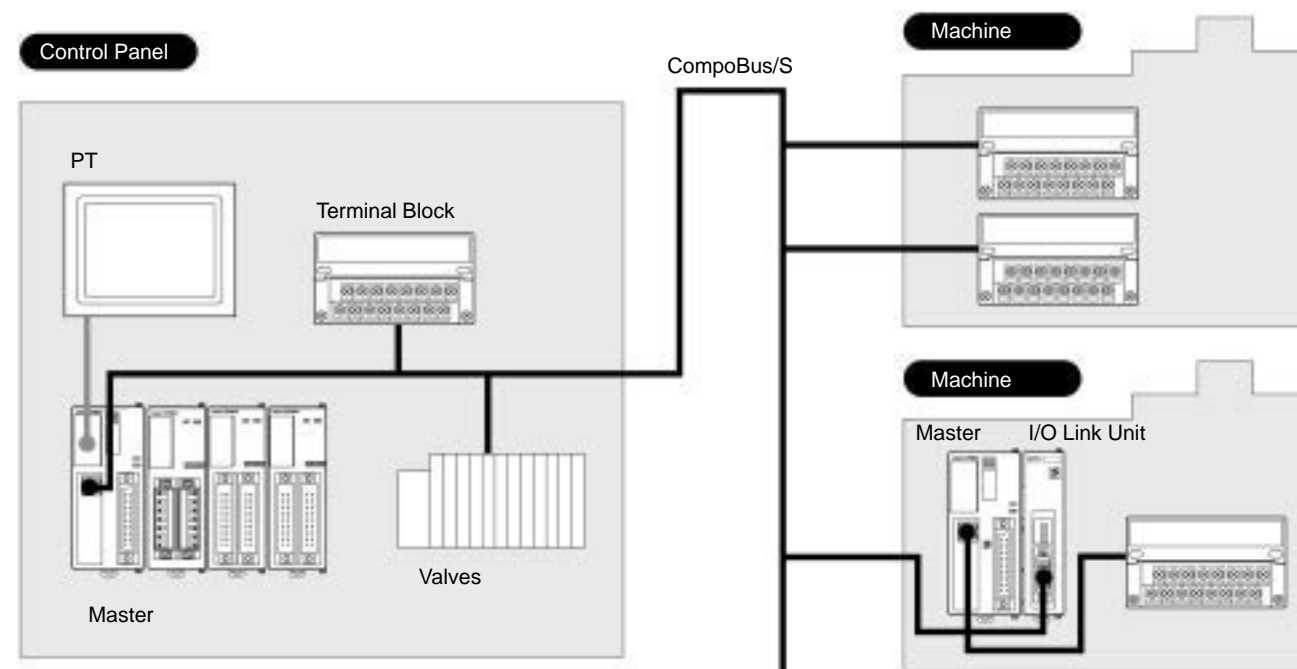

## Ordering Information

Unit		Inputs	Outputs	Clock	Model
10 points (6 inputs/4 outputs)	Connector model	6 points at 24 VDC	4 transistor sinking outputs	Yes	CPM2C-S100C
			4 transistor sourcing outputs	Yes	CPM2C-S110C

## Specifications

### ■ General Specifications

Item		Specification
Control method		Stored program method
I/O control method		Cyclic scan method (Immediate refreshing can be performed with IORF(97).)
Programming language		Ladder diagram
Instruction length		1 step per instruction 1 to 5 words per instruction
Instructions	Basic instructions	14
	Special instructions	105 instructions, 185 variations
Execution time	Basic instructions	0.64 μs (LD instruction)
	Special instructions	7.8 μs (MOV instruction)
Program capacity		4,096 words
Max. I/O capacity		CPU Unit only: 10 points Expansion I/O Unit: 96 points (32-point Expansion I/O Unit x 3) (Up to 3 Expansion Units can be connected.) CompoBus/S: 256 points (362 points in total)
Input bits		IR 00000 to IR 00915 (Bits not used for input bits can be used for work bits.)
Output bits		IR 01000 to IR 01915 (Bits not used for output bits can be used for work bits.)
CompoBus/S input bits		128 bits: IR 02000 to IR 02715 (words IR 020 to IR 027)
CompoBus/S output bits		128 bits: IR 03000 to IR 03715 (words IR 030 to IR 037)
Work bits		672 bits: IR 02800 to IR 02915 (words IR 028 to IR 029) IR 03800 to IR 03915 (words IR 038 to IR 039) IR 04000 to IR 04915 (words IR 040 to IR 049) IR 20000 to IR 22715 (words IR 200 to IR 227)
Special bits (SR area)		440 bits: SR 22800 to SR 25507 (words SR 228 to SR 255)
Temporary bits (TR area)		8 bits: (TR 0 to TR 7)
Holding bits (HR area)		320 bits: HR 0000 to HR 1915 (words HR 00 to HR 19)
Auxiliary bits (AR area)		384 bits: AR 0000 to AR 2315 (words AR 00 to AR 23) These include CompoBus/S slave status flags (words AR 04 to AR 07).
Link bits (LR area)		256 points: LR 0000 to LR 1515 (words LR 00 to LR 15)
Timers/Counters		256 timers/counters: TIM/CNT 000 to TIM/CNT 255 1-ms timers: TMHH (--) 10-ms timers: TIMH (15) 100-ms timers: TIM 1-s/10-s timers: TIML (--) Decrementing counters: CNT Reversible counters: CNTR (12)
Data memory	Read/Write	2,048 words (DM 0000 to DM 2047) The Error Log is contained in DM 2000 to DM 2021.
	Read only	456 words (DM 6144 to DM 6599)
	PC Setup	56 words (DM 6600 to DM 6655)
Basic interrupt functions	Interrupt inputs	2 interrupts (Used for both counter mode interrupts inputs and quick-response inputs.)
	Scheduled interrupts	1 interrupt

Item		Specification
High-speed counter functions	High-speed counters	1 counter (single phase at 20 kHz or 2 phases at 5 kHz)
	Counter interrupts	1 interrupt (set value comparison or set-value range comparison)
	Interrupt inputs (counter mode)	2 interrupts (Used for both external interrupts inputs and quick-response inputs.)
	Count-up interrupts	2 interrupts (Used for both external interrupts inputs and quick-response inputs.)
Quick-response inputs		2 points (Used for both external interrupts inputs and counter mode interrupt inputs.) Min. input pulse width: 50 μs max.
Pulse output		2 points with no acceleration/deceleration, 10 Hz to 10 kHz each, and no direction control: 1 point with trapezoid acceleration/deceleration, 10 Hz to 10 kHz with direction control: or 2 points with variable duty-ratio outputs
Synchronized pulse control		1 point
Input time constant (ON response time = OFF response time)		Can be set for CPU Unit inputs and Expansion Unit inputs only (1, 2, 3, 5, 10, 20, 40, or 80 ms)
Clock		Equipped with clock (built-in RTC)
Communications functions		Peripheral port: Supports Host Link, peripheral bus, no-protocol communications, and Programming Console connections. RS-232C port: Supports Host Link, no-protocol communications, 1-to-1 Link, or 1-to-1 NT Link connections.
Power failure backup function		Data in HR, AR, Counter (CNT), and Data Memory (DM) areas is held.
Memory backup		Non-volatile (flash) memory: Program, read-only DM area, and PC Setup Memory backup (lithium battery: 2 years lifetime): DM area, HR area, AR area, and counter values
Self-diagnostic functions		CPU error (watchdog timer), memory errors, communications errors, setting errors, battery errors, and expansion I/O bus errors
Program check		No END instruction, programming errors (checked when operation is started)
Programming devices	Programming Console	C200H-PRO27, CQM1-PRO01, or CQM1H-PRO01
	SSS	IBM PC/AT or compatible (SYSMAC Support Software version 1.1 or higher)
	CPT	Windows
	CX-P	Windows

**Note:** Connecting Cable (CPM2C-CN111, CS1W-CN114, or CS1W-CN118) is required to connect to the communications peripheral /RS-232C port.



### Multi-functional Slave for Distributed Blocks

An entire installation consisting of sensors and actuators is handled as a DeviceNet slave.

Powerfully supports the device distribution and production of standard units while standardizing programs and decreasing the load on the master. Conventional distributed I/O control networks do not allow I/O checks or operation checks until all devices on the networks are assembled and connected. Programmable Slaves, however, allow I/O and operation checks on any distributed unit independently.



■ **DeviceNet Slave Functions**

Supports multi-word I/O Links and message communications, making it possible for the master to control the data of all the slaves on the network. Data that does not need immediate transmission, such as log data, can be transmitted in blocks using message communications.

■ **CompoBus/S Master Functions**

Connects to remote signal lights, pushbutton switches, terminal blocks, and pneumatic valves from other companies over VCTF or easy-to-branch flat cable.

■ **RS-232C Communications**

Connects to the BCRs and PTs to process data, alleviating the load on the master.

■ **Expansion Unit (Up to Three Units)**

A single node is used to control distributed blocks and decrease the size of the communications block in multi-point operation, thus making the cost reduction of the system possible.

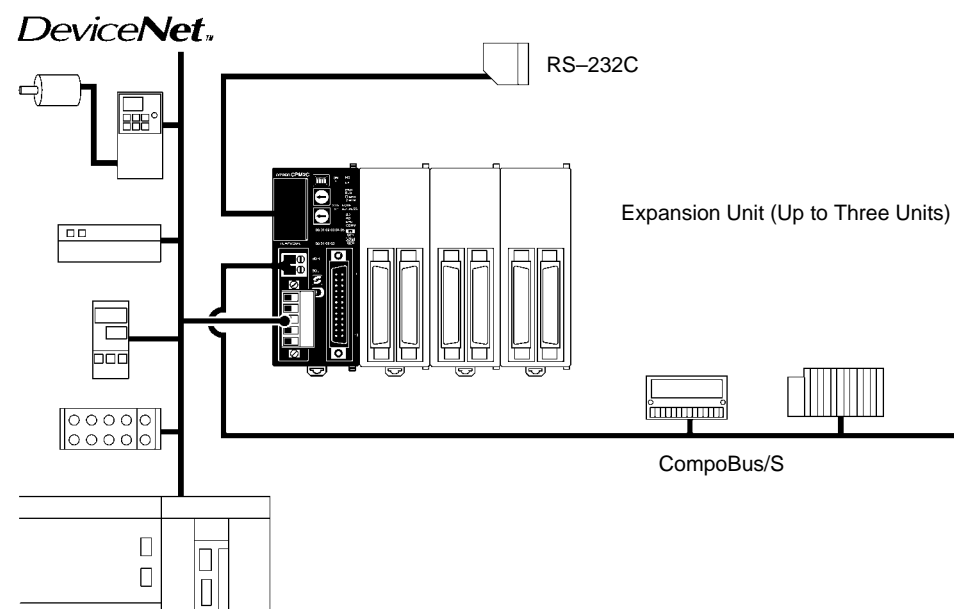

### Ordering Information

Unit	Inputs	Outputs	Clock	Model	
10 points (6 inputs/4 outputs)	Connector model	6 points at 24 VDC	4 transistor sinking outputs	Yes	CPM2C-S100C-DRT
			4 transistor sourcing outputs	Yes	CPM2C-S110C-DRT

# Specifications

## ■ General Specifications

Item		Specification
Control method		Stored program method
I/O control method		Cyclic scan method (Immediate refreshing can be performed with IORF(97).)
Programming language		Ladder diagram
Instruction length		1 step per instruction 1 to 5 words per instruction
Instructions	Basic instructions	14
	Special instructions	105 instructions, 185 variations
Execution time	Basic instructions	0.64 μs (LD instruction)
	Special instructions	7.8 μs (MOV instruction)
Program capacity		4,096 words
Max. I/O capacity		CPU Unit only: 10 points Expansion I/O Unit: 96 points (32-point Expansion I/O Unit x 3) (Up to 3 Expansion Units can be connected.) CompoBus/S: 256 points (362 points in total)
Input bits		IR 00000 to IR 00915 (Bits not used for input bits can be used for work bits.)
Output bits		IR 01000 to IR 01915 (Bits not used for output bits can be used for work bits.)
CompoBus/S input bits		128 bits: IR 02000 to IR 02715 (words IR 020 to IR 027)
CompoBus/S output bits		128 bits: IR 03000 to IR 03715 (words IR 030 to IR 037)
Work bits		672 bits: IR 02800 to IR 02915 (words IR 028 to IR 029) IR 03800 to IR 03915 (words IR 038 to IR 039) IR 04000 to IR 04915 (words IR 040 to IR 049) IR 20000 to IR 22715 (words IR 200 to IR 227)
Special bits (SR area)		440 bits: SR 22800 to SR 25507 (words SR 228 to SR 255)
Temporary bits (TR area)		8 bits: (TR 0 to TR 7)
Holding bits (HR area)		320 bits: HR 0000 to HR 1915 (words HR 00 to HR 19)
Auxiliary bits (AR area)		384 bits: AR 0000 to AR 2315 (words AR 00 to AR 23) These include CompoBus/S slave status flags (words AR 04 to AR 07).
Link bits (LR area)		256 points: LR 0000 to LR 1515 (words LR 00 to LR 15)
Timers/Counters		256 timers/counters: TIM/CNT 000 to TIM/CNT 255 1-ms timers: TMHH (--) 10-ms timers: TIMH (15) 100-ms timers: TIM 1-s/10-s timers: TIML (--) Decrementing counters: CNT Reversible counters: CNTR (12)
Data memory	Read/Write	2,048 words (DM 0000 to DM 2047) The Error Log is contained in DM 2000 to DM 2021.
	Read only	456 words (DM 6144 to DM 6599)
	PC Setup	56 words (DM 6600 to DM 6655)
DeviceNet slave functions		DeviceNet Remote I/O Link No. of I/O Link points: 1,024 max. Explicit message communications Any PC data area can be accessed from the master.
Basic interrupt functions	Interrupt inputs	2 interrupts (Used for both counter mode interrupts inputs and quick-response inputs.)
	Scheduled interrupts	1 interrupt

Item		Specification
High-speed counter functions	High-speed counters	1 counter (single phase at 20 kHz or 2 phases at 5 kHz)
	Counter interrupts	1 interrupt (set value comparison or set-value range comparison)
	Interrupt inputs (counter mode)	2 interrupts (Used for both external interrupts inputs and quick-response inputs.)
	Count-up interrupts	2 interrupts (Used for both external interrupts inputs and quick-response inputs.)
Quick-response inputs		2 points (Used for both external interrupts inputs and counter mode interrupt inputs.) Min. input pulse width: 50 μs max.
Pulse output		2 points with no acceleration/deceleration, 10 Hz to 10 kHz each, and no direction control: 1 point with trapezoid acceleration/deceleration, 10 Hz and 10 kHz with no direction control: or 2 points with variable duty-ratio outputs
Synchronized pulse control		1 point
Input time constant (ON response time = OFF response time)		Can be set for CPU Unit inputs and Expansion Unit inputs only (1, 2, 3, 5, 10, 20, 40, or 80 ms)
Clock		Equipped with clock (built-in RTC)
Communications functions		Peripheral port: Supports Host Link, peripheral bus, no-protocol communications, and Programming Console connections. RS-232C port: Supports Host Link, no-protocol communications, 1-to-1 Link, or 1-to-1 NT Link connections.
Power failure backup function		Data in HR, AR, Counter (CNT), and Data Memory (DM) areas is held.
Memory backup		Non-volatile (flash) memory: Program, read-only DM area, and PC Setup Memory backup (lithium battery: 2 years lifetime): DM area, HR area, AR area, and counter values
Self-diagnostic functions		CPU error (watchdog timer), memory errors, communications errors, setting errors, battery errors, and expansion I/O bus errors
Program check		No END instruction, programming errors (checked when operation is started)
Programming devices	Programming Console	C200H-PRO27, CQM1-PRO01, or CQM1H-PRO01
	SSS	IBM PC/AT or compatible (SYSMAC Support Software version 1.1 or higher)
	CPT	Windows
	CX-P	Windows

**Note:** Connecting Cable (CPM2C-CN111, CS1W-CN114, or CS1W-CN118) is required to connect to the communications peripheral /RS-232C port.

## ■ Communications Specifications

### DeviceNet

<b>Communications protocol</b>		DeviceNet
<b>Connection form</b>		Combination of multi-drop and T-branch connections (see note 1)
<b>Baud rate</b>		500, 250, or 125 kbps (switchable)
<b>Communications media</b>		Special 5-conductor cable (2 signal lines, 2 power supply lines, and 1 shield line)
<b>Communications distance</b>	<b>Baud rate</b>	500 kbps: Max. network length (see note 2): 100 m max. (see note 3) Main line length: 6 m max. Total branch line length: 39 m max.
		250 kbps: Max. network length (see note 2): 250 m max. (see note 3) Main line length: 6 m max. Total branch line length: 78 m max.
		125 kbps: Max. network length (see note 2): 500 m max. (see note 3) Main line length: 6 m max. Total branch line length: 156 m max.
<b>Max. number of connecting nodes</b>		64 (63 slaves and 1 master)
<b>Error control checks</b>		CRC error, node address duplication check, and scan list verification

**Note:** 1. A terminator must be connected to the point in the system farthest from the Master.  
2. The maximum network length is the distance from the master to the farthest node.

3. When Thin Cable is used for the main line, the main line must be 100 m or less in length.

**CompoBus/S**

<b>Communications method</b>		Special CompoBus/S protocol
<b>Coding method</b>		Manchester coding
<b>Connection form</b>		Combination of multi-drop method and T-branch connections (see note 1)
<b>Baud rate</b>		High-speed Communications Mode: 750 kbps Long-distance Communications Mode: 93.75 kbps (see note 2)
<b>Communications cycle time</b>	<b>High-speed Communications Mode</b>	0.5 ms (with 8 input and 8 output slaves connected)
		0.8 ms (with 16 input and 16 output slaves connected)
	<b>Long-distance Communications Mode</b>	4.0 ms (with 8 input and 8 output slaves connected)
		6.0 ms (with 16 input and 16 output slaves connected)
<b>Communications media</b>		2-conductor cable (VCTF 0.75 x 2), 4-conductor cable (VCTF 0.75 x 4), or Special Flat Cable
<b>Communications distance</b>	<b>High-speed Communications Mode</b>	2-conductor VCTF cable: Main line length: 100 m max. Branch line length: 3 m max. Total branch line length: 50 m max.  Special Flat Cable, 4-conductor VCTF cable: Main line length: 30 m max. Branch line length: 3 m max. Total branch line length: 30 m max. (When Special Flat Cable is used to connect fewer than 16 Slaves, the main line can be up to 100 m long and the total branch line length can be up to 50 m.)
	<b>Long-distance Communications Mode</b>	2-conductor VCTF cable: Main line length: 500 m max. Branch line length: 6 m max. Total branch line length: 120 m max.  Special Flat Cable, 4-conductor VCTF cable: Variable branch wiring (total cable length 200 m max.) (There are no limits on the branching format or main, branch, or total line lengths. The terminator must be connected to the point in the system farthest from the master.)
<b>Maximum number of nodes</b>		32
<b>Error control checks</b>		Manchester code check, frame length check, and parity check

**Note:** 1. A terminator must be connected to the point in the system farthest from the Master.  
2. The baud rate is switched using DM settings (default setting is 750 kbps).

**Dimensions**

**Note:** All units are in millimeters unless otherwise indicated.

**CPM2C-S100C-DRT**  
**CPM2C-S110C-DRT**

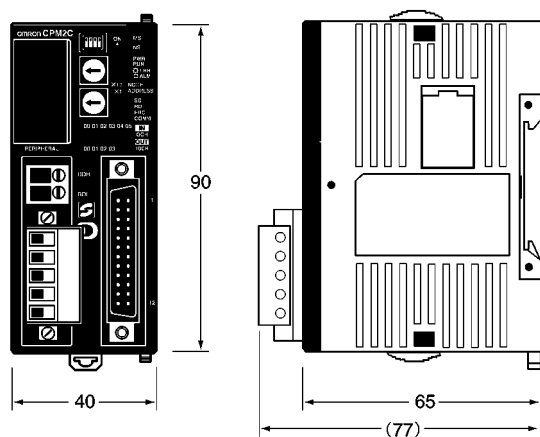

**Note:** Refer to *CPM2C-S Programmable Controller Operation Manual (W377)* for detailed specifications.



#### Subminiature, Stand-alone Model with CompoBus/S Master and SYSMAC Controller Functions

- Maximum number of Remote I/O points per Master: 256
- Maximum number of Slaves per Master: 32
- Communications cycle time: 0.5 ms max. (at baud rate 750 kbps).
- Communications distance: Extended to 500 m max. (at baud rate 93.75 kbps).
- Additional instructions (PID, SCL, NEG, ZCP) ensure analog compatibility.
- RS-232C port incorporated (SRM1-C02-V2).



#### Ordering Information

Specifications		Model
Built-in stand-alone controller functions	Without RS-232C	SRM1-C01-V2
	With RS-232C	SRM1-C02-V2

#### Specifications

##### ■ Master Specifications

Number of I/O points	256 points (128 inputs/128 outputs) 128 points (64 inputs/64 outputs) Selectable by DM setting. The default setting is 256 points.
Max. number of Slaves per Master	256 points: 32 128 points: 16
I/O words	Input words: 000 to 007 Output words: 010 to 017
Programming language	Ladder diagram
Types of instruction	14 basic and 81 special instructions (125 instructions in total)
Execution time	LD instruction: 0.97 μs MOV instruction: 9.1 μs
Program capacity	4,096 words
Data memory	2,022 + 512 (read-only) words
Timers/Counters	128 timers/counters
Work bits	640 bits
Memory backup	Flash memory (without battery): User programs Lithium battery: Data memory etc. (Battery life: 10 years min. at an ambient temperature of 25°C.)
Peripheral port	1 point
RS-232C port	1 point (SRM1-C02 only) Host Link, NT Link, 1:1 Link, or no protocol
Programming tool	Programming Consoles: CQM1-PRO01-E, C200H-PRO27-E CX-Programmer (Supported for versions 2 or later.) WS02-CXP1-E SYSMAC Support Software (MS-DOS version): C500-ZL3AT1-E

■ Communications Specifications

<b>Communications method</b>		CompoBus/S protocol
<b>Coding method</b>		Manchester coding method
<b>Connection method</b>		Multi-drop method and T-branch method (see note 1)
<b>Communications baud rate</b>		750,000 bps/93,750 bps (see note 2)
<b>Communications cycle time</b>	<b>High-speed communications mode</b>	0.5 ms with 8 Slaves for inputs and 8 Slaves for outputs
		0.8 ms with 16 Slaves for inputs and 16 Slaves for outputs
	<b>Long-distance communications mode</b>	4.0 ms with 8 Slaves for inputs and 8 Slaves for outputs
		6.0 ms with 16 Slaves for inputs and 16 Slaves for outputs
<b>Communications cable</b>		2-conductor VCTF cable (0.75 x 2), 4-conductor VCTF cable (0.75 x 4) Dedicated flat cable
<b>Communications distance</b>	<b>High-speed communications mode</b>	2-conductor VCTF cable: Main line length: 100 m max. Branch line length: 3 m max. Total branch line length: 50 m max.  Flat cable, 4-conductor VCTF cable: Main line length: 30 m max. Branch line length: 3 m max. Total branch line length: 30 m max. (When flat cable is used to connect fewer than 16 Slaves, the main line can be up to 100 m long and the total branch line length can be up to 50 m.)
	<b>Long-distance communications mode</b>	2-conductor VCTF cable: Main line length: 500 m max. Branch line length: 6 m max. Total branch line length: 120 m max.  Flat cable, 4-conductor VCTF cable: Variable branch wiring (total cable length 200 m max.) (There are no limits on the branching format or main, branch, or total line lengths. The terminator must be connected to the point in the system farthest from the master.)
<b>Max. number of connecting nodes</b>		32
<b>Error control checks</b>		Manchester code check, frame length check, and parity check

**Note:** 1. A terminator must be connected to the point in the system farthest from the Master.  
2. The communications baud rate is switched using DM settings (default setting is 750,000 bps).

■ General Specifications

<b>Supply voltage</b>	24 VDC
<b>Allowable supply voltage</b>	20.4 to 26.4 VDC
<b>Power consumption</b>	3.5 W max.
<b>Inrush current</b>	12.0 A max.
<b>Noise immunity</b>	Conforms to IEC61000-4-4, 2 kV (power lines)
<b>Vibration resistance</b>	10 to 57 Hz, 0.075-mm amplitude, 57 to 150 Hz, acceleration: 9.8 m/s <sup>2</sup> in X, Y, and Z directions for 80 minutes each (Time coefficient; 8 minutes × coefficient factor 10 = total time 80 minutes)
<b>Shock resistance</b>	147 m/s <sup>2</sup> three times each in X, Y, and Z directions
<b>Ambient temperature</b>	Operating: 0°C to 55°C Storage: -20°C to 75°C
<b>Humidity</b>	10% to 90% (with no condensation)
<b>Atmosphere</b>	Must be free from corrosive gas.
<b>Terminal screw size</b>	M3
<b>Power interrupt time</b>	DC type: 2 ms min.
<b>Weight</b>	150 g max.

## Nomenclature

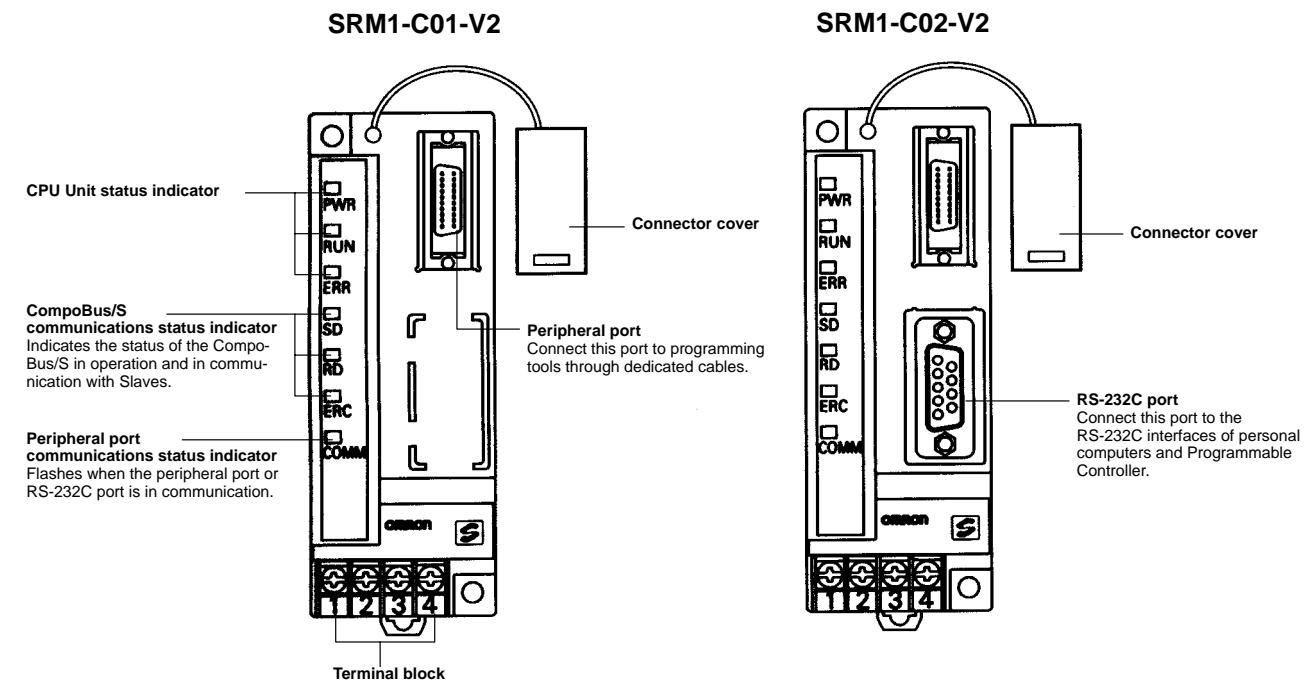

## Dimensions

**Note:** All units are in millimeters unless otherwise indicated.

### SRM1-C01/C02-V2

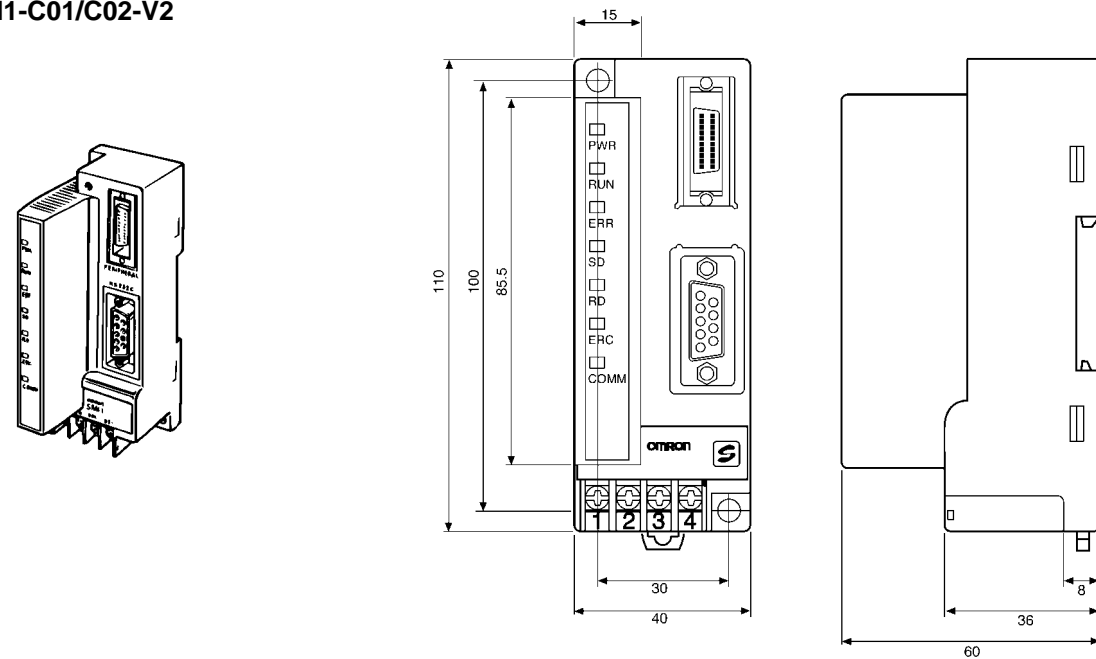

The above dimensions apply to the SRM1-C02-V2. The SRM1-C01-V2 has no RS-232C port.

## Precautions

For details on safety precautions, refer to the *CompoBus/S Master Control Units Operation Manual* (W318).

## Master Unit

C200HW-SRM21-V1

### Master Unit for CS1, C200HX, C200HG, C200HE, and C200HS

- A maximum of 256 I/O points available.
- Connects to a maximum of 32 Slaves.
- Communications cycle time: 0.5 ms max. (at baud rate 750 kbps).
- Communications distance: Extended to 500 m max. (at baud rate 93.75 kbps).
- Connection to Analog Terminals now supported.



## Ordering Information

PC	Max. number of I/O points	Model
C200HX (-Z), C200HG (-Z), C200HE (-Z), C200HS, CS1	256 points (128 inputs/128 outputs)	C200HW-SRM21-V1

## Specifications

### ■ Communications Specifications

Communications method		CompoBus/S protocol
Coding method		Manchester coding method
Connection method		Multi-drop method and T-branch method (see note 1)
Communications baud rate		750,000 bps, 93,750 bps (see note 2)
Communications cycle time	High-speed communications mode	0.5 ms with 8 Slaves for inputs and 8 Slaves for outputs
		0.8 ms with 16 Slaves for inputs and 16 Slaves for outputs
	Long-distance communications mode	4.0 ms with 8 Slaves for inputs and 8 Slaves for outputs
		6.0 ms with 16 Slaves for inputs and 16 Slaves for outputs
Communications cable		2-conductor VCTF cable (0.75 x 2), 4-conductor VCTF cable (0.75 x 4) Special Flat Cable
Communications distance	High-speed communications mode	2-conductor VCTF cable: Main line length: 100 m max. Branch line length: 3 m max. Total branch line length: 50 m max.  Special Flat Cable, 4-conductor VCTF cable: Main line length: 30 m max. Branch line length: 3 m max. Total branch line length: 30 m max. (When Special Flat Cable is used to connect fewer than 16 Slaves, the main line can be up to 100 m long and the total branch line length can be up to 50 m.)
	Long-distance communications mode	2-conductor VCTF cable: Main line length: 500 m max. Branch line length: 6 m max. Total branch line length: 120 m max.  Special Flat Cable, 4-conductor VCTF cable: Variable branch wiring (total cable length 200 m max.) (There are no limits on the branching format or main, branch, or total line lengths. The terminator must be connected to the point in the system farthest from the master.)
Max. number of connecting nodes		32
Error control checks		Manchester code check, frame length check, and parity check

- Note:**
1. A terminator must be connected to the point in the system farthest from the Master.
  2. The communications baud rate is switched with the DIP switch.

### ■ Unit Specifications

<b>Current consumption</b>		150 mA max. at 5 VDC
<b>Number of I/O points</b>		256 points (128 inputs/128 outputs), 128 points (64 inputs/64 outputs) (switchable)
<b>Number of occupied words</b>		256 points: 20 words (8 input words/8 output words, 4 status data) 128 points: 10 words (4 input words/4 output words, 2 status data)
<b>PLC</b>		CS1, C200HX (-ZE), C200HG (-ZE), C200HE (-ZE), C200HS
<b>Number of Master Units mountable</b>	<b>C200HE</b>	128 points: 10, 256 points: 5
	<b>C200HG-CPU33/43</b>	128 points: 10, 256 points: 5
	<b>C200HG-CPU53/63</b>	128 points: 16, 256 points: 8
	<b>C200HX-CPU34/44</b>	128 points: 10, 256 points: 5
	<b>C200HX-CPU54/64</b>	128 points: 16, 256 points: 8
	<b>C200HS</b>	128 points: 10, 256 points: 5
	<b>CS1</b>	128 points: 16, 256 points: 8
<b>Number of points per node number</b>		8 points
<b>Max. number of Slaves per Master</b>		32
<b>Status data</b>		Communications Error Flag and Active Slave Node (see note)
<b>Weight</b>		200 g max.
<b>Approved standards</b>		UL 508 (E95399), CSA C22.2 No. 142 (LR51460)

**Note:** These flags use the AR area.

### ■ Ratings

The ratings of the Unit are the same as those of the CS1, C200HX, C200HG, C200HE, and C200HS.

## Nomenclature

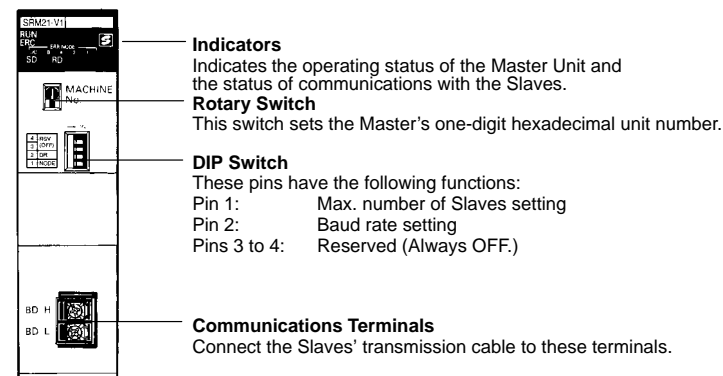

## Dimensions

**Note:** All units are in millimeters unless otherwise indicated.

C200HW-SRM21-V1

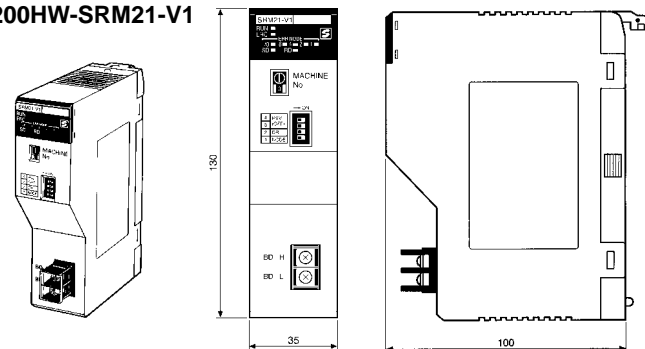

**Note:** Refer to the *C200HX, C200HG, C200HE, C200HS, or CS1 Operation Manual* for details on the dimensions when the Master Unit is installed in the PC's Backplane.

## Precautions

Refer to the *CompoBus/S Operation Manual (W266-E1)* before using the Unit.

#### Master Unit for CQM1/CQM1H

- A maximum of 128 I/O points available (Possible to set 32, 64, or 128 I/O points).
- Connects to a maximum of 16/32 Slaves.
- Communications cycle time: 0.5 ms max. (at baud rate 750 kbps).
- Communications distance: Extended to 500 m max. (at baud rate 93.75 kbps).
- Connection to Analog Terminals now supported.



#### Ordering Information

PLC	Max. number of I/O points	Model
CQM1-series PLC	128 points (64 inputs/64 outputs)	CQM1-SRM21-V1

#### Specifications

##### ■ Communications Specifications

<b>Communications method</b>		CompoBus/S protocol
<b>Coding method</b>		Manchester coding method
<b>Connection method</b>		Multi-drop method and T-branch method (see note 1)
<b>Communications baud rate</b>		750,000 bps, 93,750 bps (see note 2)
<b>Communications cycle time</b>	<b>High-speed communications mode</b>	0.5 ms with 8 Slaves for inputs and 8 Slaves for outputs
		0.8 ms with 16 Slaves for inputs and 16 Slaves for outputs
	<b>Long-distance communications mode</b>	4.0 ms with 8 Slaves for inputs and 8 Slaves for outputs
		6.0 ms with 16 Slaves for inputs and 16 Slaves for outputs
<b>Communications cable</b>		2-conductor VCTF cable (0.75 x 2), 4-conductor VCTF cable (0.75 x 4) Special Flat Cable
<b>Communications distance</b>	<b>High-speed communications mode</b>	2-conductor VCTF cable: Main line length: 100 m max. Branch line length: 3 m max. Total branch line length: 50 m max.  Special Flat Cable, 4-conductor VCTF cable: Main line length: 30 m max. Branch line length: 3 m max. Total branch line length: 30 m max. (When Special Flat Cable is used to connect fewer than 16 Slaves, the main line can be up to 100 m long and the total branch line length can be up to 50 m.)
	<b>Long-distance communications mode</b>	2-conductor VCTF cable: Main line length: 500 m max. Branch line length: 6 m max. Total branch line length: 120 m max.  Special Flat Cable, 4-conductor VCTF cable: Variable branch wiring (total cable length 200 m max.) (There are no limits on the branching format or main, branch, or total line lengths. The terminator must be connected to the point in the system farthest from the master.)
<b>Max. number of connecting nodes</b>		32
<b>Error control checks</b>		Manchester code check, frame length check, and parity check

- Note:**
1. A terminator must be connected to the point in the system farthest from the Master.
  2. The communications baud rate is switched with the DIP switch.

■ Unit Specifications

Current consumption	180 mA max. at 5 VDC
Number of I/O points	128 points (64 inputs/64 outputs), 64 points (32 inputs/32 outputs), 32 points (16 inputs/16 outputs) (switchable)
Number of occupied words	128 points: 4 input words/4 output words 64 points: 2 input words/2 output words 32 points: 1 input word/1 output word
PC	128 points: CQM1-CPU41-EV1/CPU42-EV1/CPU43-EV1/CPU44-EV1 64 points: CQM1-CPU11-E/CPU21-E/CPU41-EV1/CPU42-EV1/CPU43-EV1/CPU44-EV1 32 points: CQM1-CPU11-E/CPU21-E/CPU41-EV1/CPU42-EV1/CPU43-EV1/CPU44-EV1
Number of points per node number	4/8 points (switchable)
Max. number of Slaves per Master	32 (4 points per node number)
Status data	Alarm terminal output
Weight	200 g max.
Approved standards	UL 508 (E95399), CSA C22.2 No. 142 (LR51460)

■ Alarm Output Specifications

Maximum switching capacity	2 A at 24 VDC
Minimum switching capacity	10 mA at 5 VDC
Relay	G6D-1A
Minimum ON time	100 ms
Circuit configuration	

■ Ratings

The ratings of the Unit are the same as those for the CQM1.

Nomenclature

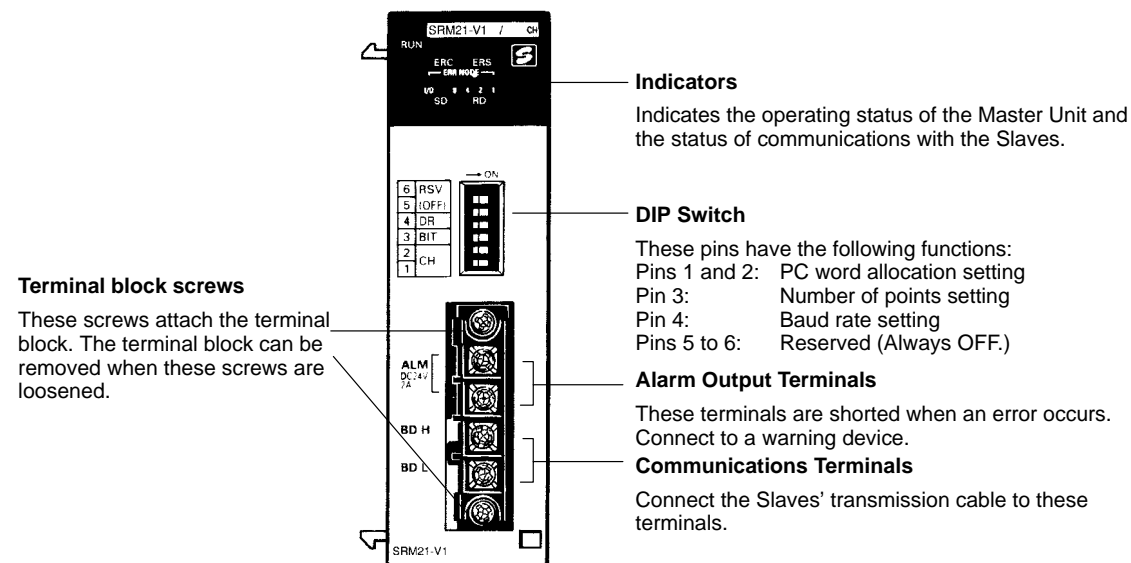

## Dimensions

**Note:** All units are in millimeters unless otherwise indicated.

### CQM1-SRM21-V1

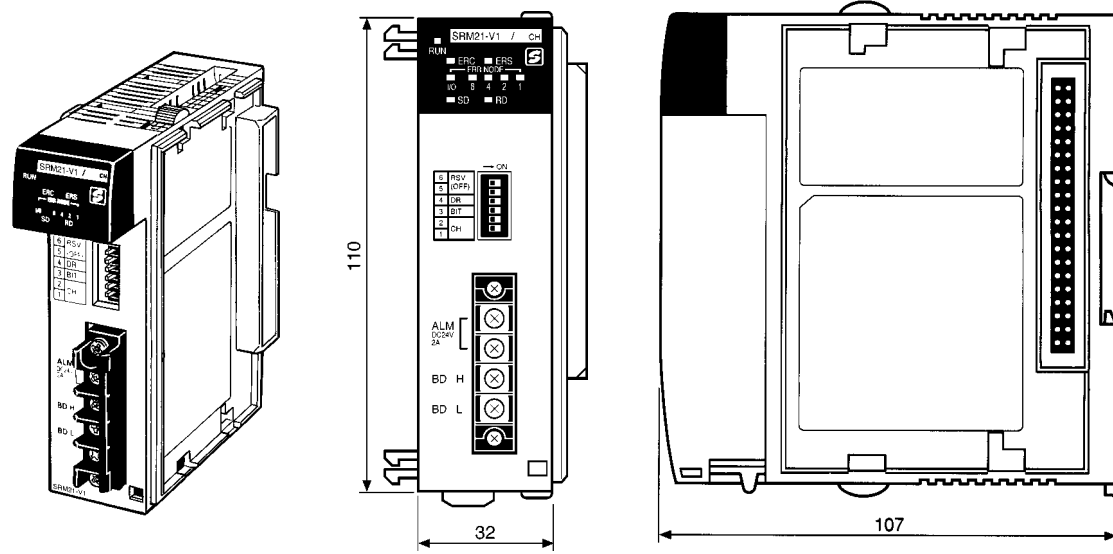

**Note:** Refer to the *CQM1 Operation Manual* for details on the dimensions when the Master Unit is installed in the PC's Backplane.

## Precautions

Refer to the *CompoBus/S Operation Manual (W266-E1)* before using the Unit.



## SYSMAC Boards with CompoBus/S Master

C200PC-ISA□3-SRM

### Intelligent Computer Board that Integrates SYSMAC C200HX/HG/HE and CompoBus/S Master Functions Equipped with Backup Power Supply System

- Can be mounted to an ISA bus, the standard bus for IBM compatible computers, thus contributing to the downsizing of installations using computers.
- Communications between the SYSMAC Board and the computer are performed via an ISA bus, enabling a communications speed much higher than with RS-232C communications.
- Incorporates CompoBus/S communications functions. Simply connect a CompoBus/S Slave to enable distributed control of I/O in remote locations.
- A power supply sub-board is also available. This makes it possible to provide power externally, and allows control to be continued even when the computer power supply is interrupted.

- Data settings at CompoBus/S Slaves are reflected automatically.
- Enables communications at a maximum distance of 500 m (at a baud rate of 93.75 kbps).
- Conforms to EC Directives.



### Ordering Information

PLC	Max. number of I/O points	Model
C200HG-CPU43	256 points (128 inputs/128 outputs)	C200PC-ISA03-SRM
C200HX-CPU64		C200PC-ISA13-SRM

## Specifications

### ■ Communications Specifications

<b>Communications method</b>		CompoBus/S protocol
<b>Coding method</b>		Manchester coding method
<b>Connection method</b>		Multi-drop method and T-branch method (see note)
<b>Communications baud rate</b>		750,000 bps, 93,750 bps
<b>Communications cycle time</b>		0.5 ms with 8 Slaves for inputs and 8 Slaves for outputs 0.8 ms with 16 Slaves for inputs and 16 Slaves for outputs
<b>Communications cable</b>		2-conductor VCTF cable (0.75 x 2), 4-conductor VCTF cable (0.75 x 4) Special Flat Cable
<b>Communications distance</b>	<b>High-speed communications mode</b>	2-conductor VCTF cable: Main line length: 100 m max. Branch line length: 3 m max. Total branch line length: 50 m max.  Special Flat Cable, 4-conductor VCTF cable: Main line length: 30 m max. Branch line length: 3 m max. Total branch line length: 30 m max. (When Special Flat Cable is used to connect fewer than 16 Slaves, the main line can be up to 100 m long and the total branch line length can be up to 50 m.)
	<b>Long-distance communications mode</b>	2-conductor VCTF cable: Main line length: 500 m max. Branch line length: 6 m max. Total branch line length: 120 m max.  Special Flat Cable, 4-conductor VCTF cable: Variable branch wiring (total cable length 200 m max.) (There are no limits on the branching format or main, branch, or total line lengths. The terminator must be connected to the point in the system farthest from the master.)
<b>Max. number of connecting nodes</b>		32
<b>Error control checks</b>		Manchester code check, frame length check, and parity check

**Note:** A terminator must be connected to the point in the system farthest from the Master.

### ■ Unit Specifications

<b>Power supply voltage</b>	4.875 to 5.25 VDC
<b>Current consumption</b>	0.5 A max. (see note 1)
<b>Number of I/O points</b>	256 points (128 inputs/128 outputs), 128 points (64 inputs/64 outputs), (switchable)
<b>Number of occupied words</b>	256 points: 20 words (8 input words, 8 output words, and 4 status data words) (see note 2) 128 points: 10 words (4 input words, 4 output words, and 2 status data words)
<b>Number of points per node number</b>	8 points
<b>Max. number of Slaves per Master</b>	32
<b>Status data</b>	Communications Error Flag and Active Slave Node (see note 2)
<b>Weight</b>	350 g max.

**Note:** 1. The current consumption will be 0.8 A max. if the Programming Console is connected through the optional Expansion Board.  
2. The occupied words are in the IR area.

## I/O Link Unit

CPM2C-SRT21

### I/O Link Unit for CPM2C

- Operates as a Slave of the CompoBus/S Master Unit.
- Exchanges eight inputs and eight outputs with the Master.
- Bears the CE marking.



### Ordering Information

#### CompoBus I/O Link Unit

Name	Specifications	Model
CompoBus/S I/O Link Unit	Number of points for I/O links: 8 inputs and 8 outputs	CPM2C-SRT21

### Application Examples

#### ■ Conveyor Line

Processing speed can be increased and system setup labor reduced by creating a distributed system with a CPM2C at each conveyor.

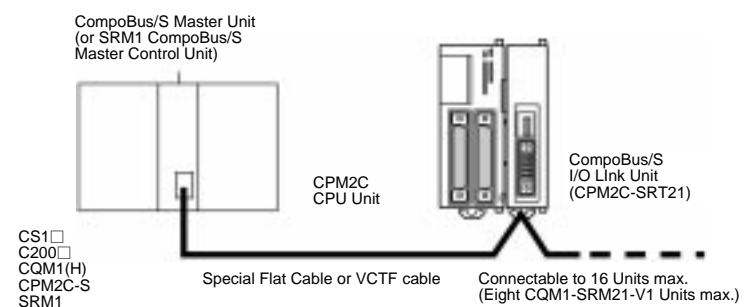

### Specifications

Item	CPM2C-SRT21
Master/Slave	CompoBus/S Slave
Number of I/O points	8 inputs and 8 outputs
Number of words occupied in CPM2C's I/O memory	1 input word and 1 output word (allocated in the same way as for other Expansion Units)
Node address setting	DIP switch
Power consumption	1 W
Weight	150 g

**Note:** For details of CPM2C PLCs, refer to the CPM2C catalog (Cat. No. P049).

## Dimensions

### CPM2C-SRT21

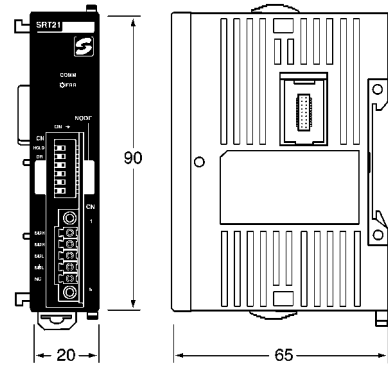

## Installation

### ■ Number of I/O Units Connectable

Up to 5 Expansion Units can be connected to CPM2C PLCs. There are, however, only 9 input words and 9 output words that can be allocated to Expansion I/O Units: words IR 001 to IR 009 for inputs (the CPU Unit's inputs are allocated to IR 001) and words IR 011 to IR 019 for outputs (the CPU Unit's outputs are allocated to IR 010). Use Expansion I/O Units within these ranges. I/O words are allocated from the leftmost Unit.

#### Example

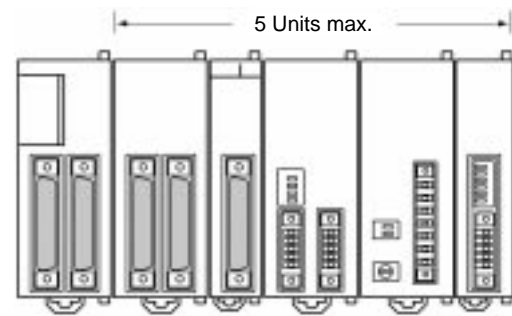

CPU Unit

## I/O Link Unit

CPM1A-SRT21

### I/O Link Unit for CPM2A/CPM1A

- Operates as a Slave of the CompoBus/S Master Unit.
- Exchanges eight inputs and eight outputs with the Master.
- Approved by UL and CSA standards, and bears the CE marking.



## Specifications

Master/Slave	CompoBus/S Slave
Number of I/O points	8 inputs and 8 outputs
Number of words occupied in CPM2A's I/O memory	1 input word and 1 output word (allocated in the same way as for other Expansion Units)
Node address setting	DIP switch

**Note:** For details of CPM1A PLCs, refer to the CPM1A catalog (Cat. No. P039). For details of CPM2A PLCs, refer to the CPM2A catalog (Cat. No. P049).

## Dimensions

**Note:** All units are in millimeters unless otherwise indicated.

### CPM1A-SRT21

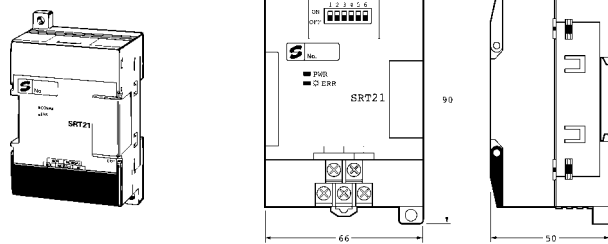

## Installation

### ■ Connection Examples

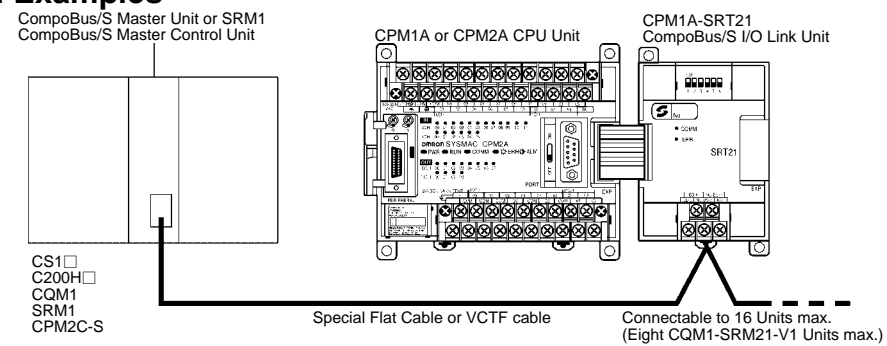

**Note:** A single CompoBus/S I/O Link Unit together with a maximum of two other Expansion I/O Units can be connected to the CPM1A or CPM2A CPU Unit.

#### Long-distance Communications Supported by SRT2 Models (Long-distance/High-speed Communications Selection)

- Ultra-compact at 80 x 48 x 50 (W x H x D) mm for 4-point and 8-point terminals and 105 x 48 x 50 (W x H x D) mm for 16-point terminals.
- Two independent power supplies can be used because the I/O terminals are insulated from the internal circuits.
- DIN track mounting and screw mounting are both supported.



#### Ordering Information

I/O classification	Internal I/O circuit common	I/O points	Rated voltage	I/O rated voltage	Model						
Input	NPN (+ common)	4	24 VDC	24 VDC	SRT2-ID04						
	PNP (- common)				SRT2-ID04-1						
Output	NPN (- common)	4			24 VDC	24 VDC	SRT2-OD04				
	PNP (+ common)						SRT2-OD04-1				
Input	NPN (+ common)	8					24 VDC	24 VDC	SRT2-ID08		
	PNP (- common)								SRT2-ID08-1		
Output	NPN (- common)	8							24 VDC	24 VDC	SRT2-OD08
	PNP (+ common)										SRT2-OD08-1
Input	NPN (+ common)	16	24 VDC	24 VDC							SRT2-ID16
	PNP (- common)										SRT2-ID16-1
Output	NPN (- common)	16			24 VDC	24 VDC					SRT2-OD16
	PNP (+ common)										SRT2-OD16-1

**Note:** For more details about connections supported by the Master Unit, refer to page 25.

#### Specifications

##### ■ Ratings

##### Inputs

Input current	6 mA max./point
ON delay time	1.5 ms max.
OFF delay time	1.5 ms max.
ON voltage	15 VDC min. between each input terminal and V
OFF voltage	5 VDC max. between each input terminal and V
OFF current	1 mA max.
Insulation method	Photocoupler
Input indicators	LED (yellow)

**Outputs**

Rated output current	0.3 A/point
Residual voltage	0.6 V max.
Leakage current	0.1 mA max.
Insulation method	Photocoupler
Output indicators	LED (yellow)

■ **Characteristics**

Communications power supply voltage	14 to 26.4 VDC
I/O power supply voltage	24 VDC +10%/−15%
I/O power supply current	1 A max.
Current consumption (see note)	50 mA max. at 24 VDC
Connection method	Multi-drop method and T-branch method
Connecting Units	4-point and 8-point Terminals: 16 Input Terminals and 16 Output Terminals per Master 16-point Terminals: 8 Input Terminals and 8 Output Terminals per Master
Dielectric strength	500 VAC for 1 min (1-mA sensing current between insulated circuits)
Noise immunity	Conforms to IEC61000-4-4, 2 kV (power lines)
Vibration resistance	10 to 55 Hz, 1.5-mm double amplitude
Shock resistance	Malfunction: 200 m/s <sup>2</sup> Destruction: 300 m/s <sup>2</sup>
Mounting strength	No damage when 50 N pull load was applied for 10 s in all directions
Terminal strength	No damage when 50 N pull load was applied for 10 s
Screw tightening torque	0.6 to 1.18 N • m
Ambient temperature	Operating: 0°C to 55°C (with no icing or condensation) Storage: −20°C to 65°C (with no icing or condensation)
Ambient humidity	Operating: 35% to 85%
Weight	4-point and 8-point Terminals: 80 g max. 16-point Terminals: 110 g max.
Approved standards (4/8 points)	UL 508, CSA C22.2 No. 14

**Note:** The above current consumption is the value with all 4 and 8 and 16 points turned ON excluding the current consumption of the external sensor connected to the input Remote Terminal and the current consumption of the load connected to the output Remote Terminal.

**Nomenclature**

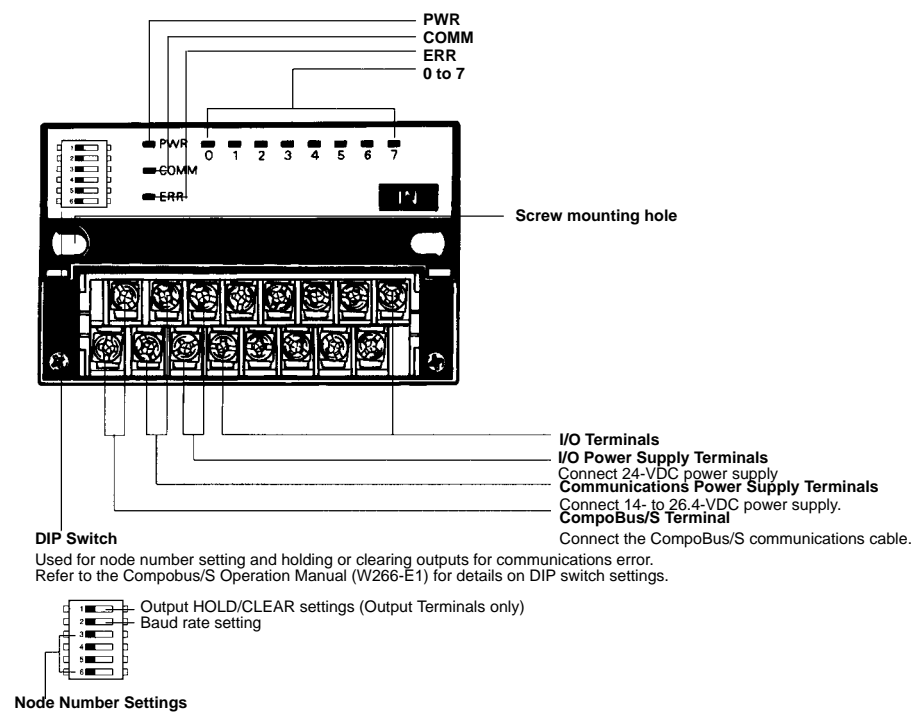

**Indicators**

Indicator	Display	Color	Meaning
PWR	Lit	Green	The communications power supply is ON.
	Not lit		The communications power supply is OFF.
COMM	Lit	Yellow	Normal communications
	Not lit		A communications error has occurred or the Unit is in standby status.
ERR	Lit	Red	A communications error has occurred.
	Not lit		Normal communications or the Unit is in standby status.
0 to 7	Lit	Yellow	The corresponding I/O signal is ON.
	Not lit		The corresponding I/O signal is OFF.

**Output HOLD/CLEAR Mode**

Mode	Pin 1	Setting
HOLD	ON	Output status is maintained.
CLEAR	OFF	Output status is cleared when a communications error occurs.

**Note:** 1. Pin 1 is factory-set to OFF.  
 2. This function is available to Output Terminals only.

**Node Number Settings**

Node number	Pin 3	Pin 4	Pin 5	Pin 6
	8	4	2	1
0	OFF	OFF	OFF	OFF
1	OFF	OFF	OFF	ON
2	OFF	OFF	ON	OFF
3	OFF	OFF	ON	ON
4	OFF	ON	OFF	OFF
5	OFF	ON	OFF	ON
6	OFF	ON	ON	OFF
7	OFF	ON	ON	ON
8	ON	OFF	OFF	OFF
9	ON	OFF	OFF	ON
10	ON	OFF	ON	OFF
11	ON	OFF	ON	ON
12	ON	ON	OFF	OFF
13	ON	ON	OFF	ON
14	ON	ON	ON	OFF
15	ON	ON	ON	ON

**Note:** 1. The node number is factory-set to 0.  
 2. For node number settings, refer to the *CompoBus/S Operation Manual (W266-E1)*.

**Dimensions**

**Note:** All units are in millimeters unless otherwise indicated.

SRT2-ID04 (-1)  
 SRT2-OD04 (-1)  
 SRT2-ID08 (-1)  
 SRT2-OD08 (-1)

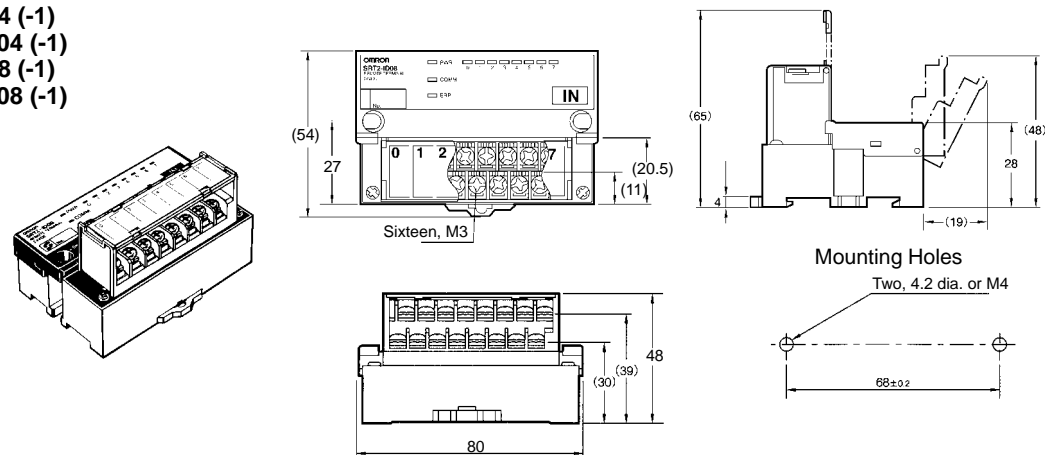



SRT2-ID16 (-1)  
SRT2-OD16 (-1)

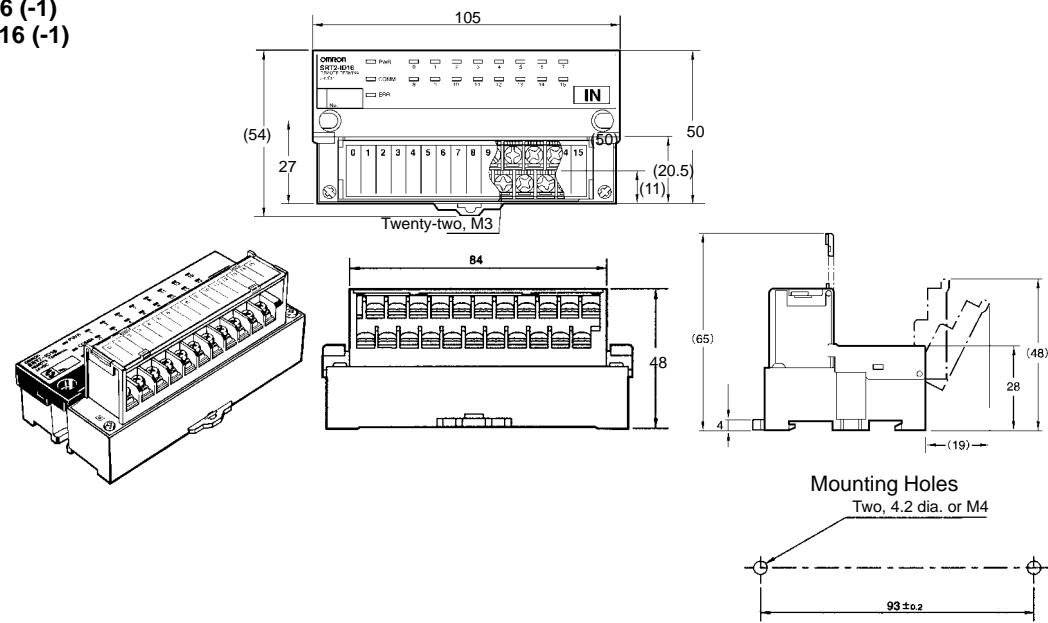

## Installation

### Internal Circuit Configuration

SRT2-ID04

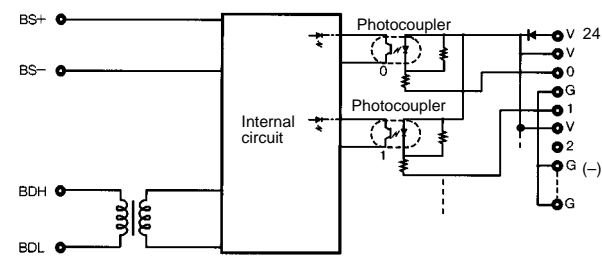

SRT2-ID04-1

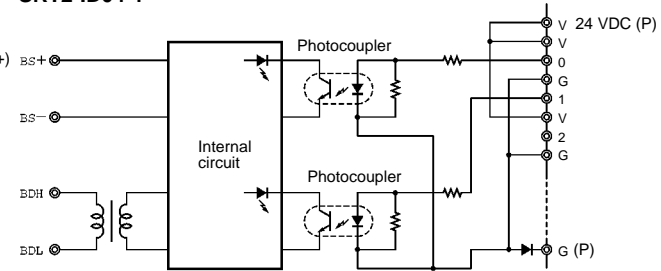

SRT2-OD04

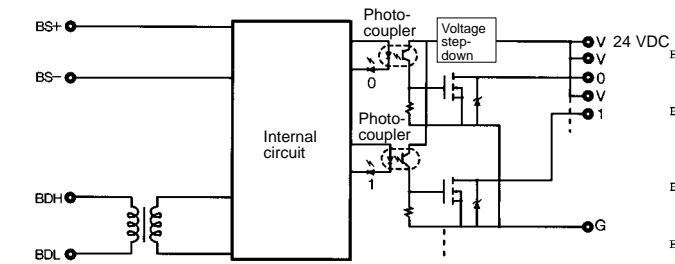

SRT2-OD04-1

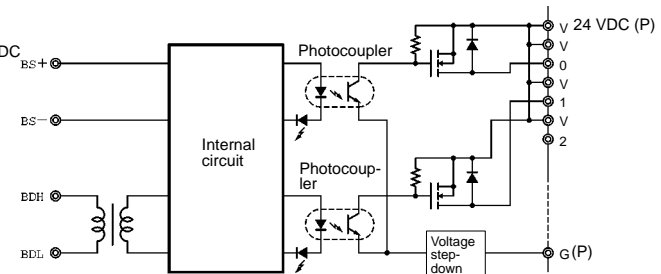

SRT2-ID08

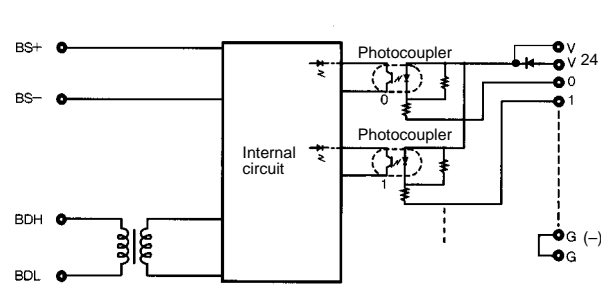

SRT2-ID08-1

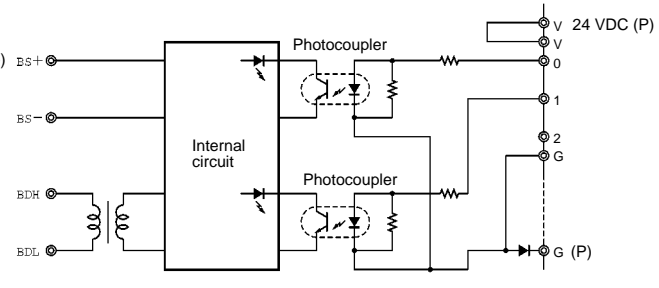

SRT2-OD08

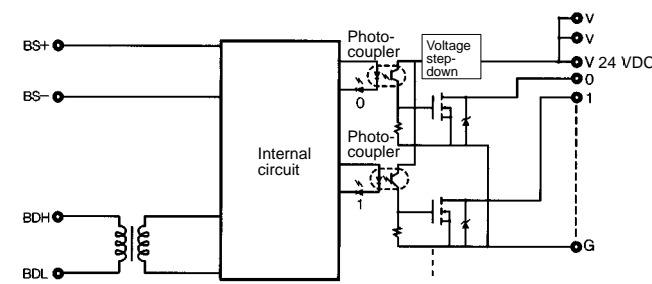

SRT2-OD08-1

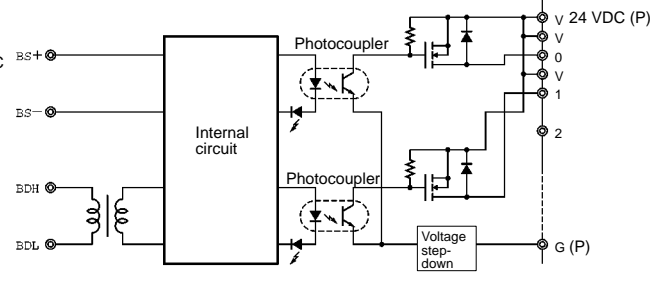

SRT2-ID16

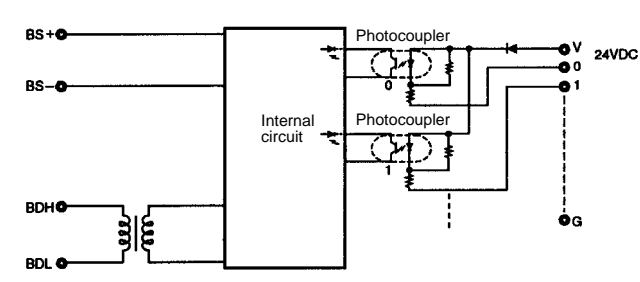

SRT2-ID16-1

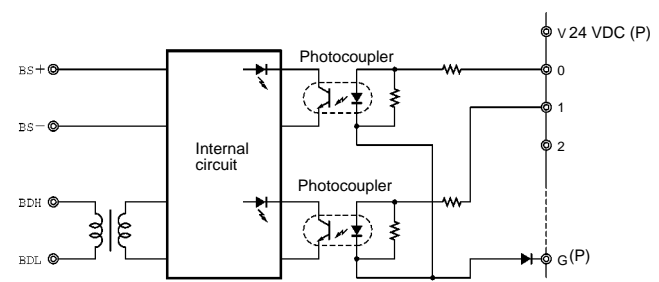

SRT2-OD16

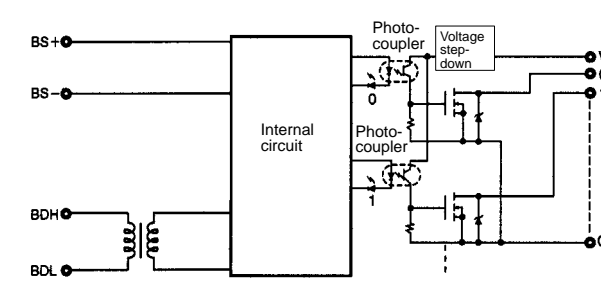

SRT2-OD16-1

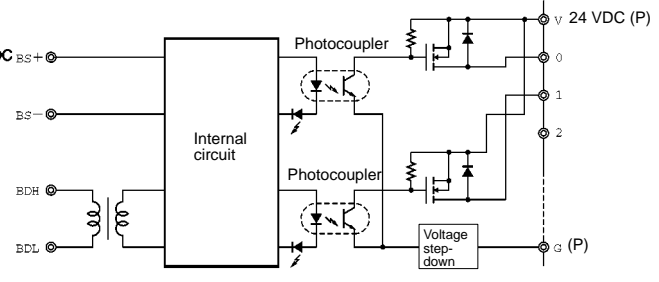

External Connections (NPN Models)

Input

Three-wire Sensors

SRT2-ID04 with NPN Output

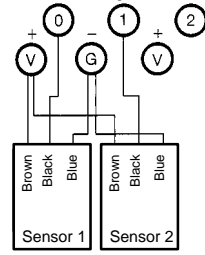

SRT2-ID08 and SRT2-ID16 with NPN Output

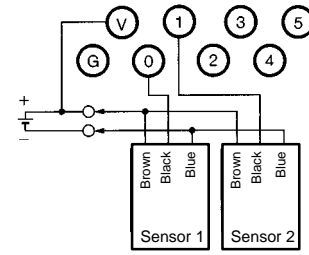

Two-wire Sensors

SRT2-ID04

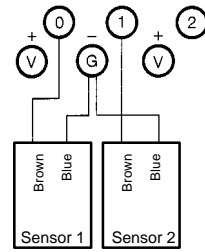

SRT2-ID08 and SRT2-ID16

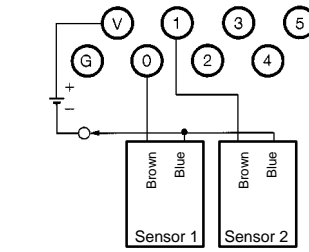

Output

SRT2-OD04

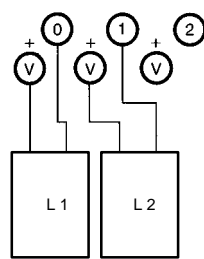

SRT2-OD08 and SRT2-ID16

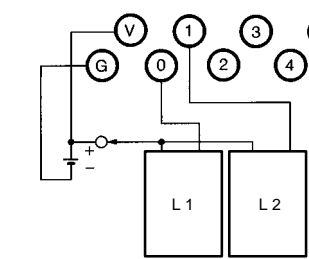

Terminal Arrangement and I/O Device Connection Example (PNP Models)

Note: The connections examples shown are for PNP models.

Input

SRT2-ID04

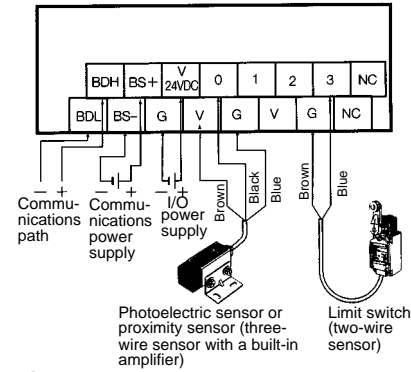

SRT2-ID08

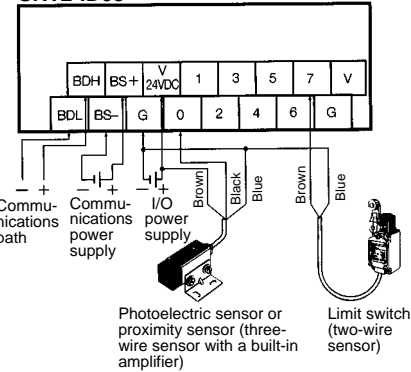

SRT2-ID16

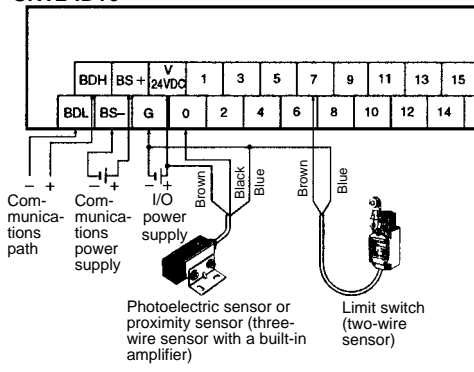

Output

SRT2-OD04

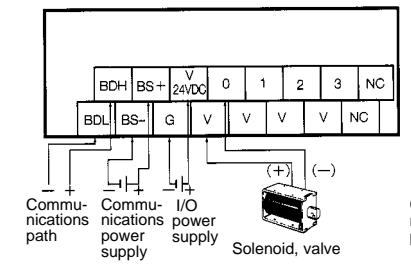

SRT2-OD08

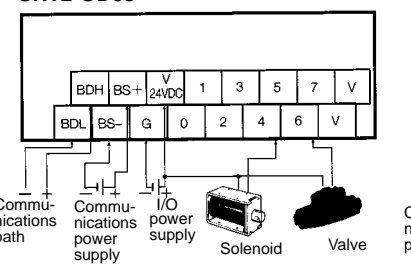

SRT2-OD16

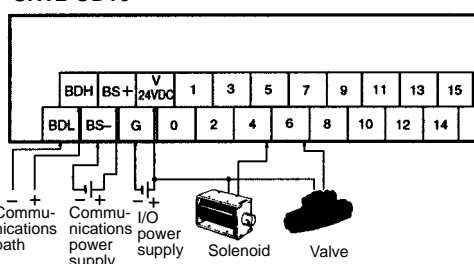

■ External Connections (PNP Models)

Input

Three-wire Sensors

SRT2-ID04-1 with NPN Output

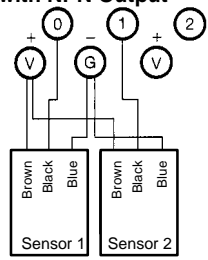

SRT2-ID08-1 and SRT2-ID16-1 with NPN Output

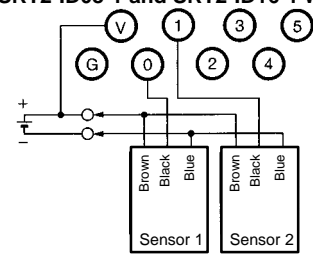

Two-wire Sensors

SRT2-ID04-1

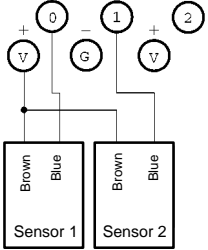

SRT2-ID08-1 and SRT2-ID16-1

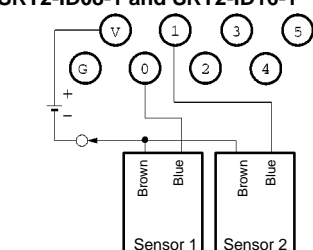

Output

SRT2-OD04-1

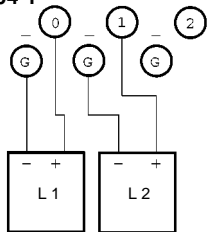

SRT2-OD08-1 and SRT2-ID16-1

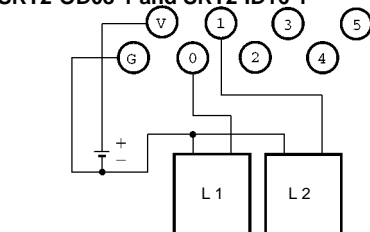

■ Terminal Arrangement and I/O Device Connection Example (PNP Models)

Note: The connections examples shown are for NPN models.

Input

SRT2-ID04-1

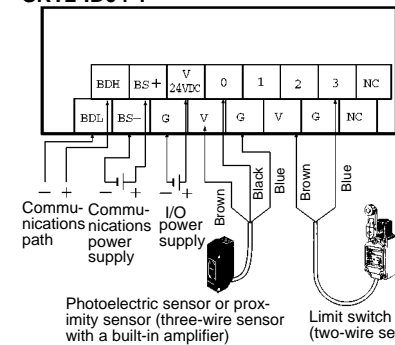

SRT2-ID08-1

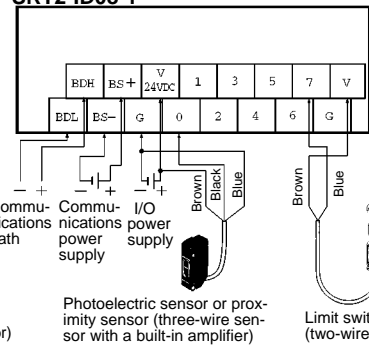

SRT2-ID16-1

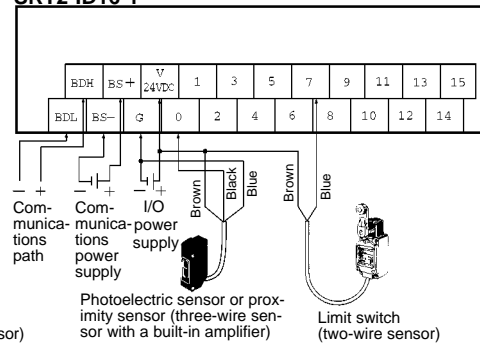

Output

SRT2-OD04-1

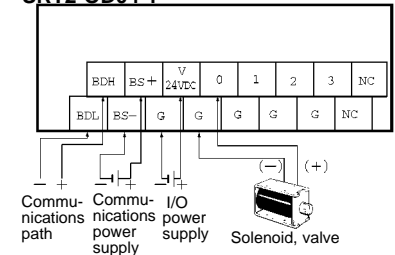

SRT2-OD08-1

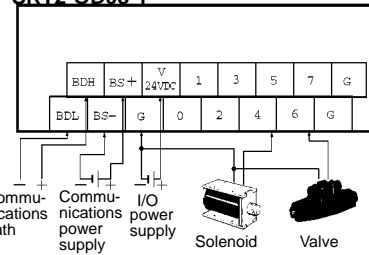

SRT2-OD16-1

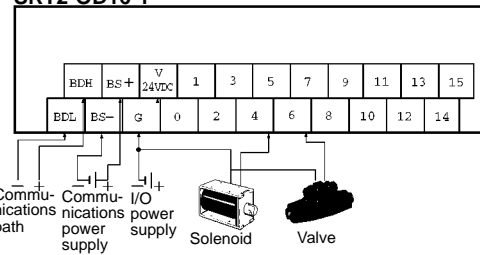

Precautions

Refer to the CompoBus/S Operation Manual (W266-E1) before using the Unit.

**Models with 3-tier Terminals (16 Points)  
Added to the Remote I/O Terminal  
Series.**

**Six Models are Available Depending on  
the NPN or PNP Configuration, Input  
Points, I/O Points, or Output Points.**

- Incorporates easy-to-wire terminals each connecting to a single wire.
- Reduces designing and wiring effort.
- Incorporates a removable circuit block of cassette construction.



## Ordering Information

I/O classification	Internal I/O circuit common	I/O points	I/O connection method	Model
Digital input	NPN (+ common)	16	M3 terminal block	SRT2-ID16T
	PNP (- common)			SRT2-ID16T-1
Digital I/O	NPN (- common)			SRT2-MD16T
	PNP (+ common)			SRT2-MD16T-1
Digital output	NPN (- common)			SRT2-OD16T
	PNP (+ common)			SRT2-OD16T-1

## Specifications

### ■ Ratings

#### Inputs

Input current	6 mA max./point at 24 V and 3 mA min./point at 17 V
ON delay time	1.5 ms max.
OFF delay time	1.5 ms max.
ON voltage	NPN: 15 VDC min. between V terminals and each input terminal PNP: 15 VDC min. between G terminals and each input terminal
OFF voltage	NPN: 5 VDC max. between V terminals and each input terminal PNP: 5 VDC max. between G terminals and each input terminal
OFF current	1 mA max.
Insulation method	Photocoupler

#### Outputs

Rated output current	0.5 A max./point
Residual voltage	1.2 V max.
ON delay time	0.5 ms max.
OFF delay time	1.0 ms max.
Leakage current	0.1 mA max.
Insulation method	Photocoupler

■ Characteristics

Communications power supply voltage	14 to 26.4 VDC
I/O power supply voltage	24 VDC +10%/−15%
I/O power supply current	4 A max./common
Current consumption (see note)	50 mA max. at 24 VDC
Connection method	Multi-drop method and T-branch method
Dielectric strength	500 VAC between insulated circuits
Noise immunity	Conforms to IEC61000-4-4, 2 kV (power lines)
Vibration resistance	10 to 150 Hz, 1.0-mm double amplitude or 70 m/s <sup>2</sup>
Shock resistance	200 m/s <sup>2</sup>
Mounting strength	No damage with 100 N pull load applied in all directions.
Terminal strength	No damage with 100 N pull load applied
Screw tightening torque	0.3 to 0.5 N • m
Ambient temperature	Operating: −10°C to 55°C Storage: −25°C to 65°C
Ambient humidity	Operating: 25% to 85% (with no condensation)
Weight	300 g max.

**Note:** The above current consumption is the value with all points turned ON excluding the current consumption of the external sensor connected to the input Remote Terminal and the current consumption of the load connected to the output Remote Terminal.

Nomenclature

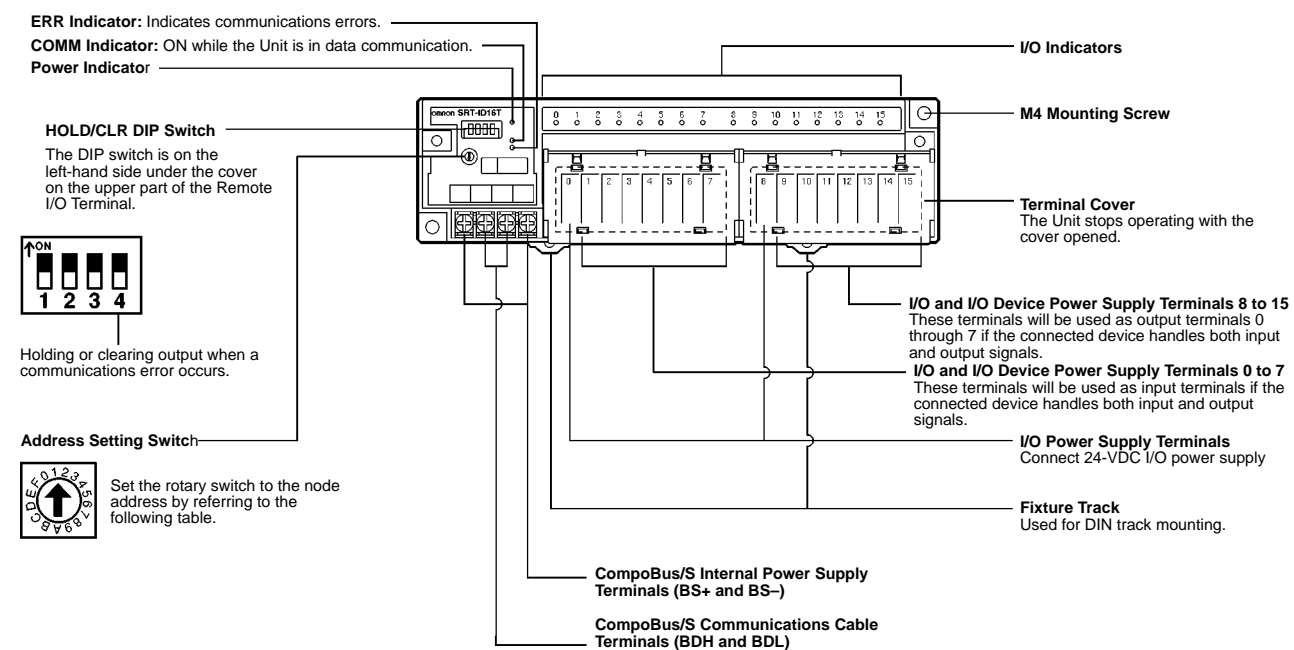

Address Setting Switch

Node address	Setting (Hex)
0	0
1	1
2	2
3	3
4	4
5	5
6	6
7	7

Node address	Setting (Hex)
8	8
9	9
10	A
11	B
12	C
13	D
14	E
15	F

# Dimensions

Note: All units are in millimeters unless otherwise indicated.

SRT2-ID16T (-1)  
SRT2-MD16T (-1)  
SRT2-OD16T (-1)

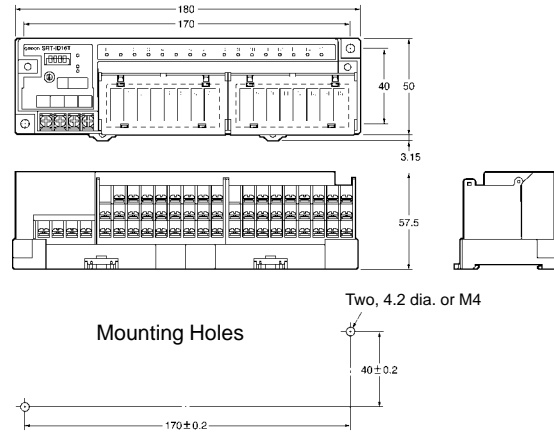
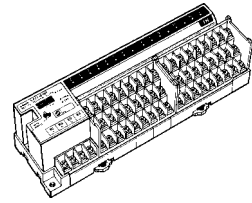

# Installation

## Internal Circuit Configuration

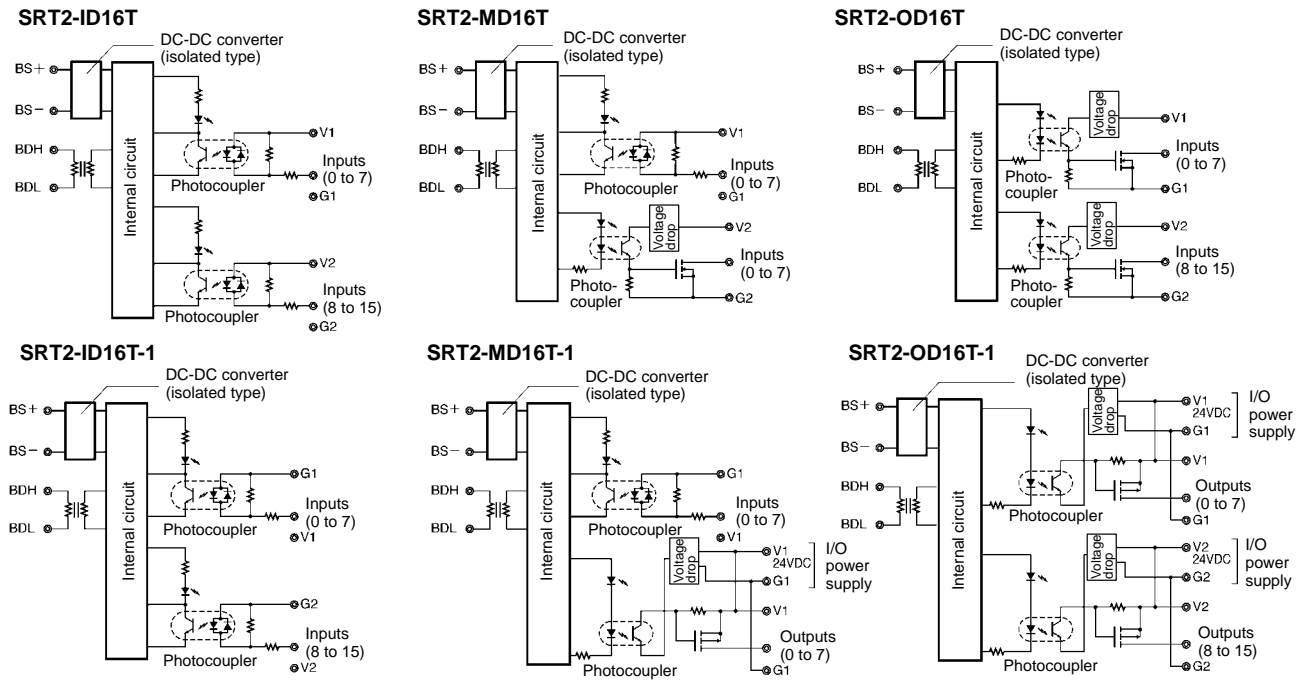

## External Connections

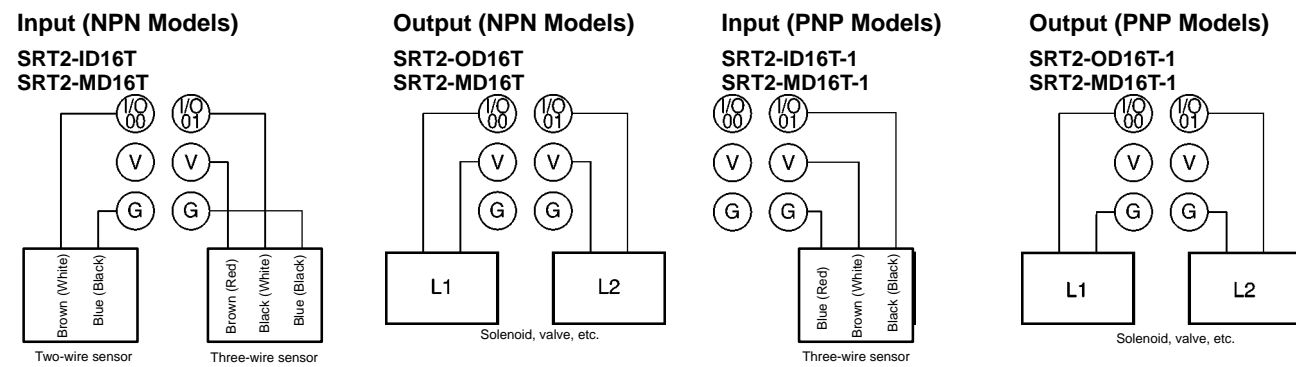

### Ultra-miniature 8-point and 16-point Relay-mounted Terminals

- Ultra-compact  
(8-point models: 101 x 51 x 51 mm (W x H x D);  
16-point models: 156 x 51 x 51 mm (W x H x D))
- Power MOS FET Relay and Relay models.
- DIN track mounting and screw mounting are available.



### Ordering Information

Classification	I/O points	Rated voltage	Relay coil rating	Model	Applicable relay
Relay output	8 points	24 VDC	24 VDC	SRT2-ROC08	G6D-1A
	16 points			SRT2-ROC16	
Power MOS FET relay output	8 points			SRT2-ROF08	G3DZ-2R6PL
	16 points			SRT2-ROF16	

**Note:** For details about connections to the Master Unit, refer to page 12.

### Specifications

#### ■ Ratings

##### Relay Output

Item	SRT2-ROC08, SRT2-ROC16
Applicable relay	G6D-1A (one for each output point)
Rated load	3 A at 250 VAC, 3 A at 30 VDC (resistive load)
Rated carry current	3 A (see note 1)
Max. contact voltage	250 VAC, 30 VDC
Max. contact current	3 A
Max. switching capacity	730 VA (AC), 90 W (DC)
Min. permissible load (see note 2)	10 mA at 5 VDC
Life expectancy	Electrical: 100,000 operations min. (rated load, at 1,800 operations/h) Mechanical: 20,000,000 operations min. (at 18,000 operations/h)

**Note:** 1. The maximum permissible current of COM0 to COM7 is 3 A.

2. This value fulfills the P reference value of opening/closing at a rate of 120 times per min (ambient operating environment and determination criteria according to JIS C5442).

##### Power MOS FET Relay Output

Item	SRT2-ROF08, SRT2-ROF16
Applicable relay	G3DZ-2R6PL (one for each output point)
Load voltage	3 to 264 VAC, 3 to 125 VDC
Load current	100 $\mu$ A to 0.3 A
Inrush current	6 A (10 ms)



■ Characteristics

Power supply voltage	24 VDC +10%/−15%
Current consumption (see note)	350 mA max. at 24 VDC
Connection method	Multi-drop method and T-branch method
Connecting Units	8-point Units: 16 per Master 16-point Units: 8 per Master
Dielectric strength	2,000 VAC for 1 min (1-mA sensing current) between all output terminals and power supply, between communication terminals, and between contacts of different polarities 500 VAC for 1 min (1-mA sensing current) between all output terminals and power supply, between communication terminals, and between all power supply terminals and communications terminals
Noise immunity	Conforms to IEC61000-4-4, 2 kV (power lines)
Vibration resistance	10 to 55 Hz, 0.75-mm double amplitude
Shock resistance	Malfunction: 100 m/s <sup>2</sup> Destruction: 300 m/s <sup>2</sup>
Mounting strength	No damage when 50 N pull load was applied for 10 s in all directions
Terminal strength	No damage when 50 N pull load was applied for 10 s
Screw tightening torque	0.6 to 1.18 N • m
Ambient temperature	Operating: 0°C to 55°C (with no icing or condensation) Storage: −20°C to 65°C (with no icing or condensation)
Ambient humidity	Operating: 35% to 85%
Weight	8-point models: 145 g max., 16-point models: 240 g max.
Approved standards	UL 508, CSA C22.2 No. 14

**Note:** The above current consumption is a value with all the points turned ON including the current consumption of the G6D coil for the Remote Output Terminal, and the G3DZ's input current.

Reference Data

G6D-1A (24 VDC)

Life Expectancy

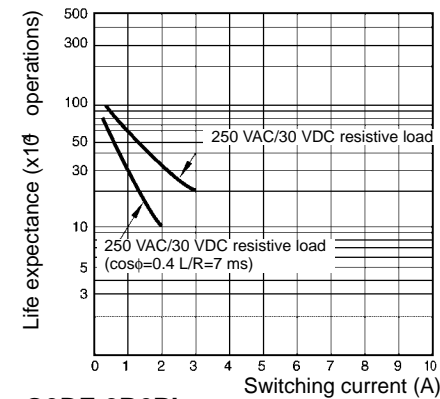

Max. Switching Capacity

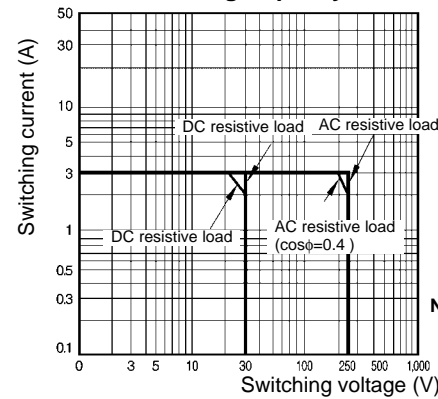

**Note:** These graphs show the characteristics for when the SRT2-ROF□□ or B1T-JR model is mounted.

G3DZ-2R6PL  
Load Current vs. Ambient Temperature Characteristics

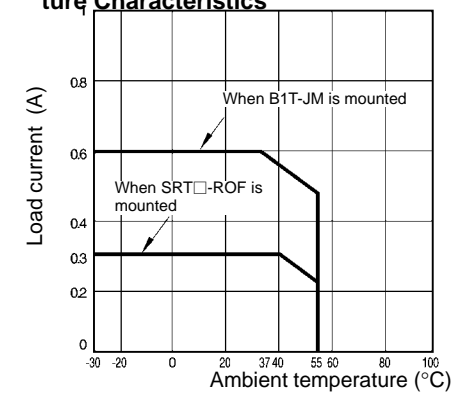

Inrush Current Resistivity

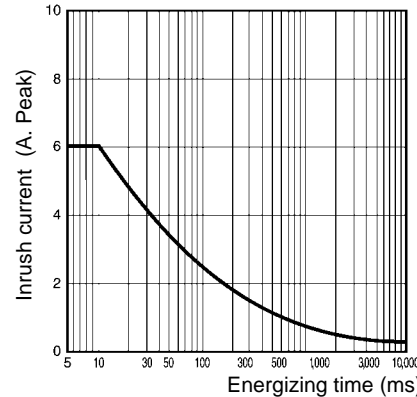

Non-repetitive: (Keep the inrush current to half the rated value if it occurs repetitively.)

**Note:** The above graph shows the characteristics for when the SRT2-ROF□□ or B1T-JM model is mounted.

# Nomenclature

SRT2-ROC16  
SRT2-ROF16

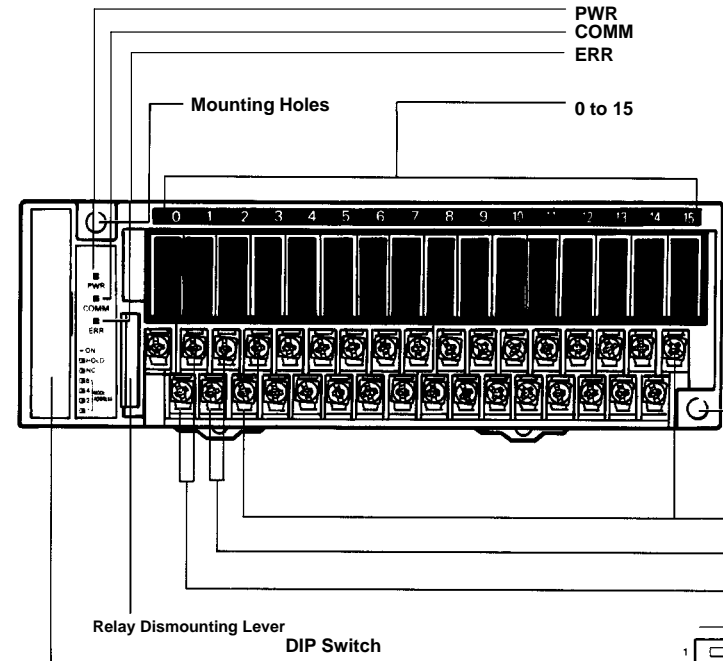

### Indicators

Indicator	Display	Color	Meaning
PWR	Lit	Green	The communications power supply is ON.
	Not lit		The communications power supply is OFF.
COMM	Lit	Yellow	Normal communications
	Not lit		A communications error has occurred or the Unit is in standby status.
ERR	Lit	Red	A communications error has occurred.
	Not lit		Normal communications or the Unit is in standby status.
0 to 15 (see note)	Lit	Yellow	The corresponding I/O signal is ON.
	Not lit		The corresponding I/O signal is OFF.

**Note:** The SRT2-RO□08 does not have indicators 8 to 15.

**Note:** Always turn off the Unit before changing DIP switch settings.

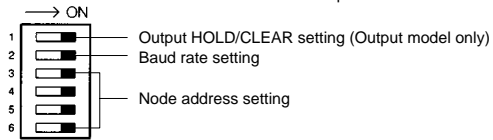

SRT2-ROC08  
SRT2-ROF08

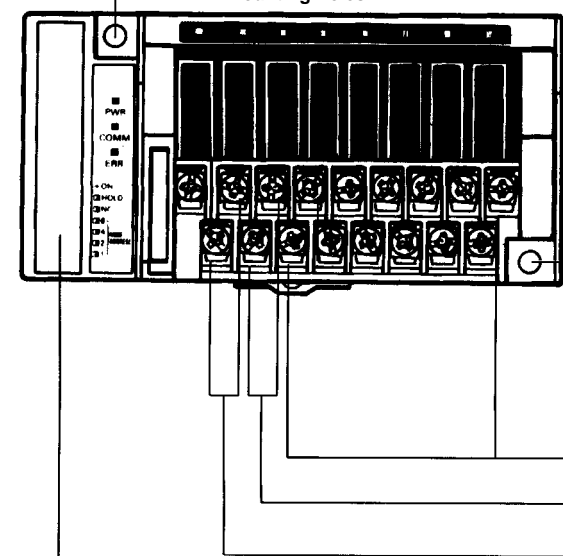

**DIP Switch**  
Used for node number setting and holding or clearing outputs for communications error.

**Output HOLD/CLEAR Mode**

Mode	Pin 1	Setting
HOLD	ON	Output status is maintained when a communications error occurs.
CLEAR	OFF	Output status is cleared when a communications error occurs.

**Note:** 1. Pin 1 is factory-set to OFF.  
 2. This function is available to the Output Terminal only.

**Node Number Settings**

Node number	Pin 3	Pin 4	Pin 5	Pin 6
	8	4	2	1
0	OFF	OFF	OFF	OFF
1	OFF	OFF	OFF	ON
2	OFF	OFF	ON	OFF
3	OFF	OFF	ON	ON
4	OFF	ON	OFF	OFF
5	OFF	ON	OFF	ON
6	OFF	ON	ON	OFF
7	OFF	ON	ON	ON
8	ON	OFF	OFF	OFF
9	ON	OFF	OFF	ON
10	ON	OFF	ON	OFF
11	ON	OFF	ON	ON
12	ON	ON	OFF	OFF
13	ON	ON	OFF	ON
14	ON	ON	ON	OFF
15	ON	ON	ON	ON

**Note:** 1. The node number is factory-set to 0.  
 2. For node number setting, refer to the *CompoBus/S Operation Manual (W266-E1)*.

# Dimensions

Note: All units are in millimeters unless otherwise indicated.

**SRT2-ROC08**  
**SRT2-ROF08**

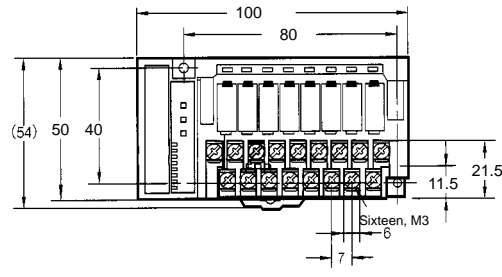
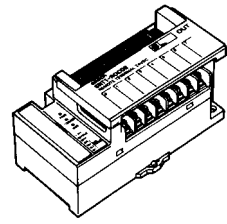

**Mounting Holes**

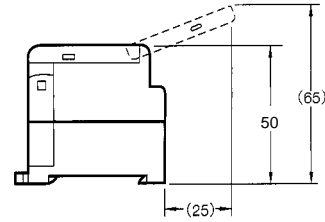
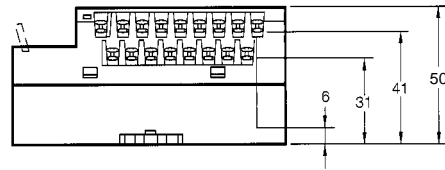
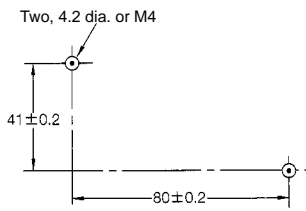

**SRT2-ROC16**  
**SRT2-ROF16**

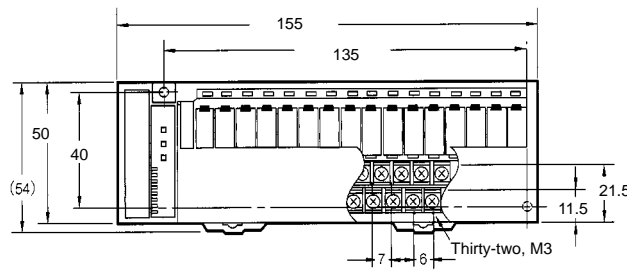
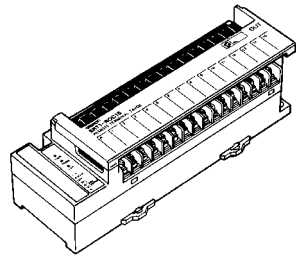

**Mounting Holes**

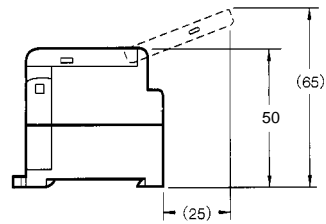
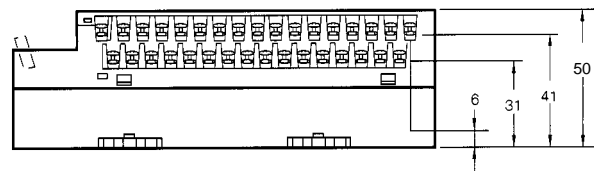
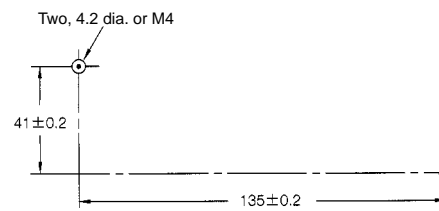

# Installation

## Internal Circuit Configuration

SRT2-ROC08  
SRT2-ROC16

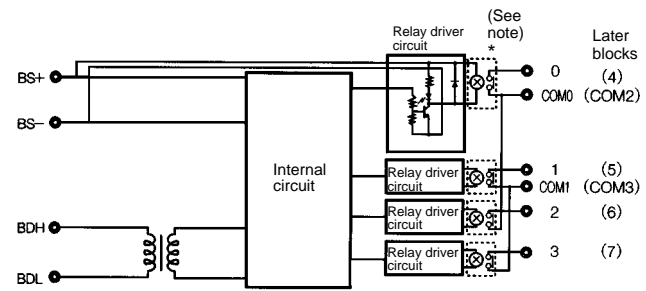

**Note:** The G3DZ-2R6PL Power MOS FET Relay is inserted into this portion of the SRT2-ROF08 and SRT2-ROF16.

## External Connections

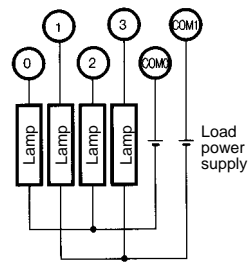

## Terminal Arrangement and I/O Device Connection Example

Output  
SRT2-ROC16  
SRT2-ROF16

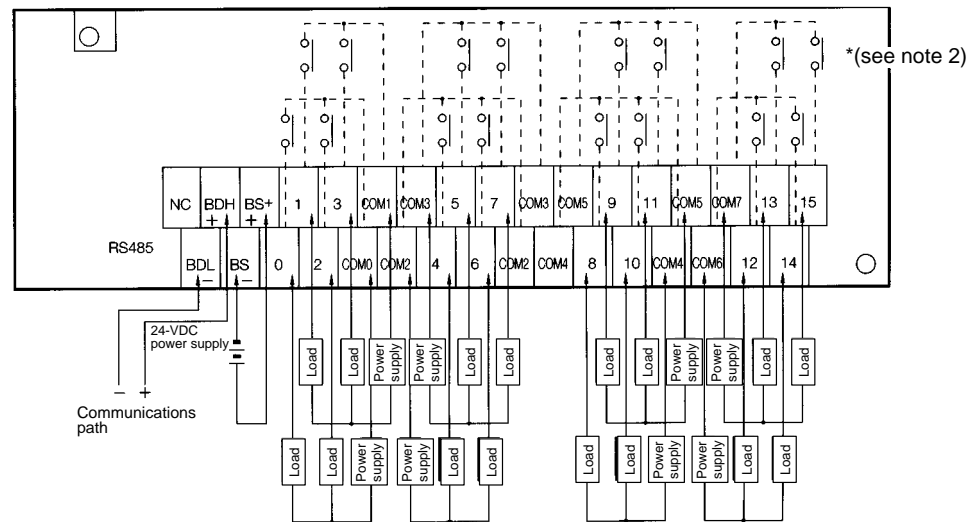

- Note:**
1. Dotted lines indicate internal connections. SRT2-ROC08 and SRT2-ROF08 have the 0 to 7 and COM0 to COM3 terminals only.
  2. The above is a connection example of the SRT2-ROC16 with G6D Relays mounted. G3DZ Power MOS FET Relays are mounted to the SRT2-ROF08 and SRT2-ROF16.

# Precautions

Refer to the *CompoBus/S Operation Manual (W266-E1)* before using the Unit.

## Subminiature 32-point Remote Terminal with Connectors

- Compact dimensions: 35 × 60 × 80 (W × D × H)
- Long-distance and high-speed communications modes available.
- Downsizing enabled with 32-point MIL connector for I/O connection.



## Ordering Information

I/O classification	Internal I/O circuit common	I/O points	I/O connection method	Rated voltage for communications power supply	Rated voltage for I/O power supply	Model
Input	NPN (+ common)	32	MIL connector	24 VDC	24 VDC	SRT2-ID32ML
	PNP (- common)					SRT2-ID32ML-1
Output	NPN (- common)					SRT2-OD32ML
	PNP (+ common)					SRT2-OD32ML-1
Input and output	NPN (input: + common; output - common)					SRT2-MD32ML
	PNP (input: - common; output: + common)					SRT2-MD32ML-1
Mounting hook B (see note)						SRT2-ATT02

**Note:** Mounting hook B is required when not mounting to a DIN track.

## Specifications

### ■ Ratings

#### Inputs

Item	SRT2-ID32ML	SRT2-MD32ML	SRT2-ID32ML-1	SRT2-MD32ML-1
<b>ON voltage</b>	15 VDC min. (Between each input terminal and V.)		15 VDC min. (Between each input terminal and G.)	
<b>OFF voltage</b>	5 VDC max. (Between each input terminal and V.)		5 VDC max. (Between each input terminal and G.)	
<b>OFF current</b>	1.0 mA max.			
<b>Input current</b>	6.0 mA max. at 24 VDC 3.0 mA max. at 17 VDC (Between each input terminal and V.)		6.0 mA max. at 24 VDC 3.0 mA max. at 17 VDC (Between each input terminal and G.)	
<b>Input impedance</b>	4.4 kΩ			
<b>ON delay time</b>	1.5 ms max.			
<b>OFF delay time</b>	1.5 ms max.			
<b>Number of circuits</b>	32 points/common, 1 circuit	16 points/common, 1 circuit	32 points/common, 1 circuit	16 points/common, 1 circuit

**Outputs**

Item	SRT2-OD32ML	SRT2-MD32ML	SRT2-OD32ML-1	SRT2-MD32ML-1
<b>Output current</b>	0.3 A/point 4-A common (See notes 1 and 3.)	0.3 A/point 2-A common (See notes 2 and 3.)	0.3 A/point 4-A common (See notes 1 and 3.)	0.3 A/point 2-A common (See notes 2 and 3.)
<b>Residual voltage</b>	1.2 V max. (Between the 0.3-A DC output terminal and G.)		1.2 V max. (Between the 0.3-A DC output terminal and V.)	
<b>Leakage current</b>	0.1 mA max. (Between the 24-VDC output terminal and G.)		0.1 mA max. (Between the 24-VDC output terminal and V.)	
<b>ON delay time</b>	0.5 ms max.			
<b>OFF delay time</b>	1.5 ms max.			
<b>Insulation method</b>	Photocoupler		Photocoupler	
<b>Number of circuits</b>	32 points/common, 1 circuit	16 points/common, 1 circuit	32 points/common, 1 circuit	16 points/common, 1 circuit

- Note:**
1. Ensure that the total external load current does not exceed 4 A.
  2. Ensure that the total external load current does not exceed 2 A.
  3. Ensure that the current per terminal for the V/G terminals does not exceed 1 A.

■ **Characteristics**

<b>Communications power supply voltage</b>	14 to 26.4 VDC
<b>I/O power supply voltage</b>	20.4 to 26.4 VDC
<b>Current consumption for communications power supply (also used for internal circuits; see note)</b>	ID32ML/ID32ML-1: 50 mA MD32ML/MD32ML-1: 60 mA OD32ML/OD32ML-1: 70 mA
<b>Dielectric strength</b>	500 VAC for 1 min (Detection current: 1 mA between insulated circuits.)
<b>Vibration resistance</b>	10 to 150 Hz, 0.7-mm double amplitude or 50 m/s <sup>2</sup>
<b>Shock resistance</b>	150 m/s <sup>2</sup>
<b>Ambient temperature</b>	Operating: -10°C to 55°C (with no icing or condensation) Storage: -25°C to 65°C
<b>Ambient humidity</b>	Operating: 25% to 85% (with no condensation)
<b>Weight</b>	ID32ML/ID32ML-1/MD32ML/MD32ML-1: Approx. 100 g max. OD32ML/OD32ML-1: Approx. 90 g

**Note:** The above current consumption is the value with all points turned ON excluding the current consumption of the external sensor connected to the input Remote Terminal and the current consumption of the load connected to the output Remote Terminal.

■ **Applicable Connectors**

Type	Model	Remarks	
Flat cable, pressure-welded	XG4M-4030-T	---	
Stranded wire, pressure-welded	Socket	XG5M-4032-N	For AWG 24
		XG5M-4035-N	For AWG 28 to 26
	Semi-cover	XG5S-2001	---
Hood cover	XG5S-4022	---	

# Nomenclature

## Names of Components

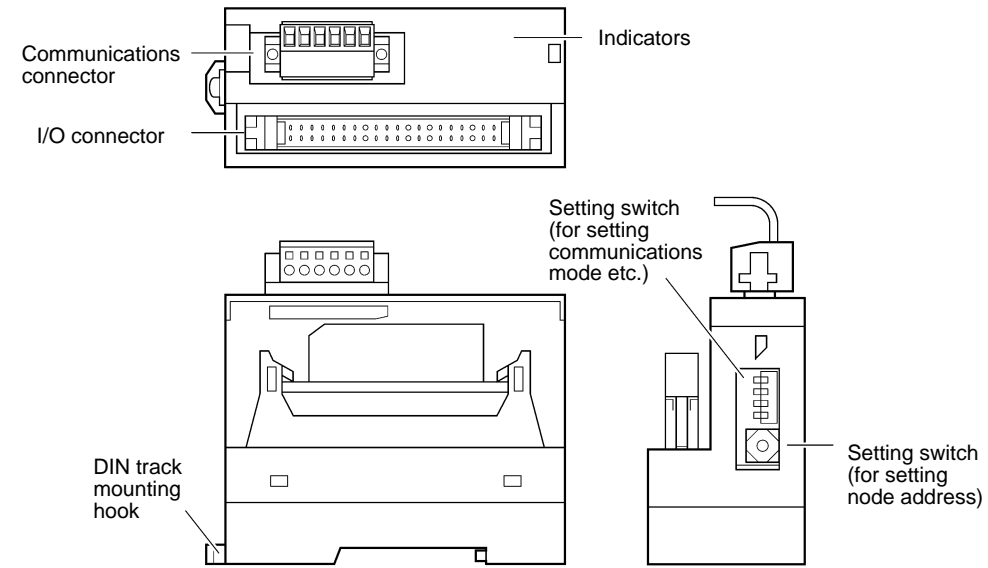

## Relationship between I/O Indicators and Connector

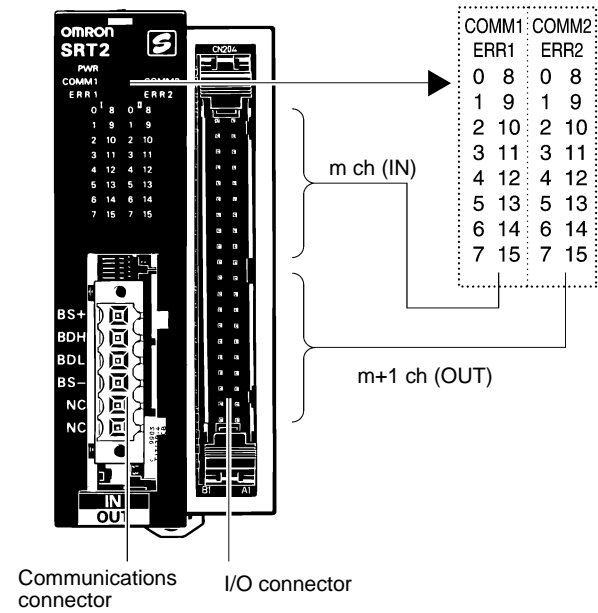



**Indicators**

Display	Name	Color	Status	Meaning
PWR	Power supply indicator	Green	Lit	Power is being supplied by the communications power supply.
			Not lit	Power is not being supplied by the communications power supply.
COMM1 COMM2	Communications indicators	Yellow	Lit	I/O is being exchanged normally.
			Not lit	A communications error has occurred, or the Unit is on standby.
ERR1 ERR2	Communications error indicators	Red	Lit	A communications error has occurred.
			Not lit	I/O is being exchanged normally, or the Unit is on standby.
0 to 15	I/O	Yellow	Lit	The corresponding input or output is ON.
			Not lit	The corresponding input or output is OFF, or on standby.

**Operation**

■ **Switch Settings**

Rotary switch

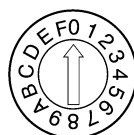

Node address setting

DIP switch

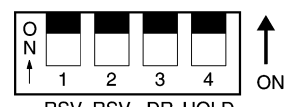

Reserved for system use

Output HOLD/CLEAR Setting (SRT2-OD/MD32ML(-1))  
Reserved for system use (SRT2-ID32ML(-1))

Communications mode setting

**Node Address**

The node address is set to one of the following hexadecimal values using the rotary switch.

Node address	Setting (hexadecimal)	Node address	Setting (hexadecimal)
0	0	8	8
1	1	9	9
2	2	10	A
3	3	11	B
4	4	12	C
5	5	13	D
6	6	14	E
7	7	15	F

**Note:** 1. Note the following points when using with the C200HW-SRM21-V1/SRM1-CO□-V2:

If the maximum number of control points is 128 for inputs and 128 for outputs, node addresses 14 and 15 cannot be used (SRT2-OD/ID32ML(-1)).

If the maximum number of control points is 64 for inputs and 64 for outputs, node addresses in the range 8 to 15 cannot be used.

2. Note the following points when using with the CQM1-SRM21-V1:

In 8-point Mode:

If 2 channels are allocated, node addresses in the range 2 to 15 cannot be used.

If 4 channels are allocated, node addresses in the range 4 to 15 cannot be used.

If 8 channels are allocated, node addresses in the range 8 to 15 cannot be used.

In 4-point Mode:

This Unit cannot be used.

**Communications Mode Setting**

The communications mode is set using SW3 of the DIP switch in the way shown below.

SW3	Communications mode	Communications distance	Communications speed	Communications cycle time
OFF	High-speed communications mode	100 m max.	750 kbps	0.5 ms/0.8 ms
ON	Long-distance communications mode	500 m max.	93.75 kbps	4.0 ms/6.0 ms

**Output HOLD/CLEAR Setting for Communications Errors (SRT2-OD/MD32ML (-1))**

The setting of SW4 of the DIP switch determines whether output data is held or cleared when a communications error occurs.

SW4 (HOLD)	Setting
OFF	Output status is cleared.
ON	Output status is held.

# Dimensions

Note: All units are in millimeters unless otherwise indicated.

SRT2-ID32ML(-1)  
SRT2-OD32ML(-1)  
SRT2-MD32ML(-1)

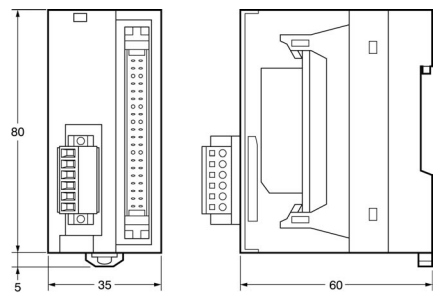

SRT2-ATT02

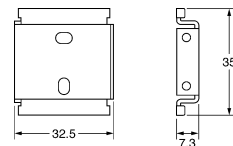

# Installation

## Internal Circuit Configuration

SRT2-ID32ML

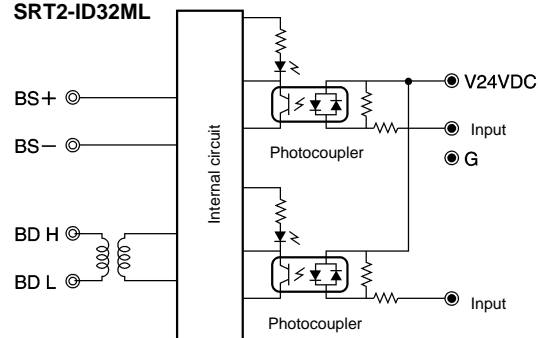

SRT2-ID32ML-1

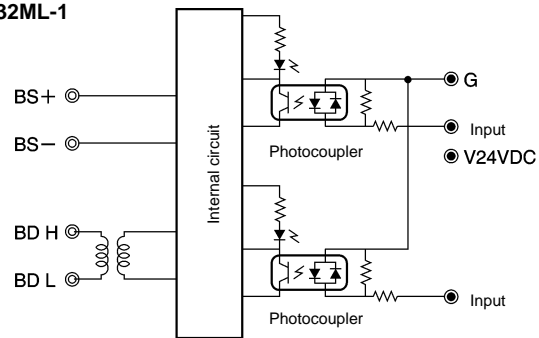

SRT2-OD32ML

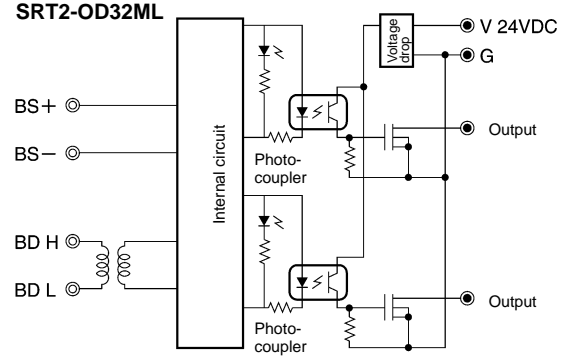

SRT2-OD32ML-1

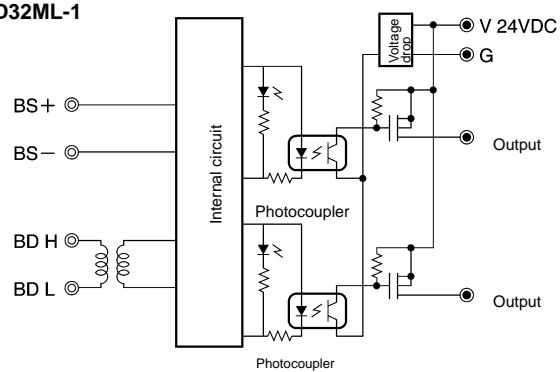

SRT2-MD32ML

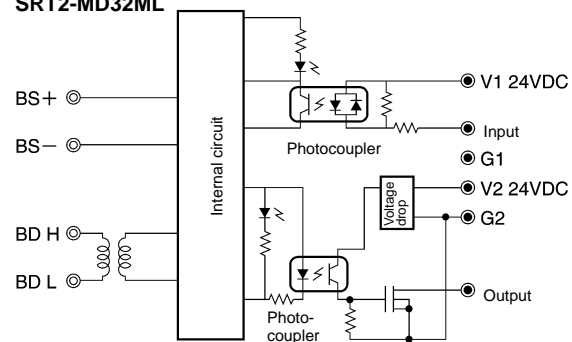

SRT2-MD32ML-1

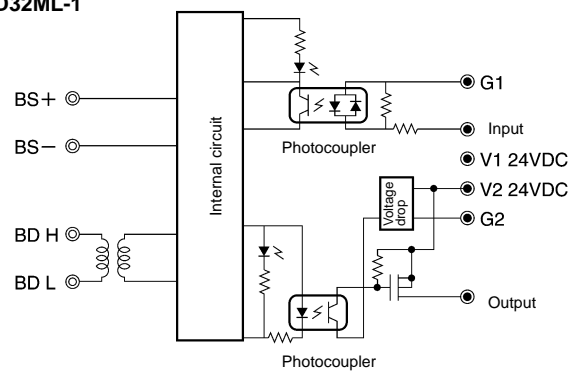

■ Terminal Arrangement

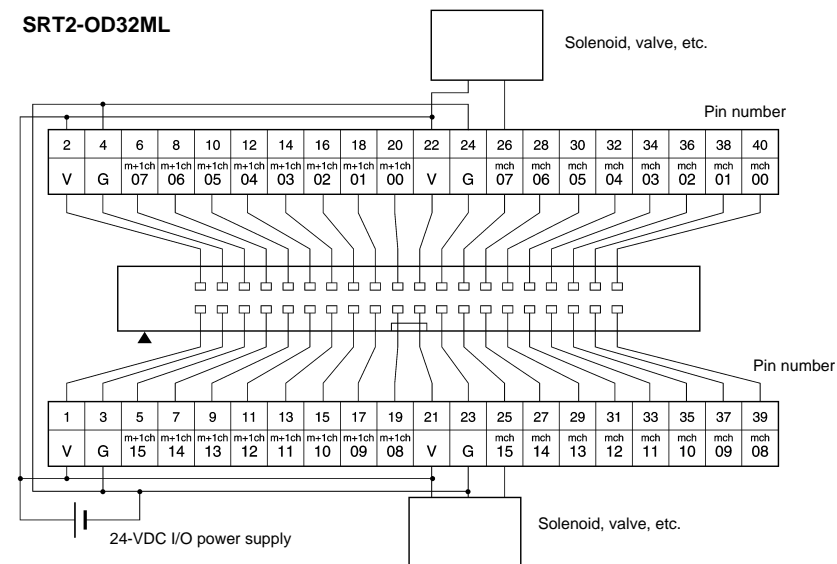
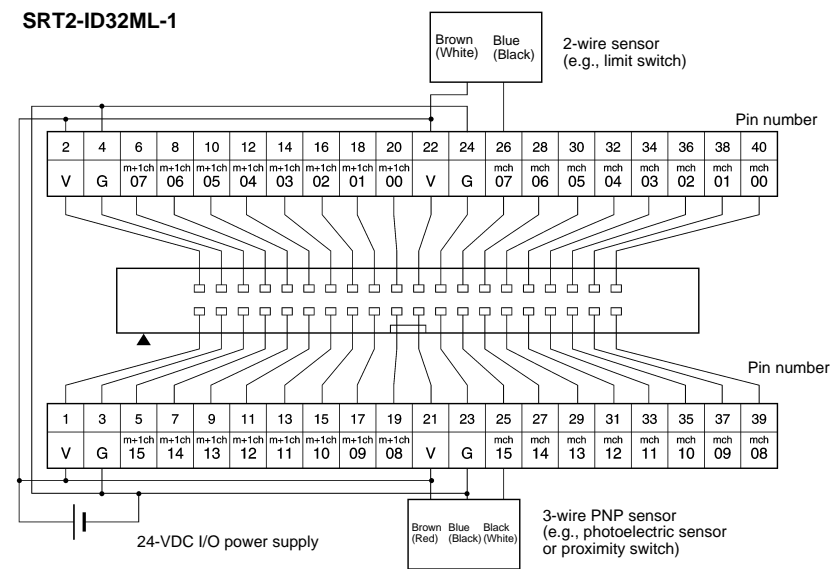
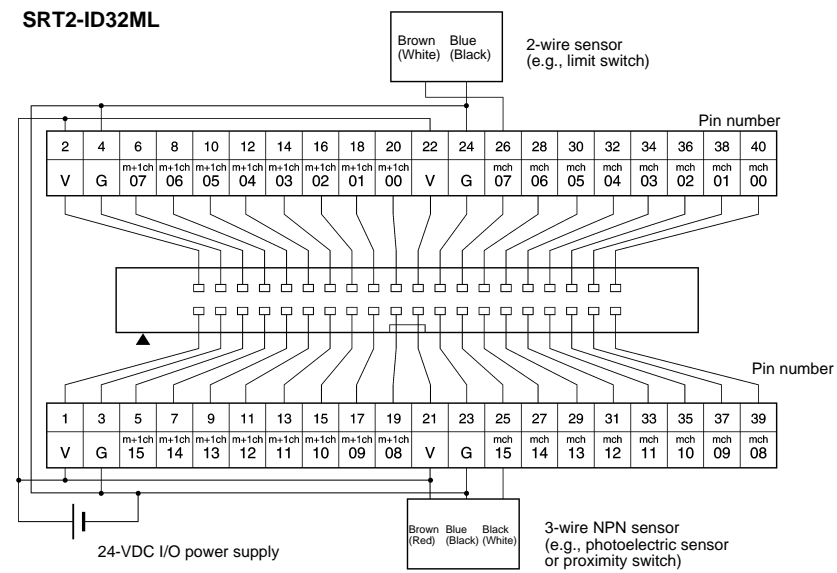

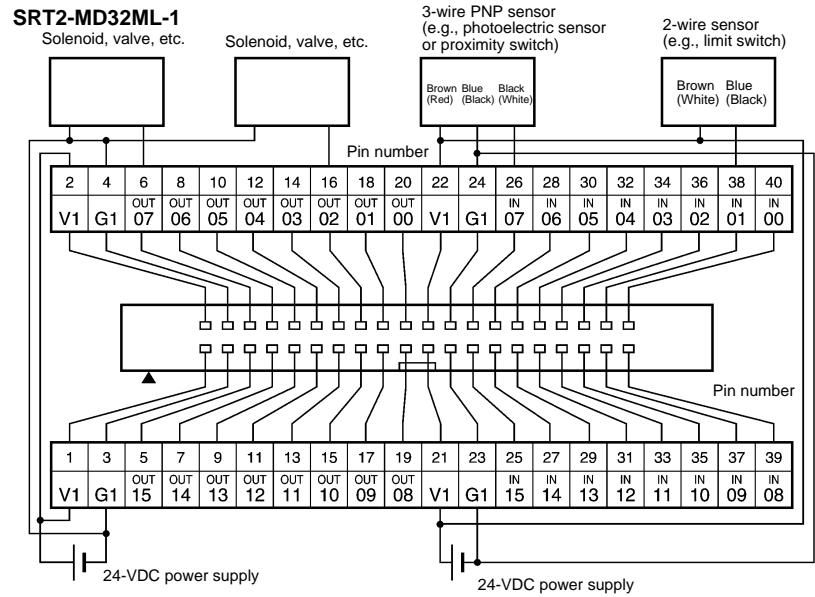
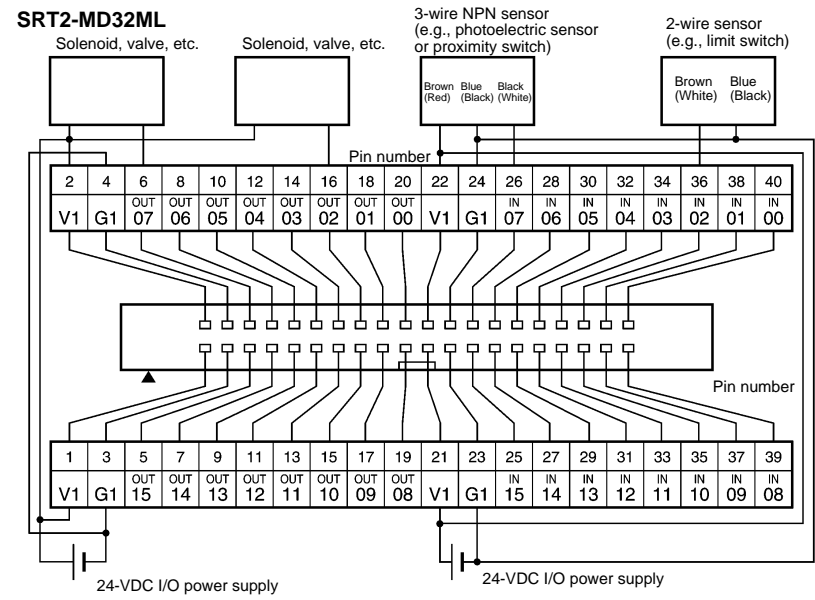
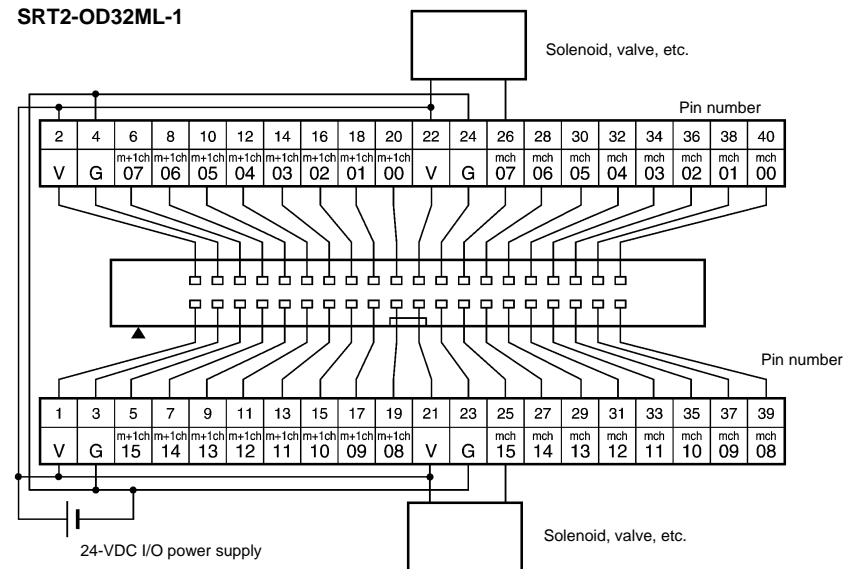

# Precautions

For details on available communications connectors, refer to page 105.

## Communications Connector Pin Arrangement

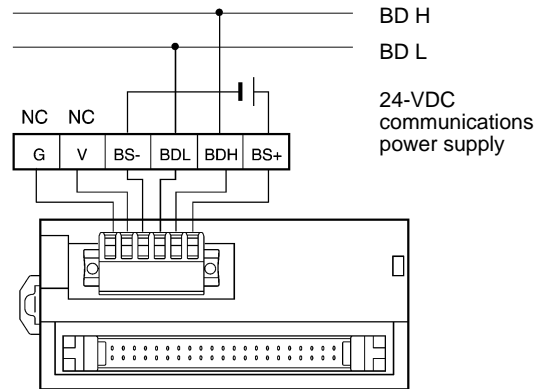

### Applicable Cables

#### Cables with Connectors (2-to-1 Connection)

Model	Connected product	Applicable Cable	Remarks
SRT2-ID32ML	G7TC-ID16 G7TC-IA16	G79-I50-25-D1 (50 cm) G79-I75-50-D1 (75 cm)	---
SRT2-MD32ML	Input side: G7TC-ID16 G7TC-IA16  Output side: G7TC-OC16/OC18 G70D-SOC16/VSOC16 G70A-ZOC16-3	G79-M50-25-D1 (50 cm) G79-M75-50-D1 (75 cm)	Inputs and outputs are distinguished by color. The tube for the input side is red and the tube for the output side is yellow.
SRT2-OD32ML	G7TC-OC16/OC08 G70D-SOC16/VSOC16 G70A-ZOC16-3	G79-O50-25-D1 (50 cm) G79-O75-50-D1 (75 cm)	---
SRT2-ID32ML-1	G70A-ZIM16-5	G79-I50-25-D2 (50 cm) G79-I75-50-D2 (75 cm)	---
SRT2-MD32ML-1	Input side: G70A-ZIM16-5  Output side: G70A-ZOC16-4 G70D-SOC16-1	G79-M50-25-D2 (50 cm) G79-M75-50-D2 (75 cm)	Inputs and outputs are distinguished by color. The tube for the input side is red and the tube for the output side is yellow.
SRT2-OD32ML-1	G70A-ZOC16-4 G70D-SOC16-1	G79-O50-25-D1 (50 cm) G79-O75-50-D1 (75 cm)	---
	G7TC-OC16-1	G79-I50-25-D1 (50 cm) G79-I75-50-D1 (75 cm)	---

#### Cables with Connectors (1-to-1 Connection)

Model	Connected product	Applicable Cable	Remarks
All models	XW2B-40G XW2B-40G5 XW2D-40G6	XW2Z-C25K (25 cm)	XW2B-40G4 XW2B-40G5
		XW2Z-C50K (50 cm)	

#### Cables with Crimp Terminals

Model	Connected product	Applicable Cable	Remarks
All models	---	G79-Y100C-D1 (1 m)	---
		G79-Y200C-D1 (2 m)	
		G79-Y500C-D1 (5 m)	

#### Cables with Stranded Wires

Model	Connected product	Applicable Cable	Remarks
All models	---	G79-A200C-D1 (2 m)	---
		G79-A500C-D1 (5 m)	

## Compact Remote I/O Terminals that Save Wiring Effort and Enable Long-distance Communications

- Long-distance or high-speed communications mode is selectable.
- Incorporates I/O connectors making it possible to minimize the size.
- I/O connectors save wiring effort.
- Flexible DIN track mounting is possible through a DIN track attachment.
- Eight-point sensor connector models and 16-point MIL connector models are the same size.



### ■ Features

Vertical or horizontal DIN track mounting according to the available space is possible. Saves space and easily connects to other devices without wiring effort.

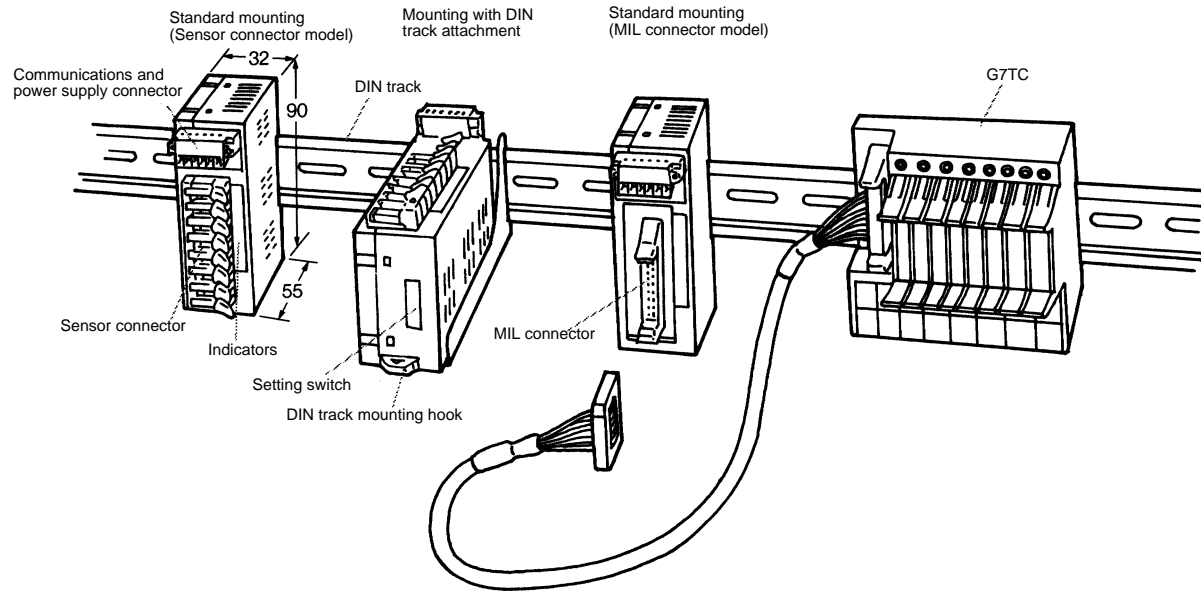

## Ordering Information

I/O classification	Internal I/O circuit common	I/O points	I/O connection method	Model
Digital input	NPN (+ common)	8	Sensor connector	SRT2-VID08S
	PNP (- common)			SRT2-VID08S-1
Digital output	NPN (- common)			SRT2-VOD08S
	PNP (+ common)			SRT2-VOD08S-1
Digital input	NPN (+ common)	16	MIL connector	SRT2-VID16ML
	PNP (- common)			SRT2-VID16ML-1
Digital output	NPN (- common)			SRT2-VOD16ML
	PNP (+ common)			SRT2-VOD16ML-1
Mounting hook A				SRT2-ATT01
Mounting hook B				SRT2-ATT02

**Note:** For details about connecting the SRT2-VID or SRT2-VOD to the Master Unit, refer to page 25.

## Specifications

### ■ Ratings

#### Inputs

Item	SRT2-VID08S SRT2-VID08S-1	SRT2-VID16ML SRT2-VID16ML-1
Input current	6 mA max./point at 24 V, 3 mA max./point at 17 V	
ON delay time	1.5 ms max.	
OFF delay time	1.5 ms max.	
ON voltage	15 VDC min. (Between each input terminal and V: NPN. Between each input and G: PNP.)	
OFF voltage	5 VDC max. (Between each input terminal and V: NPN. Between each input and G: PNP.)	
OFF current	1 mA max.	
Insulation method	Photocoupler	
Maximum number of inputs	8	12
Number of circuits	8 points/common, 1 circuit	16 points/common, 1 circuit

#### Outputs

Item	SRT2-VID08S SRT2-VID08S-1	SRT2-VID16ML SRT2-VID16ML-1
Rated output current	0.3 A/point	0.3 A/point (2-A common) (See note.)
Residual voltage	1.2 V max.	
ON delay time	0.5 ms max.	
OFF delay time	1.5 ms max.	
Leakage current	0.1 mA max.	
Insulation method	Photocoupler	
Number of circuits	8 points/common, 1 circuit	16 points/common, 1 circuit

**Note:** When using V/G terminals in an MIL connector, ensure that the current per terminal for the V/G terminals does not exceed 1 A.

### ■ Characteristics

Communications power supply voltage	14 to 26.4 VDC
I/O power supply voltage	20.4 to 26.4 VDC (24 VDC <sup>+10%</sup> / <sub>-15%</sub> )
I/O power supply current	Sensor connector: 2.4 A max., MIL connector: 2.0 A max.
Current consumption (see note)	50 mA max. at 24 VDC
Noise immunity	Conforms to IEC61000-4-4, 2 kV (power lines)
Vibration resistance	10 to 150 Hz, 1.0-mm double amplitude or 70 m/s <sup>2</sup> (50 m/s <sup>2</sup> for SRT2-ATT02)
Shock resistance	200 m/s <sup>2</sup>
Dielectric strength	500 VAC (between insulated circuits)
Ambient temperature	Operating: -10°C to 55°C (with no icing or condensation) Storage: -25°C to 65°C
Ambient humidity	Operating: 25% to 85% (with no condensation) Storage: 25% to 85%
Mounting strength	No damage when 100 N pull load was applied in all directions (40 N load for SRT2-ATT02)
Terminal strength	No damage when the following loads were applied: Communications connector: 100 N Sensor connector: 40 N MIL connector: 100 N
Screw tightening torque	Communications connector: 0.25 N • m
Node address setting	Settings made at DIP switch (set before supplying power for Slave communications)
Weight	Approx. 75 g max.

**Note:** The above current consumption is the value with all points turned ON excluding the current consumption of the external sensor connected to the input Remote Terminal and the current consumption of the load connected to the output Remote Terminal.

# Nomenclature

SRT2-VID08S/SRT2-VID08S-1  
SRT2-VOD08S/SRT2-VOD08S-1  
(Sensor Connector Models)

Communications Connectors

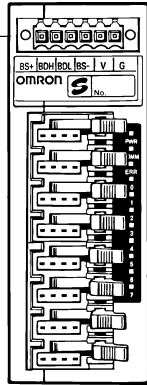

I/O Connectors

Indicators

Indicator	Name	Color	Display	Meaning
PWR	Power	Green	Lit	The communications power supply is ON.
			Not lit	The communications power supply is OFF.
COMM	Communi-cations	Yellow	Lit	Normal communications
			Not lit	A communications error has occurred or the Unit is in standby status.
ERR	Communi-cations error	Red	Lit	A communications error has occurred.
			Not lit	Normal communications or the Unit is in standby status.
0 to 7 (for 8-point I/O)	Input (output)	Yellow	Lit	The corresponding I/O signal is ON.
			Not lit	The corresponding I/O signal is OFF.

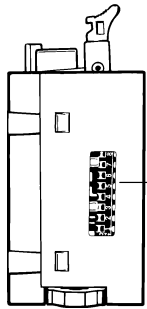

DIP Switch

Output HOLD/CLEAR Mode Setting  
Output HOLD/CLEAR Mode

SW8 (HOLD)	Setting
OFF	Output status is cleared.
ON	Output status is maintained.

Communications Mode Setting  
Communications Mode

SW7 (DR)	Setting
OFF	High-speed communications mode
ON	Long-distance communications mode

Reserved for System Use (Always OFF)  
Node Address Setting

Node number	Pin 4	Pin 3	Pin 2	Pin 1
	8	4	2	1
0	OFF	OFF	OFF	OFF
1	OFF	OFF	OFF	ON
2	OFF	OFF	ON	OFF
3	OFF	OFF	ON	ON
4	OFF	ON	OFF	OFF
5	OFF	ON	OFF	ON
6	OFF	ON	ON	OFF
7	OFF	ON	ON	ON
8	ON	OFF	OFF	OFF
9	ON	OFF	OFF	ON
10	ON	OFF	ON	OFF
11	ON	OFF	ON	ON
12	ON	ON	OFF	OFF
13	ON	ON	OFF	OFF
14	ON	ON	ON	OFF
15	ON	ON	ON	ON

**Note:** Be sure to perform settings with the Slave power supply OFF.

SRT2-VID16ML/SRT2-VID16ML-1  
SRT2-VOD16ML/SRT2-VOD16ML-1  
(MIL Connector Models)

Communications Connectors

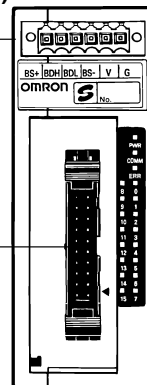

I/O Connectors

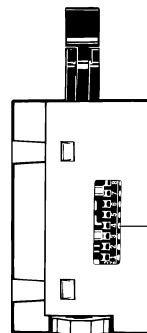



# Dimensions

Note: All units are in millimeters unless otherwise indicated.

SRT2-VID08S  
SRT2-VID08S-1  
SRT2-VOD08S  
SRT2-VOD08S-1

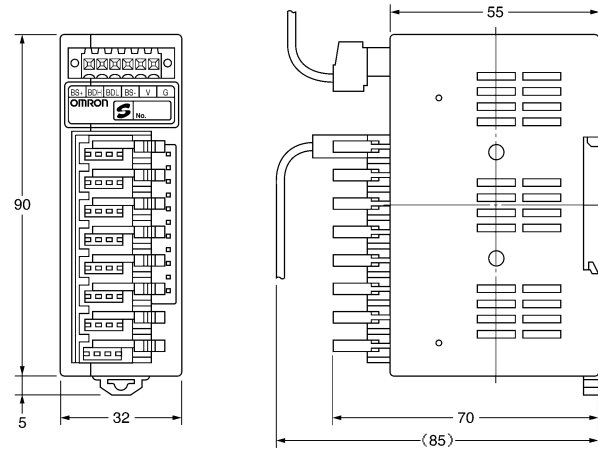
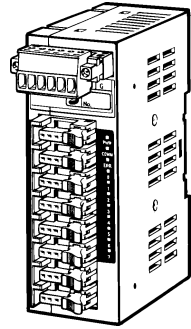

SRT2-VID16ML  
SRT2-VID16ML-1  
SRT2-VOD16ML  
SRT2-VOD16ML-1

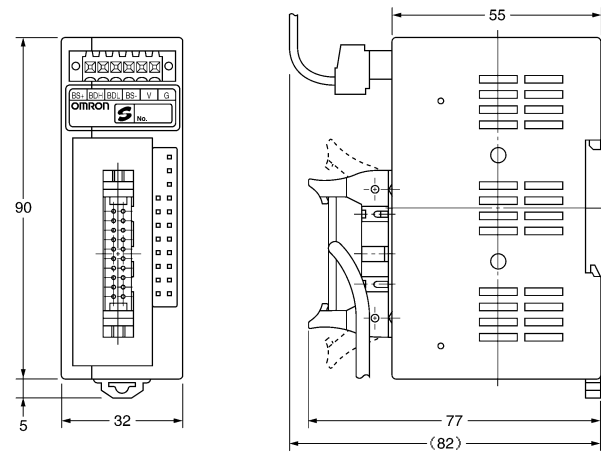
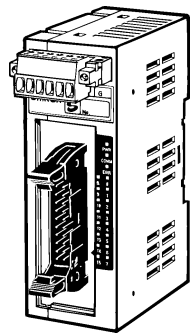

SRT2-ATT01

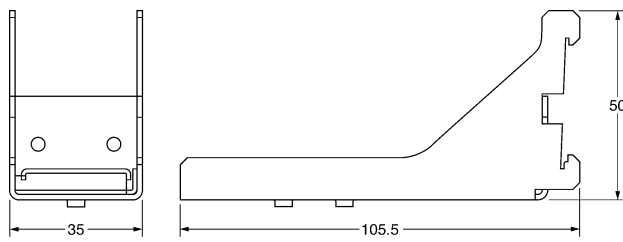

Dimensions when Unit is mounted.

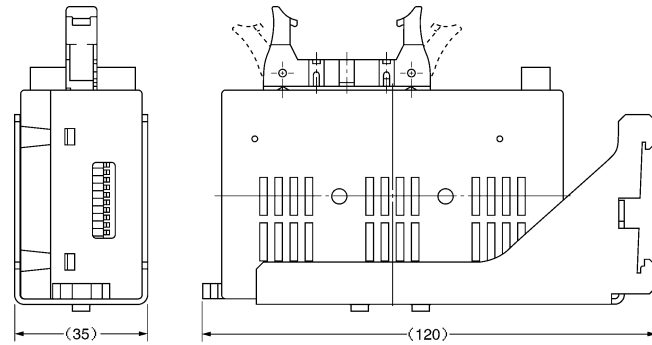

SRT2-ATT02

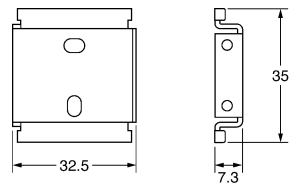

# Installation

## Internal Circuit Configuration

**SRT2-VID08S**

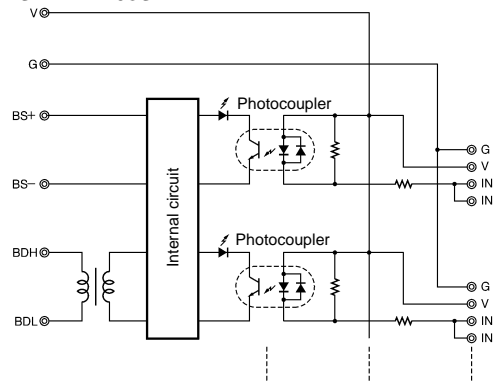

**SRT2-VID08S-1**

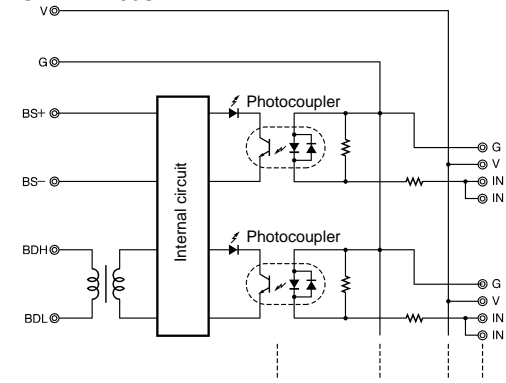

**SRT2-VOD08S**

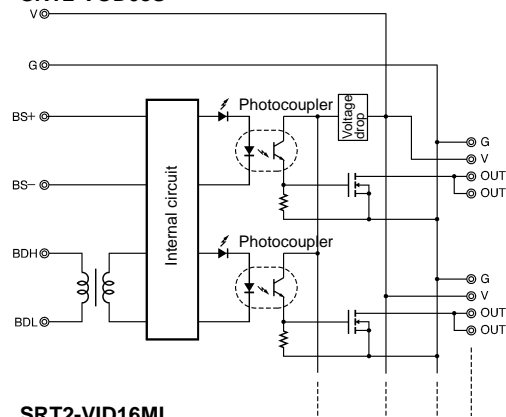

**SRT2-VOD08S-1**

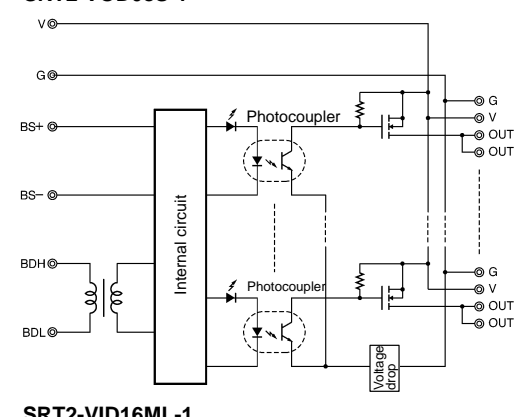

**SRT2-VID16ML**

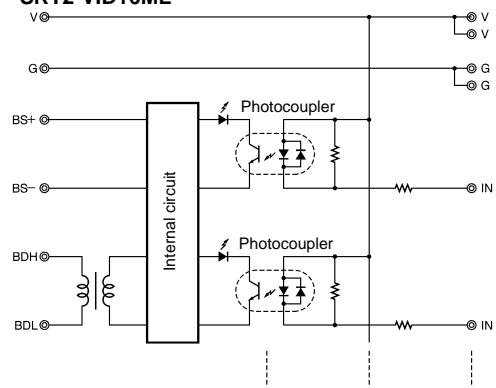

**SRT2-VID16ML-1**

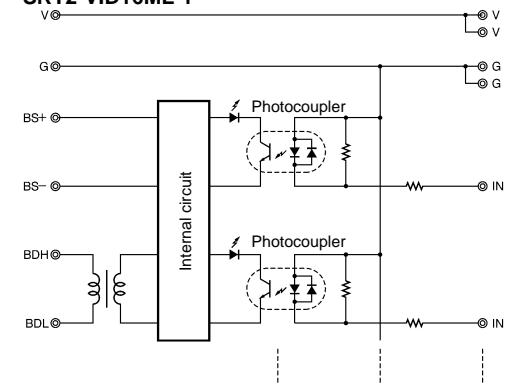

**SRT2-VOD16ML**

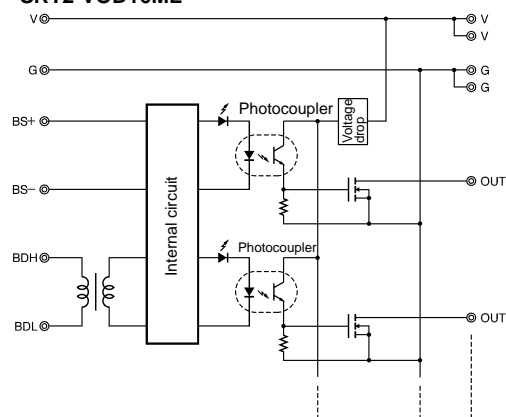

**SRT2-VOD16ML-1**

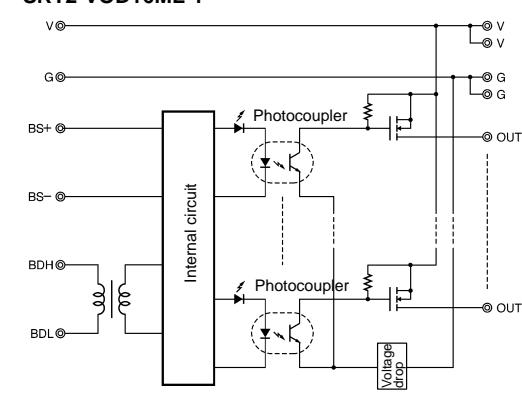

■ Terminal Arrangement and I/O Device Connection Examples

SRT2-VID08S

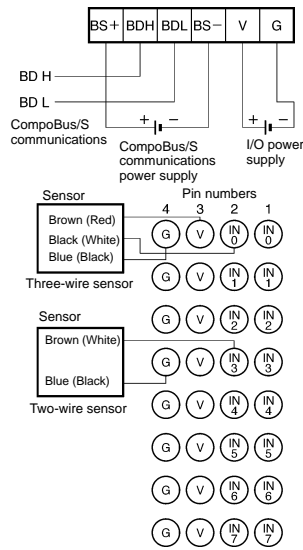

SRT2-VID08S-1

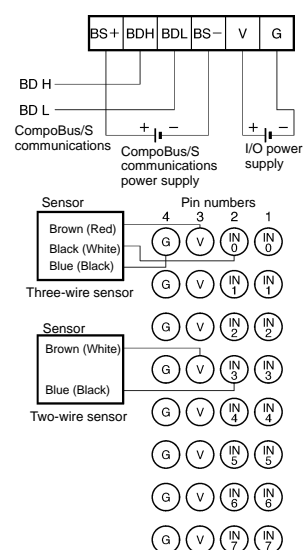

SRT2-VOD08S

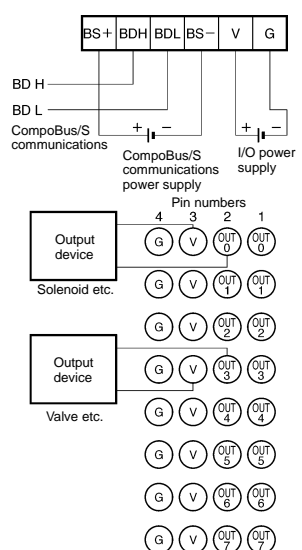

SRT2-VOD08S-1

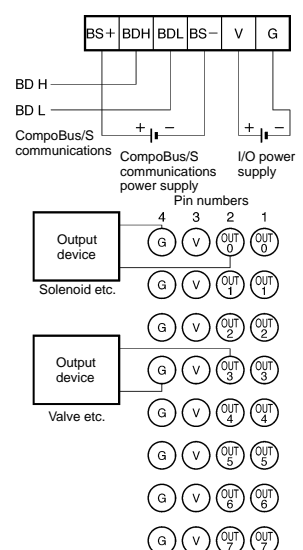

SRT2-VID16ML

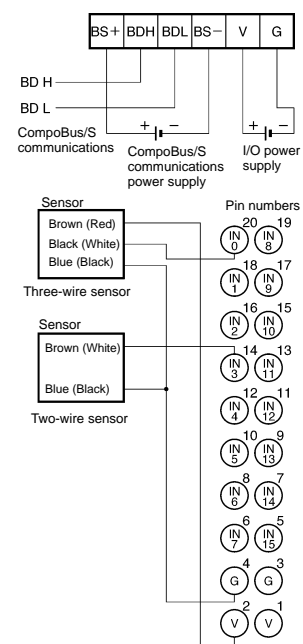

SRT2-VID16ML-1

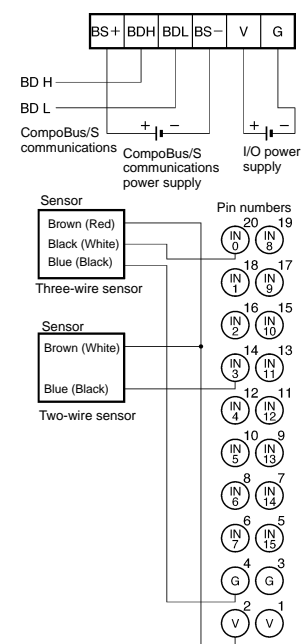

SRT2-VOD16ML

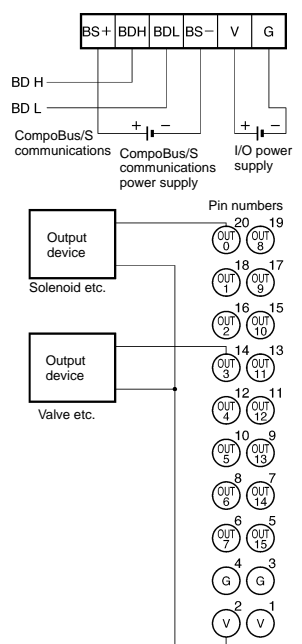

SRT2-VOD16ML-1

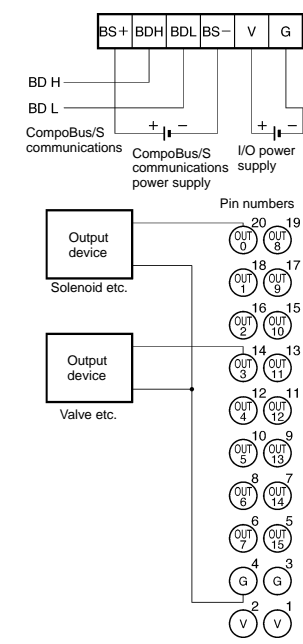

- Note:**
1. V terminals and G terminals are respectively connected internally.  
When supplying power for I/O from communications connectors, power can be supplied to the sensor output devices from V and G terminals.
  2. When using an inductive load (solenoid, valve etc.), either use one with an internal reverse electromotive force absorption diode or attach a diode externally.

# Precautions

Refer to the *CompoBus/S Operation Manual (W266-E1)* before using the Unit.

## Communications Connector Pin Arrangement

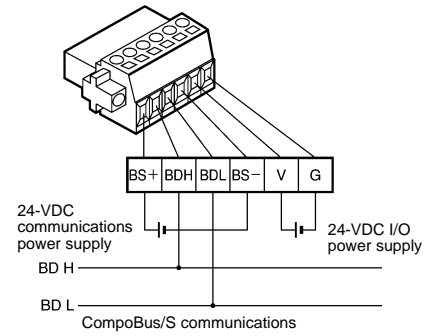

The following solderless terminals are recommended.

- Manufacturer: Weidmuller

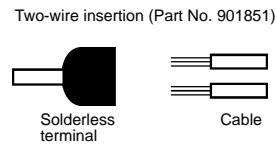
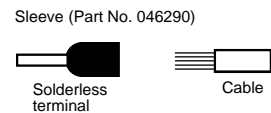

The following product is a dedicated tool.

- Manufacturer: Weidmuller  
PZ1.5 Crimper (Part No. 900599)

## Sensor Connector Pin Arrangement

SRT2-VID08S/VID08S-1      SRT2-VOD08S/VOD08S-1

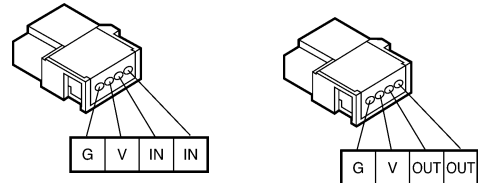

Model	Cable conductor size
XS8A-0441	0.3 to 0.5 mm <sup>2</sup>
XS8A-0442	0.14 to 0.2 mm <sup>2</sup>

**Note:** The XS8A-0441 or XS8A-0442 Connector is not provided with the SRT2-VID or SRT2-VOD. Place an order for the connector separately.

## Applicable Cables

Connectable product	Model	Applicable Cable
I/O Block	G7TC-OC16 G7TC-OC08 G7TC-ID16-5 G7TC-IA16-5 G7VC Series G70A Series G70D Series	G79-O50C (L = 500 mm)
		G79-O25C (L = 250 mm)
Connector-Terminal Conversion Unit	XW2B Series	↔
Digital Display Unit	M7F	
I/O Block	G7TC-ID16 G7TC-IA16 G7TC-OC16-1	G79-I50C (L = 500 mm)
		G79-I25C (L = 250 mm)

Calculate the cable conductor size as follows.

The following information is given on each sensor cable:

Cable dia. (Number of conductors/Conductor dia.)  
 Conductor size (mm<sup>2</sup>) =  
 (Conductor dia./2)<sup>2</sup> × π × Number of conductors

Example: E3S-A  
 4 dia. (18/0.12)  
 Conductor size (mm<sup>2</sup>) = (0.12/2)<sup>2</sup> × 3.14 × 18 ≈ 0.20

The conductor size is 0.2 mm<sup>2</sup>. Therefore, use the XS8A-0442.

## MIL Connector Pin Arrangement

SRT2-VID16ML/VID16ML-1

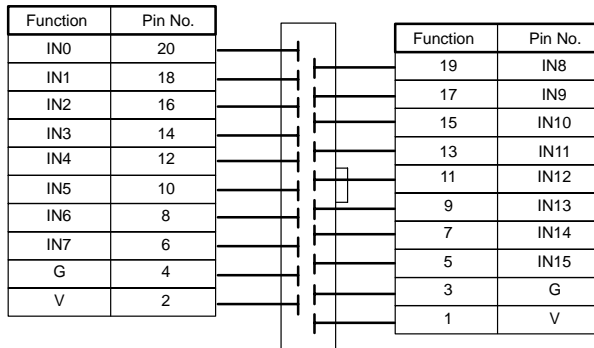

SRT2-VOD16ML/VOD16ML-1

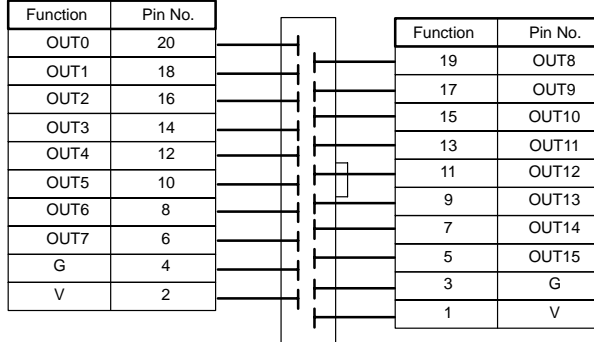

**Note:** 1. No cable connector is provided. Order the connector separately.

- Applicable Connector  
XG4M-2030-T
- Applicable Connector Cables  
G79-O50C  
G79-O25C  
G79-I50C  
G79-I25C

2. Refer to the following table for ordering information on the applicable Cables.

## Waterproof Terminals

SRT2-□D0□CL(-1)

### Eight Waterproof Terminal Models Emphasizing Cost Efficiency

- **Reduced Labor**  
Connection using connectors reduces the lead time required for installation. No tools are required for connection to a variety of devices.
- **Reduced Wiring**  
Signal line wiring has been reduced so that the Terminal can be mounted closer to sensors and other devices.
- **Relay Box not Required**  
Environment-resistant, dust-tight, drip-proof construction (IP67) enables direct on-site mounting.
- **Easier Maintenance**  
Significant reductions not only in setup time but also maintenance time.
- **Reduced Space, Improved Operability**  
Compact design (160 x 54 mm (W x H)) (8-point models)  
Settings and connections can be performed using the switch and connectors on the front side of the Terminal.



### ■ System Configuration

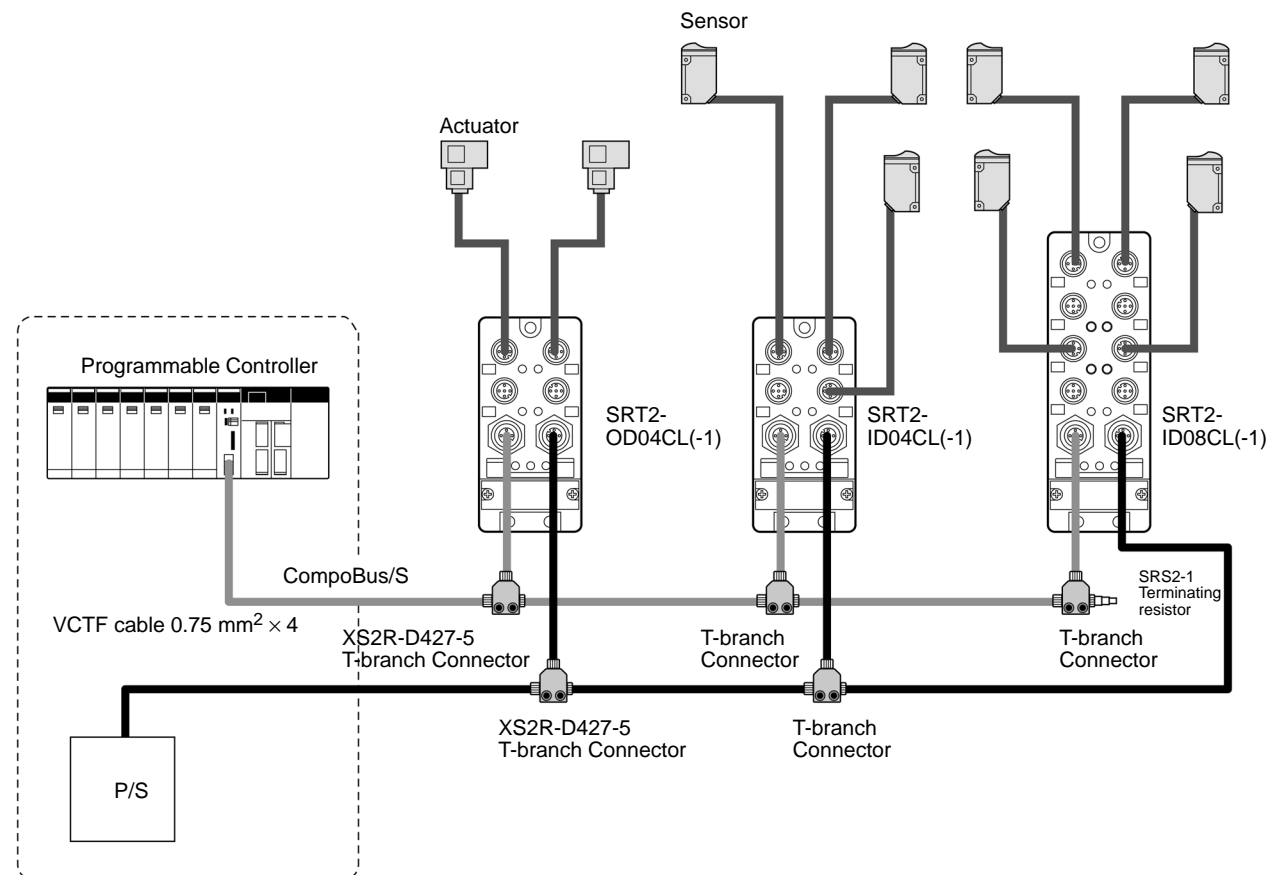

## Ordering Information

Input/Output	Internal I/O circuit common	I/O points	I/O connections method	Rated voltage for I/O power supply	Model
Inputs	NPN (+ common)	4 points	Sensor I/O connector	24 VDC	SRT2-ID04CL
		8 points			SRT2-ID08CL
	PNP (- common)	4 points			SRT2-ID04CL-1
		8 points			SRT2-ID08CL-1
Outputs	NPN (- common)	4 points			SRT2-OD04CL
		8 points			SRT2-OD08CL
	PNP (+ common)	4 points			SRT2-OD04CL-1
		8 points			SRT2-OD08CL-1

## Specifications

### ■ General Specifications

Item	SRT2-ID04CL SRT2-ID04CL-1 SRT2-OD04CL SRT2-OD04CL-1	SRT2-ID08CL SRT2-ID08CL-1 SRT2-OD08CL SRT2-OD08CL-1
Communications power supply voltage	14 to 26.4 VDC (supplied via communications connectors)	
I/O power supply voltage	20.4 to 26.4 VDC (24 VDC $-15\%/+10\%$ )	
Communications current consumption	15 mA max.	20 mA max.
Ambient temperature	Operating: $-10^{\circ}\text{C}$ to $55^{\circ}\text{C}$ (with no icing) Storage: $-25^{\circ}\text{C}$ to $65^{\circ}\text{C}$	
Ambient humidity	Operating: 25% to 85% (with no condensation) Storage: 25% to 85% (with no condensation)	
Connector tightening torque	0.39 to 0.49 N • m	
Enclosure rating	IEC IP67	
Mounting method	Mounted using M5 screws	
Weight	Approx. 180 g	Approx. 240 g

### ■ Communications Media/Distances

Communications medium	4-conductor cable (VCTF, 0.75 mm <sup>2</sup> x 4)	
Communications distance	High-speed Communications Mode	4-conductor VCTF cable: Main line length: 30 m max. Branch line length: 3 m max. Total branch line length: 30 m max. (When 4-conductor VCTF cable is used to connect fewer than 16 Slaves, the main line can be up to 100 m long and the total branch line length can be up to 50 m.)
	Long-distance Communications Mode	4-conductor VCTF cable: Variable branch wiring (total cable length 200 m max.) (There are no limits on the branching format or main, branch, or total line lengths. The terminator must be connected to the point in the system farthest from the master.)

**Note:** Use in combination with two-conductor VCTF cables and special flat cables is not possible.

■ Input Specifications

Item	SRT2-ID04CL SRT2-ID04CL-1	SRT2-ID08CL SRT2-ID08CL-1
Input current	For input voltage of 24 VDC: 6 mA max. per point For input voltage of 17 VDC: 3 mA min. per point	
Input impedance	4.4 kΩ	
ON delay time	1.5 ms max.	
OFF delay time	1.5 ms max.	
ON voltage	15 VDC min.	
OFF voltage	5 VDC max.	
OFF current	1 mA max.	
Number of circuits	4 points with 1 common	8 points with 1 common

■ Output Specifications

Item	SRT2-OD04CL SRT2-OD04CL-1	SRT2-OD08CL SRT2-OD08CL-1
Rated output current	0.5 A per point (2 A per common)	0.5 A per point (2.4 A per common)
Residual voltage	1.2 V max.	
Leakage current	0.1 mA max.	
ON delay time	0.5 ms max.	
OFF delay time	1.5 ms max.	
Number of circuits	4 points with 1 common	8 points with 1 common

■ Applicable Connectors

Power Supply Connectors

Model	Specification
XS2C-D4□□	Assembling-type connector (crimp, soldering, or screw) socket
XS2W-D42□-□□□-□	Cable with connector on each end
XS2F-D42□-□80-□	Cable with connector at one end (socket end)
XS2R-D427-5	T-branch connector

Communications Connector

Model	Specification
XS2R-D427-5	T-branch connector
SRS2-1	Connector with terminating resistor (plug)
XS2G-D4S7	Assembling-type connector (for 4-conductor VCTF cable) plug (See note.)
XS2C-D4S7	Assembling-type connector (for 4-conductor VCTF socket) socket (See note.)

**Note:** The XS2G-D4S7 and XS2C-D4S7 will be released soon.

I/O Connectors

Model	Specification
XS2G-D4□□	Assembling type connector (crimp, soldering, or screw) Socket
XS2H-D421-□□□-□	Cable with connector at one end (plug end)
XS2W-D42□-□□□-□	Cable with connector on each end
XS2Z-12	Waterproof cover
XS2Z-15	Dust cover

Assembling-type Connector Socket  
Power Supply and Communications

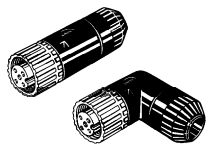
Model	Applicable cable external dia.	Cable pull-out direction	No. of poles	Connection method		
				Crimp	Solder	Screw
	6 dia. (5 to 6 dia.)	Straight	4	XS2C-D4C1	XS2C-D421	XS2C-D4S1
		L-shaped		XS2C-D4C2	XS2C-D422	XS2C-D4S2
	5 dia. (4 to 5 dia.)	Straight		XS2C-D4C3	XS2C-D423	XS2C-D4S3
		L-shaped		XS2C-D4C4	XS2C-D424	XS2C-D4S4
	3 dia. (3 to 4 dia.)	Straight		XS2C-D4C5	XS2C-D425	XS2C-D4S5
		L-shaped		XS2C-D4C6	XS2C-D426	XS2C-D4S6
	7 dia. (7 to 8 dia.)	Straight		---	---	XS2C-D4S7 (see note)

**Note:** Only the XS2C-D4S7 with a diameter of 7 mm can be used for communications.

Assembling-type Connector Plug

**Power Supply and Communications**

Appearance	Applicable cable external dia.	Cable pull-out direction	No. of poles	Connection method		
				Crimp	Solder	Screw
	6 dia. (5 to 6 dia.)	Straight	4	XS2G-D4C1	XS2G-D421	XS2G-D4S1
		L-shaped		---	XS2G-D422	XS2G-D4S2
	5 dia. (4 to 5 dia.)	Straight		XS2G-D4C3	XS2G-D423	XS2G-D4S3
		L-shaped		---	XS2G-D424	XS2G-D4S4
	3 dia. (3 to 4 dia.)	Straight		XS2G-D4C5	XS2G-D425	XS2G-D4S5
		L-shaped		---	XS2G-D426	XS2G-D4S6
	7 dia.	Straight		---	---	XS2G-D4S7 (see note)

**Note:** Only the XS2G-D4S7 with a diameter of 7 mm can be used for communications.

**Connectors with Cables (Single-end Socket Each)**  
**Power Supply**

Appearance	Cable pull-out direction	No. of cable conductor	Cable length (m)	Standard cable	Robot cable (vibration resistive)
	Straight	4	1	XS2F-D421-C80-A	XS2F-D421-C80-R
			2	XS2F-D421-D80-A	XS2F-D421-D80-R
			5	XS2F-D421-G80-A	XS2F-D421-G80-R
			10	XS2F-D421-J80-A	XS2F-D421-J80-R
	L-shaped		1	XS2F-D422-C80-A	XS2F-D422-C80-R
			2	XS2F-D422-D80-A	XS2F-D422-D80-R
			5	XS2F-D422-G80-A	XS2F-D422-G80-R
			10	XS2F-D422-J80-A	XS2F-D422-J80-R

**Connectors with Cables (Sockets and Plugs)**  
**Power Supply and I/O**

Appearance	Cable pull-out direction	No. of cable conductor	Cable length (m)	Standard cable	Robot cable (vibration resistive)
	Straight/Straight	4	1	XS2W-D421-C81-A	XS2W-D421-C81-R
			2	XS2W-D421-D81-A	XS2W-D421-D81-R
			5	XS2W-D421-G81-A	XS2W-D421-G81-R
	L-shaped/L-shaped		2	XS2W-D422-D81-A	---
			5	XS2W-D422-G81-A	---
	Straight/L-shaped		2	XS2W-D423-D81-A	---
			5	XS2W-D423-G81-A	---
	L-shaped/Straight		2	XS2W-D424-D81-A	---
			5	XS2W-D424-G81-A	---

**Connectors with Cables (Single-end Connector Each)**  
**I/O**

Appearance	Cable pull-out direction	No. of cable conductor	Cable length (m)	Standard cable
	Straight	3	0.3	XS2H-D421-AC0-A
		4		XS2H-D421-A80-A
		3	1	XS2H-D421-CC0-A
		4		XS2H-D421-C80-A

**Connector Covers**

Appearance	Product	Model	Application
	T-branch Connector	XS2R-D427-5	Branching communications lines and power lines
	Connector Terminator (plug)	SRS2-1	Waterproof terminator
	Waterproof cover	XS2Z-12	Covers for unused I/O connectors
	Dust cover	XS2Z-15	



## Dimensions

**Note:** All units are in millimeters unless otherwise indicated.

### Models with 4 points

SRT2-ID04CL/SRT2-ID04CL-1  
SRT2-OD04CL/SRT2-OD04CL-1

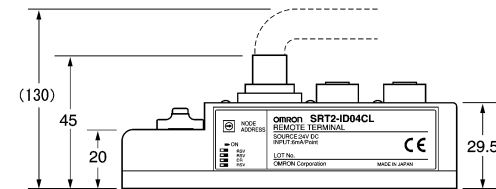
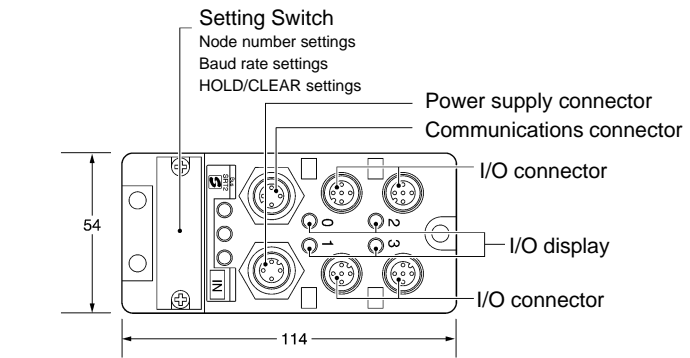

#### Mounting Dimensions

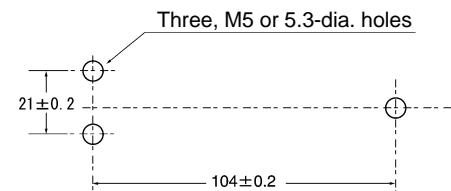

### Models with 8 points

SRT2-ID08CL/SRT2-ID08CL-1  
SRT2-OD08CL/SRT2-OD08CL-1

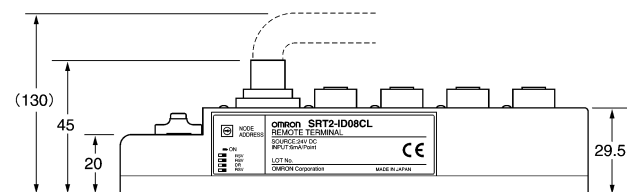
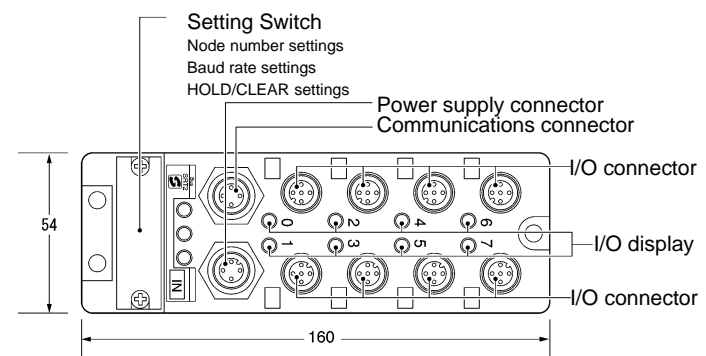

#### Mounting Dimensions

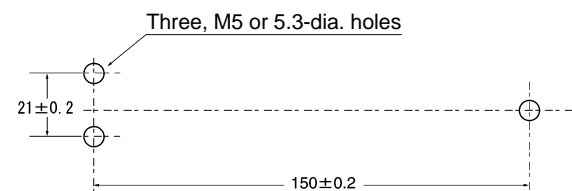

# Installation

## Internal Circuit Diagrams

SRT2-ID0□CL (NPN)

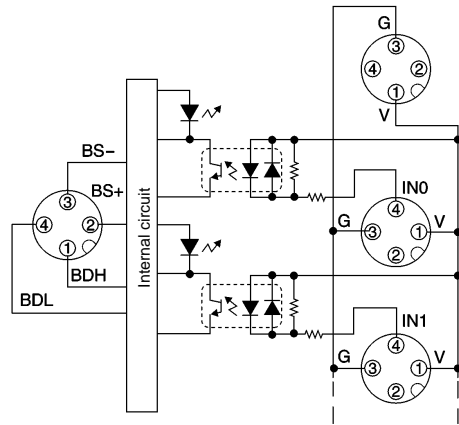

SRT2-ID0□CL-1 (PNP)

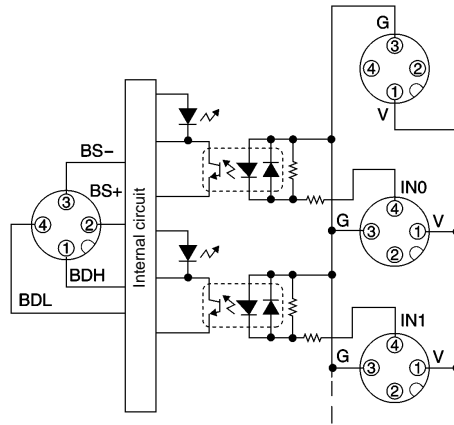

SRT2-OD0□CL (NPN)

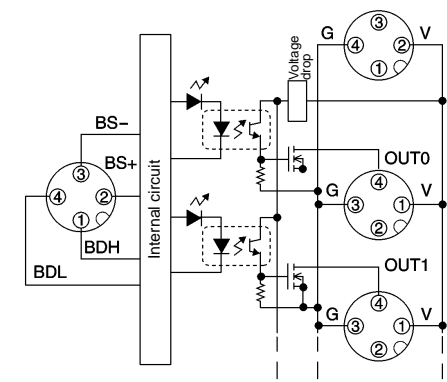

SRT2-OD0□CL-1 (PNP)

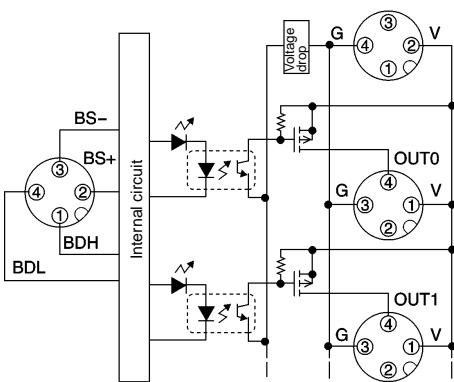

## Connections Diagrams for Connectors

Communications Connector

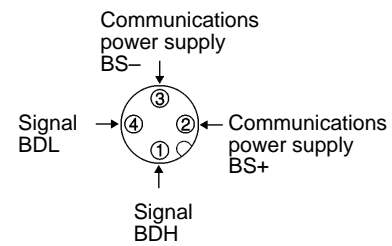

ID0□(-1) Power Supply Connector

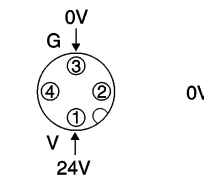

OD0□(-1) Power Supply Connector

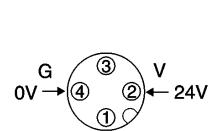

ID0□ Input Connector (NPN)

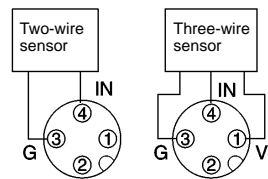

ID0□-1 Input Connector (PNP)

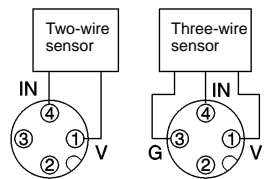

OD0□ Output Connector (NPN)

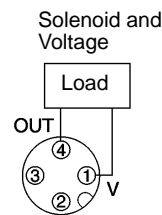

OD0□ Output Connector (PNP)

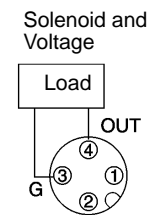

#### Connector Connection Models that Allows Easy Connection to Sensors and Output Devices

- Sensors with easy-to-wire connectors are easily attached or detached.
- Connects to 2-wire sensors.
- Remote teaching of the Sensor Terminal is possible with the PLC by using output signals of the Sensor Terminal.
- DIN track mounting and screw mounting are available.

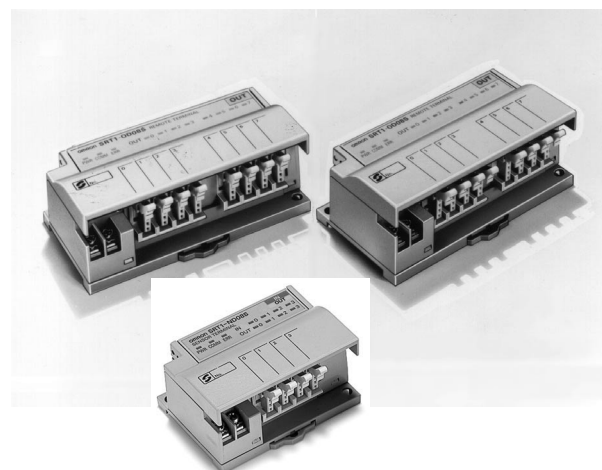

#### Ordering Information

Classification	Internal I/O circuit common	I/O points	Model
For input	NPN (– common)	8 input points	SRT2-ID08S
For I/O	NPN (– common)	4 input/4 output points	SRT2-ND08S
For output	NPN (– common)	8 output points	SRT2-OD08S

#### Specifications

##### ■ Ratings

##### Input

Item	SRT2-ID08S/-ND08S
Input current	10 mA max./point
ON delay time	1 ms max.
OFF delay time	1.5 ms max.
ON voltage	12 VDC min. between each input terminal and $V_{CC}$ , the external sensor power supply
OFF voltage	4 VDC max. between each input terminal and $V_{CC}$ , the external sensor power supply
OFF current	1 mA max.
Insulation method	Photocoupler
Input indicator	LED (yellow)

##### Output

Item	SRT2-ND08S	SRT2-OD08S
Rated output current	20 mA/point	300 mA/point
Residual voltage	1 V max.	0.6 V max.
ON delay time	1 ms max.	---
OFF delay time	1.5 ms max.	---
Leakage current	0.1 mA max.	
Insulation method	Photocoupler	
Output indicator	LED (yellow)	

## ■ Characteristics

Communications power supply voltage (see note 1)	14 to 26.4 VDC
Current consumption (see note 2)	50 mA max. at 24 VDC
Connection method	Multi-drop method and T-branch method
Dielectric strength	500 VAC for 1 min (1-mA sensing current between insulated circuits)
Noise immunity	Conforms to IEC61000-4-4 2kV (power lines)
Vibration resistance	10 to 55 Hz, 1.5-mm double amplitude
Shock resistance	Malfunction: 200 m/s <sup>2</sup> Destruction: 300 m/s <sup>2</sup>
Mounting method	M4 screw mounting or 35-mm DIN track mounting
Mounting strength	No damage when 50 N pull load was applied for 10 s in all directions (except the DIN track directions and a pulling force of 10 N)
Terminal strength	No damage when 50 N pull load was applied for 10 s in all directions Tighten each screw to a torque of 0.6 to 1.18 N • m
Ambient temperature	Operating: 0°C to 55°C (with no icing or condensation) Storage: -20°C to 65°C (with no icing or condensation)
Ambient humidity	Operating: 35% to 85%
Weight	SRT2-ID08S/OD08S: 100 g max., SRT2-ND08S: 80 g max.

**Note:** 1. The communications power supply voltage must be 20.4 to 26.4 VDC if the Unit is connected to 2-wire proximity sensors.  
2. The above current consumption is a value with all the points turned OFF excluding the current consumption of the sensor connected to the Sensor Terminal.

## ■ External Sensor Power Supply

Power supply voltage	13.5 to 26.4 VDC
Current consumption	500 mA max. in total

## Nomenclature

SRT2-ID08S  
SRT2-ND08S

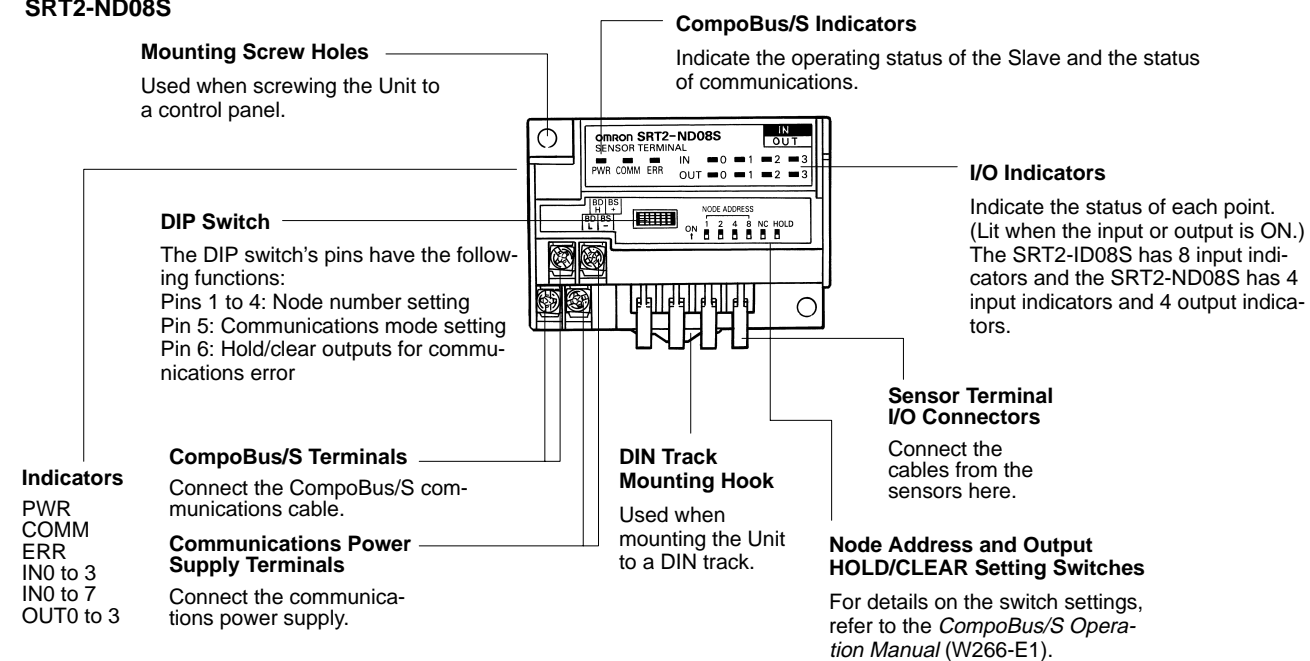

**Indicators**

Indicator	Name	Display	Color	Meaning
PWR	Power supply	Lit	Green	The communications power supply is ON.
		Not lit		The communications power supply is OFF.
COMM	Communication	Lit	Yellow	Normal communications
		Not lit		A communications error has occurred or the Unit is in standby status.
ERR	Communication error	Lit	Red	A communications error has occurred.
		Not lit		Normal communications or the Unit is in standby status.
0 to 3 (4 inputs/outputs) 0 to 7 (8 inputs)	Input	Lit	Yellow	The corresponding input is ON.
		Not lit		The corresponding input is OFF or the Unit is in standby status.
0 to 3 (4 inputs/outputs)	Output	Lit	Yellow	The corresponding output is ON.
		Not lit		The corresponding output is OFF or the Unit is in standby status.

**Switch Setting**

All pins are factory-set to OFF.



Node number settings  
 Hold/Clear outputs when communications error occurs (SRT2-ND08S only)  
 Communications mode setting

**Pin 5 (Communications Mode Setting)**

Pin 5	Communications mode
OFF	High-speed communications mode
ON	Long-distance communications mode

**Pin 6 (Output HOLD/CLEAR Mode)  
(SRT2-ND08S Only)**

HOLD	Function
OFF	Output status is cleared when a communications error occurs.
ON	Output status is maintained when a communications error occurs.

**Node Number Settings**

Node number	1	2	4	8
0	OFF	OFF	OFF	OFF
1	ON	OFF	OFF	OFF
2	OFF	ON	OFF	OFF
3	ON	ON	OFF	OFF
4	OFF	OFF	ON	OFF
5	ON	OFF	ON	OFF
6	OFF	ON	ON	OFF
7	ON	ON	ON	OFF
8	OFF	OFF	OFF	ON
9	ON	OFF	OFF	ON
10	OFF	ON	OFF	ON
11	ON	ON	OFF	ON
12	OFF	OFF	ON	ON
13	ON	OFF	ON	ON
14	OFF	ON	ON	ON
15	ON	ON	ON	ON

SRT2-OD08S

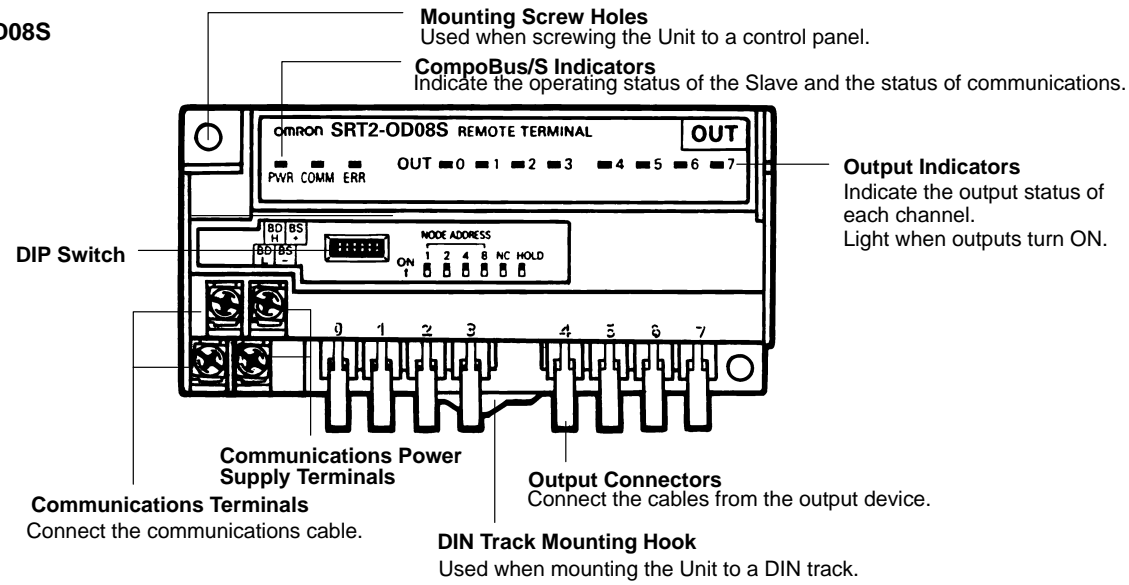

**Indicators**

Indicator	Name	Display	Color	Meaning
PWR	Power supply	Lit	Green	The communications power supply is ON.
		Not lit		The communications power supply is OFF.
COMM	Communication	Lit	Yellow	Normal communications
		Not lit		A communications error has occurred or the Unit is in standby status.
ERR	Communication error	Lit	Red	A communications error has occurred.
		Not lit		Normal communications or the Unit is in standby status.
OUT0 to 7	Output	Lit	Yellow	The corresponding output is ON.
		Not lit		The corresponding output is OFF or the Unit is in standby status.

**Switch Setting**

All pins are factory-set to OFF.

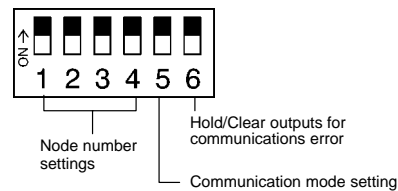

**Pin 5 (Communications Mode Setting)**

Pin 5	Communications mode
OFF	High-speed communications mode
ON	Long-distance communications mode

**Pin 6 (Output HOLD/CLEAR Mode)**

HOLD	Function
OFF	Output status is cleared when a communications error occurs.
ON	Output status is maintained when a communications error occurs.

**Node Number Settings**

Node number	4	3	2	1
0	OFF	OFF	OFF	OFF
1	OFF	OFF	OFF	ON
2	OFF	OFF	ON	OFF
3	OFF	OFF	ON	ON
4	OFF	ON	OFF	OFF
5	OFF	ON	OFF	ON
6	OFF	ON	ON	OFF
7	OFF	ON	ON	ON
8	ON	OFF	OFF	OFF
9	ON	OFF	OFF	ON
10	ON	OFF	ON	OFF
11	ON	OFF	ON	ON
12	ON	ON	OFF	OFF
13	ON	ON	OFF	ON
14	ON	ON	ON	OFF
15	ON	ON	ON	ON

## Dimensions

Note: All units are in millimeters unless otherwise indicated.

### SRT2-ID08S

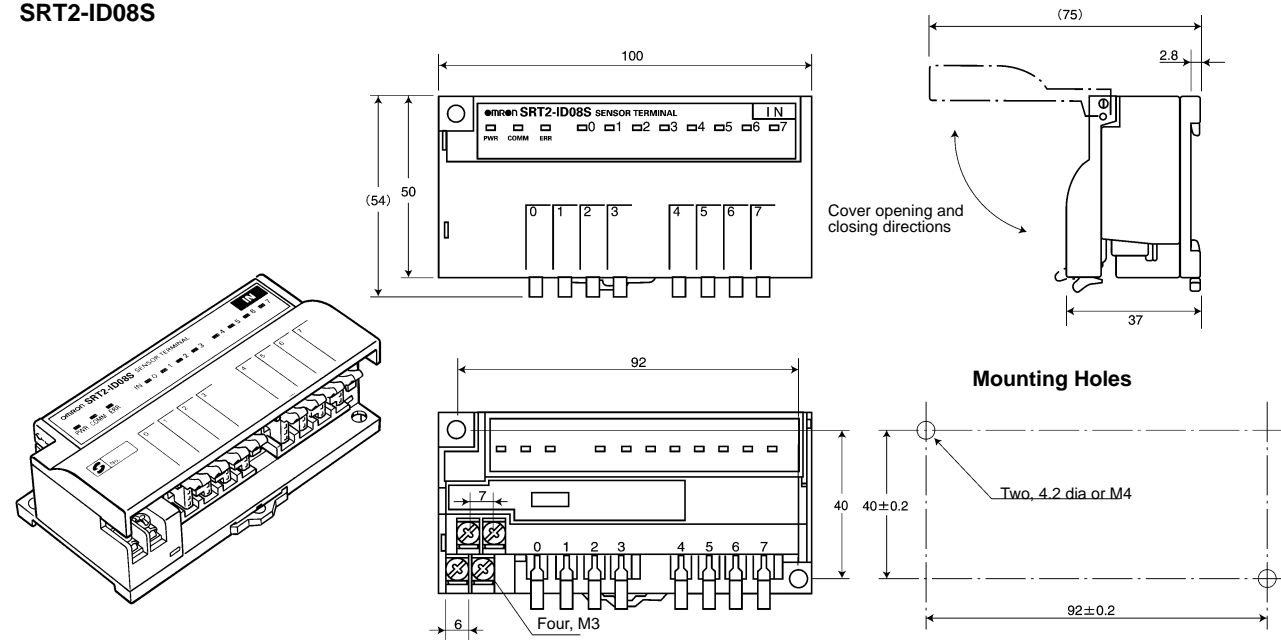

### SRT2-ND08S

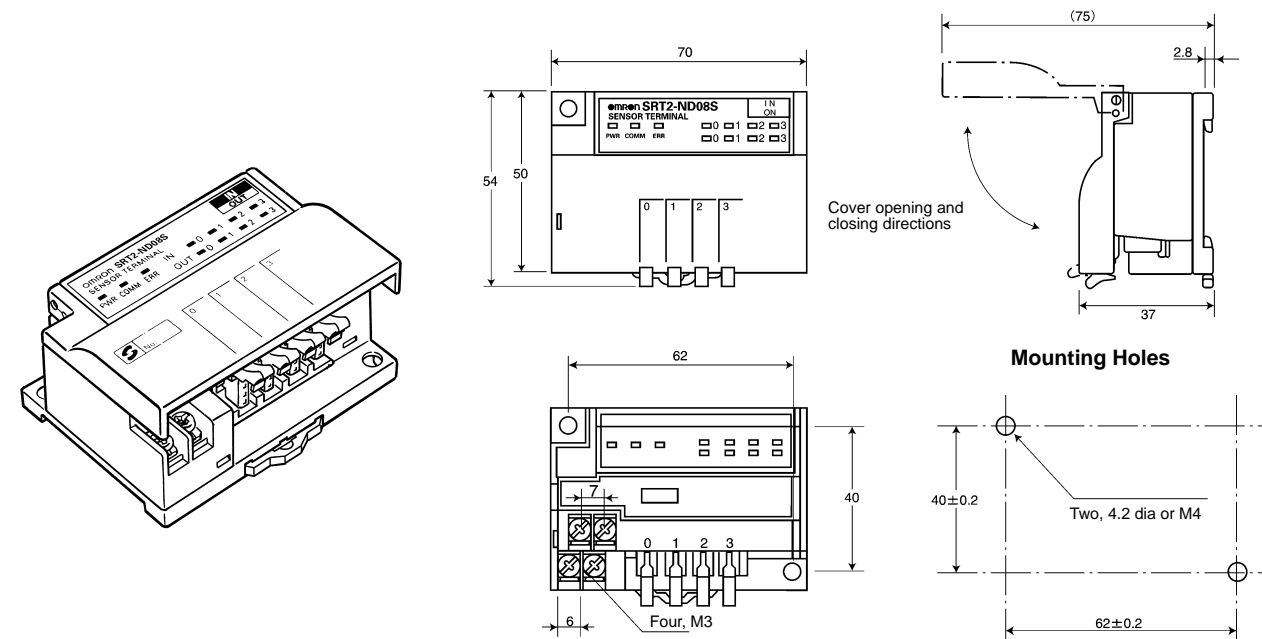

SRT2-OD08S

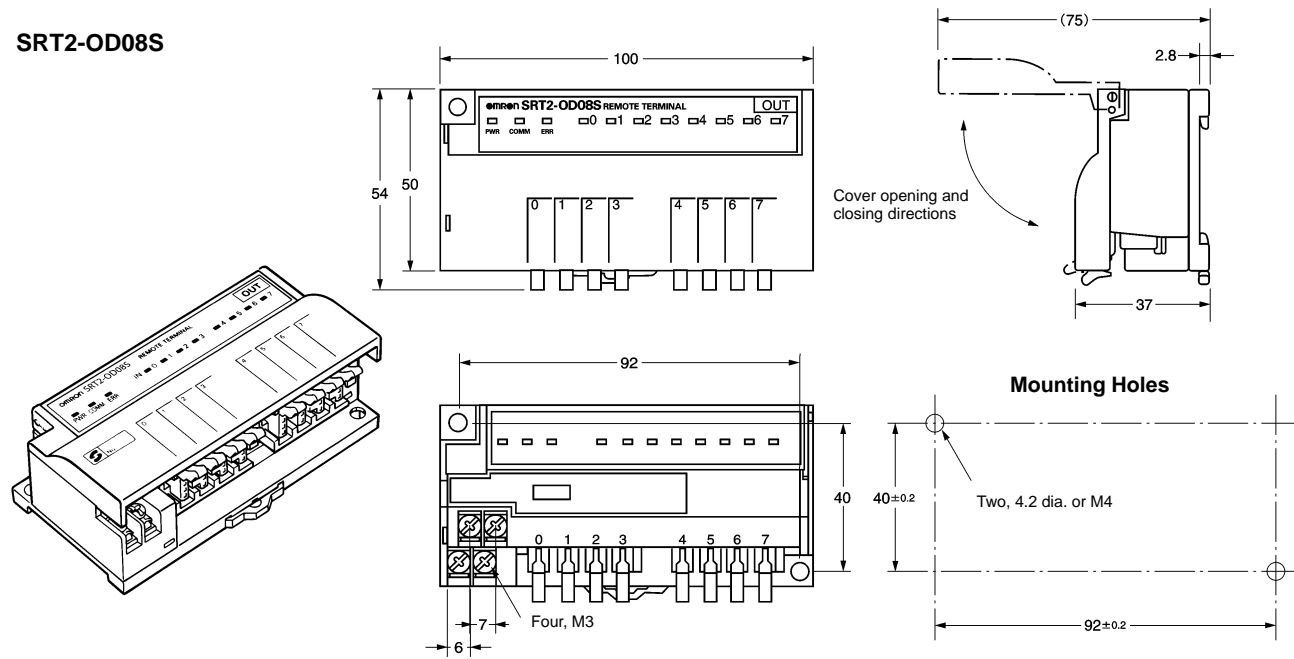

Cable Connector for SRT2-□D08S

Applicable conductor size (mm <sup>2</sup> )	Model
0.3 to 0.5	XS8A-0441
0.14 to 0.2	XS8A-0442
0.3 to 0.5	XS8B-0443

XS8A-044□  
(Cable Connector)

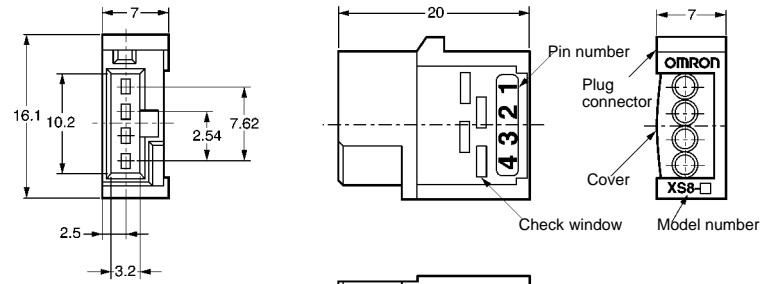

XS8B-0443  
(Relay Socket)

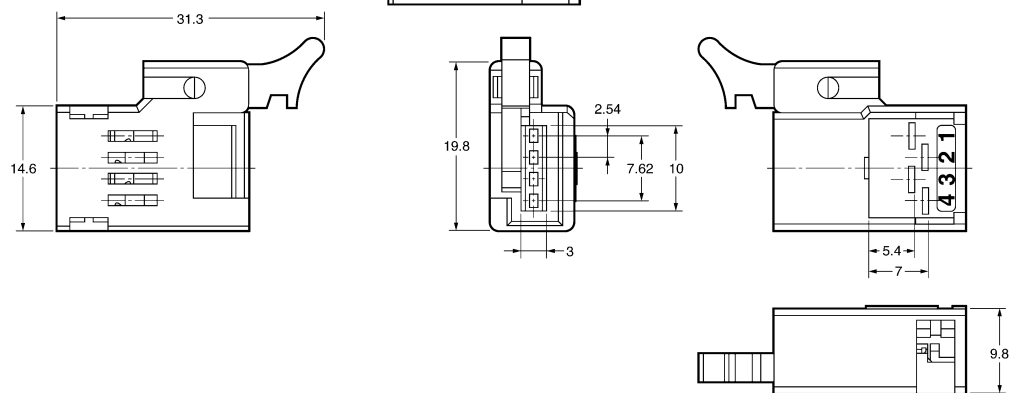

Calculate the cable conductor size as explained below.

The following information is given on each sensor cable:

Cable dia. (Number of conductors/Conductor dia.)

Conductor size (mm<sup>2</sup>) = (Conductor dia./2)<sup>2</sup> × π × Number of conductors

Example: E3S-A

4 dia. (18/0.12)

Conductor size (mm<sup>2</sup>) = (0.12/2)<sup>2</sup> × 3.14 × 18 ≈ 0.20

The conductor size is 0.2 mm<sup>2</sup>. Therefore, use the XS8A-0442.



# Installation

## Internal Circuit Configuration

SRT2-ID08S

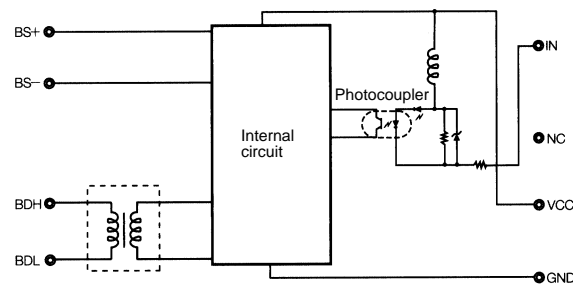

SRT2-ND08S

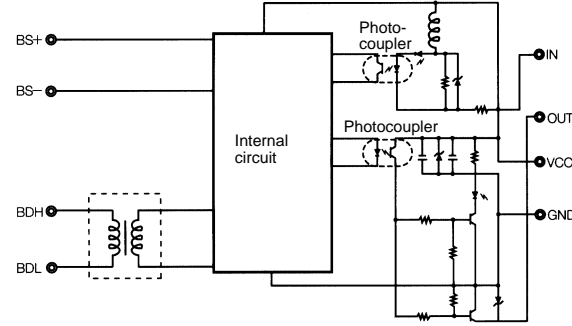

SRT2-OD08S

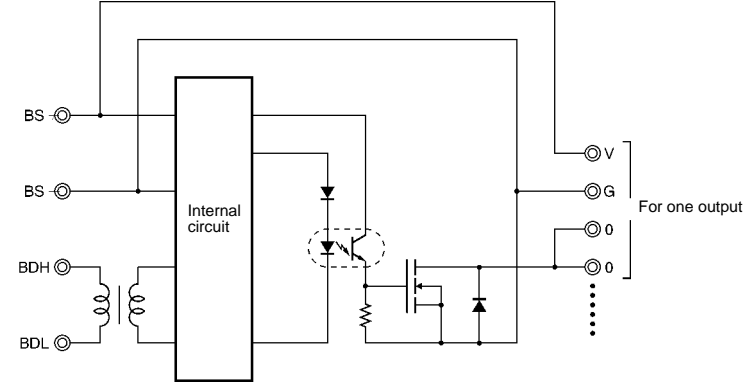

## External Connections

SRT2-ID08S

Three-wire Sensor    Two-wire Sensor

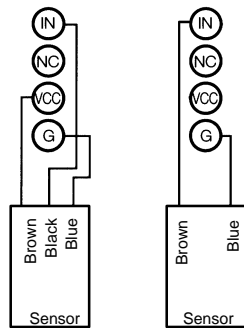

SRT2-ND08S

Sensor with Teaching Function  
Sensor with External Diagnostic function  
Sensor with Bank-switching Function

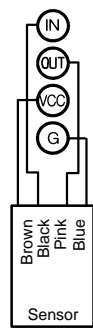

Three-wire Sensor

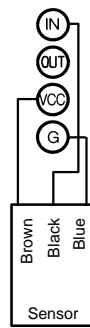

Two-wire Sensor

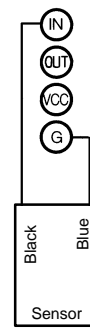

SRT2-OD08S

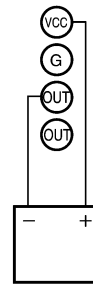

Valve, solenoid

## ■ Terminal Arrangement and I/O Device Connection Example

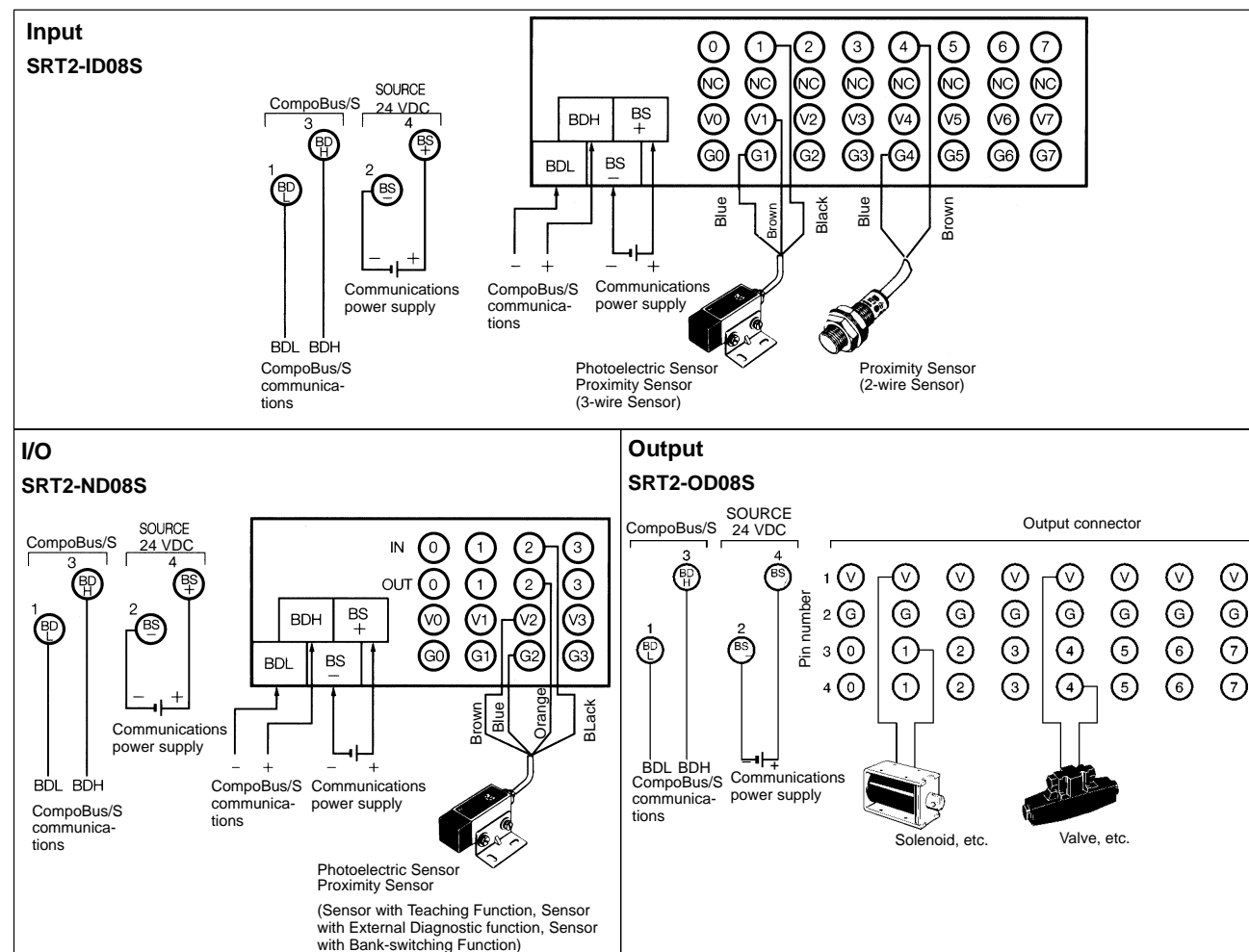

## Precautions

Refer to the *CompoBus/S Operation Manual (W266-E1)* before using the Unit.

### General Safety Precautions

#### Installation Environment

Do not install the Unit in the following places.

- Places with water, oil, or chemical sprayed on the Unit.
- Places with rapid temperature changes.
- Places with high humidity resulting in condensation.
- Places with intense electric and magnetic fields.
- Places with excessive vibration or shock.

#### Wiring

To prevent inductive noise, do not wire power lines or high-tension lines along with or near the cables.

Make sure that the polarity of each terminal is correct.

Make sure that the communications path and power line are connected correctly.

Secure the cables properly. Do not pull the cables with strong force, otherwise the cables may be disconnected from the terminals or connectors of the Unit.

Do not touch the Unit when the Unit is used in places with high ambient temperatures because the surface temperature of the Unit may be high.

Do not use paint thinner to clean the surface of the Unit, otherwise the surface will be damaged or discolored.

### Correct Use

Use the Unit under its rated conditions.

Mount the Unit with M4 screws or to DIN tracks securely.

### Typical Causes of Communications Errors

- The cables are not connected correctly.
- The node number setting is incorrect.
- The baud rate setting is incorrect.
- There is a strong noise source, such as an inverter motor, near the Unit. Install the Unit as far as possible from the noise source or shield the noise source.

### Others

Use OMRON's XS8A-0441 or XS8A-0442 Connectors with the Unit.

Insert each connector into the Unit until the connector snaps in place. Make sure that terminal number 1 of the connector is on the lock lever side when inserting the connector.

Refer to the *CompoBus/S Operation Manual (W266-E1)* for wiring the Unit.

### Snap On to Connect and Save Wiring Effort

- The 4-channel fiber photoelectric amplifiers in Terminals with connectors offer a low cost and space savings.
- Connection of miniature and aluminum-detecting proximity sensors is supported.
- The product lineup included Terminal Block Units for easy connection to sensors with amplifiers, limit switches, etc.
- Connect to up to eight channels of sensors by using Expansion Blocks.

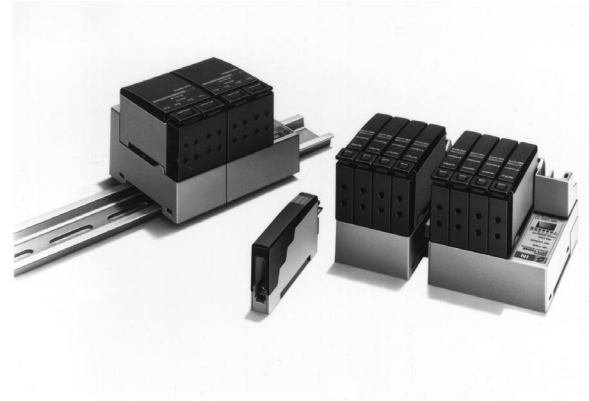

### ■ Features

#### Low Cost and Space Savings with 4-channel Amplifier Units

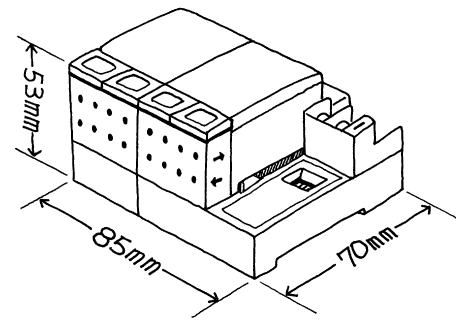

#### Just Snap On to Connect

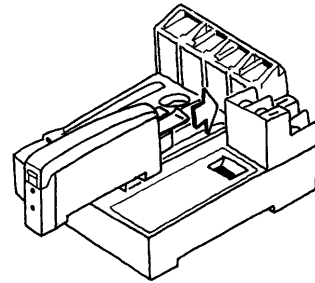

#### Connection Units

Photoelectric Sensors  
One-channel Sensors

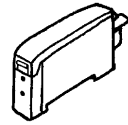

Proximity Sensors  
E2CY Models (Amplifier Unit)

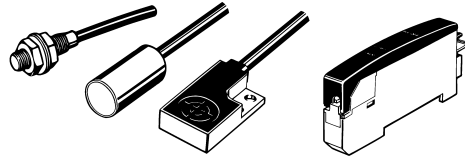

Terminal Block Unit

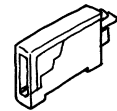

↓ Various input devices can be connected.

Four-channel Sensors

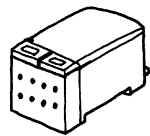

E2C-T Models (Amplifier Unit)

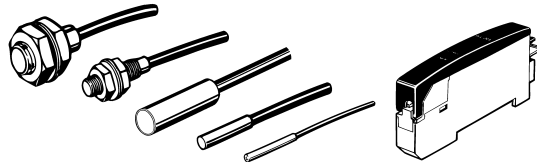

Photoelectric Sensor

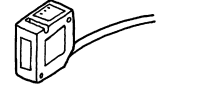

Proximity Sensor



Basic Switch and  
Limit Switch



## Ordering Information

### CompoBus/S Sensor Amplifier Terminals

Classification	I/O points	Connection Unit	Model
Communications	4	E3X-NT□/E3X-DA□/E2C□-T1 6/E39-JID01 (4 Units max.)	SRT1-TID04S
		E3X-NM16 (1 Unit max.)	SRT1-TKD04S
Expansion		E3X-NT□/E3X-DA16/E2C□-T1 6/E39-JID01 (4 Units max.)	SRT1-XID04S
		E3X-NM16 (1 Unit max.)	SRT1-XKD04S

**Note:** Long-distance communications mode is not supported.

### Connection Units

Classification	Specifications	Model	
Photoelectric Sensor	Models with E3X-N-type connector	General-purpose, 1 channel	E3X-NT16
		Multi-functional, 1 channel	E3X-NT26
		Long distance, high accuracy, 1 channel	E3X-NH16
		Multi-functional, 4 channels	E3X-NM16
	Models with E3X-DA-type connector	Digital, general-purpose, 1 channel	E3X-DA16
Proximity Sensor	Models with E2CY-type connector	Used to detect aluminum	E2CY-T16
	Models with E2C-T-type connector	Miniature	E2C-T16
Terminal Block Unit	One input point	E39-JID01	

## Specifications

### ■ Characteristics

#### CompoBus/S Sensor Amplifier Terminals

Item	Communication Terminals	Expansion Terminals
<b>Model</b>	SRT1-TID04S    SRT1-TKD04S	SRT1-XID04S    SRT1-XKD04S
<b>Communications power supply voltage</b>	14 to 26.4 VDC (See note 1)	
<b>I/O points</b>	4 input points	
<b>Connected Sensors</b>	Total of four E3X-NT□6, E3X-NH16, E3X-DA16, E2C□-T16, or E39-JID01 (See note 2)	One E3X-NM16 (See note 2)
<b>Current consumption</b>	60 mA max. (See note 3)	10 mA max. (See note 3)
<b>Dielectric strength</b>	500 VAC for 1 min (1-mA sensing current between insulated circuits)	
<b>Noise immunity</b>	Power supply normal: ±600 V for 10 minutes with a pulse width of 100 ns to 1 μs Power supply common: ±1,500 V for 10 minutes with a pulse width of 100 ns to 1 μs	
<b>Vibration resistance</b>	10 to 55 Hz, 1.5-mm double amplitude	
<b>Shock resistance</b>	Malfunction: 200 m/s <sup>2</sup> Destruction: 300 m/s <sup>2</sup>	
<b>Mounting method</b>	M4 screw mounting or 35-mm DIN track mounting	
<b>Mounting strength</b>	No damage when 50 N pull load was applied for 10 s in all directions (except the DIN track directions and a pulling force of 10 N)	
<b>Terminal strength</b>	No damage when 49 N pull load was applied for 10 s in all directions. Tighten each screw to a torque of 0.6 to 1.18 N • m.	
<b>Ambient temperature</b>	Operating: 0°C to 55°C (with no icing or condensation) Storage: -20°C to 65°C (with no icing or condensation)	
<b>Ambient humidity</b>	Operating: 35% to 85%	
<b>Weight</b>	70 g max.    65 g max.	45 g max.    35 g max.

- Note:**
1. The communications power supply voltage must be 20.4 to 26.4 VDC if the Terminal is connected to 2-wire proximity sensors.
  2. When adding Connection Units, use SRT1-XID04S or SRT1-XKD04S.
  3. The value does not include the current consumption of Connection Units.

**E3X-DA/N Models**

Model	E3X-DA16	E3X-NH16	E3X-NT16	E3X-NT26	E3X-NM16
<b>Current consumption</b>	75 mA max.		50 mA max.		150 mA
<b>Response time</b>	High-speed mode: 0.25 ms (operate/release) Standard mode: 1 ms (operate/release) Long-distance mode: 4 ms (operate/release) 4.0 ms max. when connected to the SRT1-□□D04S (standard mode)	1 ms max. (4.0 ms max. when connected to the SRT1-□□D04S)	500 μS max. (2.0 ms max. when connected to the SRT1-□□D04S)		
<b>Timer function</b>	OFF-delay timer (settable in the range 0 to 200 ms in 5-ms units)	Not available		OFF-delay timer (fixed to 40 ms)	
<b>Remote teaching input</b>	Not available			Available (Remote teaching disabled)	
<b>Indicator</b>	Operation indicator (orange), 7-segment digital incident level display (red), 7-segment digital incident level percentage display (red), incident level and threshold 2-color indication bar (green and red), 7-segment digital threshold display (red)	Operation indicator (orange) 8-level incident level indicator (green) 13-level threshold indicator (red)			
<b>Teaching confirmation function</b>	Indicators (red/green LED) and buzzer				
<b>Output</b>	Light ON and Dark ON switch selectable				
<b>Ambient illumination</b>	Sunlight: 20,000 lux max.; incandescent lamp: 10,000 lux max.	Sunlight: 10,000 lux max.; incandescent lamp: 3,000 lux max.			
<b>Insulation resistance</b>	20 MΩ max. (at 500 VDC)				
<b>Dielectric strength</b>	1,000 VAC at 50/60 Hz for 1 min				
<b>Vibration resistance</b>	Destruction: 10 to 55 Hz, 1.5-mm double amplitude				
<b>Shock resistance</b>	Destruction: 500 m/s <sup>2</sup> 3 times each in X, Y, and Z directions				
<b>Mounting method</b>	Connected to the SRT1-□□D04S using connectors.				
<b>Mounting strength</b>	No damage when 49 N pull load was applied for 10 s in all directions.				
<b>Ambient temperature</b>	Operating: -25°C to 55°C (with no icing or condensation) Storage: -30°C to 70°C (with no icing or condensation)	Operating: -25°C to 55°C (with no icing or condensation) Storage: -40°C to 70°C (with no icing or condensation)			
<b>Ambient humidity</b>	Operating: 35% to 85% (with no condensation) Storage: 35% to 85% (with no condensation)				
<b>Weight</b>	60 g max.	30 g max.	30 g max.	30 g max.	60 g max.

**E2CY Models (Amplifier Unit)**

<b>Supply voltage</b>	12 to 24 VDC ± 10%, ripple (p-p): 10% max.
<b>Current consumption</b>	40 mA max.
<b>Sensing distance adjustment range</b>	10% min. of stable sensing distance
<b>Adjustment method</b>	Teaching
<b>Differential travel</b>	10% max. of sensing distance in FINE mode. 15% max. of sensing distance in NORM mode.
<b>Response time</b>	Refer to the response frequency of the Sensor Head in use.
<b>Control output</b>	NPN open collector output of 100 mA max. with a max. residual voltage of 1 V
<b>Self-diagnostic output</b>	NPN open collector output of 100 mA max. with a max. residual voltage of 1 V
<b>Circuit protection</b>	Reverse polarity, surge voltage, and load short-circuit (for both control output and diagnosis output)
<b>Cord length compensation</b>	Freely cut or extended within a range between 0.5 and 5 m
<b>Indicators</b>	Operation indicator (orange) Excess gain level indicators (ON in green with sensing object in proximity and ON in orange with no sensing object in proximity) Fine-tuning indicator (green)
<b>Ambient temperature</b>	Operating: -10 to 55°C (with no icing or condensation)
<b>Ambient humidity</b>	Operating: 35% to 85% (with no condensation)
<b>Influence of temperature on sensing distance (at 23°C)</b>	±10% max. (-10°C to 55°C)
<b>Insulation resistance</b>	50 MΩ min. (at 500 VDC) between current carry parts and case
<b>Dielectric strength</b>	1,000 VAC (50/60 Hz) for 1 min between current carry parts and case
<b>Vibration resistance</b>	Destruction: 10 to 150 Hz, 1.5-mm double amplitude or 100 m/s <sup>2</sup> for 2 hours each in X, Y, and Z directions
<b>Shock resistance</b>	Destruction: 300 m/s <sup>2</sup> for 3 hours each in X, Y, and Z directions
<b>Mounting method</b>	Connected to the SRT1-□□D04S using connectors.
<b>Mounting strength</b>	No damage when 49 N pull load was applied for 10 s in all directions.
<b>Degree of protection</b>	IEC60529 IP50 with the sensor cord and protective cover attached
<b>Material</b>	Case: PTB resin Cover: PC
<b>Teaching monitor function</b>	Orange and green indicators shared by operation and excess gain indication
<b>Output status</b>	Normally open or normally closed selectable
<b>Weight (packaged state)</b>	Approx. 30 g

**E2C-T Models (Amplifier Unit)**

Item	Sensor Head				
	E2C-CR5B2	E2C-CR8A E2C-CR8B	E2C-X1A E2C-C1A	E2C-X1R5A	
Supply voltage	12 to 24 VDC ± 10% (operation: 10 to 26.4 VDC), ripple (p-p): ±10% max.				
Current consumption	50 mA max.				
Sensing distance adjustment range (see note 1)	Setting distance for teaching without sensing object (see note 2)	0.4 mm min.	0.72 mm min.	0.9 mm min.	1.35 mm min.
	Setting distance for teaching with and without sensing object or positioning teaching	0 to 40°C 0 to 55°C	0.1 to 0.7 mm 0.1 to 0.5 mm	0.16 to 1.2 mm 0.16 to 0.8 mm	0.2 to 1.5 mm 0.2 to 1.0 m
Temperature influence	±25% max. of sensing distance at 23°C (0 to 55°C)		±10% max. of sensing distance at 23°C (0 to 55°C)		
Differential travel	15% max. of sensing distance		10% max. of sensing distance		
Response time	Refer to the response frequency of the Proximity Sensor in use.				
Control output	NPN open collector output of 100 mA max. at 26.4 V with a residual voltage of 1 V max. NO/NC selectable (NO: ON with a sensing object)				
Cord length compensation	3 m only		1, 2, or 3 m selectable		
Indicators	Operation indicator (orange) and stability indicator (green)				
Teaching monitor function	Indicators (orange and green) also used for stability indication.				
Ambient temperature	Operating: 0 to 55°C (with no icing or condensation)				
Ambient humidity	Operating: 35% to 95% (with no icing)				
Voltage influence	±1% max. of sensing distance within a range of 90% to 110% of the rated power supply voltage				
Insulation resistance	50 MΩ min. at 500 VDC between current carry parts and case				
Dielectric strength	1,000 VAC (50/60 Hz) for 1 min between current carry parts and case				
Vibration resistance	Destruction: 10 to 55 Hz, 1.5-mm double amplitude for 2 hours each in X, Y, and Z directions				
Mounting method	Connected to the SRT1-□□D04S using connectors.				
Mounting strength	No damage when 49 N pull load was applied for 10 s in all directions.				
Degree of protection	IEC60529 IP50				
Weight	Approx. 30 g				

- Note:**
1. Perform positioning teaching within the stable sensing distance, otherwise reset failures may result when the E2C-T is in operation. If a fine-difference teaching is performed with and without a sensing object, reset failures may result when the E2C-T is in operation even if teaching is successful.
  2. The above distances for teaching without sensing object were measured without surrounding metal or background.

**Terminal Block Units**

Model	E39-JID01
Input current	10 mA max.
ON voltage	12 VDC min. between input terminal and external sensor power supply
OFF voltage	4 VDC max. between input terminal and external sensor power supply
OFF current	1 mA max.
ON delay time	1 ms max. (connected to SRT1-□□D04S)
OFF delay time	1.5 ms max. (connected to SRT1-□□D04S)
Input indicators	LED (Orange)
External sensor current capacity	50 mA max.
Vibration resistance	10 to 55 Hz, 1.5-mm double amplitude
Shock resistance	Malfunction: 200 m/s <sup>2</sup> Destruction: 300 m/s <sup>2</sup>
Mounting method	M4 screws or 35-mm DIN track mounting
Mounting strength	No damage when 50 N pull load was applied for 10 s in all directions (except the DIN track directions and a pulling force of 10 N)
Terminal strength	No damage when 49 N pull load was applied for 10 s in all directions. Tighten each screw to a torque of 0.6 to 1.18 N • m.
Ambient temperature	Operating: 0°C to 55°C (with no icing or condensation) Storage: -20°C to 65°C (with no icing or condensation)
Ambient humidity	Operating: 35% to 85%
Weight	25 g max.

# Nomenclature

SRT1-TID04S  
SRT1-TKD04S

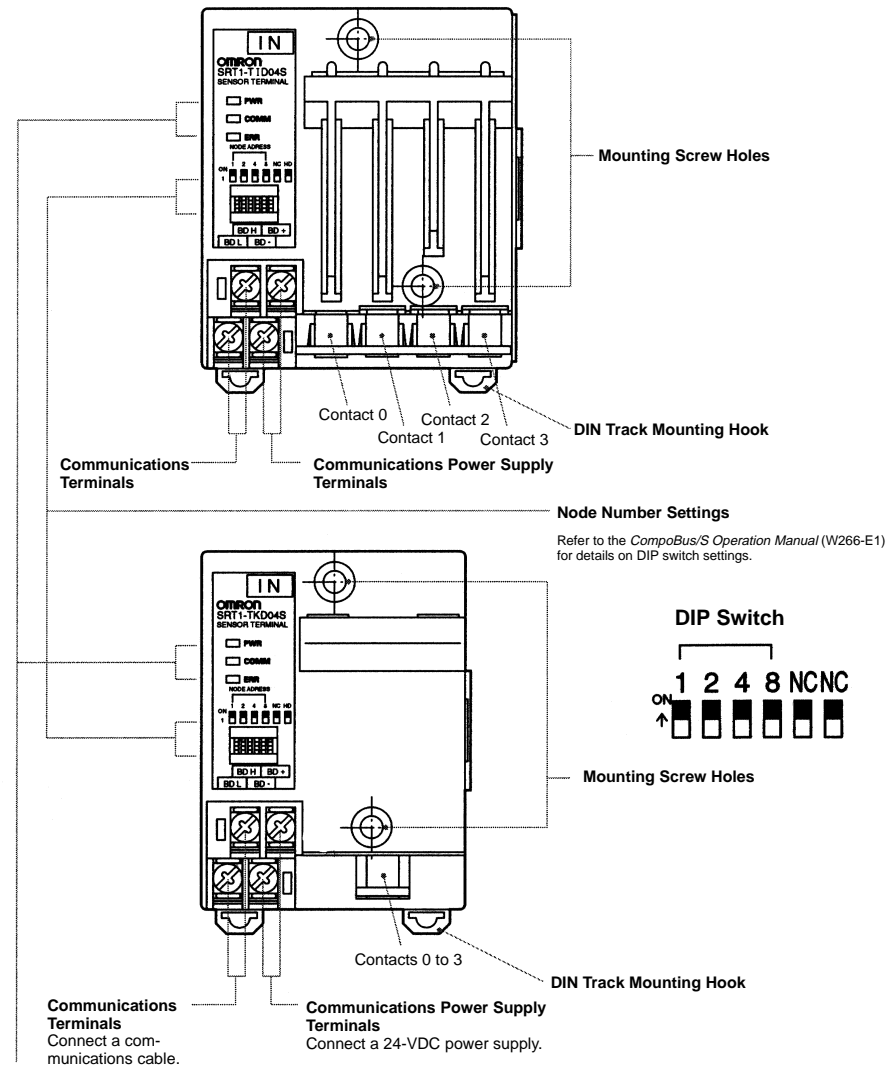

## Indicators

Indicator	Name	Display	Color	Meaning
PWR	Power supply	Lit	Green	The communications power supply is ON.
		Not lit		The communications power supply is OFF.
COMM	Communications	Lit	Yellow	Normal communications.
		Not lit		A communications error has occurred or the Unit is in standby status.
ERR	Communications error	Lit	Red	A communications error has occurred.
		Not lit		Normal communications or the Unit is in standby status.



# Dimensions

Note: All units are in millimeters unless otherwise indicated.

SRT1-TID04S

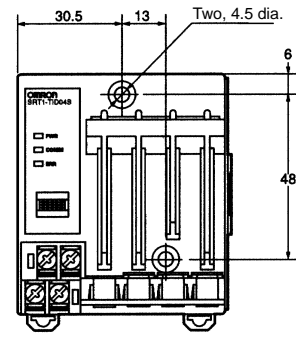
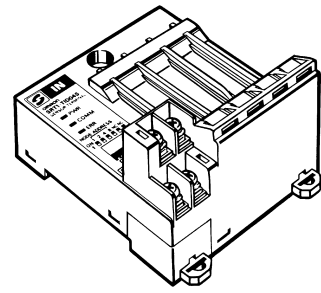

Mounting Holes

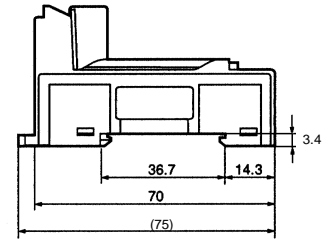
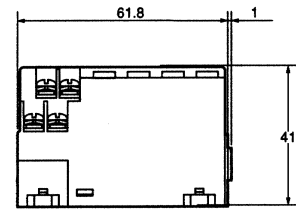
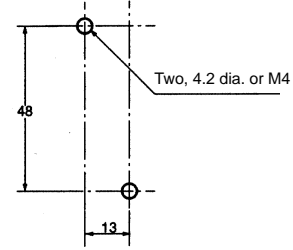

SRT1-XID04S

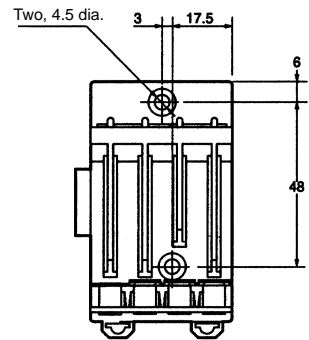
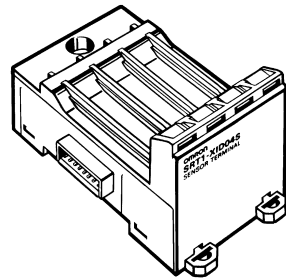

Mounting Holes

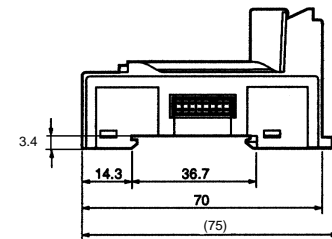
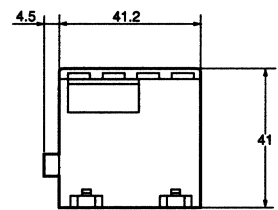
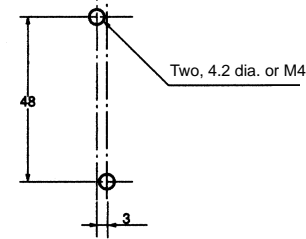

SRT1-TKD04S

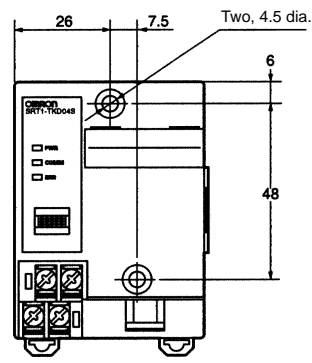
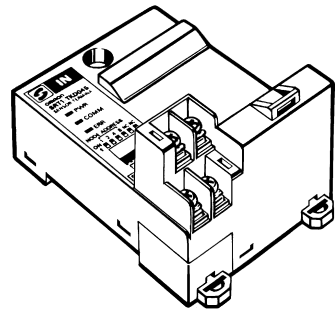

Mounting Holes

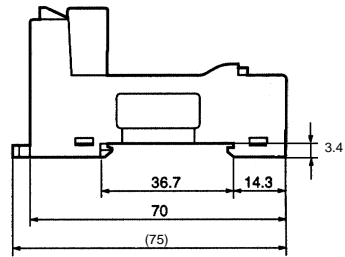
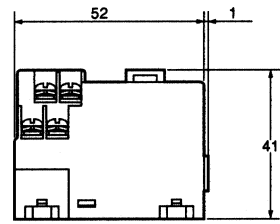
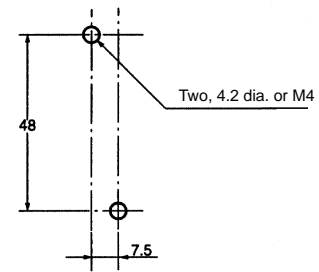

SRT1-XKD04S

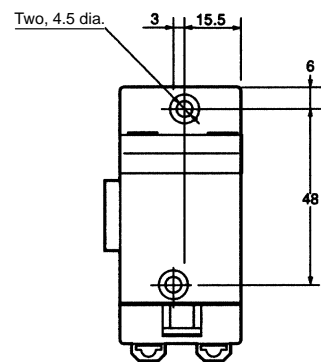
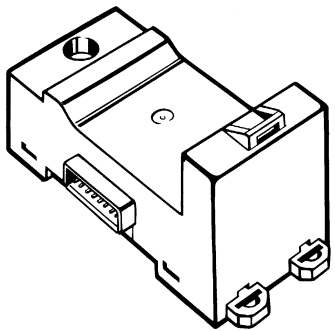

Mounting Holes

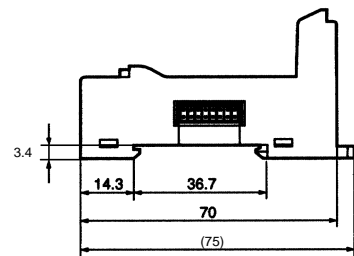
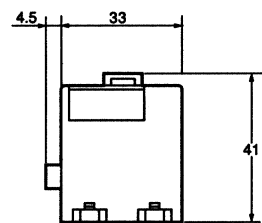
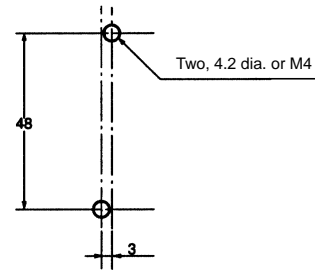

E3X-NM16

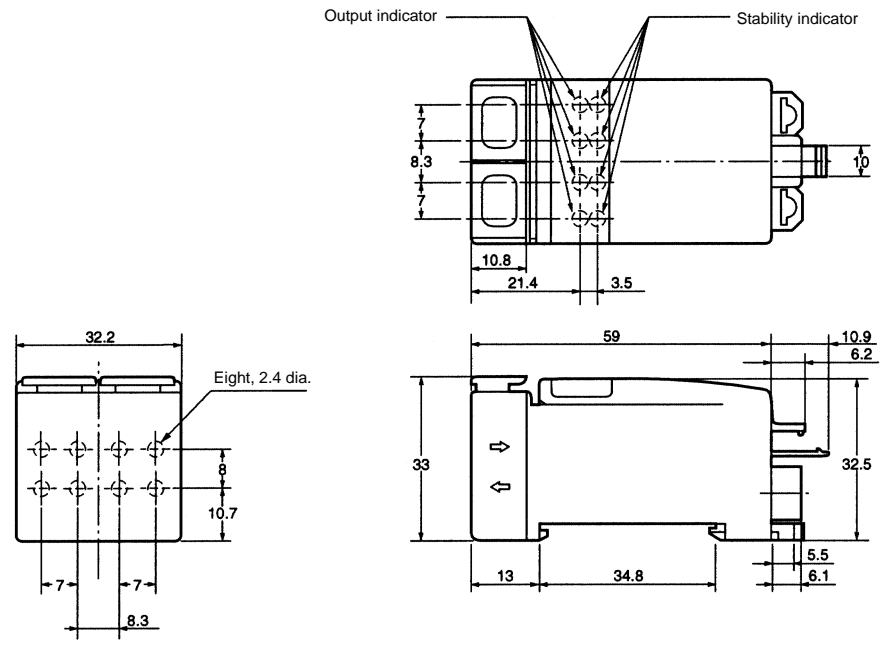
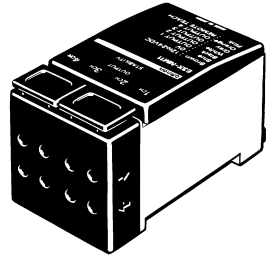

E3X-NT□6

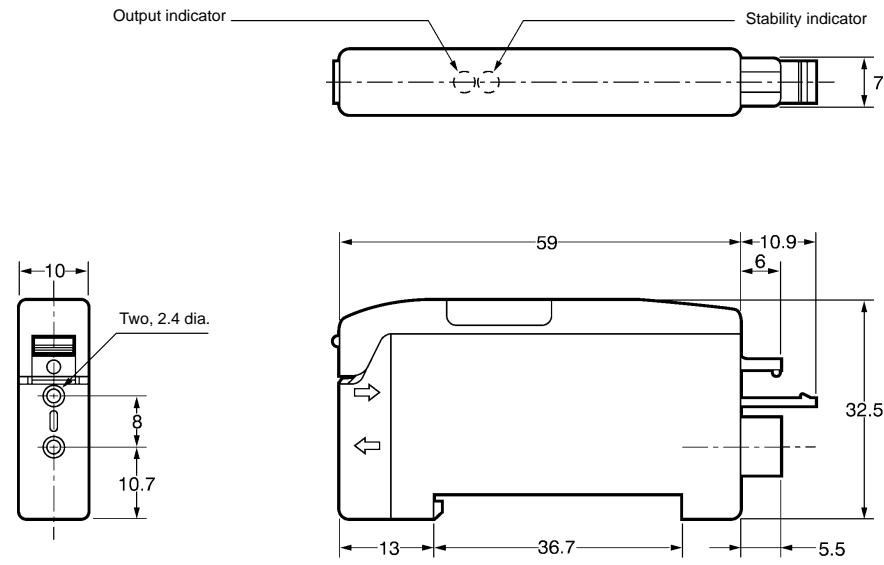
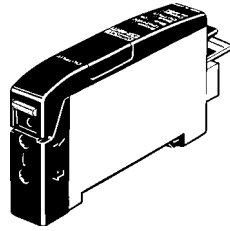

E3X-NH16

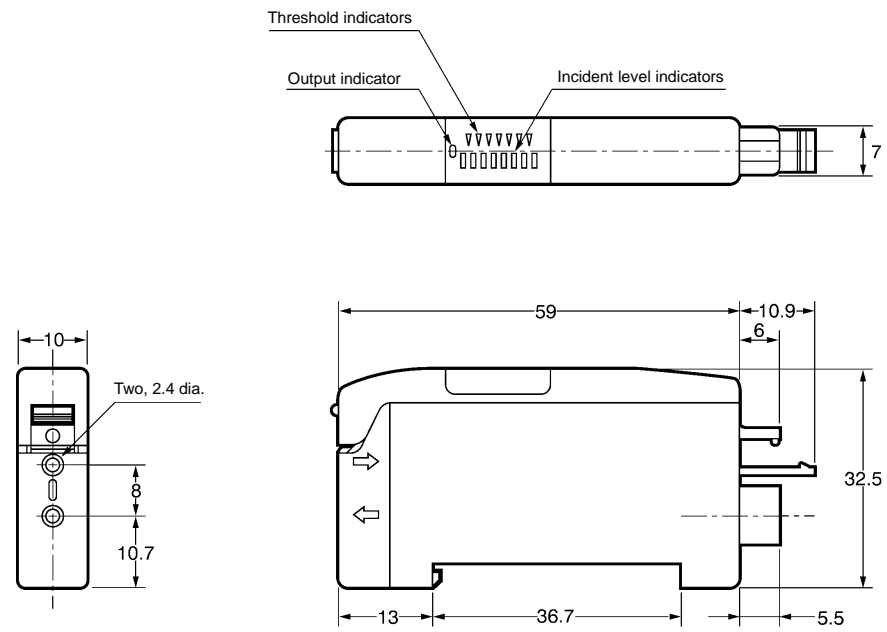
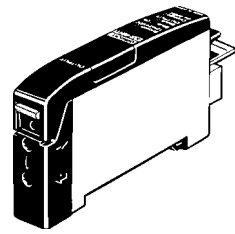

E3X-DA16

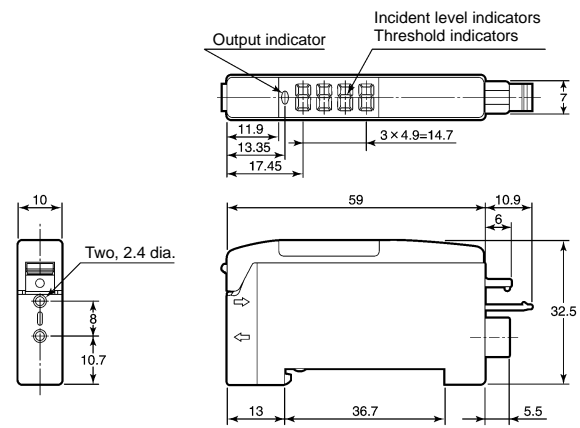
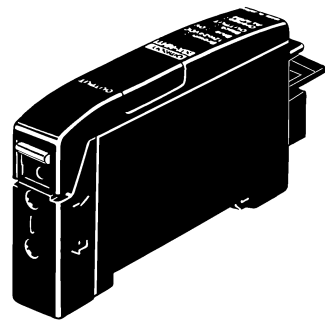

E39-JID01

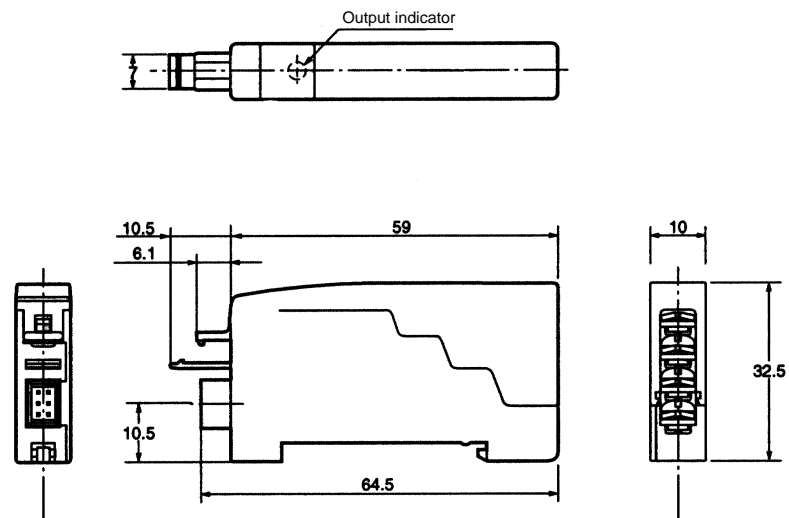
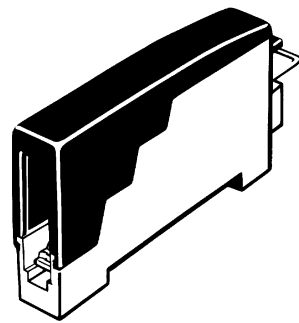

E2CY-T16

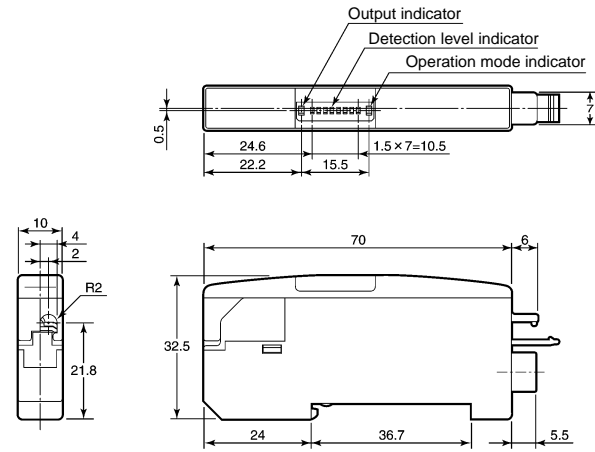
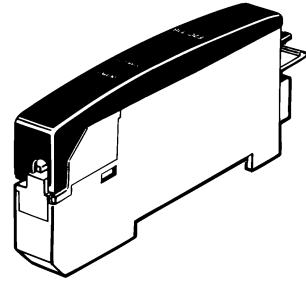

E2C-T16

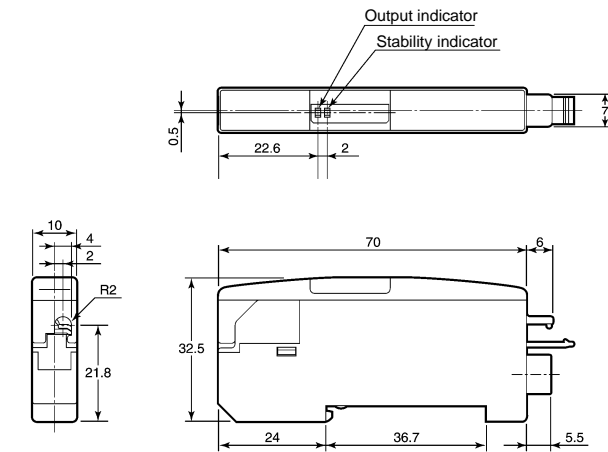
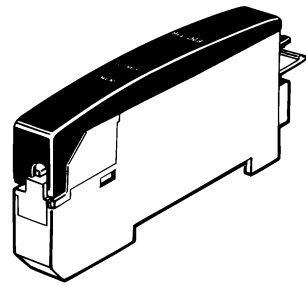

# Installation

## Internal Circuit Configuration

E39-JID01

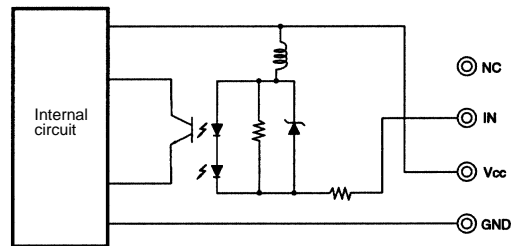

# Precautions

Refer to the *CompoBus/S Operation Manual (W266-E1)* before using the Terminal.

## General-purpose Sensors and the Equivalent CompoBus/S Sensors

CompoBus/S product	General-purpose product	Difference
E3X-NT16	E3X-NT11	External appearance only
E3X-NT26	E3X-NT21	
E3X-NM16	E3X-NM11	
E3X-NH16	E3X-NH11	
E3X-DA16	E3X-DA11	
E2CY-T16	E2CY-T11	
E2C-T16	E2C-T11	

## General Safety Precautions

### Connection Units

Use only the Connection Units listed in this data sheet for the Sensor Amplifier Units.

### E39-JID01 Terminal Block Unit

Do not apply any voltage to the Terminal Block Unit.

### Correct Use

#### Expanding Sensor Amplifier Terminals

1. Remove the cover from the side of the SRT1-T□D04S. (See Figure 1.)
2. When the cover is removed, you can see the expansion connector inside.
3. Connect this expansion connector to the connector located on the side of the SRT1-X□D04S. (See Figure 2.)

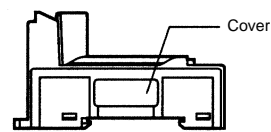

Figure 1

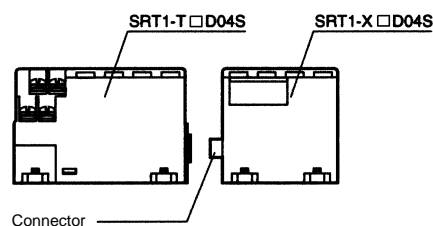

Figure 2

## Attaching and Removing Connection Units

Sensor Amplifier Terminal	Connection Unit
SRT1-TID04S	E3X-DA16 E3X-NT□6 E39-JID01
SRT1-XID04S	E3X-NH□6 E2CY-T16 E2C-T16

(SRT1-TID04S, SRT1-XID04S, E3X-NT□6, E39-JID01)

### Attaching Connection Units

1. Hook Section A of the Connection Unit onto Section B of the Sensor Amplifier Terminal.
2. Push in the Connection Unit until Section C locks inside Section D of the Sensor Amplifier Terminal.

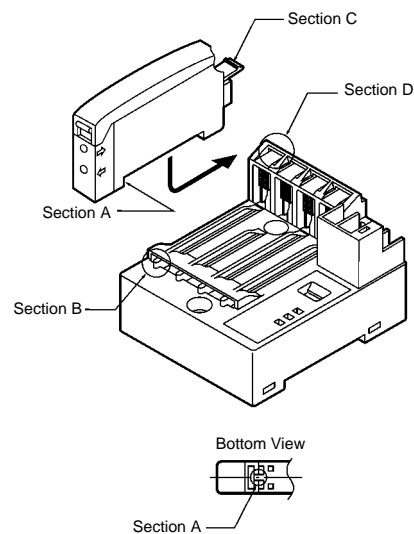

### Removing Connection Units

1. While pushing Section D, pull the Connection Unit in direction E.
2. When Section D releases from the lock, the Connection Unit can be removed.

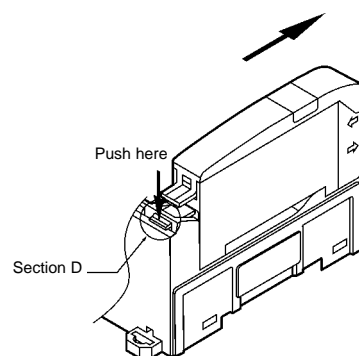

**Attaching or Removing Connection Unit**

Sensor Amplifier Terminal	Connection Unit
SRT1-TKD04S SRT1-XKD04S	E3X-NM16

**Attaching Connection Unit**

1. Hook Section A of the Connection Unit onto Section B of the Sensor Amplifier Terminal.
2. Push in the Connection Unit until Section C locks inside Section D of the Sensor Amplifier Terminal.

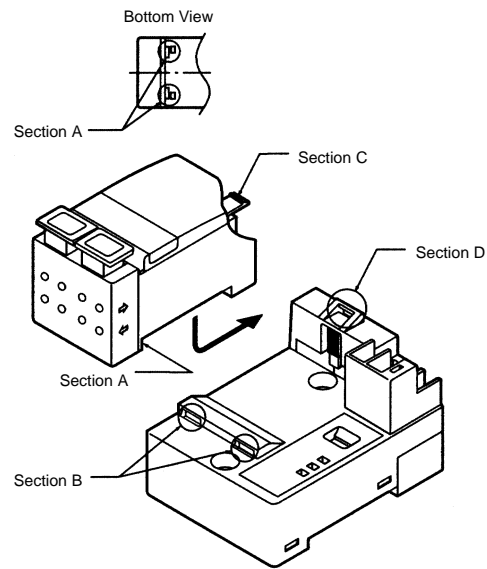

**Removing Connection Unit**

1. While pushing Section D, pull the Connection Unit in direction E.
2. When Section D releases from the lock, the Connection Unit can be removed.

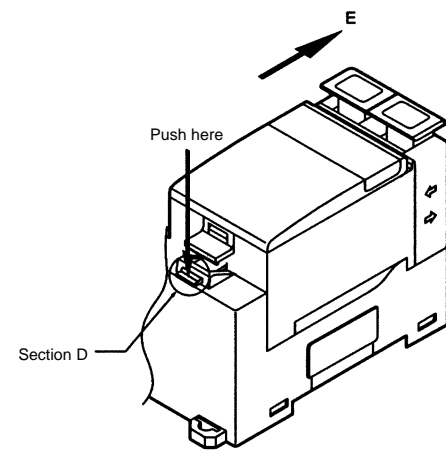

**Channel Numbers**

Channel numbers 1 to 4 of the E3X-NM16 correspond to contact numbers 0 to 3 of the SRT1-TKD04S, and to contact numbers 4 to 7 of the SRT1-XKD04S.

## Analog Input Terminal

SRT2-AD04

**Compact Analog Input Model is the Same Shape as 16-point Remote I/O Terminals**

- Allows flexible input point settings up to a maximum of four points.
- Resolution: 1/6,000
- Takes only 1 ms to exchange each input point.
- Wide input ranges available.
- 105 x 48 x 50 (W x H x D)

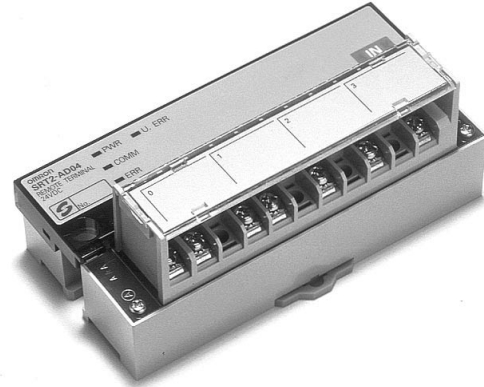

## Ordering Information

Classification	I/O points	Model
Analog Input Terminal	1 to 4 (selectable with DIP switch)	SRT2-AD04

**Note:** For details about connecting the SRT2-AD04 to the Master Unit. Refer to page 25.

## Specifications

### ■ Ratings

#### Input

Item	Voltage input	Current input
Max. signal input	±15 V	±30 mA
Input impedance	1 MΩ max.	Approx. 250 Ω
Resolution	1/6,000 (FS)	
Total accuracy	25°C	±0.3% FS
	-10 to 55°C	±0.6% FS
Conversion time	4 ms/4 points, 3 ms/3 points, 2 ms/2 points, and 1 ms/1 point	
Dielectric strength	500 VAC for 1 min between communications power supply, analog input, and communications terminals (see note)	

**Note:** There is no insulation between analog inputs.

### ■ Characteristics

Communications power supply voltage	14 to 26.4 VDC (possible to provide through Special Flat Cable)
Current consumption	100 mA max.
Connection method	Multi-drop method and T-branch method
Dielectric strength	500 VAC (between insulated circuits)
Noise immunity	Conforms to IEC61000-4-4, 2 kV (power lines)
Vibration resistance	10 to 150 Hz, 1.0-mm double amplitude or 70 m/s <sup>2</sup>
Shock resistance	200 m/s <sup>2</sup>
Mounting strength	No damage with 100 N pull load applied in all directions.
Terminal strength	No damage with 100 N pull load applied
Screw tightening torque	0.3 to 0.5 N • m
Ambient temperature	Operating: -10°C to 55°C Storage: -25°C to 65°C
Ambient humidity	Operating: 25% to 85% (with no condensation)
Weight	Approx. 120 g



# Nomenclature

SRT2-AD04

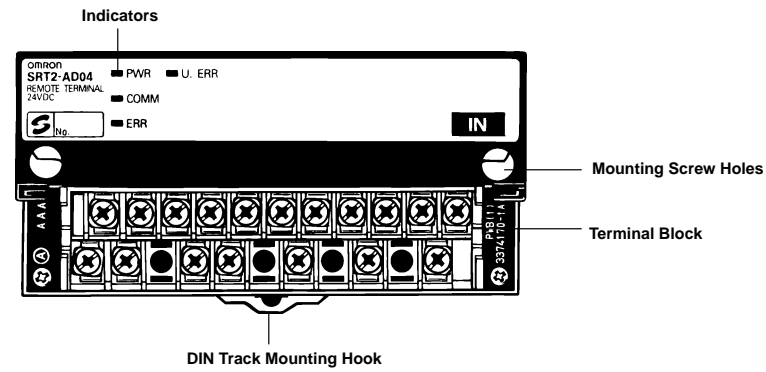

## Indicators

Indicator	Name	Color	Display	Meaning
PWR	Power supply	Green	Lit	The communications power supply is ON.
			Not lit	The communications power supply is OFF.
COMM	Communication	Yellow	Lit	Normal communications
			Not lit	A communications error has occurred or the Unit is in standby status.
ERR	Communication error	Red	Lit	A communications error has occurred.
			Not lit	Normal communications or the Unit is in standby status.
U.ERR	Unit error	Red	Lit	An error has occurred in the Unit.
			Not lit	Normal communications or the Unit is in standby status.

## DIP Switch (SW101)

(Open cover to access.)

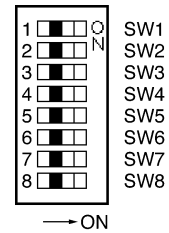

Pin 1	Pin 2	Input points
OFF	OFF	4 points (default setting)
OFF	ON	3 points (inputs 0 to 2 enabled)
ON	OFF	2 points (inputs 0 and 2 enabled)
ON	ON	1 point (input 0 enabled)

Pin 3	Communications mode
OFF	High-speed communications (default setting)
ON	Long-distance communications

Pin 4	Be sure to turn OFF.
-------	----------------------

Pin No.	Node address
Pin 5	2 <sup>3</sup>
Pin 6	2 <sup>2</sup>
Pin 7	2 <sup>1</sup>
Pin 8	2 <sup>0</sup>

The default setting is for all of these pins to be OFF.

## DIP Switch (SW102)

(Open cover to access.)

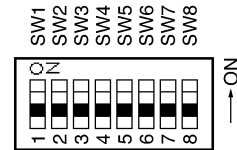

Pin 1	Pin 2	Pin 3	Range for inputs 0, 1
Pin 4	Pin 5	Pin 6	Range for inputs 2, 3
OFF	OFF	OFF	0 to 5 (V) (default setting)
ON	OFF	OFF	1 to 5 (V)
OFF	ON	OFF	0 to 10 (V)
ON	ON	OFF	-10 to 10 (V)
OFF	OFF	ON	4 to 20 (mA)
ON	OFF	ON	0 to 20 (mA)

Do not make any settings other than the ones listed above.

Pin 7	Mean value processing
OFF	Without mean value processing (default setting)
ON	With mean value processing (mean for 8 operations)

Pin 8	Be sure to turn OFF.
-------	----------------------

# Dimensions

Note: All units are in millimeters unless otherwise indicated.

## SRT2-AD04

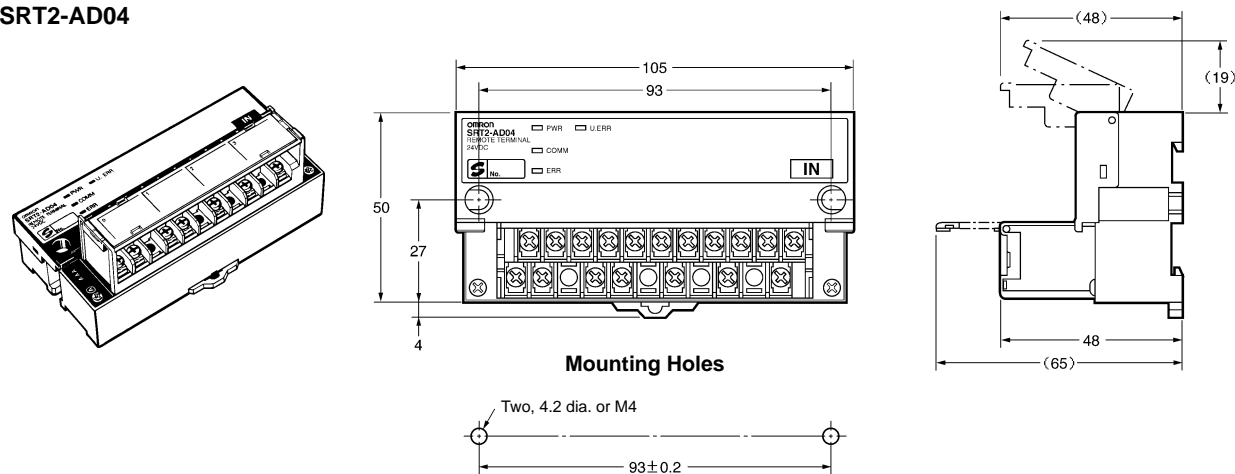

# Installation

## Internal Circuit Configuration

### SRT2-AD04

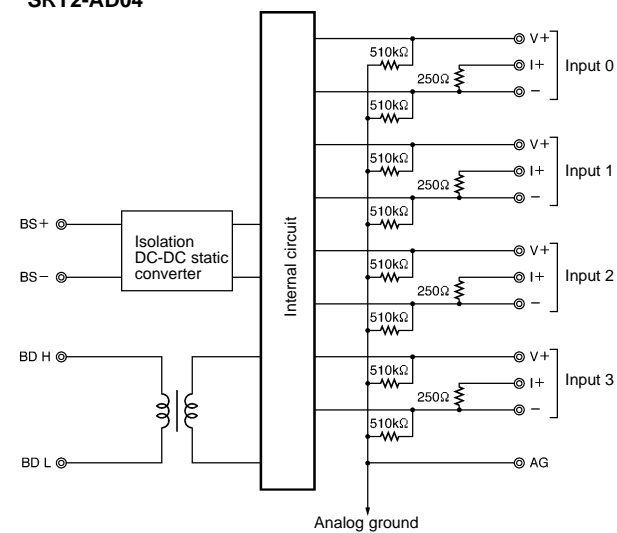

## Terminal Arrangement

### SRT2-AD04

BD	BS	AG	V0	I0	V1	I1	V2	I2	V3	I3
H	+		+	+	+	+	+	+	+	+
BD	BS	NC	AG	0-	NC	1-	NC	2-	NC	3-
L	-									

Note: When the input is current input, short-circuit the "V+" terminals and the "I-" terminals. When short-circuiting, use the short-circuiting tool provided as an accessory.

# Precautions

Refer to the *CompoBus/S Operation Manual (W266-E1)* before using the Unit.

## Analog Output Terminal

SRT2-DA02

Compact Analog Output Model is the Same Shape as 16-point Remote I/O Terminals

- Two output points or 1 output point is selectable.
- Resolution: 1/6,000
- 105 x 48 x 50 (W x H x D)

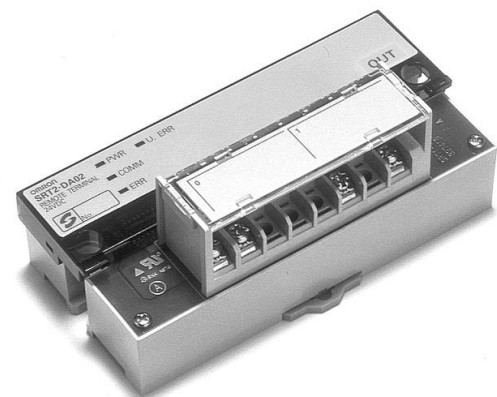

## Ordering Information

Classification	I/O points	Model
Analog Output Terminal	1 or 2 (selectable with DIP switch)	SRT2-DA02

**Note:** For details about connecting the SRT2-DA02 to the Master Unit, refer to page 25.

## Specifications

### ■ Ratings

#### Output

Item	Voltage output	Current output
External output permissible load resistance	5 k $\Omega$ min.	600 $\Omega$ max.
Output impedance	0.5 $\Omega$ max.	---
Resolution	1/6,000 (FS)	
Total accuracy	25°C	$\pm 0.4\%$ FS
	-10 to 55°C	$\pm 0.8\%$ FS
Conversion time	2 ms/2 points and 2 ms/1 point	
Dielectric strength	500 VAC for 1 min between communications power supply, analog output, and communications terminals (see note)	

**Note:** There is no insulation between analog outputs.

### ■ Characteristics

Communications power supply voltage	14 to 26.4 VDC (power supply possible from Special Flat Cable)
Current consumption (see note)	170 mA max.
Connection method	Multi-drop method and T-branch method
Dielectric strength	500 VAC (between insulated circuits)
Noise immunity	Conforms to IEC61000-4-4, 2 kV (power lines)
Vibration resistance	10 to 150 Hz, 1.0-mm double amplitude or 70 m/s <sup>2</sup>
Shock resistance	200 m/s <sup>2</sup>
Mounting strength	No damage when 100 N pull load was applied in all directions
Terminal strength	No damage when 100 N pull load was applied
Screw tightening torque	0.3 to 0.5 N · m
Ambient temperature	Operating: -10°C to 55°C Storage: -25°C to 65°C
Ambient humidity	Operating: 25% to 85% (with no condensation)
Weight	Approx. 100 g

**Note:** The above current consumption is the value with all points turned ON excluding the current consumption of the external load.

# Nomenclature

SRT2-DA02

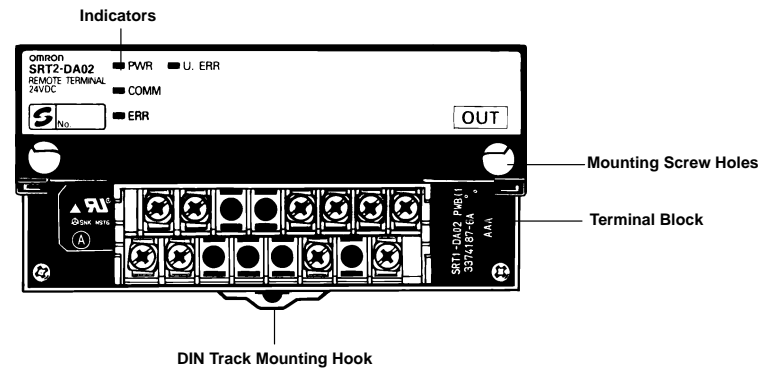

## Indicators

Indicator	Name	Color	Display	Meaning
PWR	Power supply	Green	Lit	The communications power supply is ON.
			Not lit	The communications power supply is OFF.
COMM	Communication	Yellow	Lit	Normal communications
			Not lit	A communications error has occurred or the Unit is in standby status.
ERR	Communication error	Red	Lit	A communications error has occurred.
			Not lit	Normal communications or the Unit is in standby status.
U.ERR	Unit error	Red	Lit	An error has occurred in the Unit.
			Not lit	A communications error has occurred or the Unit is in standby status.

## DIP Switch (SW101)

(Open cover to access.)

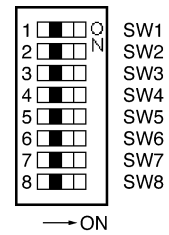

<b>Pin 1</b>	Be sure to turn OFF.
--------------	----------------------

<b>Pin 2</b>	<b>Output points</b>
OFF	2 points (default setting)
ON	1 point (output 0 enabled)

<b>Pin 3</b>	<b>Communications mode</b>
OFF	High-speed communications (default setting)
ON	Long-distance communications

<b>Pin 4</b>	Be sure to turn OFF.
--------------	----------------------

<b>Pin No.</b>	<b>Node addresses</b>
<b>Pin 5</b>	2 <sup>3</sup>
<b>Pin 6</b>	2 <sup>2</sup>
<b>Pin 7</b>	2 <sup>1</sup>
<b>Pin 8</b>	2 <sup>0</sup>

The default setting is for all of these switches to be OFF.

## DIP Switch (SW102)

(Open cover to access.)

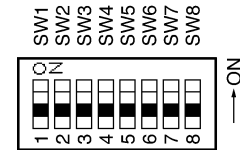

Pin 1	Pin 2	Pin 3	Range for output 0
Pin 4	Pin 5	Pin 6	Range for output 1
OFF	OFF	OFF	0 to 5 (V) (default setting)
ON	OFF	OFF	1 to 5 (V)
OFF	ON	OFF	0 to 10 (V)
ON	ON	OFF	-10 to 10 (V)
OFF	OFF	ON	4 to 20 (mA)

Do not make any settings other than the ones listed above.

Pin 7	Pin 8	Output during communications error
OFF	OFF	Clear at the output lower limit when communications error occurs. (default setting)
OFF	ON	Clear at the output upper limit when communications error occurs.
ON	OFF	Clear at the output lower limit when communications error occurs (however, if the range is -10 to 10 V, the output will be 0).
ON	ON	Output held when communications error occurs.

## Dimensions

Note: All units are in millimeters unless otherwise indicated.

### SRT2-DA02

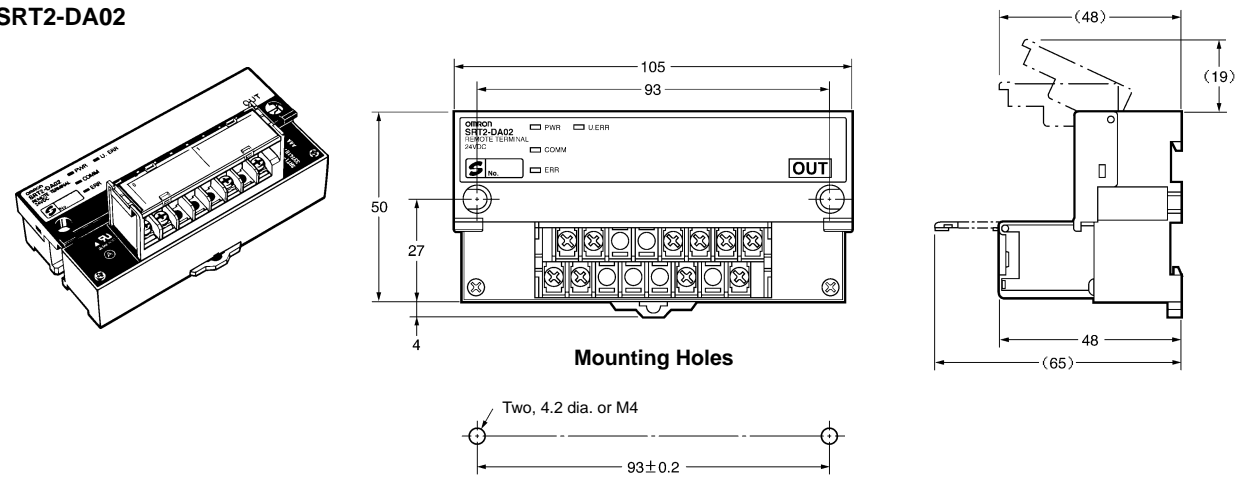

## Installation

### Internal Circuit Configuration

#### SRT2-DA02

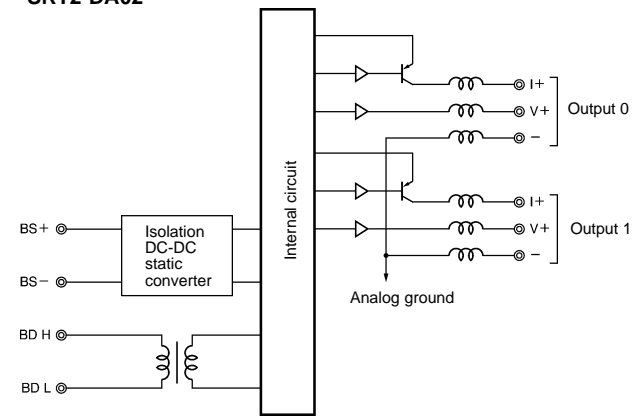

### Terminal Arrangement

#### SRT2-DA02

H	BS +	NC	NC	V0 +	I0 +	V1 +	I1 +
BD L	BS -	NC	NC	NC	0-	NC	1-

## Precautions

Refer to the *CompoBus/S Operation Manual (W266-E1)* before using the Unit.

## Remote I/O Modules

SRT2-ID16P/OD16P

### Module Type that Allows PCB Mounting

- Compact size at 60 x 16 x 35 (W x H x D)
- Lineup now includes the 16-point input model and 16-point output model.

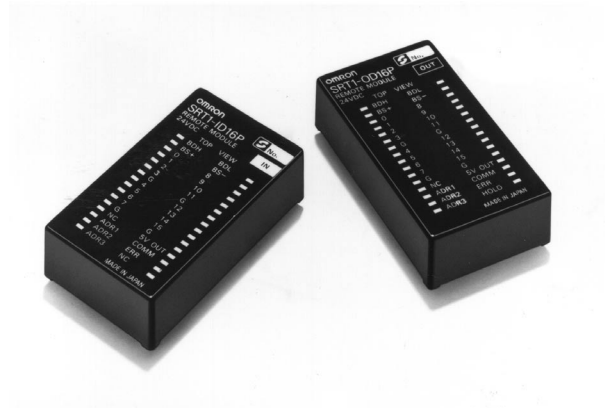

### Ordering Information

I/O classification	Internal I/O circuit common	I/O points	Rated voltage	I/O rated voltage	Model
Input	NPN (+ common)	16	24 VDC	24 VDC	SRT2-ID16P
Output	NPN (- common)				SRT2-OD16P

### Specifications

#### ■ Ratings

##### Input (SRT2-ID16P)

Input current	2 mA max./point
ON delay time	1.5 ms max.
OFF delay time	1.5 ms max.
ON voltage	15 VDC min. between each input terminal and BS+ terminal
OFF voltage	5 VDC max. between each input terminal and BS + terminal

##### Output (SRT2-OD16P)

Rated output current	0.2 A/point, 0.6 A/common
Residual voltage	0.6 V max. between each output terminal and G terminal at 0.2 A
Leakage current	0.1 mA max. between each output terminal and G terminal at 24 VDC

#### ■ Characteristics

Communications power supply voltage	20.4 to 26.4 VDC
I/O power supply voltage	24 VDC +10%/-15%
Current consumption (see note)	60 mA max.
Connection method	Multi-drop method and T-branch method
Connecting Units	8 Input Terminals and 8 Output Terminals per Master
Dielectric strength	500 VAC for 1 min (1-mA sensing current between insulated circuits)
5-V output current	20 mA max. (5 V ± 0.5 V)
LED drive current (COMM, ERR)	10 mA max. (5 VDC)
SW carry current (ADRO to 3, HOLD)	1 mA max.
Ambient temperature	Operating: 0°C to 55°C (with no icing or condensation) Storage: -20°C to 65°C (with no icing or condensation)
Ambient humidity	Operating: 35% to 85%
Weight	35 g max.

**Note:** The above current consumption is the value with all points turned ON excluding the current consumption of the external sensor connected to the input model and the current consumption of the load connected to the output model.

# Dimensions

Note: All units are in millimeters unless otherwise indicated.

SRT2-ID16P  
SRT2-OD16P

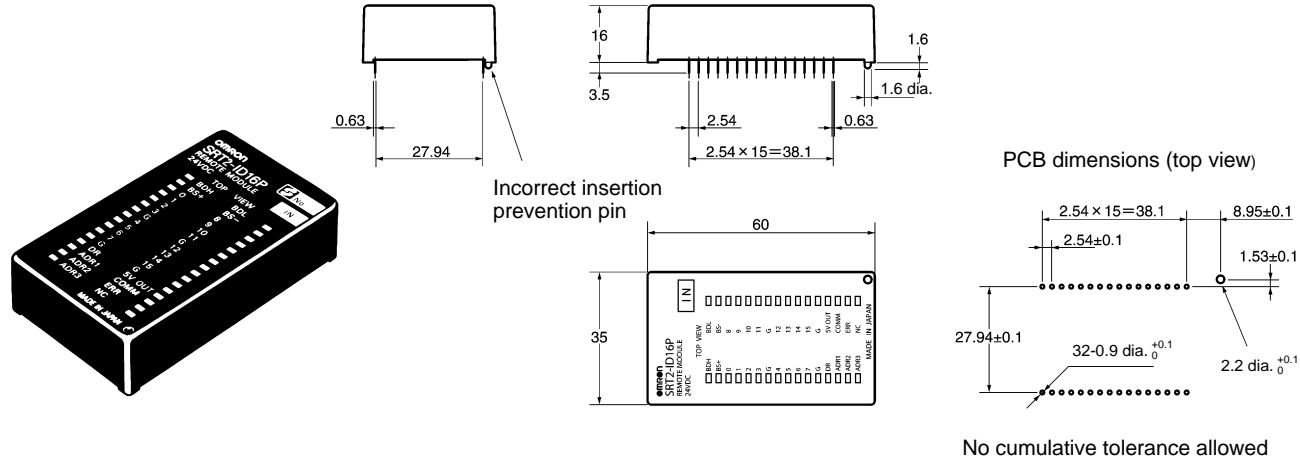

# Installation

## Internal Circuit Configuration

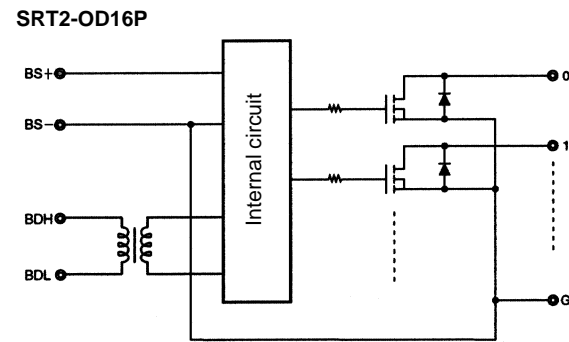
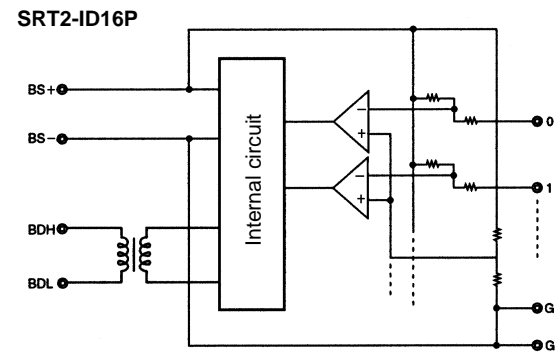

## External Connections

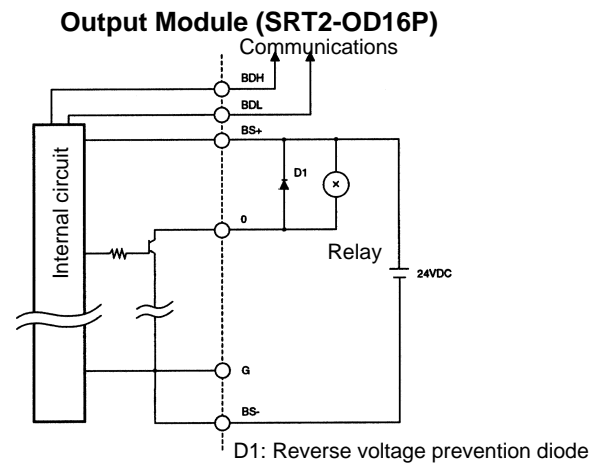
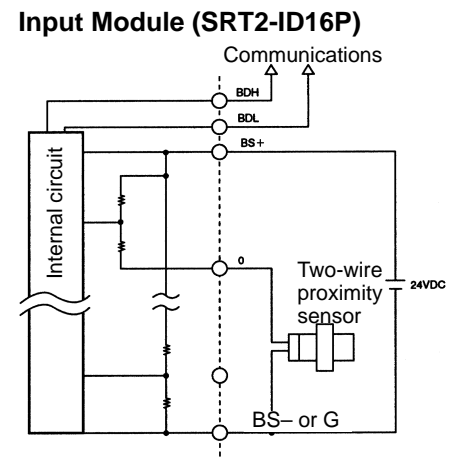

### Node Number Settings and Output HOLD/CLEAR Mode

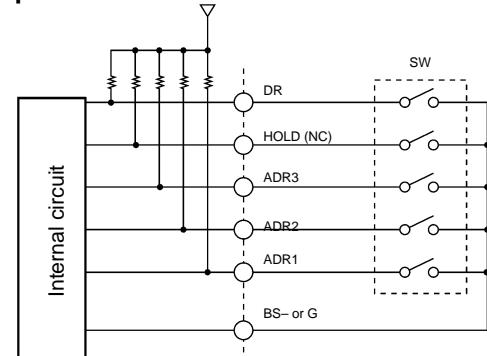

Note: NC in parentheses is for the Input Modules.

**Note:** Refer to the *CompoBus/S Operation Manual (W266-E1)* for details on the switch.

### Indicators

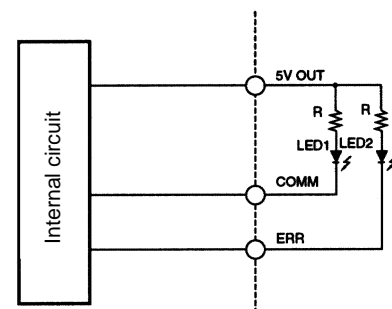

R: LED current limiting resistor  
LED1: LED for COMM  
LED2: LED for ERR  
The maximum current for LED1 and 2 is 10 mA.

The 5-V Output Terminals have positive power supplies (maximum output current of 20 mA) for the ERR and COMM LEDs. Recommended LED colors are red for ERR and yellow for COMM.

## Precautions

Refer to the *CompoBus/S Operation Manual (W266-E1)* before using the Unit.

### Correct Use

#### Noise Protection Circuit

Add the following protection circuit if noise is generated from the power supply, input section, or output section.

#### Power Supply Noise Protection Circuit

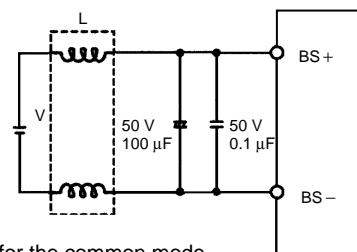

L: Coil for the common mode  
Install the coil near the SRT1.  
V: 24-VDC power supply

#### Input Section Noise Protection Circuit

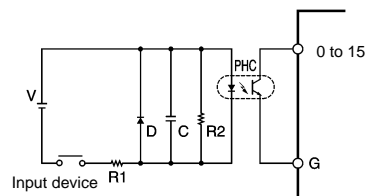

R<sub>1</sub>: Resistor for limiting photocoupler's input current  
D: Diode for protecting the photocoupler  
C: Condenser for absorbing noise  
R<sub>2</sub>: Resistor for limiting the operating level  
PHC: Photocoupler  
V: DC power supply

#### Output Section Noise Protection Circuit

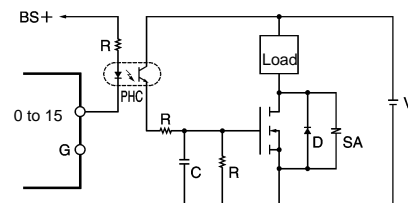

C: Capacitance of 0.1 µF min.  
R: Limiting resistor  
SA: Varistor  
D: Diode for protecting against counterelectromotive force  
PHC: Photocoupler  
V: DC power supply

#### 5-V Output Terminals

The 5-V Output Terminals have positive power supplies (maximum output current of 20 mA) for the ERR and COMM LED. Use them as shown below. Recommended LED colors are red for ERR and yellow for COMM.

#### Wiring Method

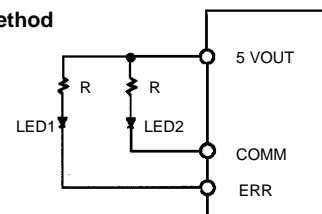

R: LED current limiting resistor  
LED1: LED for COMM  
LED2: LED for ERR  
The maximum current for the LED1 and 2 is 10 mA.

#### Cleaning the PCB

- Perform soldering using a soldering iron at a temperature between 280 and 300°C in less than 3 seconds, or at a temperature less than 280°C in less than 5 seconds.
- Do not clean the PCB flux either using highly acidic or alkaline detergents, or using ultrasonic cleaning.

#### NC Terminals

NC terminals are used internally. Do not make any connections to the NC terminals.



#### Advanced Servodrivers with Positioner Functions

#### DIO and CompoBus/S Models are Newly Added

- Servodriver and positioner are combined into one Unit.
- Conventional U-series, U-series UE type, H-series, and M-series AC Servomotors can be used.
- Feeder control/DTP control and single operation/automatic incremental/continuous operation are available.
- Easy to set, operate, and adjust.



#### Ordering Information

Specifications		Model	
CompoBus/S models	For 200-VAC input	6 A	FND-X06H-SRT
		12 A	FND-X12H-SRT
		25 A	FND-X25H-SRT
		50 A	FND-X50H-SRT
	For 100-VAC input	6 A	FND-X06L-SRT
		12 A	FND-X12L-SRT

**Note:** For details, refer to *OMNUC FND-X-series User's Manual (I524)*.

#### Specifications

##### ■ General Specifications

<b>Ambient temperature</b>	Operating: 0°C to 55°C Storage: -10°C to 70°C
<b>Ambient humidity</b>	Operating: 35% to 90% (with no icing) Storage: 35% to 90% (with no icing)
<b>Operating atmosphere</b>	No corrosive gases
<b>Dielectric strength</b>	1,500 VAC <sub>RMS</sub> for 1 min at 50/60 Hz
<b>Insulation resistance</b>	5 MΩ min. (at 500 VDC) between power input terminals and between the power terminal and the case
<b>Vibration resistance</b>	10 to 150 Hz in X, Y, and Z directions with 0.10-mm single amplitude; acceleration: 9.8 m/s <sup>2</sup> max.; time coefficient: 8 min; 4 sweeps
<b>Shock resistance</b>	98 m/s <sup>2</sup> max., three times each in X, Y, and Z directions
<b>Degree of protection</b>	Built into panel (IP00)

■ Performance Specifications

DIO models (see note 1)		FND-X06L	FND-X12L	FND-X06H	FND-X12H	FND-X25H	FND-X50H
CompoBus/S models (see note 1)		FND-X06L-SRT	FND-X12L-SRT	FND-X06H-SRT	FND-X12H-SRT	FND-X25H-SRT	FND-X50H-SRT
Item							
Continuous output current (0-P)		2.0 A	3.0 A	2.0 A	4.8 A	8.0 A	20 A
Momentary maximum output current (0-P)		6.0 A	12 A	6.0 A	12 A	25 A	50 A
Input power supply	Main circuit	Single-phase 100/115 VAC (85 to 127 V) 50/60 Hz (The same terminals are used for the main circuit and the control circuit.)			Single-phase 200/240 VAC (170 to 264 V) 50/60 Hz (The same terminals are used for the main circuit and the control circuit.)		3-phase 200/240 VAC (170 to 264 V) 50/60 Hz
	Control circuit						Single-phase 200/240 VAC (170 to 264 V) 50/60 Hz
Position/speed feedback	U Series (INC)	30 to 750 W: Optical incremental encoder, 2,048 pulses/revolution 1 to 2 kW: Optical incremental encoder, 4,096 pulses/revolution					
	U Series (ABS)	30 to 750 W: Optical absolute encoder, 1,024 pulses/revolution 1 to 2 kW: Optical absolute encoder, 8,192 pulses/revolution					
	U-UE Series	Optical incremental encoder, 1,024 pulses/revolution					
	H Series	Magnetic incremental encoder, 2,000 pulses/revolution					
	M Series	Resolver, absolute accuracy 0.18° max.; ambient temperature 25°C					
Applicable load inertia	U Series (INC)	Maximum of 30 times motor's rotor inertia		Maximum of 30 times motor's rotor inertia		Maximum of 20 times motor's rotor inertia (10 times for 1-kW motor)	Maximum of 10 times motor's rotor inertia
	U Series (ABS)	Maximum of 20 times motor's rotor inertia		Maximum of 20 times motor's rotor inertia		Maximum of 18 times motor's rotor inertia (10 times for 1-kW motor)	Maximum of 10 times motor's rotor inertia
	U-UE Series	Maximum of 30 times motor's rotor inertia		Maximum of 30 times motor's rotor inertia		Maximum of 20 times motor's rotor inertia	---
	H Series	Maximum of 10 times motor's rotor inertia					
	M Series	Maximum of 10 times motor's rotor inertia					
Inverter method		PWM method based on IGBT					
PWM frequency		10 kHz					
Weight		Approx. 1.5 kg		Approx. 1.5 kg		Approx. 2.5 kg	Approx. 4.5 kg
Frequency response (speed control)		100 Hz (at a load inertia equivalent to motor's rotor inertia)					
Position loop gain		1 to 200 (rad/s)					
Feed forward		0% to 200% of speed reference					
Pulse rate		$1/32,767 \leq (\text{pulse rate 1} / \text{pulse rate 2}) \leq 32,767/1$					
Positioning completion width		1 to 32,767 (pulses)					
Acceleration/Deceleration time		0 to 9,999 (ms); acceleration and deceleration times set separately. Two types can be set for each. S-curve acceleration/deceleration function available (filter time constant: 0.00 to 32.76 s).					
Sequence input		19 pts. (limit inputs, origin proximity, RUN command, START, alarm reset, origin search, JOG operation, teaching, point selection, position data, deceleration stop) Photocoupler input: 24 VDC, 8 mA External power supply: 24 VDC ±1 V, 150 mA min.					
Sequence output		15 pts. (brake output, READY, origin search completion, origin, teaching, motor running, positioning completion, alarm, point output, position selection, speed selection) Open collector output: 24 VDC, 40 mA					
Monitor output (See note 2.)	Speed monitor	3 V/motor's rated speed (output accuracy: approx. ±10%)					
	Current monitor	3 V/motor's maximum current (output accuracy: approx. ±10%)					
Regenerative absorption capacity		13 W + 17 J	17 W + 17 J	13 W + 17 J	24 W + 17 J	37 W + 22 J	160 W + 38 J
Protective functions		Overcurrent, overvoltage, voltage drop, resolver disconnection, power status error, clock stopped, overcurrent (soft), speed amp saturation, motor overload, temporary overload, resolver error, speed over, error counter over, parameter setting error, software limit over, coordinate counter over, overrun, encoder disconnection, encoder communications error, absolute encoder backup error, absolute encoder checksum error, absolute encoder absolute error, absolute encoder over speed, encoder data not transmitted, BCD data error, present value undetermined, PTP data not set					

**Note:** 1. When using the 100-VAC-input Position Drivers in combination with the U-series or U-series UE type models, use 200-VAC Servo-motors (-HA, -TA, -VA, -XA, -H, or -V models).  
 2. For the monitor output, the monitor items and voltage polarity can be set by parameter UP-25 (monitor output selection).

# Dimensions

Note: All units are in millimeters unless otherwise indicated.

**200-VAC FND-X06H-SRT/-X12H-SRT**  
**100-VAC FND-X06L-SRT/-X12L-SRT**

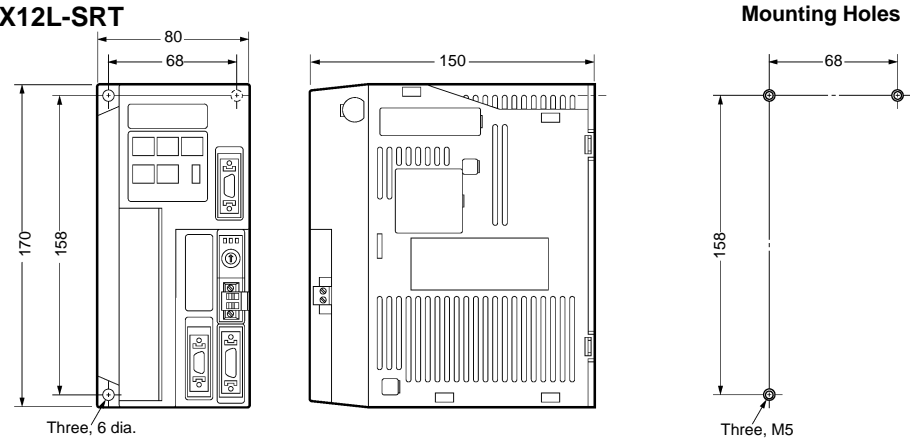

**200-VAC FND-X25H-SRT**

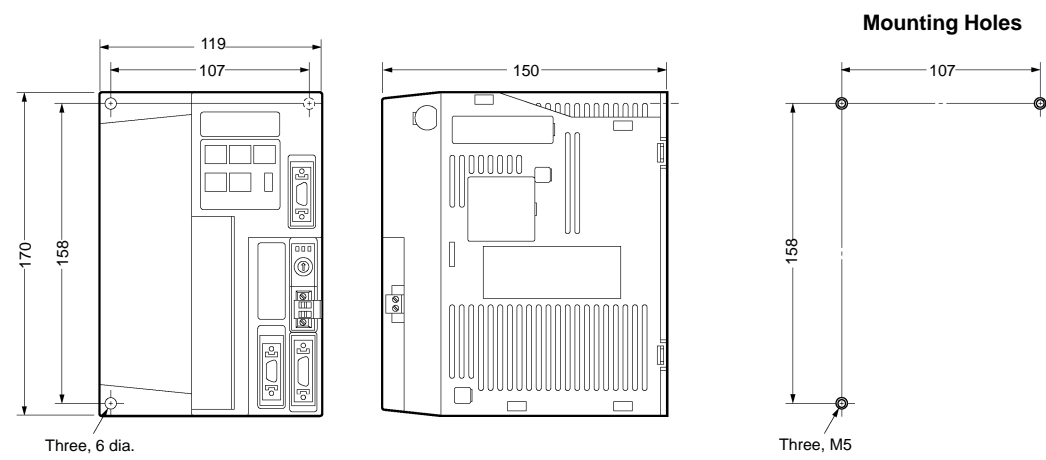

**200-VAC FND-X50H-SRT**

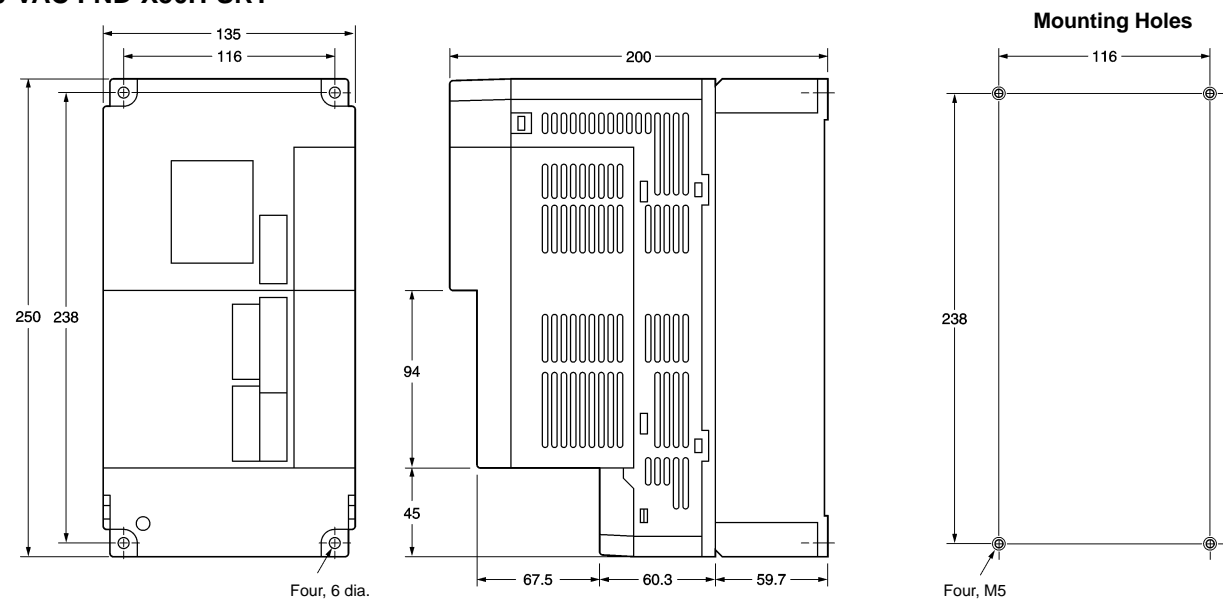

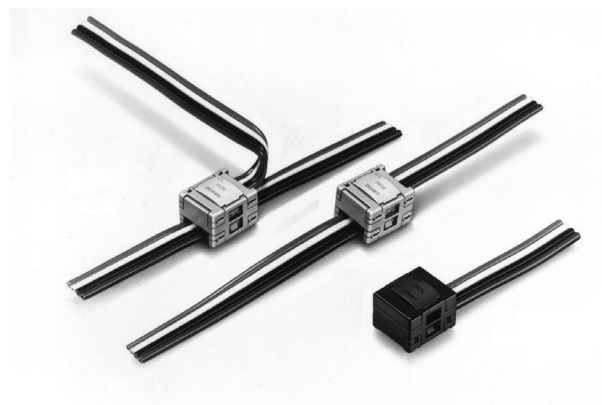

## Peripheral Devices

**Special Flat Cable Allows  
Communication Path Extension  
and T-branching with Ease**



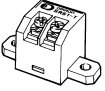

### Ordering Information

#### VCTF Cable Products

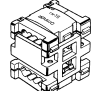
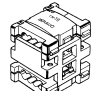

Product	Appearance	Model	Specification
Terminal-block Terminator		SRS1-T	Resistance: 100 Ω
T-branch Connector		XS2R-D427-5	Used to branch communications lines and power lines. (Waterproof specifications)
Connector Terminator (plug)		SRS2-1	Waterproof terminating resistance

#### Special Flat Cable Products

Product	Appearance	Model	Specification
Branch Connector		SCN1-TH4	Used with Special Flat Cable.
Extension Connector		SCN1-TH4E	Used with Special Flat Cable.
Connector Terminator		SCN1-TH4T	Used with Special Flat Cable.
Special Flat Cable		SCA1-4F10	100 m

**Note:** Branch Connectors and Extension Connectors are sold in blocks of 10 Units.

#### Four-core VCTF Cable Products

Product	Appearance	Model	Specification
Assembling Connector		XS2C-D4S7	Communications connector plug for 4-conductor VCTF cable
		XS2G-D4S7	Communications connector socket for 4-conductor VCTF cable

# Specifications

## ■ Ratings/Characteristics

Rated current	4 A
Contact resistance	20 mΩ max.
Insulation resistance	1,000 MΩ min. (at 500 VDC)
Withstand voltage	1,000 VAC for 1 min, leakage current: 1 mA max.
Cable pulling strength	50 N (5.1 kgf) min.
Operating temperature	-20°C to 70°C

## ■ Materials

Housing	PA66 resin (UL94V-2)
Cover	Branching and extension: Gray Terminator: Black
Contact	Phosphor bronze and nickel base, tin plated

# Dimensions

Note: All units are in millimeters unless otherwise indicated.

SCN1-TH4 Branch Connector  
SCN1-TH4E Extension Connector

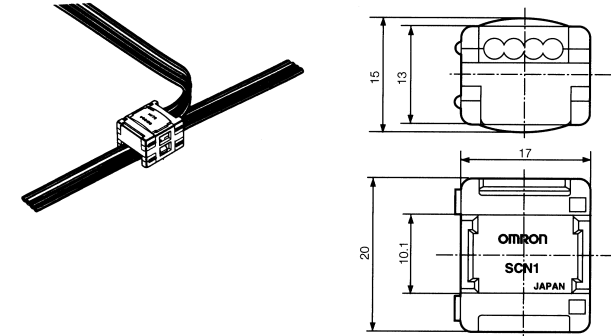

SCN1-TH4T Connector Terminator

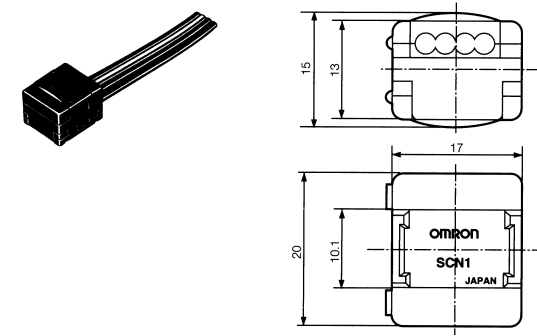

SRS1-T Terminal-block Terminator

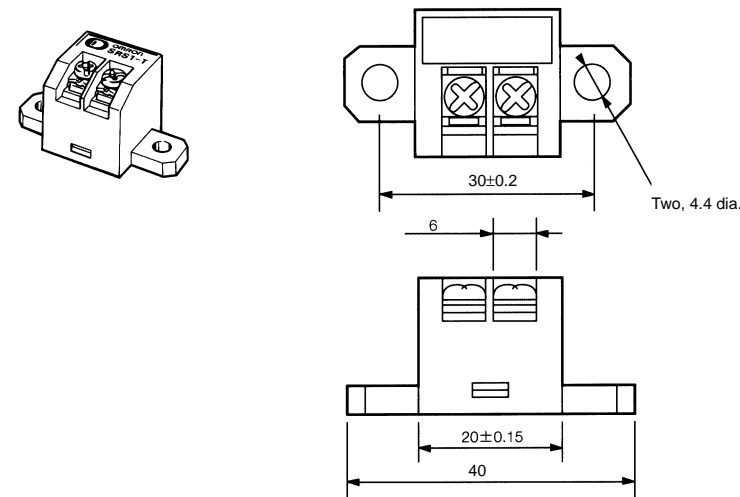

Mounting Holes

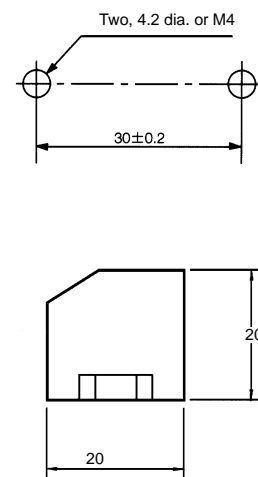



# Precautions

Refer to the *CompoBus/S Operation Manual (W266-E1)* before using the Unit.

## Ordering Information

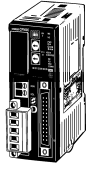
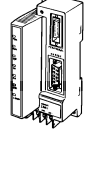
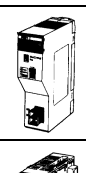
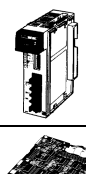

**Note:** Abbreviations for standards: U: UL, C: CSA, CE: EC Directive



### Master



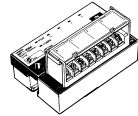
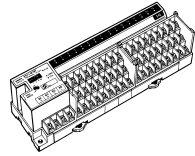
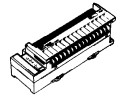

Product	Appearance	Model	Specifications	Standards
CPM2C CPU Units with CompoBus/S Master		CPM2C-S100C	Incorporates CPM2C CPU Unit and controller functions 6 inputs and 4 outputs (sinking)	U C CE (see note)
		CPM2C-S110C	Incorporates CPM2C CPU Unit and controller functions 6 inputs and 4 outputs (sourcing)	
Programmable Slaves		CPM2C-S100C-DRT	Incorporates CPM2C CPU Unit and controller functions 6 inputs and 4 outputs (sinking)	U C CE (see note)
		CPM2C-S110C-DRT	Incorporates CPM2C CPU Unit and controller functions 6 inputs and 4 outputs (sourcing)	
Master Control Units		SRM1-C01-V2	Stand-alone model with built-in controller functions No RS-232C port, 256 I/O points (128 inputs and 128 outputs)	U C CE (see note)
		SRM1-C02-V2	Stand-alone model with built-in controller functions No RS-232C port, 256 I/O points (128 inputs and 128 outputs)	
Master Units		C200HW-SRM21-V1	For CS1, C200HX/HG/HE (-ZE), and C200HS 128 inputs and 128 outputs (256 points in total)	U C CE (see note)
		CQM1-SRM21-V1	For CQM1 and CQM1H 64 inputs and 64 outputs (128 points in total)	
SYSMAC Boards with CompoBus/S Master		C200PC-ISA03-SRM	For C200HG-CPU43 128 inputs and 128 outputs (256 points in total)	CE (see note)
		C200PC-ISA13-SRM	For C200HX-CPU64 128 inputs and 128 outputs (256 points in total)	

**Note:** Long-distance communications mode is not supported.

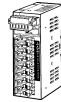
### Slave

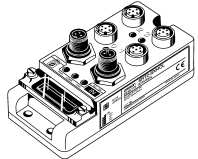
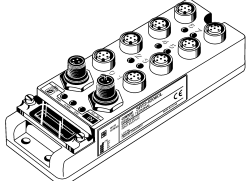
Product	Appearance	Model	Specifications	Standards
I/O Link Units		CPM2C-SRT21	For CPM2C 8 inputs and 8 outputs	CE (see note)
		CPM1A-SRT21	For CPM1A/CPM2A 8 inputs and 8 outputs	U C CE (see note)

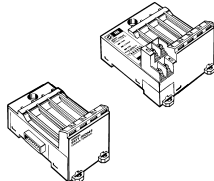
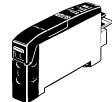
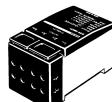
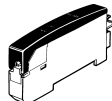
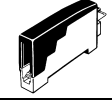
Product	Appearance	Model	Specifications	Standards	
Transistor Remote I/O Terminals		SRT2-ID04 SRT2-ID04-1 SRT2-OD04 SRT2-OD04-1	4 NPN inputs (+ common) 4 PNP inputs (– common) 4 NPN outputs (– common) 4 PNP outputs (+ common)	U C CE (see note)	
		SRT2-ID08 SRT2-ID08-1 SRT2-OD08 SRT2-OD08-1	8 NPN inputs (+ common) 8 PNP inputs (– common) 8 NPN outputs (– common) 8 PNP outputs (+ common)		
		SRT2-ID16 SRT2-ID16-1 SRT2-OD16 SRT2-OD16-1	16 NPN inputs (+ common) 16 PNP inputs (– common) 16 NPN outputs (– common) 16 PNP outputs (+ common)		
Transistor Remote I/O Terminals with 3-tier Terminal Block		SRT2-ID16T SRT2-ID16T-1 SRT2-MD16T SRT2-MD16T-1 SRT2-OD16T SRT2-OD16T-1	16 NPN inputs (+ common) 16 PNP inputs (– common) 16 NPN I/O points (inputs: + common; outputs: – common) 16 PNP I/O points (inputs: – common; outputs: + common) 16 NPN outputs (– common) 16 PNP outputs (+ common)	U C CE (see note)	
Relay-mounted Remote I/O Terminals		SRT2-ROC08	8 relay outputs	U C CE (see note)	
		SRT2-ROC16	16 relay outputs		
		SRT2-ROF08	8 power MOS FET relay outputs		
		SRT2-ROF16	16 power MOS FET relay outputs		
Transistor Remote I/O Terminals with Connectors		SRT2-ID32ML SRT2-ID32ML-1	32 NPN transistor inputs (+ common) 32 PNP transistor inputs (– common)	CE (see note)	
		SRT2-OD32ML SRT2-OD32ML-1 SRT2-MD32ML SRT2-MD32ML-1	32 NPN transistor outputs (– common) 32 PNP transistor outputs (+ common) 32 NPN transistor I/O points (inputs: + common; outputs: – common) 32 PNP transistor I/O points (inputs: – common; outputs: + common)		
		SRT2-VID08S SRT2-VID08S-1 SRT2-VOD08S SRT2-VOD08S-1	8 NPN transistor inputs (+ common) 8 PNP transistor inputs (– common) 8 NPN transistor outputs (– common) 8 PNP transistor outputs (+ common)	U C CE (see note)	
		SRT2-VID16ML SRT2-VID16ML-1 SRT2-VOD16ML SRT2-VOD16ML-1	16 NPN transistor inputs (+ common) 16 PNP transistor inputs (– common) 16 NPN transistor outputs (– common) 16 PNP transistor outputs (+ common)		
	---		SRT2-ATT01 SRT2-ATT02	Mounting hook A Mounting hook B	

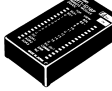
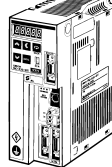

Product	Appearance	Model	Specifications	Standards	
Waterproof Transistor Terminals		SRT2-ID04CL SRT2-ID04CL-1 SRT2-OD04CL SRT2-OD04CL-1	4 NPN transistor inputs (+ common) 4 PNP transistor inputs (- common) 4 NPN transistor outputs (- common) 4 PNP transistor outputs (+ common)	CE (see note)	
		SRT2-ID08CL SRT2-ID08CL-1 SRT2-OD08CL SRT2-OD08CL-1	8 NPN transistor inputs (+ common) 8 PNP transistor inputs (- common) 8 NPN transistor outputs (- common) 8 PNP transistor outputs (+ common)		
Sensor Terminals		SRT2-ID08S SRT2-ND08S SRT2-OD08S	Sensor Terminals 8 inputs (NPN) 4 automatic teaching points (NPN) 8 outputs	---	
CompoBus/S Sensor Amplifier Terminals		SRT1-TID04S SRT1-TKD04S	4 communications points 4 communications points (to connect to the E3X-NM16)	---	
		SRT1-XID04S SRT1-XKD04S	4 expansion points 4 expansion points (to connect to the EX-NM16)		
Connection Units (see note)	Photoelectric Sensors		E3X-NT16 E3X-NT26 E3X-NH16 E3X-DA16	1-channel general-purpose teaching 1-channel multi-functional, general-purpose teaching 1-channel long-distance, high-precision bar-display teaching 1-channel digital model	U C CE (see note)
			E3X-NM16	4-channel multi-functional, general-purpose teaching	
	Proximity Sensors		E2CY-T16 E2C-T16	Aluminum detection Compact model with teaching function	U C
	Terminal Block Unit		E39-JID01	One input point	---
Analog Input Terminal		SRT2-AD04	1 to 4 inputs (set with DIP switch)	U C CE (see note)	
Analog Output Terminal		SRT2-DA02	1 or 2 outputs (set with DIP switch)		
Remote I/O Modules		SRT2-ID16P SRT2-OD16P	16 NPN inputs (+ common) 16 NPN outputs (- common)	---	
Position Drivers (for CompoBus/S)		FND-X06H-SRT FND-X12H-SRT FND-X25H-SRT FND-X50H-SRT FND-X06L-SRT FND-X12L-SRT	6 A at 200-VAC input 12 A at 200-VAC input 25 A at 200-VAC input 50 A at 200-VAC input 6 A at 100-VAC input 12 A at 100-VAC input	U CE (see note) cUL	

**Note:** The Position Driver cannot be used in long-distance communications mode.







**Peripheral Devices**



**VCTF Cable Products**

Product	Appearance	Model	Specifications	Standards
Terminal-block Terminator		SRS1-T	100 Ω	---
T-branch Connector		XS2R-D427-5	Waterproof	
Connector Terminator (plug)		SRS2-1	Waterproof terminator	

**Special Flat Cable Products**

Product	Appearance	Model	Specifications	Standards
Branch Connector		SCN1-TH4	Connector for Special Flat Cable	---
Extension Connector		SCN1-TH4E		
Connector Terminator		SCN1-TH4T		
Special Flat Cable		SCA1-4F10	100 m	

**Four-conductor VCTF Cable Products**

Product	Appearance	Model	Specifications	Standards
Assembling Connector		XS2C-D4S7	Connector plug for 4-conductor VCTF cable communications	---
		XS2G-D4S7	Connector socket for 4-conductor VCTF cable communications	

**Note: Information on EC Directives**

Individual OMRON products that comply with EC Directives conform to the common emission standards of EMC Directives. However, the emission characteristics of these products installed on customers' equipment may vary depending on the configuration, wiring, layout, and other conditions of the control panel used. For this reason, customers are requested to check whether the emission characteristics of the entire machine or equipment comply with the EMC Directives.

## X-ON Electronics

Largest Supplier of Electrical and Electronic Components

*Click to view similar products for [DIN Rail Terminal Blocks](#) category:*

*Click to view products by [Omron](#) manufacturer:*

Other Similar products are found below :

[00110420202](#) [8WA1011-1BH23](#) [8WA1011-1EF20](#) [91.010](#) [9102100000](#) [91.040](#) [9123140000](#) [9123140001](#) [RBO 5-T-B-HEX](#) [1333564](#) [DP25-GY-ND](#) [1431306](#) [1433306](#) [90.070](#) [91.020](#) [912314](#) [260-301\\_NR](#) [2757571](#) [280-331](#) [280-560](#) [280-564](#) [281-611/281-542](#) [281-673/281-411](#) [281-994](#) [283-317](#) [283-607](#) [284-691](#) [2909798](#) [264-724](#) [264-726](#) [280-530](#) [280-555](#) [280-619](#) [281-610](#) [281-622/281-417](#) [284-317](#) [284-601](#) [2907033](#) [3048496](#) [5542152](#) [35956](#) [USK 10](#) [102510](#) [1025100000](#) [5520682](#) [5607102](#) [EMH 25-ZE30](#) [591620-2](#) [UM 45-SEFE M.NUT BK 1-591651-1](#)