

LED Control IC W2RF004RM

Most Suitable IC for Controlling LED Effects within Applications

- Free-running PWM gradation control, with up to 1,024 levels, enables the representation of beautiful fade-in and fade-out effects.
- CPU load can be reduced by controlling lighting gradation and speed.
- Up to 49 pieces of this IC can be connected on the same serial bus communication line. Device group setting is also possible.
- Independent control of up to 9 Lines.
- Use with Omron's W2RV005RM Constant Current IC to directly drive multiple LED's in series.
- RoHS Compliant

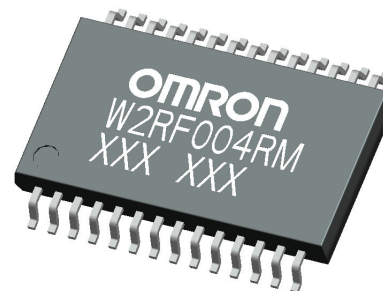

Ordering Information

Description	Model
LED Control IC	W2RF004RM

Specifications

Absolute Maximum Ratings (Ta = 25°C)

Item	Symbol	Rating
Supply Voltage	V _{DD}	-0.3 to 7.0 V
Input Voltage	V _{IN}	-0.3 to V _{DD} + 0.3 ≤ 7.0 V
Communication Output Voltage (SCL-O, SDA-O)	V _{SOUT}	-0.3 to V _{DD} + 0.3 ≤ 7.0 V
Driving Output Voltage	V _{DOUT}	-0.3 to 20 V
Driving Output Current/pin (See note 1)	I _{DOUT}	50 mA (when V _{DD} = 5.0 V)
		30 mA (when V _{DD} = 3.3 V)
Power Dissipation	Pd	1.06 W (See note 2)
Operating Temperature	T _{OPR}	-20 to 85 °C
Storage Temperature	T _{STG}	-40 to 150 °C

Note: 1. Take the power consumption and power dissipation rating into consideration.

- 2.** When implemented on a standard board (70 x 70 x 1.6 mm, Cu 3%, Single-sided glass epoxy board). The value reduces at a rate of about 8.48 mW/°C when the IC is used at Ta = 25°C or higher.

Recommended Operating Conditions

Item	Symbol	Rating
Supply Voltage	V _{DD}	3.0 to 5.5 V
Input Voltage	V _{IN}	0 to V _{DD} V
Communication Output Current (SCL-O, SDA-O)	I _{SOUT}	-10 to 10 mA
Communication Clock Frequency (SCL-I)	f _{SCL}	Max. 5 MHz (See note 1)

Note: 1. Take the timing characteristics into consideration.

DC Electrical Characteristics (Ta = 25°C, V_{DD} = 5V)

Item	Symbol	Condition	Spec.			Unit	Applicable terminal
			Min.	Typ.	Max.		
High-level Input Voltage	V _{IH}	---	V _{DD} × 0.7	---	---	V	SDA-I, SCL-I, \overline{RST} , INV, ADRA0 to 2, ADRB0 to 2
Low-level Input Voltage	V _{IL}	---	---	---	V _{DD} × 0.3	V	
High-level Communication Output Voltage	V _{SOH}	I _{OUT} = -10 mA	V _{DD} - 0.5	---	---	V	SDA-O, SCL-O
Low-level Communication Output Voltage	V _{SOL}	I _{OUT} = 10 mA	---	---	0.5	V	
Driving Output Voltage 1	V _{DO1}	I _{OUT} = 50 mA	---	0.27	0.60	V	OUTA0 to 2 OUTB0 to 2 OUTC0 to 2
Driving Output Voltage 2	V _{DO2}	I _{OUT} = 20 mA	---	0.10	0.22	V	
Driving Output Leakage Current	I _{DOZ}	V _{OUT} = 5 V	---	---	1.0	μA	
Operating Current Consumption	I _{DD}	Total Output: I _{OUT} = 50 mA	---	2.4	4.1	mA	V _{DD}

Timing Characteristics (Ta = 25°C, VDD = 5V)

Item	Symbol	Condition	Spec.			Unit	Applicable terminal
			Min.	Typ.	Max.		
Driving Output PWM Cycle	$T_{P_{PWM}}$	---	3.88	4.00	4.12	ms	OUTA0 to 2 OUTB0 to 2 OUTC0 to 2
Communication Clock Pulse Width	t_{SCL}	---	100	---	---	ns	SCL-I
Setup Time	t_{SET}	---	50	---	---	ns	SDA-I, SCL-I
Hold Time	t_{HLD}	---	50	---	---	ns	

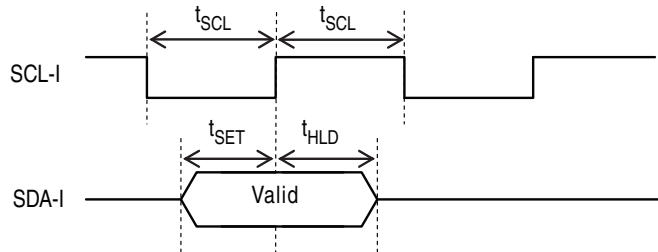
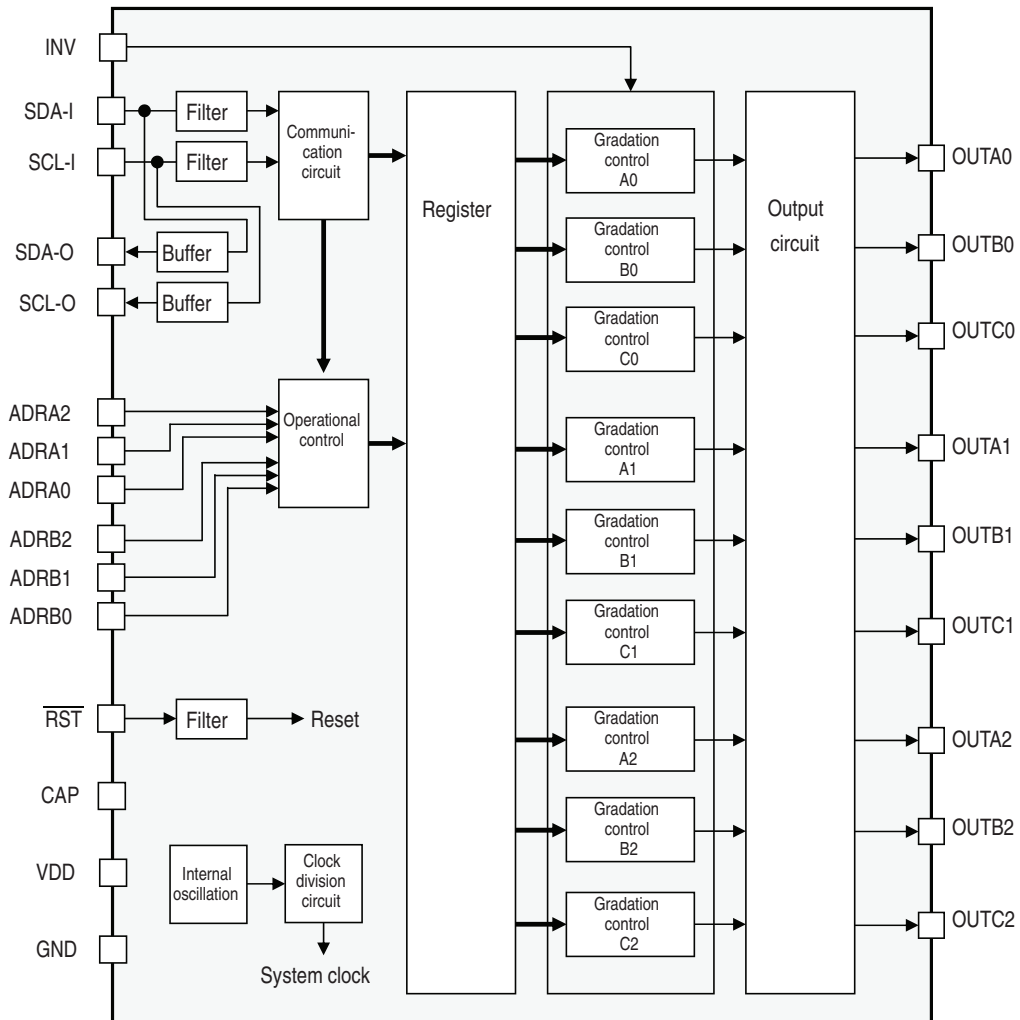

Fig. 1 Input timing waveforms

Engineering Data

Block Diagram



Terminal Designation

Terminal Number	Terminal Name	Description	I/O	Logic	Function
1	TST1	Not used (See note 3)	- - -		
2	TST2	Not used (See note 3)	- - -		
3	SDA-O	Serial data buffer output	O		CMOS
4	SCL-O	Serial clock buffer output	O		
5	SDA-I	Serial data input	I		CMOS, filter
6	SCL-I	Serial clock input	I		
7	$\overline{\text{RST}}$	Reset (See note 1)	I	L: Reset	CMOS, filter, pull-up
8	V_{DD}	Power source	P		
9	CAP	Capacitor (See note 2)	- - -		
10	GND	Ground	P		
11	ADRA2	Device address A2	I	Refer to Operaton section (See note 4)	CMOS
12	ADRA1	Device address A1	I		
13	ADRA0	Device address A0	I		
14	ADRB2	Device address B2	I		
15	ADRB1	Device address B1	I		
16	ADRB0	Device address B0	I		
17	INV	Output inversion	I		
18	GND	Ground	P		
19	OUTA0	Output A0	O		N-ch open drain
20	OUTB0	Output B0	O		
21	OUTC0	Output C0	O		
22	OUTA1	Output A1	O		
23	OUTB1	Output B1	O		
24	OUTC1	Output C1	O		
25	OUTA2	Output A2	O		
26	OUTB2	Output B2	O		
27	OUTC2	Output C2	O		
28	GND	Ground	P		

- Note:**
1. The $\overline{\text{RST}}$ terminal is connected to an internal 100 k Ω pull-up resistor. When this terminal is not used, connect a 0.1 μF capacitor between the terminal and ground to prevent misoperation at power-on.
 2. Connect the CAP terminal to a capacitor for smoothing power supply. Connect a 0.1 μF capacitor between the terminal and GND.
 3. Always leave the TST1 and TST2 terminals open.
 4. Leave unused output terminals open.

Operation

Functional Overview

Receiving Commands

The IC receives commands with two-wire serial communication to control 9 LED lines. Commands are received in a 40-bits-per-command communication format.

Gradation Control

The lighting of the 9 LED lines is controlled individually or by group with 16-level lighting gradation and 32-level lighting speed. The exponential control of output duty cycle allows lighting gradation that matches the human visual characteristics. In addition, the specification of lighting speed allows fade-in and fade-out with up to 1,024 levels.

Number of Control Lines

The IC has two device address lines, each of which can be configured in seven ways by terminal configuration. This provides up to 49 patterns of device address configuration, allowing up to 441 lines to be controlled on the same communication line. Two device address lines can be combined to configure a device group.

Communication Specifications

Input signals to SDA-I and SCL-I are input via the filter circuit (0.1μs delay) to the communication circuit. An SDA-I signal that is input to the communication circuit is taken in as serial data at the rising edge of an SCL-I signal. When serial data is received in a different format from the communication format, the data will be invalid.

When the START signal, "11111111" is detected, the communication circuit takes in data as new serial data, whether it is on stand-by or in the middle of intake of serial data.

Input signals to SDA-I and SCL-I will be output via the asynchronous buffer to SDA-O and SCL-O without going through the filter circuit.

Communication Format

bit	1	2	3	4	5	6	7	8	9	10	11	12	13	14	15	16	17	18	19	20	21	22	23	24	25	26	27	28	29	30	31	32	33	34	35	36	37	38	39	40			
SCL-I	[Timing diagram showing SCL-I signal]																																										
SDA-I	1	1	1	1	1	1	1	1	1	0	0	0							0																					0	X	X	X
Name	START									(Break)	Device ID	Device address A	Device address B	(Break)	Control	Output address	(Break)	Lighting speed	Lighting gradation	END																							
										(Break)	Device selection data dvc_dat[7:0]			(Break)	Control data ctrl_dat[6:0]		(Break)	Lighting data light_dat[8:0]																									

Description of Communication Format

Device Selection Data	Device ID	Device-specific ID (Fixed to "00" for this IC)
	Device Address A	Specified with the ADRA0 to 2 terminals
	Device Address B	Specified with the ADRB0 to 2 terminals
Control Data	Control	Specifies control (data saving / immediate reflection)
	Output Address	Specifies the terminal to output (Individual specification and collective specification are possible)
Lighting Data	Lighting Speed	Specifies changing speed of free-running gradation control (32 levels)
	Lighting Gradation	Specifies the brightness of lighting (16 levels)

Control Command

Device Selection Data (8 bits)

Device selection data dvc_dat (7:0)							
Device ID		Device Address A			Device Address B		
0	0	ADRA2	ADRA1	ADRA0	ADRB2	ADRB1	ADRB0

The device ID is fixed. The correspondence between the device addresses A and B and the setting terminals ADRA0 to 2 and ADRB0 to 2 is shown in the table. (Setting "L"...Data "0". Setting "H"...Data "1").

When ADRA0 to 2 = "111", the device address A line is specified collectively, and when ADRB0 to 2 = "111", the device address B line is specified collectively.

Because up to 7 addresses can be specified for each of device address A and device address B, their combination allows the specification of up to 49 addresses.

Control Data (7 bits)

Control data ctrl_dat (6:0)						
Control	Output Address					
ctrl	o_adr(5)	o_adr(4)	o_adr(3)	o_adr(2)	o_adr(1)	o_adr(0)

The control signal, 'ctrl', activates the operational control shown in the following table.

- When ctrl = "0", latch operation is activated, in which data is only stored in latch registers and will not be reflected in the output.
- When ctrl = "1", load operation is activated, in which data is stored in the specified latch registers and the data of the latch registers in all addresses will be stored in the load registers.

Control (ctrl)	Operational Control
0	Latch
1	Load

The output terminals in the following table are specified with the output address o_adr(5:0)

Output Address o_adr (5:0)						Output Terminal
(5)	(4)	(3)	(2)	(1)	(0)	
0	0	0	0	0	0	OUTA0
0	0	0	0	0	1	OUTA1
0	0	0	0	1	0	OUTA2
0	0	0	0	1	1	(No terminal)
0	0	0	1	0	0	(No terminal)
0	0	0	1	0	1	(No terminal)
0	0	0	1	1	0	(No terminal)
0	0	0	1	1	1	(No terminal)
0	0	1	0	0	0	OUTB0
0	0	1	0	0	1	OUTB1
0	0	1	0	1	0	OUTB2
0	0	1	0	1	1	(No terminal)
0	0	1	1	0	0	(No terminal)
0	0	1	1	0	1	(No terminal)
0	0	1	1	1	0	(No terminal)
0	0	1	1	1	1	(No terminal)
0	1	0	0	0	0	OUTC0
0	1	0	0	0	1	OUTC1
0	1	0	0	1	0	OUTC2
0	1	0	0	1	1	(No terminal)
0	1	0	1	0	0	(No terminal)
0	1	0	1	0	1	(No terminal)
0	1	0	1	1	0	(No terminal)
0	1	0	1	1	1	(No terminal)
0	1	1	0	0	0	OUTA0, OUTA2
0	1	1	0	0	1	OUTA1
0	1	1	0	1	0	OUTB0, OUTB2
0	1	1	0	1	1	OUTB1
0	1	1	1	0	0	OUTC0, OUTC2
0	1	1	1	0	1	OUTC1
0	1	1	1	1	0	OUTA0, OUTA2 OUTB0, OUTB2 OUTC0, OUTC2
0	1	1	1	1	1	OUTA1 OUTB1 OUTC1

Output Address o_adr (5:0)						Output Terminal
(5)	(4)	(3)	(2)	(1)	(0)	
1	0	0	0	0	0	OUTA0, OUTA1
1	0	0	0	0	1	OUTA2
1	0	0	0	1	0	OUTB0, OUTB1
1	0	0	0	1	1	OUTB2
1	0	0	1	0	0	OUTC0, OUTC1
1	0	0	1	0	1	OUTC2
1	0	0	1	1	0	OUTA0, OUTA1 OUTB0, OUTB1 OUTC0, OUTC1
1	0	0	1	1	1	OUTA2 OUTB2 OUTC2
1	0	1	0	0	0	OUTA0, OUTA1, OUTA2
1	0	1	0	0	1	(No terminal)
1	0	1	0	1	0	OUTB0, OUTB1, OUTB2
1	0	1	0	1	1	(No terminal)
1	0	1	1	0	0	OUTC0, OUTC1, OUTC2
1	0	1	1	0	1	(No terminal)
1	0	1	1	1	0	OUTA0, OUTA1, OUTA2 OUTB0, OUTB1, OUTB2 OUTC0, OUTC1, OUTC2
1	0	1	1	1	1	(No terminal)
1	1	0	0	0	0	OUTA0, OUTB0, OUTC0
1	1	0	0	0	1	OUTA1, OUTB1, OUTC1
1	1	0	0	1	0	OUTA2, OUTB2, OUTC2
1	1	0	0	1	1	(No terminal)
1	1	0	1	0	0	(No terminal)
1	1	0	1	0	1	(No terminal)
1	1	0	1	1	0	(No terminal)
1	1	0	1	1	1	(No terminal)
1	1	1	0	0	0	(No terminal)
1	1	1	0	0	1	All OUTA
1	1	1	0	1	0	All OUTB
1	1	1	0	1	1	All OUTA, All OUTB
1	1	1	1	0	0	All OUTC
1	1	1	1	0	1	All OUTA, All OUTC
1	1	1	1	1	0	All OUTB, All OUTC
1	1	1	1	1	1	All OUTA, All OUTB, All OUTC

Lighting Data (9 bits)

Lighting data light_dat (8:0)								
Lighting speed					Lighting gradation			
spd(4)	spd(3)	spd(2)	spd(1)	spd(0)	brt(3)	brt(2)	brt(1)	brt(0)

Lighting is controlled in each line with the values of the load registers. In lighting control, the gradation changes to the specified one at the specified lighting speed

The Lighting speed follows the table below.

The change time is specified with 5 bits;

Lighting Speed spd(4:0)					Change time per 1/15 of brightness	Change time from 0/15 to 15/15 of brightness (and vice versa)
(4)	(3)	(2)	(1)	(0)		
0	0	0	0	0	Less than 60 μs	Less than 1 ms
0	0	0	0	1	8.5 ms	0.128 s
0	0	0	1	0	10.7 ms	0.160 s
0	0	0	1	1	12.8 ms	0.192 s
0	0	1	0	0	14.9 ms	0.224 s
0	0	1	0	1	17.1 ms	0.256 s
0	0	1	1	0	21.3 ms	0.320 s
0	0	1	1	1	25.6 ms	0.384 s
0	1	0	0	0	29.9 ms	0.448 s
0	1	0	0	1	34.1 ms	0.512 s
0	1	0	1	0	42.7 ms	0.640 s
0	1	0	1	1	51.2 ms	0.768 s
0	1	1	0	0	59.7 ms	0.896 s
0	1	1	0	1	68.3 ms	1.024 s
0	1	1	1	0	85.3 ms	1.280 s
0	1	1	1	1	102 ms	1.536 s
1	0	0	0	0	119 ms	1.792 s
1	0	0	0	1	137 ms	2.048 s
1	0	0	1	0	171 ms	2.560 s
1	0	0	1	1	205 ms	3.072 s
1	0	1	0	0	239 ms	3.584 s
1	0	1	0	1	273 ms	4.096 s
1	0	1	1	0	341 ms	5.120 s
1	0	1	1	1	410 ms	6.144 s
1	1	0	0	0	478 ms	7.168 s
1	1	0	0	1	546 ms	8.192 s
1	1	0	1	0	683 ms	10.24 s
1	1	0	1	1	819 ms	12.29 s
1	1	1	0	0	956 ms	14.34 s
1	1	1	0	1	1,092 ms	16.38 s
1	1	1	1	0	1,365 ms	20.48 s
1	1	1	1	1	1,638 ms	24.58 s

Note: The change time per 1/15 of brightness represents the time required for a change from, for example, 10/15 to 11/15 of brightness.

The change time from 0/15 to 15/15 of brightness and vice versa represents the time required for a change from 0/15 of brightness (light OFF) to 15/15 of brightness (light completely ON). However, these times are median values and depend on the driving output PWM cycle.

The Lighting gradation follows the table below.

The brightness is specified with 4 bits;

Lighting Gradation brt(3:0)				Brightness	PWM duty ratio (reference)
(3)	(2)	(1)	(0)		
0	0	0	0	0/15 (light OFF)	0 %
0	0	0	1	1/15	0.42 %
0	0	1	0	2/15	0.84 %
0	0	1	1	3/15	1.25 %
0	1	0	0	4/15	1.78 %
0	1	0	1	5/15	2.61 %
0	1	1	0	6/15	3.76 %
0	1	1	1	7/15	5.42 %
1	0	0	0	8/15	7.96 %
1	0	0	1	9/15	11.3 %
1	0	1	0	10/15	16.7 %
1	0	1	1	11/15	23.3 %
1	1	0	0	12/15	35.2 %
1	1	0	1	13/15	48.4 %
1	1	1	0	14/15	73.4 %
1	1	1	1	15/15 (Light completely ON)	100 %

■ Functional Terminals/Setting Terminals

ADR terminals	The ADRA terminal set device address A and device address B, respectively. For "H" setting, connect the terminal to V_{DD} and for "L" setting, connect the terminal to GND
INV terminal	This terminal sets the polarity of OUT terminal. <ul style="list-style-type: none"> When the terminal is used with "L" as active (e.g., for directly driving an LED), connect the terminal to V_{DD} When the terminal is used with the "H" as active (e.g., for driving an LED with a driving transistor), connect the terminal to GND.
RST terminal	When the voltage of the RST terminal becomes "L", the internal circuit will be reset and the output will be open.

■ Application Example

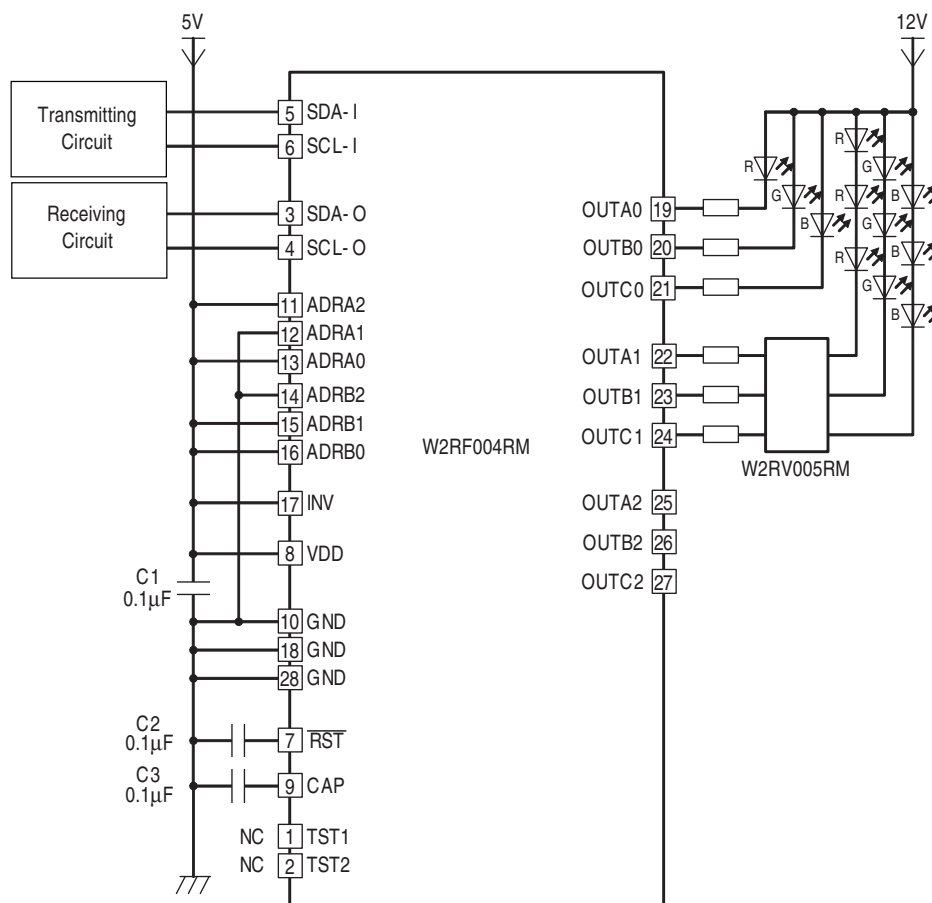

Dimensions

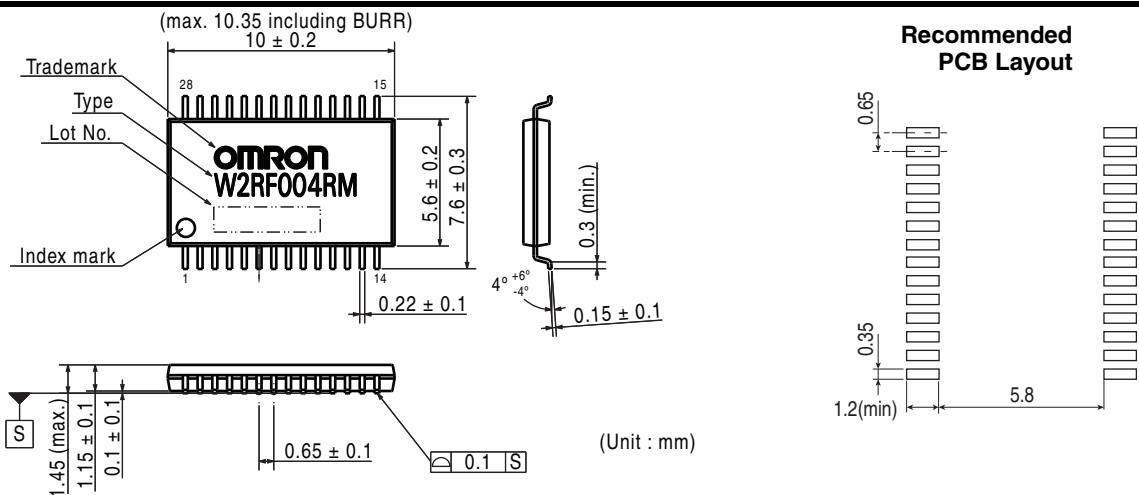

Tape Packaging

Packaging style: Embossed taping

Packaging quantity: 2,000 pcs/reel

Reel Dimensions

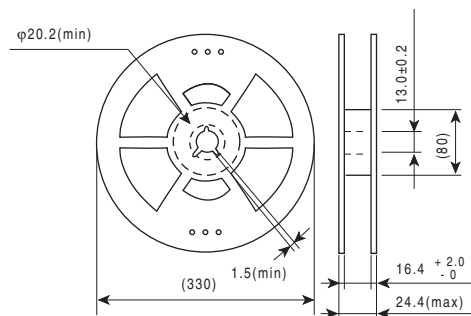

Direction of Insertion

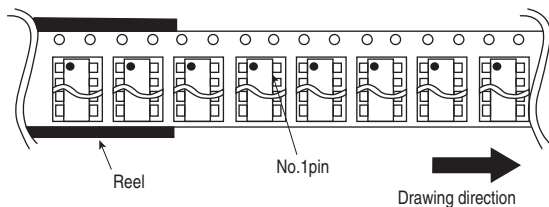

Embossed Tape Dimensions

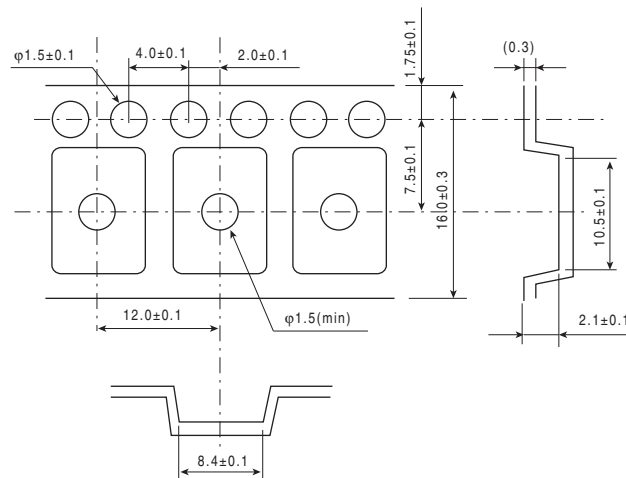

Precautions for Use

■ Correct Use

- The absolute maximum rating is the limit value which should not be exceeded even in a flash. Exceeding this value can cause deterioration of the characteristics or complete failure of the IC.
- Check the operation at the communication frequency to be used before using the device.
- Sufficiently take into consideration the static electricity, chattering and voltage of the input to be connected when determining each input circuit.
- Although the device contains an ESD protection circuit, static electricity that exceeds the function may damage the device. When handling the device, exercise due caution by, for example, grounding the human body.
- Due to potential damage, do not use product that has been dropped or that has come into contact with water.

■ Recommended Reflow Conditions

Allowable Temperature Profile Conditions

Product mounting method should be by Reflow and we recommend the following temperature profile. Reflow no more than two times, maximum.

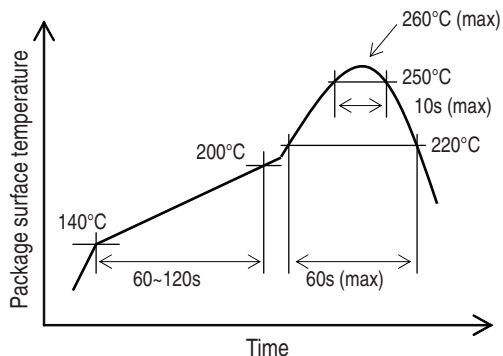

Storage Conditions before Mounting

Moisture absorption by the plastic package will increase the possibility of faults, such as cracks; therefore, take enough care for storage.

Storage Conditions	Period
5 to 30°C, 40 to 70%RH	One Year

■ RoHS Directive Compliance

Models that are indicated as being RoHS compliant are free of the following six substances.

Lead:	1,000 ppm max.
Mercury:	1,000 ppm max.
Cadmium:	100 ppm max.
Hexavalent chromium:	1,000 ppm max.
PBB:	1,000 ppm max.
PBDE:	1,000 ppm max.

■ Lot Code Indication

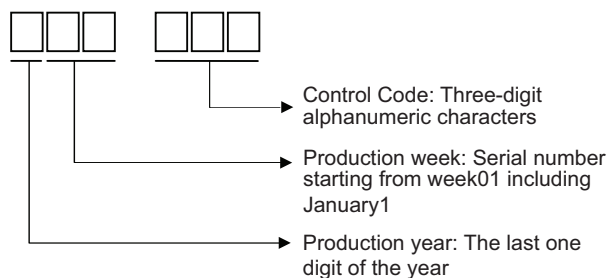

All sales are subject to Omron Electronic Components LLC standard terms and conditions of sale, which can be found at http://www.components.omron.com/components/web/webfiles.nsf/sales_terms.html

ALL DIMENSIONS SHOWN ARE IN MILLIMETERS.
To convert millimeters into inches, multiply by 0.03937. To convert grams into ounces, multiply by 0.03527.

OMRON[®]

**OMRON ELECTRONIC
COMPONENTS LLC**

55 E. Commerce Drive, Suite B
Schaumburg, IL 60173

847-882-2288

OMRON ON-LINE

Global - <http://www.omron.com>

USA - <http://www.components.omron.com>

Cat. No. OCB-AM AM-W2-AU-002(E) 08/12 Specifications subject to change without notice Printed in USA

X-ON Electronics

Largest Supplier of Electrical and Electronic Components

Click to view similar products for [LED Lighting Drivers](#) category:

Click to view products by [Omron](#) manufacturer:

Other Similar products are found below :

[LV5235V-MPB-H](#) [MB39C602PNF-G-JNEFE1](#) [MIC2871YMK-T5](#) [AL1676-10BS7-13](#) [AL1676-20AS7-13](#) [AP5726WUG-7](#) [ICL8201](#)
[IS31BL3228B-UTLS2-TR](#) [IS31BL3506B-TTLS2-TR](#) [AL3157F-7](#) [AP5725FDCG-7](#) [AP5726FDCG-7](#) [LV52204MTTBG](#) [AP5725WUG-7](#)
[STP4CMPQTR](#) [NCL30086BDR2G](#) [CAT4004BHU2-GT3](#) [LV52207AXA-VH](#) [AP1694AS-13](#) [TLE4242EJ](#) [AS3688](#) [IS31LT3172-GRLS4-TR](#)
[TLD2311EL](#) [KTD2694EDQ-TR](#) [KTZ8864EJAA-TR](#) [IS32LT3174-GRLA3-TR](#) [MP2488DN-LF-Z](#) [NLM0010XTSA1](#) [AL1676-20BS7-13](#)
[ZXLD1370QESTTC](#) [MPQ7220GF-AEC1-P](#) [MPQ7220GR-AEC1-P](#) [MPQ4425BGJ-AEC1-P](#) [MPQ7220GF-AEC1-Z](#) [MPQ7220GR-AEC1-Z](#)
[MPQ4425BGJ-AEC1-Z](#) [NCL30486A2DR2G](#) [IS31FL3737B-QFLS4-TR](#) [IS31FL3239-QFLS4-TR](#) [KTD2058EUAC-TR](#) [KTD2037EWE-TR](#)
[DIO5662ST6](#) [IS31BL3508A-TTLS2-TR](#) [KTD2026BEWE-TR](#) [MAX20052CATC/V+](#) [MAX25606AUP/V+](#) [BD6586MUV-E2](#) [BD9206EFV-E2](#) [BD9416FS-E2](#) [LYT4227E](#)