

# XF FPC Connectors

Low-profile FPC connectors with 0.3-mm/0.4-mm/0.5-mm pitch



### Expanded Variety

New Series Additions

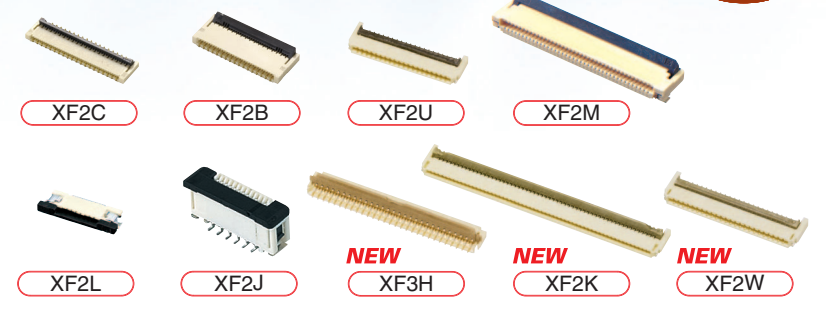

# FPC See How Far FPC Connectors Have Advanced

FPC Connectors must offer easy operation and secure mounting in tight working spaces. The rotary backlock construction of the XF Series solves FPC mounting problems and significantly enhances work efficiency and reliability.

## XF Series

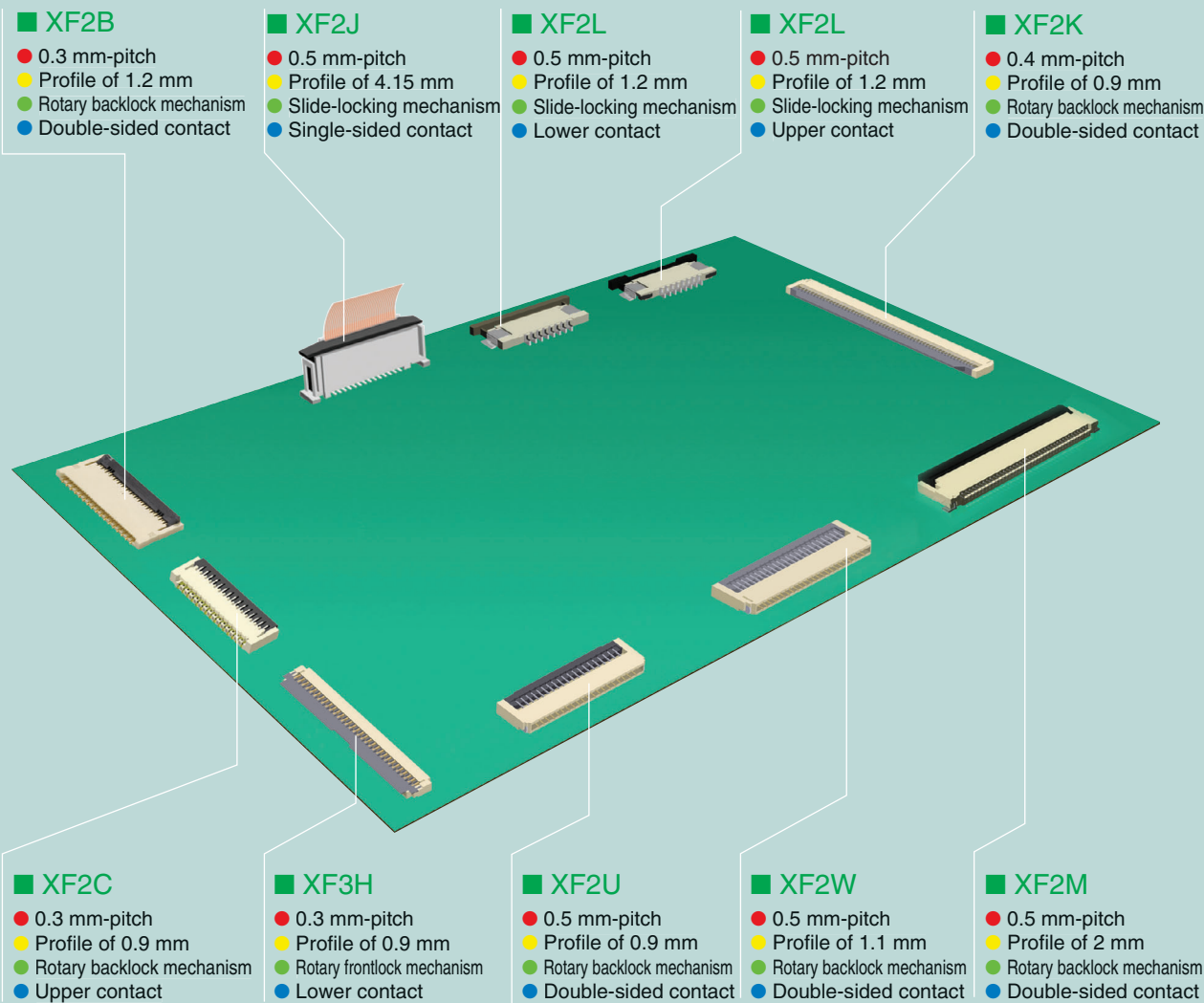

## Applications

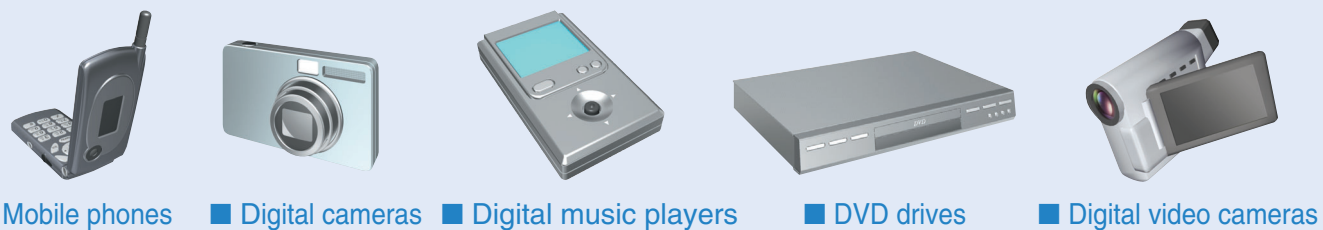

# INDEX

## Product Overview

Model	Lock mechanism	Pitch	On-board profile	Depth	Applicable FPC thickness	Contact type	Page
XF2C	Rotary backlock	0.3 mm	0.9 mm	4.0 mm	0.12 mm	Upper contact	P6
XF2B	Rotary backlock	0.3 mm	1.2 mm	5.5 mm	0.2 mm	Double-sided contact (See note 1.)	P7
XF3H	Rotary frontlock	0.3 mm	0.9 mm	3.2 mm	0.2 mm	Lower contact	P9
XF2K	Rotary backlock	0.4 mm	0.9 mm	3.5 mm	0.2 mm	Double-sided contact	P11
XF2U	Rotary backlock	0.5 mm	0.9 mm	3.5 mm	0.2 mm	Double-sided contact	P12
XF2W	Rotary backlock	0.5 mm	1.1 mm	3.5 mm	0.3 mm	Double-sided contact	P13
XF2M	Rotary backlock	0.5 mm	2.0 mm (See note 2.)	5.9 mm (See note 2.)	0.3 mm	Double-sided contact	P15
XF2L	Slide lock	0.5 mm	1.2 mm	3.5 mm	0.3 mm	Upper/lower contact	P17
XF2J	Slide lock	0.5 mm	4.15 mm	3.4 mm	0.3 mm	Single-sided contact	P19

Note 1: Models with 61 pins have upper contacts.  
 Note 2: Specifications for models with 55 pins and those with 60 pins differ.

## Model Number Legend

Use this legend when determining the product specifications from the model number. Choose from the model numbers listed in this catalog when ordering.

XF       -             -          -         

(1) (2) (3) (4) (5) (6) (7) (8)

- |   |   |  |
|---|---|--|
| (1) Series Classification<br>2B, 2C, 2J, 2K, 2L, 2M, 2U, 2W, 3H   | (5) Applicable FPC Thickness<br>1: 0.3 mm<br>3: 0.2 mm<br>4: 0.12 mm<br>5: 0.15 mm  | (7) Plating<br>A: Au   |
| (2) Number of Signal Contact Pins   | (6) Terminal Arrangement<br>□: Standard<br>1: Staggered arrangement (forward arrangement)<br>2: Staggered arrangement (reverse arrangement) | (8) Special Specification<br>R100: 100 units (small lot)<br><b>Note:</b> Supported only for the XF2M.<br>E: Easy lock type<br>H: For multiple pins |
| (3) Contact Arrangement<br>1: One-row, double-sided contact<br>2: One-row, single-sided contact (including upper contact and top entry)<br>3: One-row, single-sided contact (lower contact)<br>4: Two-row, double-sided contact<br>5: Two-row, single-sided contact | (4) Terminal Shape<br>4: SMT terminals (top entry)<br>5: SMT terminals (side entry)   |  |

# FPC See How Far FPC Connectors Have Advanced

FPC Connectors must offer easy operation and secure mounting in tight working spaces. The rotary backlock construction of the XF Series solves FPC mounting problems and significantly enhances work efficiency and reliability.

## XF Series

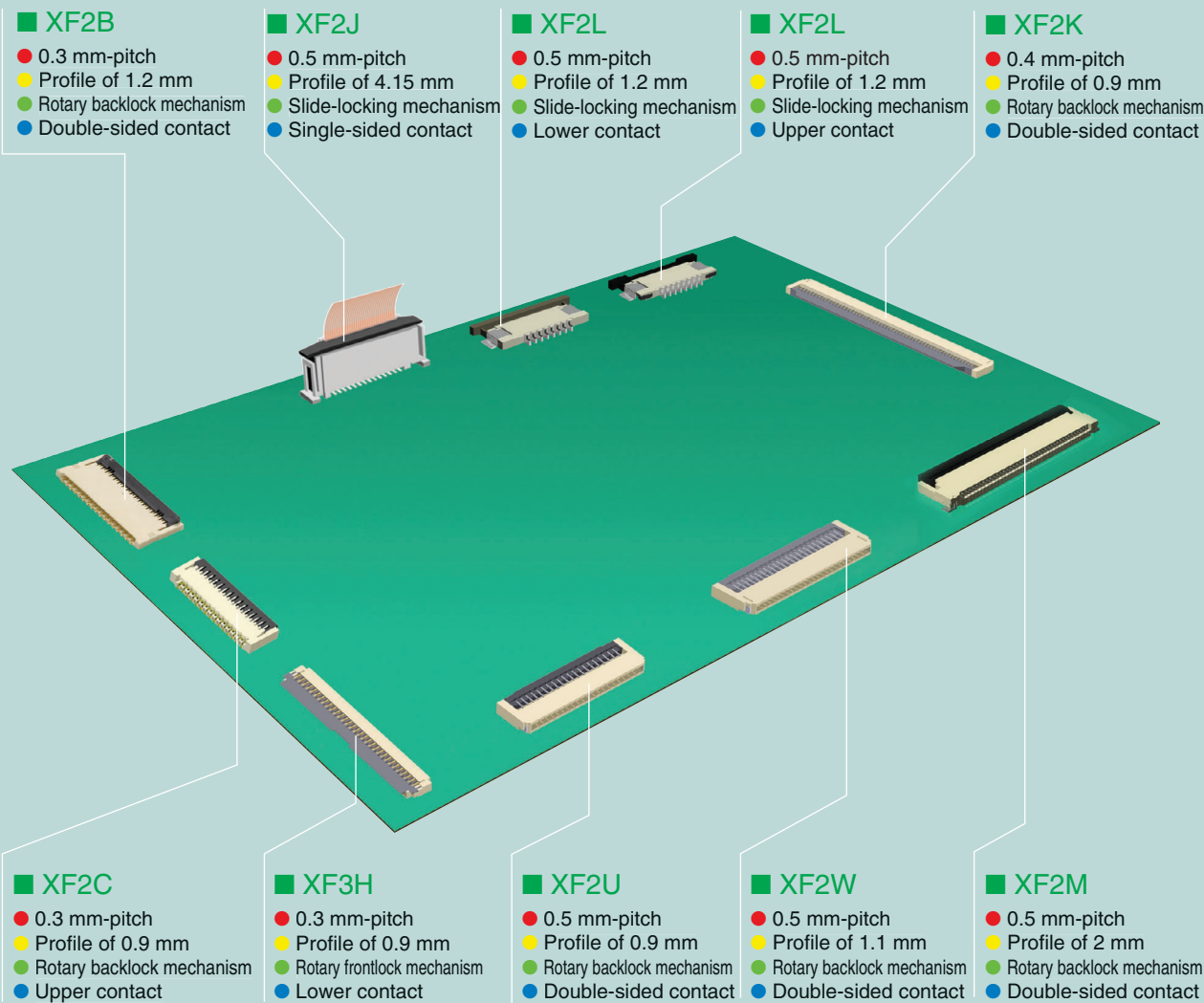

## Applications

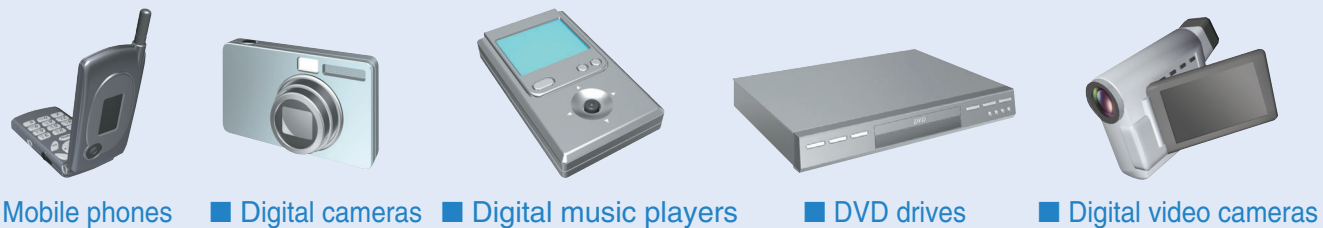

# INDEX

## Product Overview

Model	Lock mechanism	Pitch	On-board profile	Depth	Applicable FPC thickness	Contact type	Page
XF2C	Rotary backlock	0.3 mm	0.9 mm	4.0 mm	0.12 mm	Upper contact	P6
XF2B	Rotary backlock	0.3 mm	1.2 mm	5.5 mm	0.2 mm	Double-sided contact (See note 1.)	P7
XF3H	Rotary frontlock	0.3 mm	0.9 mm	3.2 mm	0.2 mm	Lower contact	P9
XF2K	Rotary backlock	0.4 mm	0.9 mm	3.5 mm	0.2 mm	Double-sided contact	P11
XF2U	Rotary backlock	0.5 mm	0.9 mm	3.5 mm	0.2 mm	Double-sided contact	P12
XF2W	Rotary backlock	0.5 mm	1.1 mm	3.5 mm	0.3 mm	Double-sided contact	P13
XF2M	Rotary backlock	0.5 mm	2.0 mm (See note 2.)	5.9 mm (See note 2.)	0.3 mm	Double-sided contact	P15
XF2L	Slide lock	0.5 mm	1.2 mm	3.5 mm	0.3 mm	Upper/lower contact	P17
XF2J	Slide lock	0.5 mm	4.15 mm	3.4 mm	0.3 mm	Single-sided contact	P19

Note 1: Models with 61 pins have upper contacts.  
 Note 2: Specifications for models with 55 pins and those with 60 pins differ.

## Model Number Legend

Use this legend when determining the product specifications from the model number. Choose from the model numbers listed in this catalog when ordering.

XF       -             -          -   

(1) (2) (3) (4) (5) (6) (7) (8)

- |   |   |  |
|---|---|--|
| (1) Series Classification<br>2B, 2C, 2J, 2K, 2L, 2M, 2U, 2W, 3H   | (5) Applicable FPC Thickness<br>1: 0.3 mm<br>3: 0.2 mm<br>4: 0.12 mm<br>5: 0.15 mm  | (7) Plating<br>A: Au   |
| (2) Number of Signal Contact Pins   | (6) Terminal Arrangement<br>□: Standard<br>1: Staggered arrangement (forward arrangement)<br>2: Staggered arrangement (reverse arrangement) | (8) Special Specification<br>R100: 100 units (small lot)<br><b>Note:</b> Supported only for the XF2M.<br>E: Easy lock type<br>H: For multiple pins |
| (3) Contact Arrangement<br>1: One-row, double-sided contact<br>2: One-row, single-sided contact (including upper contact and top entry)<br>3: One-row, single-sided contact (lower contact)<br>4: Two-row, double-sided contact<br>5: Two-row, single-sided contact | (4) Terminal Shape<br>4: SMT terminals (top entry)<br>5: SMT terminals (side entry)   |  |

# Features of Rotary Backlock Mechanism

# Next-generation Products

## Improvement 1

Rotary slider independent of the FPC socket

- ➔ Slider does not disconnect if the FPC is lifted.
- High reliability--A mounted FPC will not come off if excess force is applied to it.

## Improvement 2

Four-sided FPC housing

- ➔ Construction prevents FPC displacement.
- Mounting reliability is enhanced because the FPC is held in a four-sided housing and is unaffected by the slider operation.

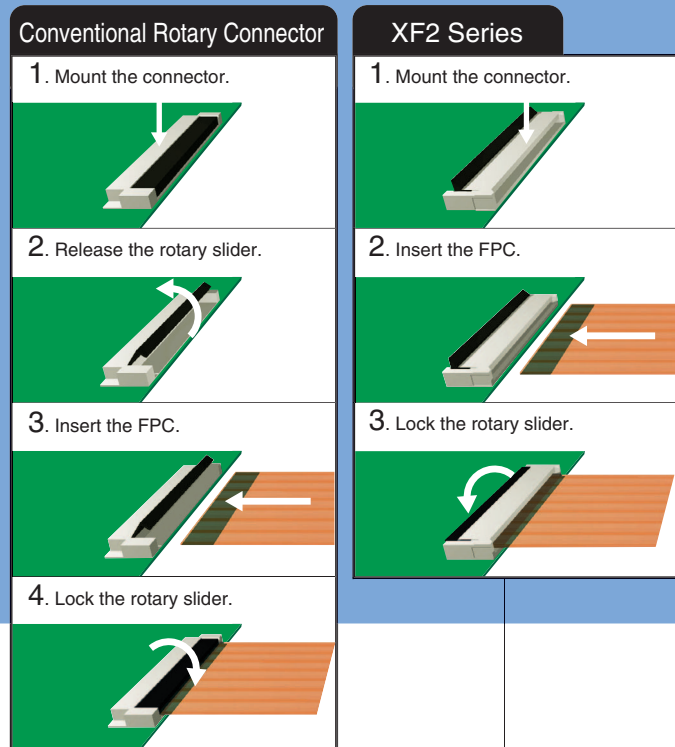
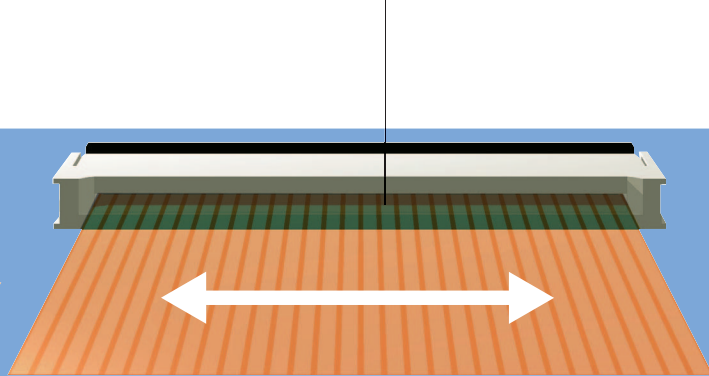
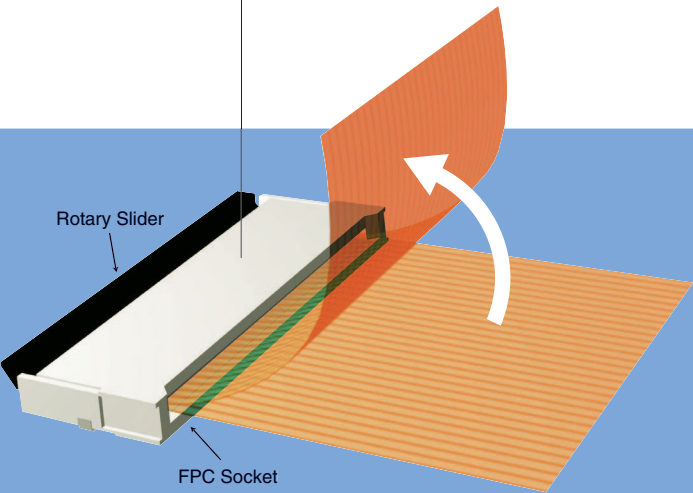

## Improvement 3

Double-sided contact

Note: Except the XF2C and 61-pin XF2B-61.

- ➔ No need to discriminate between the upper and lower FPC contacts.
- Connectors are the same, so it's not necessary to distinguish between the upper and lower contacts when connecting upper and lower PCBs.

## Improvement 4

Delivered with the rotary slider open.

- ➔ Reduces the labor required to mount FPCs.
- Assembly productivity is improved over the conventional rotary locking type because the rotary slider does not need to be released.

OMRON delivers cutting-edge innovative products a step ahead of customer needs. Please look forward to the continuing development of our new products.

## Ultra-slim FPC Connectors

Ultra-low profile with an on-board height of 0.5 mm.

- Ultra-slim construction supports LCR downsizing.
- The rotary front lock ensures operability.
- FPC locking mechanism improves contact reliability.

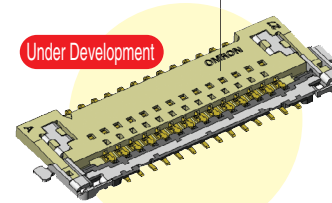

- Greatly Reduced On-board Profile

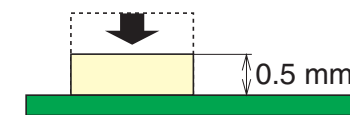

- Contributing to Downsizing of Mobile Devices

Devices can now be downsized more than is possible with conventional connectors.

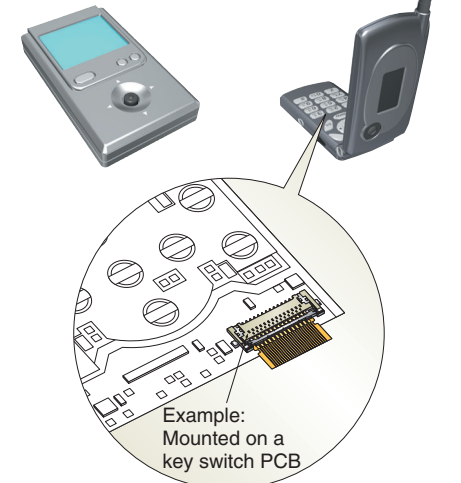

Application Illustration

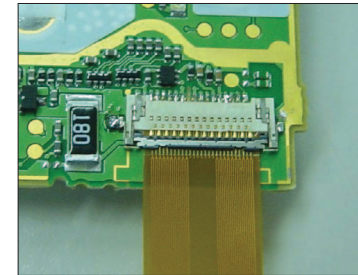

- Connector Specifications (Reference)

Pitch	0.3 mm
On-board profile	0.5 mm
FPC thickness	0.12 mm
Contact orientation	Upper contact
Lock mechanism	Rotary frontlock

## F-to-F Connectors

Connecting FPC to FPC

- No mounting required: Boards can be designed more freely.
- Reliable contact even for open-air wiring.
- FPC temporary locking mechanism improves ease of operation.

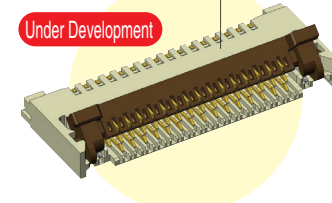

Application Illustration

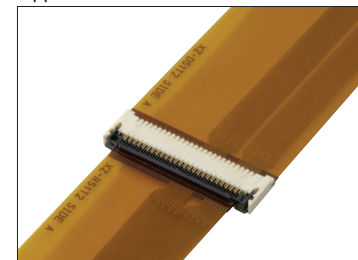

- Device Standardization

F-to-F connectors enable standardization of devices.

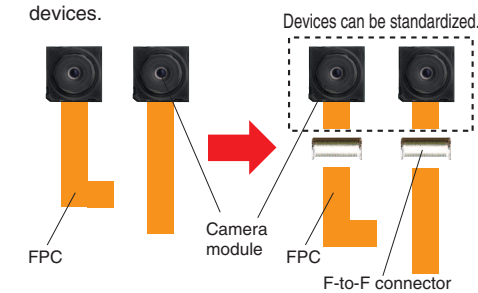

- Effective Use of Space Inside Devices.

F-to-F connectors do not require mounting, so available space can be used.

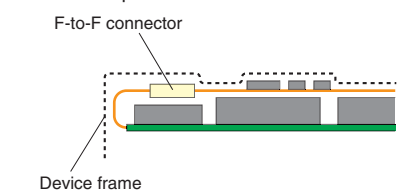

- Increased FPC Board Area Efficiency

F-to-F connectors enable FPCs to be separated for efficient use of PCB area.

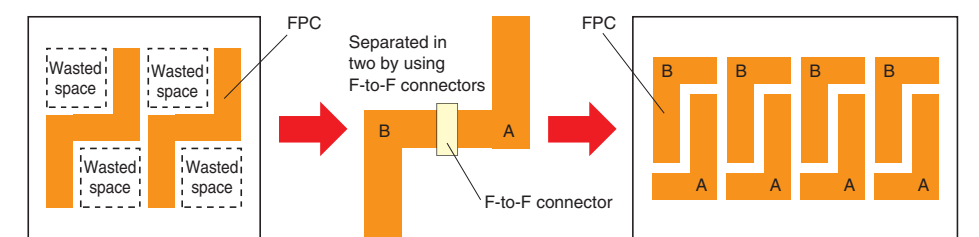

# Features of Rotary Backlock Mechanism

# Next-generation Products

## Improvement 1

Rotary slider independent of the FPC socket

- ➔ Slider does not disconnect if the FPC is lifted.
- High reliability--A mounted FPC will not come off if excess force is applied to it.

## Improvement 2

Four-sided FPC housing

- ➔ Construction prevents FPC displacement.
- Mounting reliability is enhanced because the FPC is held in a four-sided housing and is unaffected by the slider operation.

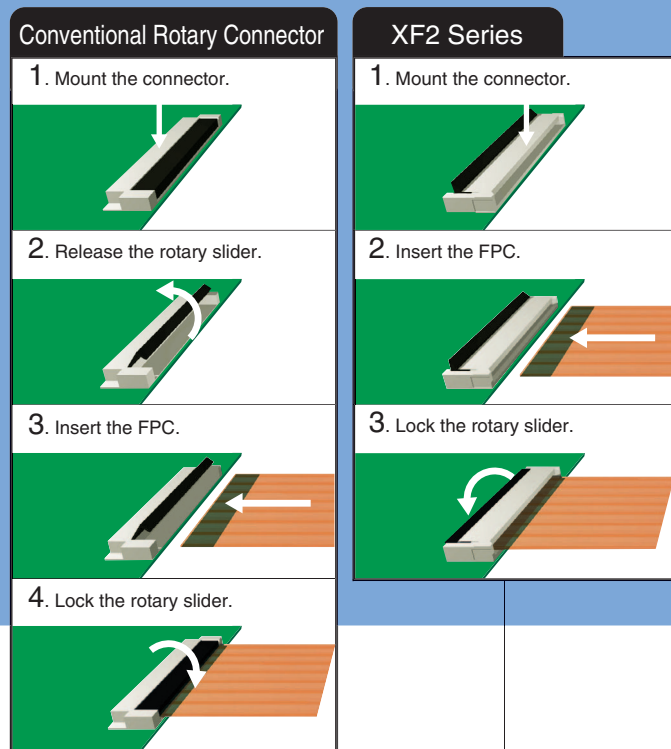
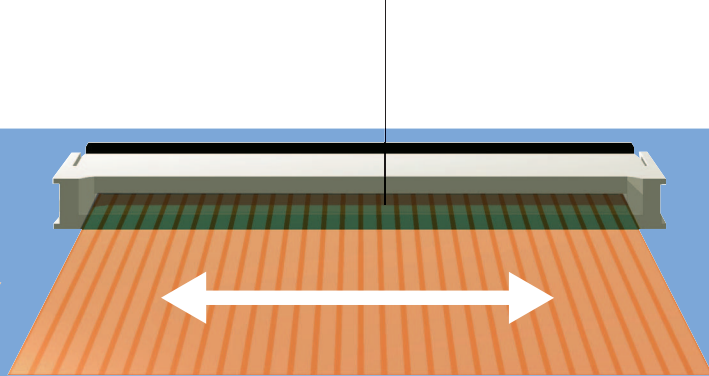
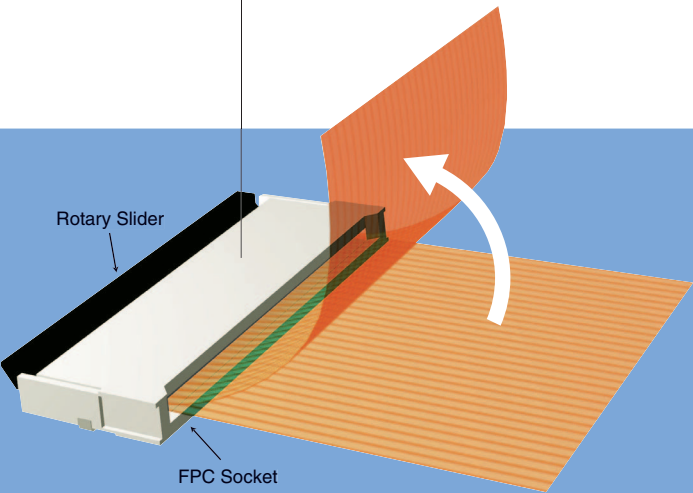

## Improvement 3

Double-sided contact

Note: Except the XF2C and 61-pin XF2B-61.

- ➔ No need to discriminate between the upper and lower FPC contacts.
- Connectors are the same, so it's not necessary to distinguish between the upper and lower contacts when connecting upper and lower PCBs.

## Improvement 4

Delivered with the rotary slider open.

- ➔ Reduces the labor required to mount FPCs.
- Assembly productivity is improved over the conventional rotary locking type because the rotary slider does not need to be released.

OMRON delivers cutting-edge innovative products a step ahead of customer needs. Please look forward to the continuing development of our new products.

## Ultra-slim FPC Connectors

Ultra-low profile with an on-board height of 0.5 mm.

- Ultra-slim construction supports LCR downsizing.
- The rotary front lock ensures operability.
- FPC locking mechanism improves contact reliability.

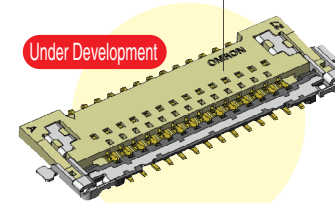

- Greatly Reduced On-board Profile

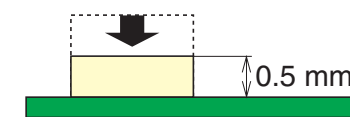

- Contributing to Downsizing of Mobile Devices

Devices can now be downsized more than is possible with conventional connectors.

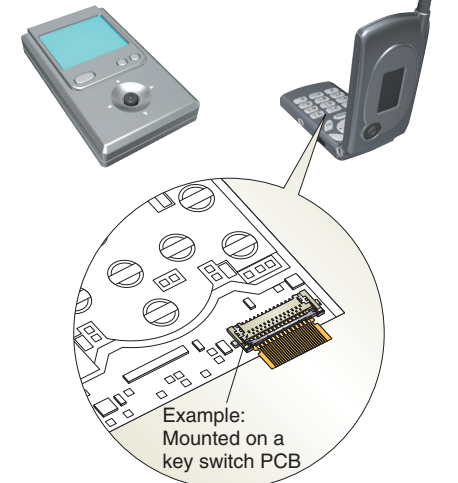

Application Illustration

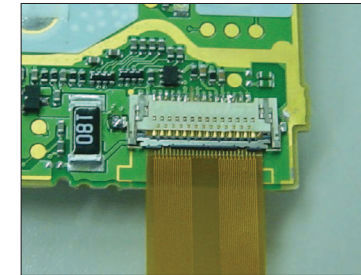

- Connector Specifications (Reference)

Pitch	0.3 mm
On-board profile	0.5 mm
FPC thickness	0.12 mm
Contact orientation	Upper contact
Lock mechanism	Rotary frontlock

## F-to-F Connectors

Connecting FPC to FPC

- No mounting required: Boards can be designed more freely.
- Reliable contact even for open-air wiring.
- FPC temporary locking mechanism improves ease of operation.

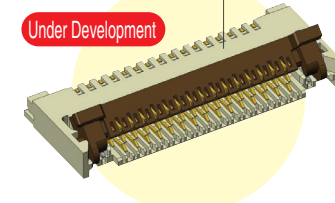

Application Illustration

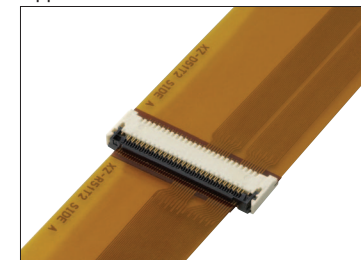

- Device Standardization

F-to-F connectors enable standardization of devices.

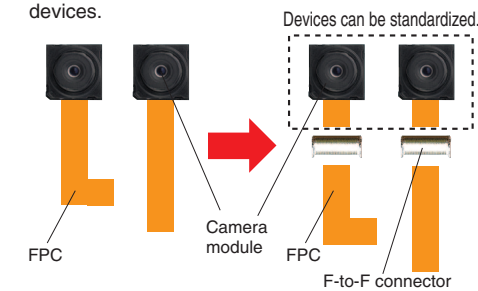

- Effective Use of Space Inside Devices.

F-to-F connectors do not require mounting, so available space can be used.

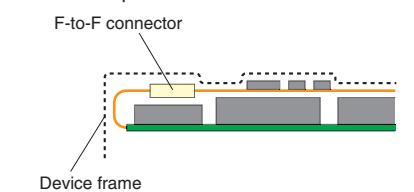

- Increased FPC Board Area Efficiency

F-to-F connectors enable FPCs to be separated for efficient use of PCB area.

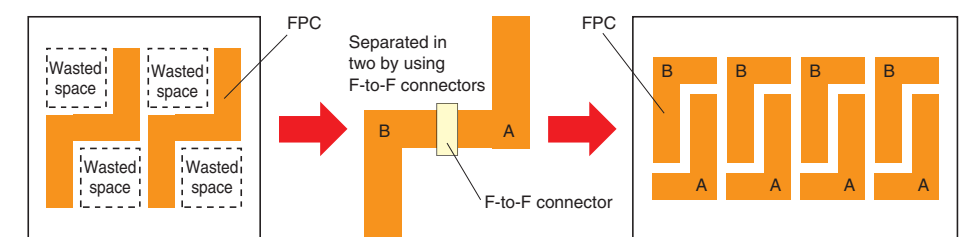

# Rotary Backlock Connector (0.3-mm Pitch, Upper Contact)

# XF2C

## Rotating Backlock Mechanism with 0.3-mm Pitch and Low Profile of 0.9 mm

- Wide molding wall on the rear bottom of the connector allows greater freedom in board design.
- Upper contact model.
- Gold plated with an applicable FPC thickness of 0.12 mm.

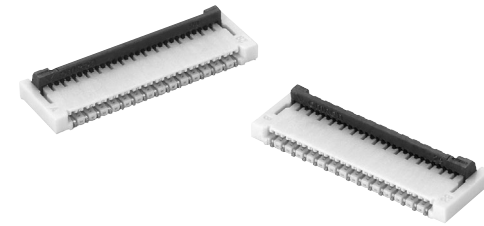

RoHS Compliant

## ■ Ratings and Specifications

Rated current	0.2 A AC/DC
Rated voltage	50 V AC/DC
Contact resistance	80 mΩ max. (at 20 mV max., 100 mA max.)
Insulation resistance	100 MΩ min. (at 250 V DC)
Withstand voltage	250 V AC for 1 min. (leakage current: 1 mA max.)
Insertion tolerance	10 times
Ambient operating temperature	-30 to 85°C (with no icing or condensation)

## ■ Materials and Finish

Housing	LCP resin (UL94V-0)/natural
Slider	LCP resin (UL94V-0)/black
Contacts	Spring copper alloy/nickel substrate (2 μm), gold-plated contacts (0.15 μm)

## ■ Dimensions

XF2C-□□55-41A

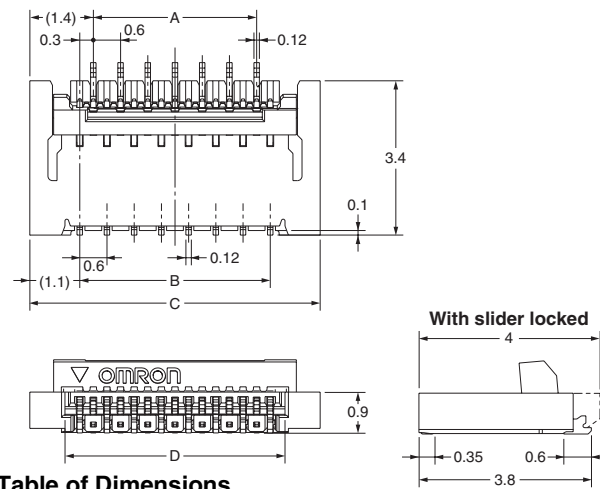
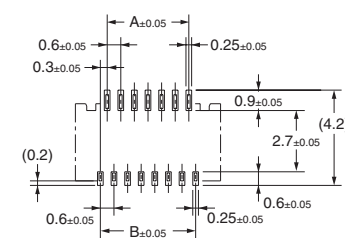

Table of Dimensions

Pins (See note 1.)	Model	A	B	C	D
17	XF2C-1755-41A	4.2	4.8	7.0	5.5
21	XF2C-2155-41A	5.4	6.0	8.2	6.7
25	XF2C-2555-41A	6.6	7.2	9.4	7.9
29	XF2C-2955-41A	7.8	8.4	10.6	9.1
35	XF2C-3555-41A	9.6	10.2	12.4	10.9
39	XF2C-3955-41A	10.8	11.4	13.6	12.1
(45)	XF2C-4555-41A	12.6	13.2	15.4	13.9
51	XF2C-5155-41A	14.4	15.0	17.2	15.7

PCB Mating Dimensions (Top View)



Applicable FPC Dimensions

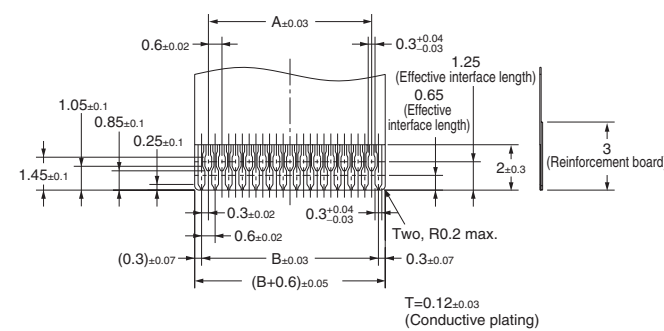

## ■ Ordering Information

Pins (See note 1.)	Model	Quantity per reel (See note 2.)
17	XF2C-1755-41A	2,000
21	XF2C-2155-41A	
25	XF2C-2555-41A	
29	XF2C-2955-41A	
35	XF2C-3555-41A	
39	XF2C-3955-41A	
(45)	XF2C-4555-41A	
51	XF2C-5155-41A	

- Note: 1.** The models with the number of pins in parentheses will be released in November 2006. Consult your OMRON representative for inquiries related to pin number specifications.
- 2.** Order an integer multiple of the quantity per reel.

### Pin Number Specifications

Refer to the following website for the latest information.  
<http://www.omron.co.jp/ecb/>

# Rotary Backlock Connector (0.3-mm Pitch, Double-sided Contact)

# XF2B

## Rotary Backlock Mechanism with 0.3-mm Pitch

- Wide molding wall on the rear bottom of the connector allows greater freedom in board design.
- Double-sided contact reduces the number of parts.
- Gold plated with an applicable FPC thickness of 0.2 mm.

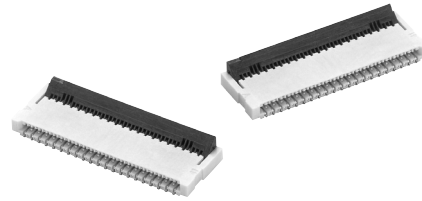

RoHS Compliant

## ■ Ratings and Specifications

<b>Rated current</b>	0.2 A AC/DC
<b>Rated voltage</b>	50 V AC/DC
<b>Contact resistance</b>	50 mΩ max. (at 20 mV max., 100 mA max.)
<b>Insulation resistance</b>	100 MΩ min. (at 250 V DC)
<b>Withstand voltage</b>	250 V AC for 1 min. (leakage current: 1 mA max.)
<b>Insertion tolerance</b>	20 times
<b>Ambient operating temperature</b>	-30 to 85°C (with no icing or condensation)

## ■ Materials and Finish

<b>Housing</b>	LCP resin (UL94V-0)/natural
<b>Slider</b>	LCP resin (UL94V-0)/black
<b>Contacts</b>	Spring copper alloy/nickel substrate (2 μm), gold-plated contacts (0.15 μm)

## ■ Dimensions

XF2B-□□45-31A

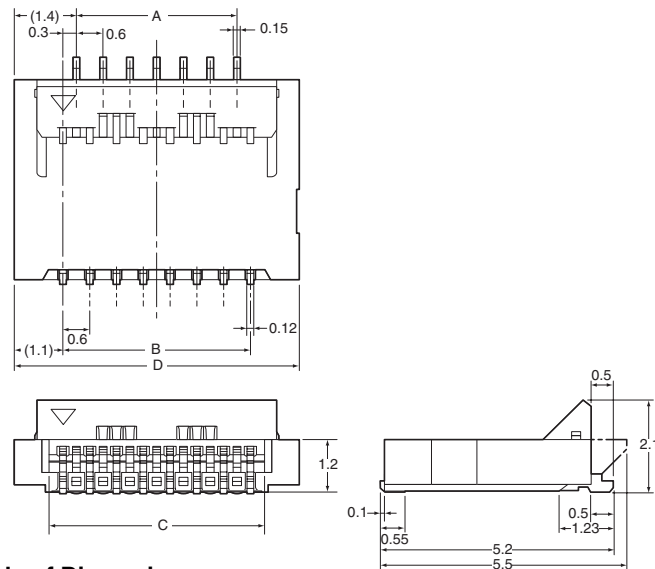

PCB Mating Dimensions (Top View)

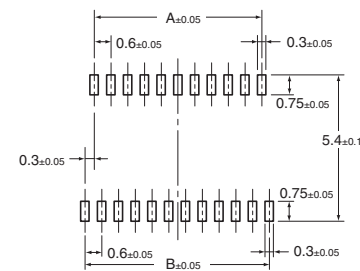

Applicable FPC Dimensions

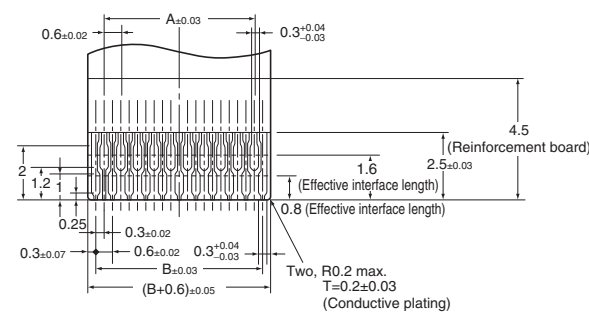

Table of Dimensions

Pins (See note 1.)	Model	A	B	C	D
17	XF2B-1745-31A	4.2	4.8	5.5	7.0
21	XF2B-2145-31A	5.4	6.0	6.7	8.2
23	XF2B-2345-31A	6.0	6.6	7.3	8.8
25	XF2B-2545-31A	6.6	7.2	7.9	9.4
27	XF2B-2745-31A	7.2	7.8	8.5	10.0
31	XF2B-3145-31A	8.4	9.0	9.7	11.2
33	XF2B-3345-31A	9.0	9.6	10.3	11.8
35	XF2B-3545-31A	9.6	10.2	10.9	12.4
39	XF2B-3945-31A	10.8	11.4	12.1	13.6
41	XF2B-4145-31A	11.4	12.0	12.7	14.2
45	XF2B-4545-31A	12.6	13.2	13.9	15.4
51	XF2B-5145-31A	14.4	15.0	15.7	17.2
61	XF2B-6155-31A	17.4	18.0	18.7	20.2

## ■ Ordering Information

Pins (See note 1.)	Model	Pins (See note 1.)	Model	Quantity per reel (See note 2.)
17	XF2B-1745-31A	35	XF2B-3545-31A	1,500
21	XF2B-2145-31A	39	XF2B-3945-31A	
23	XF2B-2345-31A	41	XF2B-4145-31A	
25	XF2B-2545-31A	45	XF2B-4545-31A	
27	XF2B-2745-31A	51	XF2B-5145-31A	
31	XF2B-3145-31A	61	XF2B-6155-31A (See note 3.)	
33	XF2B-3345-31A	---	---	

**Note:** 1. Consult your OMRON representative for inquiries related to pin number specifications.

2. Order an integer multiple of the quantity per reel.

3. Upper contact.

### Pin Number Specifications

Refer to the following website for the latest information. <http://www.omron.co.jp/ecb/>



# Rotary Frontlock Connector (0.3-mm Pitch, Lower Contact)

# XF3H

## Front-lock Mechanism with a Depth of 3.2 mm and Low Profile of 0.9 mm

- Ultra-slim connector with a depth of 3.2 mm.
- Wide molding wall on the rear bottom of the connector allows greater freedom in board design.
- Slider open locking mechanism makes work efficient.
- Gold plated with an applicable FPC thickness of 0.2 mm.

RoHS Compliant

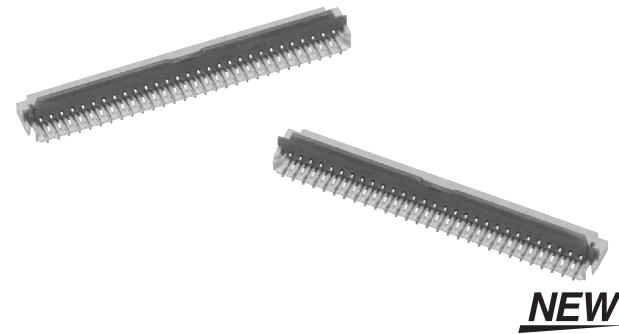

## ■ Ratings and Specifications

Rated current	0.2 A AC/DC
Rated voltage	50 V AC/DC
Contact resistance	80 mΩ max. (at 20 mV max., 100 mA max.)
Insulation resistance	100 MΩ min. (at 250 V DC)
Withstand voltage	250 V AC for 1 min. (leakage current: 1 mA max.)
Insertion tolerance	10 times
Ambient operating temperature	-30 to 85°C (with no icing or condensation)

## ■ Materials and Finish

Housing	LCP resin (UL94V-0)/natural
Slider	LCP resin (UL94V-0)/brown
Contacts	Spring copper alloy/nickel substrate (2 μm), gold-plated contacts (0.15 μm)

## ■ Dimensions

XF3H-□□55-31A

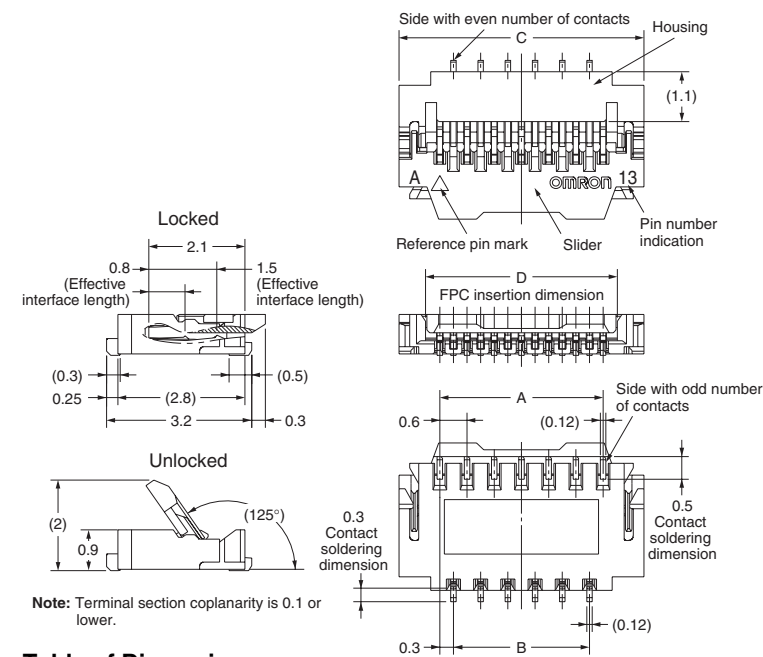
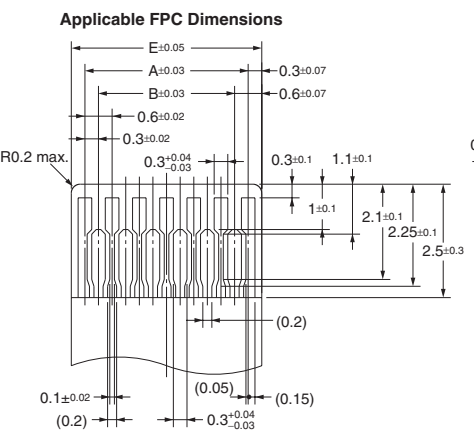
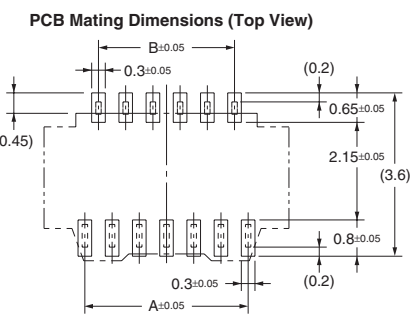

Table of Dimensions

Pins (See note 1.)	Model	A	B	C	D	E
25	XF3H-2555-31A	7.2	6.6	9.0	7.83	7.8
35	XF3H-3555-31A	10.2	9.6	12.0	10.83	10.8
39	XF3H-3955-31A	11.4	10.8	13.2	12.03	12.0
57	XF3H-5755-31A	16.8	16.2	18.6	17.43	17.4



**■ Ordering Information**

Pins (See note 1.)	Model	Quantity per reel (See note 2.)
25	XF3H-2555-31A	3,000
35	XF3H-3555-31A	
39	XF3H-3955-31A	
57	XF3H-5755-31A	

**Note:** 1. Consult your OMRON representative for inquiries related to pin number specifications.

2. Order an integer multiple of the quantity per reel.

**Pin Number Specifications**

Refer to the following website for the latest information.

<http://www.omron.co.jp/ecb/>

# Rotary Backlock Connector (0.4-mm Pitch, Double-sided Contact)

# XF2K

## Rotary Backlock Mechanism with a Depth of 0.4 mm and Low Profile of 0.9 mm

- Long slider makes it easier to lock and unlock the connector.
- Double-sided contacts reduce the number of parts.
- Gold plated with an applicable FPC thickness of 0.2 mm.

RoHS Compliant



**NEW**

## ■ Ratings and Specifications

Rated current	0.2 A AC/DC
Rated voltage	50 V AC/DC
Contact resistance	60 mΩ max. (at 20 mV max., 100 mA max.)
Insulation resistance	100 MΩ min. (at 250 V DC)
Withstand voltage	250 V AC for 1 min (leakage current: 1 mA max.)
Insertion tolerance	20 times
Ambient operating temperature	-30 to 85°C (with no icing or condensation)

## ■ Materials and Finish

Housing	LCP resin (UL94V-0)/natural
Slider	LCP resin (UL94V-0)/brown
Contacts	Spring copper alloy/nickel substrate (2 μm), gold-plated contacts (0.15 μm)
Hold-down	Spring copper alloy/fused-tin plating (2 μm)

## ■ Dimensions

XF2K-□□15-3AE

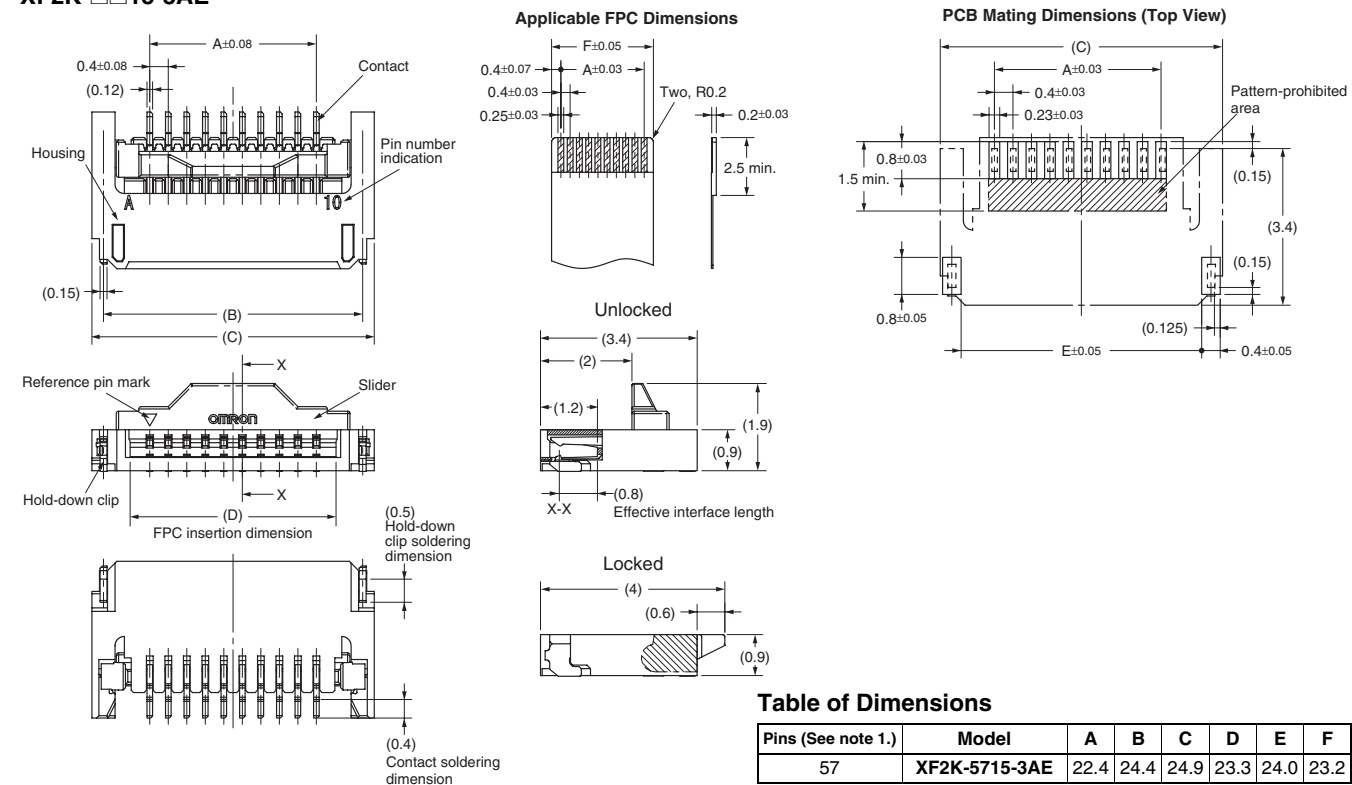

## ■ Ordering Information

Pins (See note 1.)	Model	Quantity per reel (See note 2.)
57	XF2K-5715-3AE	2,000

- Note: 1.** Consult your OMRON representative for inquiries related to pin number specifications.  
**2.** Order an integer multiple of the quantity per reel.

### Pin Number Specifications

Refer to the following website for the latest information.  
<http://www.omron.co.jp/ecb/>

# Rotary Backlock Connector (0.5-mm Pitch, Double-sided Contact)

# XF2U

## Rotary Backlock Mechanism with a Depth of 3.5 mm and Low Profile of 0.9 mm

- Ultra-slim connector with a depth of 3.5 mm.
- Double-sided contacts reduce the number of parts.
- Wide molding wall on the rear bottom of the connector allows greater freedom in board design.
- Gold plated with an applicable FPC thickness of 0.2 mm.

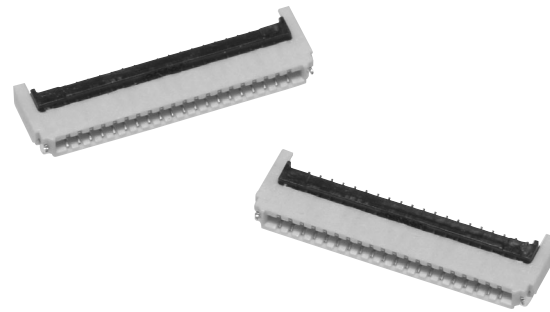

RoHS Compliant

## ■ Ratings and Specifications

Rated current	0.5 A AC/DC
Rated voltage	50 V AC/DC
Contact resistance	60 mΩ max. (at 20 mV max., 100 mA max.)
Insulation resistance	100 MΩ min. (at 250 V DC)
Withstand voltage	250 V AC for 1 min (leakage current: 1 mA max.)
Insertion tolerance	20 times
Ambient operating temperature	-30 to 85°C (with no icing or condensation)

## ■ Materials and Finish

Housing	LCP resin (UL94V-0)/natural
Slider	LCP resin (UL94V-0)/black
Contacts	Spring copper alloy/nickel substrate (2 μm), gold-plated contacts (0.15 μm)
Hold-down	Spring copper alloy/fused-tin plating (2 μm)

## ■ Dimensions

XF2U-□□15-3A

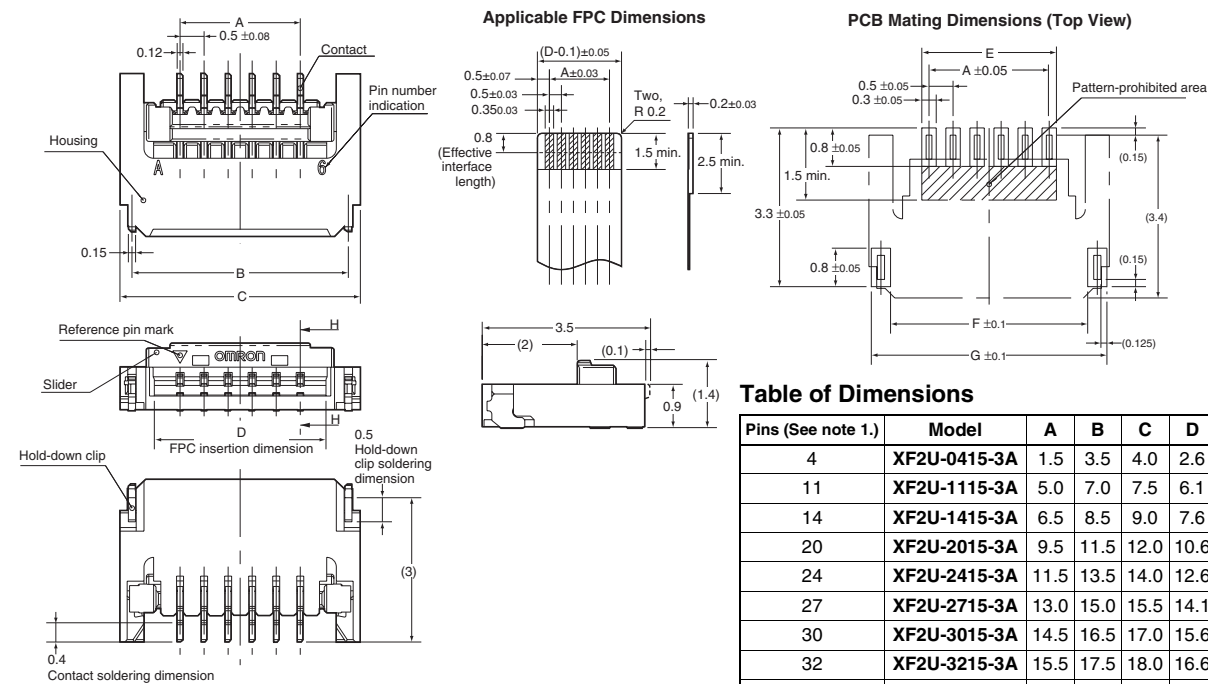

Table of Dimensions

Pins (See note 1.)	Model	A	B	C	D	E	F	G
4	XF2U-0415-3A	1.5	3.5	4.0	2.6	1.8	3.1	3.9
11	XF2U-1115-3A	5.0	7.0	7.5	6.1	5.3	6.6	7.4
14	XF2U-1415-3A	6.5	8.5	9.0	7.6	6.8	8.1	8.9
20	XF2U-2015-3A	9.5	11.5	12.0	10.6	9.8	11.1	11.9
24	XF2U-2415-3A	11.5	13.5	14.0	12.6	11.8	13.1	13.9
27	XF2U-2715-3A	13.0	15.0	15.5	14.1	13.3	14.6	15.4
30	XF2U-3015-3A	14.5	16.5	17.0	15.6	14.8	16.1	16.9
32	XF2U-3215-3A	15.5	17.5	18.0	16.6	15.8	17.1	17.9
40	XF2U-4015-3A	19.5	21.5	22.0	20.6	19.8	21.1	21.9

## ■ Ordering Information

Pins (See note 1.)	Model	Quantity per reel (See note 2.)
4	XF2U-0415-3A	3,000
11	XF2U-1115-3A	
14	XF2U-1415-3A	
20	XF2U-2015-3A	
24	XF2U-2415-3A	
27	XF2U-2715-3A	
30	XF2U-3015-3A	
32	XF2U-3215-3A	
40	XF2U-4015-3A	

- Note: 1.** Consult your OMRON representative for inquiries related to pin number specifications.  
**2.** Order an integer multiple of the quantity per reel.

### Pin Number Specifications

Refer to the following website for the latest information.  
<http://www.omron.co.jp/ecb/>

# Rotary Backlock Connector (0.5-mm Pitch, Double-sided Contact)

# XF2W

## Rotary Backlock Mechanism with 0.5-mm Pitch and Low Profile of 1.1 mm

- Two models available: Ultra-slim connector with a depth of 3.5 mm and easy-operation connector with long slider.
- Double-sided contacts reduce the number of parts.
- Wide molding wall on the rear bottom of the connector allows greater freedom in board design.
- Applicable FPC thickness of 0.3 mm.



**NEW**

RoHS Compliant

## ■ Ratings and Specifications

XF2W-□□15-1A/1AE

Rated current	0.5 A AC/DC
Rated voltage	50 V AC/DC
Contact resistance	60 mΩ max. (at 20 mV max., 100 mA max.)
Insulation resistance	100 MΩ min. (at 250 V DC)
Withstand voltage	250 V AC for 1 min (leakage current: 1 mA max.)
Insertion tolerance	20 times
Ambient operating temperature	-30 to 85°C (with no icing or condensation)

## ■ Materials and Finish

XF2W-□□15-1A/1AE

Housing	LCP resin (UL94V-0)/natural
Slider	LCP resin (UL94V-0)/brown
Contacts	Spring copper alloy/nickel substrate (2 μm), gold-plated contacts (0.15 μm)
Hold-down	Spring copper alloy/fused-tin plating (2 μm)

## ■ Dimensions

XF2W-□□15-1□

XF2W-□□15-1□E

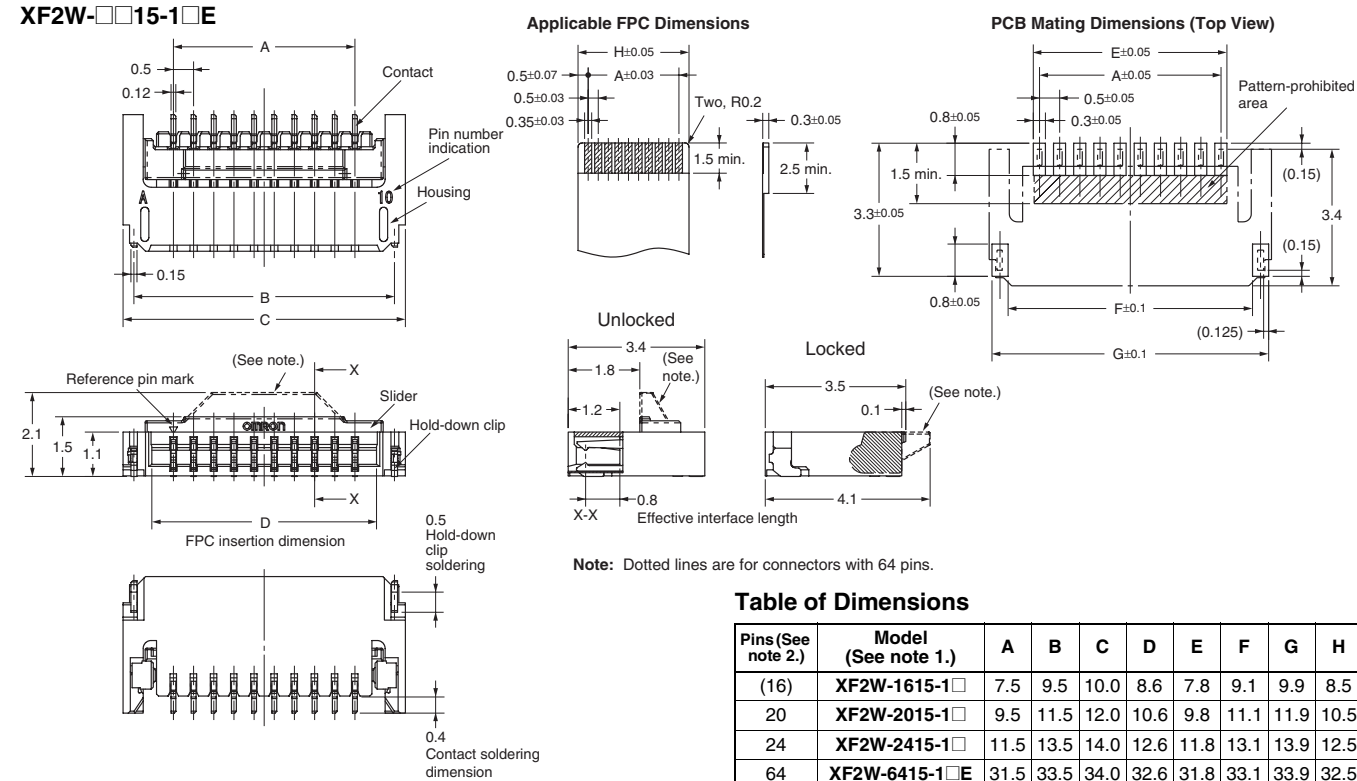

## ■ Ordering Information

Pins (See note 2.)	Model (See note 1.)	Quantity per reel (See note 3.)
(16)	XF2W-1615-1□	2,000
20	XF2W-2015-1□	
24	XF2W-2415-1□	
64	XF2W-6415-1□E	

- Note: 1.** The symbol in the box at the end of the model number indicates the type of plating.  
A: Gold-plated (RoHS compliant)  
The end of the model number indicates the slider specification.  
None: Standard, E: Multiple pins
- 2** The models with the number of pins in parentheses will be released in November 2006. Consult your OMRON representative for inquiries related to pin number specifications for the models under development and of other pin numbers not listed.
- 3.** Order an integer multiple of the quantity per reel.

### Pin Number Specifications

Refer to the following website for the latest information. <http://www.omron.co.jp/ecb/>

# Rotary Backlock Connector (0.5-mm Pitch, Double-sided Contact)

# XF2M

Rotary Lock Achieves High Reliability and Superior Work Efficiency.

- Double-sided contact reduces the number of parts.
- Applicable FPC thickness of 0.3 mm.

RoHS Compliant

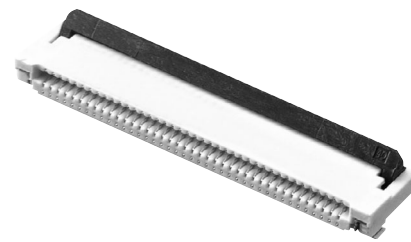

## ■ Ratings and Specifications

XF2M-□□15-1A/1AH

Rated current	0.5 A AC/DC
Rated voltage	50 V AC/DC
Contact resistance	50 mΩ max. (at 20 mV max., 100 mA max.)
Insulation resistance	100 MΩ min. (at 250 V DC)
Withstand voltage	250 V AC for 1 min. (leakage current: 1 mA max.)
Insertion tolerance	20 times
Ambient operating temperature	-30 to 85°C (with no icing or condensation)

## ■ Materials and Finish

XF2M-□□15-1A/1AH

Housing	LCP resin (UL94V-0)/natural
Slider	LCP resin (UL94V-0)/black
Contacts	Spring copper alloy/nickel substrate (2 μm), gold-plated contacts (0.15 μm)
Hold-down	Spring copper alloy/fused-tin plating (1.5 μm)

## ■ Dimensions

XF2M-□□15-1□

XF2M-□□15-1□H

Table of Dimensions

Pins (See note 2.)	Model (See note 1.)	A	B	C	D	E	F	G
10	XF2M-1015-1□	4.5	5.6	8.5	9.1	7.1	6.1	9.5
12	XF2M-1215-1□	5.5	6.6	9.5	10.1	8.1	7.1	10.5
14	XF2M-1415-1□	6.5	7.6	10.5	11.1	9.1	8.1	11.5
18	XF2M-1815-1□	8.5	9.6	12.5	13.1	11.1	10.1	13.5
20	XF2M-2015-1□	9.5	10.6	13.5	14.1	12.1	11.1	14.5
22	XF2M-2215-1□	10.5	11.6	14.5	15.1	13.1	12.1	15.5
24	XF2M-2415-1□	11.5	12.6	15.5	16.1	14.1	13.1	16.5
26	XF2M-2615-1□	12.5	13.6	16.5	17.1	15.1	14.1	17.5
30	XF2M-3015-1□	14.5	15.6	18.5	19.1	17.1	16.1	19.5
32	XF2M-3215-1□	15.5	16.6	19.5	20.1	18.1	17.1	20.5
33	XF2M-3315-1□	16.0	17.1	20.0	20.6	18.6	17.6	21.0
34	XF2M-3415-1□	16.5	17.6	20.5	21.1	19.1	18.1	21.5
35	XF2M-3515-1□	17.0	18.1	21.0	21.6	19.6	18.6	22.0
36	XF2M-3615-1□	17.5	18.6	21.5	22.1	20.1	19.1	22.5
38	XF2M-3815-1□	18.5	19.6	22.5	23.1	21.1	20.1	23.5
40	XF2M-4015-1□	19.5	20.6	23.5	24.1	22.1	21.1	24.5
42	XF2M-4215-1□	20.5	21.6	24.5	25.1	23.1	22.1	25.5
45	XF2M-4515-1□	22.0	23.1	26.0	26.6	24.6	23.6	27.0
50	XF2M-5015-1□	24.5	25.6	28.5	29.1	27.1	26.1	29.5
(55)	XF2M-5515-1□H	27.0	28.1	31.0	31.6	29.6	28.6	32.0
(60)	XF2M-6015-1□H	29.5	30.6	33.5	34.1	32.1	31.1	34.5

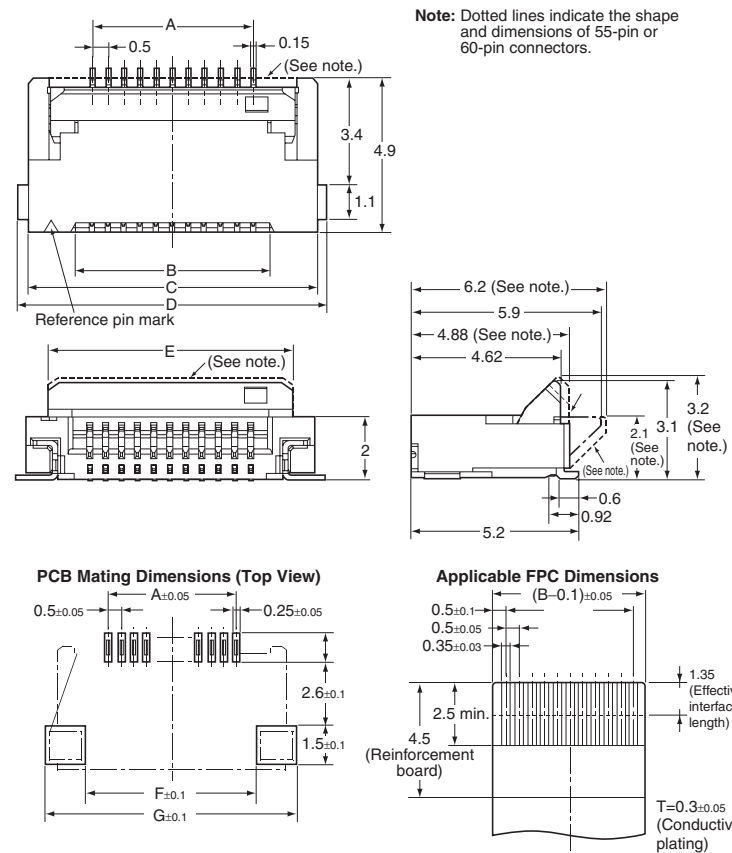

## ■ Ordering Information

Pins (See note 2.)	Model (See note 1.)	Pins (See note 2.)	Model (See note 1.)	Pins (See note 2.)	Model (See note 1.)	Quantity per reel (See note 3.)
10	XF2M-1015-1□	26	XF2M-2615-1□	38	XF2M-3815-1□	1,500
12	XF2M-1215-1□	30	XF2M-3015-1□	40	XF2M-4015-1□	
14	XF2M-1415-1□	32	XF2M-3215-1□	42	XF2M-4215-1□	
18	XF2M-1815-1□	33	XF2M-3315-1□	45	XF2M-4515-1□	
20	XF2M-2015-1□	34	XF2M-3415-1□	50	XF2M-5015-1□	
22	XF2M-2215-1□	35	XF2M-3515-1□	(55)	XF2M-5515-1□H	
24	XF2M-2415-1□	36	XF2M-3615-1□	(60)	XF2M-6015-1□H	

**Note: 1.** The symbol in the box at the end of the model number indicates the type of plating.

A: Gold-plated (RoHS compliant).

The end of the model number indicates the slider specification.

None: Standard, H: For multiple pins

**2.** The models with the number of pins in parentheses will be released in November 2006. Consult your OMRON representative for inquiries related to pin number specifications for the models under development and of other pin numbers not listed above.

**3.** Order an integer multiple of the quantity per reel. Small-lot orders (for 100 units) can also be accepted.

When ordering, specify model numbers ending with R-100 for 100 units.

**4.** Consult your OMRON representative for inquiries about lead-free tin solder.

**5.** Solder plating (specified by -1L at the end of the model number) ended production March 2006.

### Pin Number Specifications

Refer to the following website for the latest information. <http://www.omron.co.jp/ecb/>



# ZIF Slide-locking Connector (0.5-mm Pitch)

# XF2L

## Greater Freedom in Board Design with a Bottom Wall and the Smallest On-board Area in the Industry

- Smallest on-board area and volume in the industry.
- Low on-board profile of only 1.2 mm.
- Highest board design surface efficiency in the industry with a bottom wall preventing terminal exposure.
- Construction with secure slider locking mechanism.
- Applicable FPC thickness of 0.3 mm.



RoHS Compliant

## ■ Ratings and Specifications

XF2L-□□□5-1A

Rated current	0.5 A AC/DC
Rated voltage	50 V AC/DC
Contact resistance	30 mΩ max. (at 20 mV DC max., 100 mA max.)
Insulation resistance	100 MΩ min. (at 250 V DC)
Withstand voltage	250V AC for 1 min. (leakage current: 1 mA max.)
Insertion tolerance	20 times
Ambient operating temperature	-30 to 85°C (with no icing or condensation)

## ■ Materials and Finish

XF2L-□□□5-1A

Model	XF2L (Upper-contact Models)	XF2L (Lower-contact Models)
Housing	LCP resin (UL94V-0)/natural	
Slider	LCP resin (UL94V-0)/black	LCP resin (UL94V-0)/brown
Contacts	Spring copper alloy/nickel substrate (2 μm), gold-plated contacts (0.15 μm)	
Hold-down	Spring copper alloy/fused-tin plating (1.5 μm)	

## ■ Dimensions

XF2L-□□□5-1□

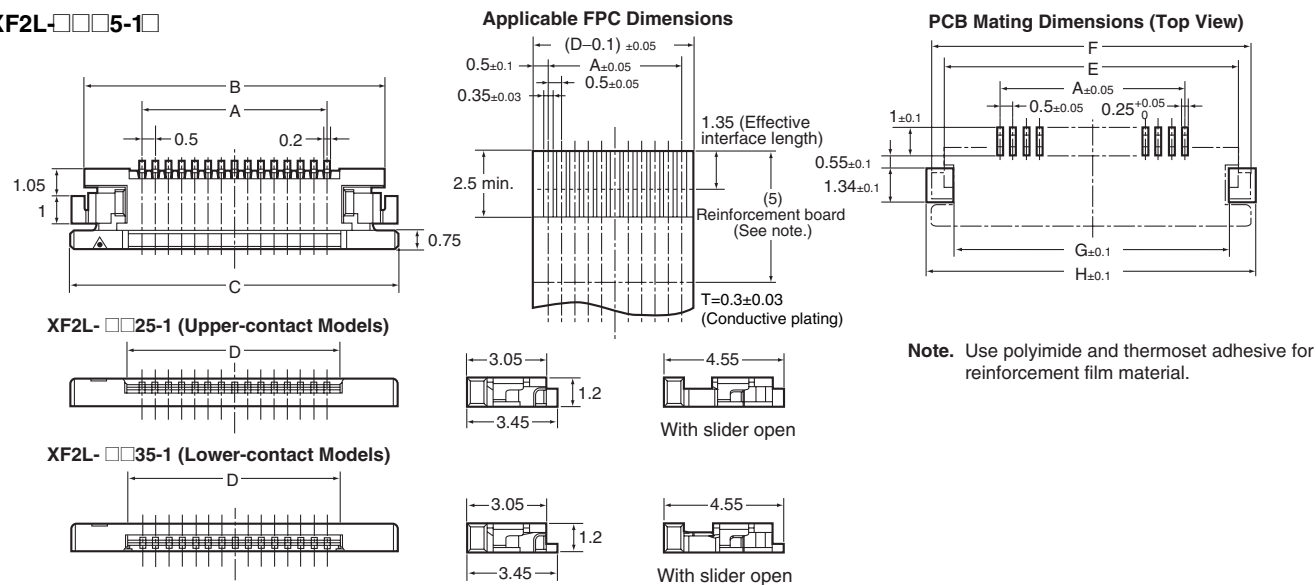

### Table of Dimensions

#### Upper-contact Models

Pins (See note 2.)	Model (See note 1.)	A	B	C	D	E	F	G	H
4	XF2L-0425-1□	1.5	5.9	6.9	2.6	5.88	6.88	5.28	7.28
6	XF2L-0625-1□	2.5	6.9	7.9	3.6	6.88	7.88	6.28	8.28
7	XF2L-0725-1□	3.0	7.4	8.4	4.1	7.38	8.38	6.78	8.78
8	XF2L-0825-1□	3.5	7.9	8.9	4.6	7.88	8.88	7.28	9.28
9	XF2L-0925-1□	4.0	8.4	9.4	5.1	8.38	9.38	7.78	9.78
10	XF2L-1025-1□	4.5	8.9	9.9	5.6	8.88	9.88	8.28	10.28
12	XF2L-1225-1□	5.5	9.9	10.9	6.6	9.88	10.88	9.28	11.28
13	XF2L-1325-1□	6.0	10.4	11.4	7.1	10.38	11.38	9.78	11.78
18	XF2L-1825-1□	8.5	12.9	13.9	9.6	12.88	13.88	12.28	14.28
21	XF2L-2125-1□	10.0	14.4	15.4	11.1	14.38	15.38	13.78	15.78
26	XF2L-2625-1□	12.5	16.9	17.9	13.6	16.88	17.88	16.28	18.28
30	XF2L-3025-1□	14.5	18.9	19.9	15.6	18.88	19.88	18.28	20.28

#### Lower-contact Models

Pins (See note 2.)	Model (See note 1.)	A	B	C	D	E	F	G	H
5	XF2L-0535-1□	2.0	6.4	7.4	3.1	6.38	7.38	5.78	7.78
6	XF2L-0635-1□	2.5	6.9	7.9	3.6	6.88	7.88	6.28	8.28
7	XF2L-0735-1□	3.0	7.4	8.4	4.1	7.38	8.38	6.78	8.78
8	XF2L-0835-1□	3.5	7.9	8.9	4.6	7.88	8.88	7.28	9.28
10	XF2L-1035-1□	4.5	8.9	9.9	5.6	8.88	9.88	8.28	10.28
12	XF2L-1235-1□	5.5	9.9	10.9	6.6	9.88	10.88	9.28	11.28
13	XF2L-1335-1□	6.0	10.4	11.4	7.1	10.38	11.38	9.78	11.78
15	XF2L-1535-1□	7.0	11.4	12.4	8.1	11.38	12.38	10.78	12.78
18	XF2L-1835-1□	8.5	12.9	13.9	9.6	12.88	13.88	12.28	14.28
19	XF2L-1935-1□	9.0	13.4	14.4	10.1	13.38	14.38	12.78	14.78
20	XF2L-2035-1□	9.5	13.9	14.9	10.6	13.88	14.88	13.28	15.28
22	XF2L-2235-1□	10.5	14.9	15.9	11.6	14.88	15.88	14.28	16.28
24	XF2L-2435-1□	11.5	15.9	16.9	12.6	15.88	16.88	15.28	17.28
30	XF2L-3035-1□	14.5	18.9	19.9	15.6	18.88	19.88	18.28	20.28

## ■ Ordering Information

Pins (See note 2.)	Type	Model (See note 1.)	Pins (See note 2.)	Type	Model (See note 1.)	Pins (See note 2.)	Type	Model (See note 1.)	Quantity per reel (See note 3.)
4	Upper-contact	XF2L-0425-1□	10	Upper-contact	XF2L-1025-1□	19	Lower-contact	XF2L-1935-1□	3,000
5	Lower-contact	XF2L-0535-1□		Lower-contact	XF2L-1035-1□	20	Lower-contact	XF2L-2035-1□	
6	Upper-contact	XF2L-0625-1□	12	Upper-contact	XF2L-1225-1□	21	Upper-contact	XF2L-2125-1□	
	Lower-contact	XF2L-0635-1□		Lower-contact	XF2L-1235-1□	22	Lower-contact	XF2L-2235-1□	
7	Upper-contact	XF2L-0725-1□	13	Upper-contact	XF2L-1325-1□	24	Lower-contact	XF2L-2435-1□	
	Lower-contact	XF2L-0735-1□		Lower-contact	XF2L-1335-1□	26	Upper-contact	XF2L-2625-1□	
8	Upper-contact	XF2L-0825-1□	15	Lower-contact	XF2L-1535-1□	30	Upper-contact	XF2L-3025-1□	
	Lower-contact	XF2L-0835-1□		Upper-contact	XF2L-1825-1□		Lower-contact	XF2L-3035-1□	
9	Upper-contact	XF2L-0925-1□	18	Lower-contact	XF2L-1835-1□	---	---	---	

**Note: 1.** The symbol in the box at the end of the model number indicates the type of plating.

A: Gold-plated (RoHS compliant).

**2.** Consult your OMRON representative for inquiries related to pin number specifications.

**3.** Order an integer multiple of the quantity per reel.

**4.** Consult your OMRON representative for inquiries about lead-free tin solder.

**5.** Solder plating (specified by -1 at the end of the model number) ended production March 2006.

### Pin Number Specifications

Refer to the following website for the latest information. <http://www.omron.co.jp/ecb/>

# ZIF Slide-locking Connector (0.5-mm Pitch)

# XF2J

## Top-entry ZIF Connector

- Low on-board profile of only 4.15 mm.
- Vacuum contact surface on top of the connector for automatic mounting.
- Models with reverse terminal arrangement also available.
- Applicable FPC thickness of 0.3 mm.

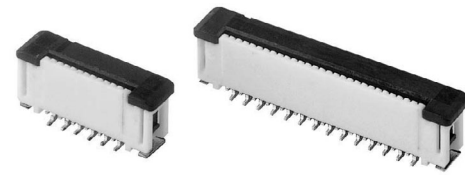

RoHS Compliant

## ■ Ratings and Specifications

XF2J-□□24-1□A

Rated current	0.5 A AC/DC
Rated voltage	50 V AC/DC
Contact resistance	30 mΩ max. (at 20 mV max., 100 mA max.)
Insulation resistance	100 MΩ min. (at 250 V DC)
Withstand voltage	250 V AC for 1 min. (leakage current: 1 mA max.)
Insertion tolerance	30 times
Ambient operating temperature	-30 to 85°C (with no icing or condensation)

## ■ Materials and Finish

XF2J-□□24-1□A

Housing	PA46 resin (UL94V-0)/natural
Slider	PPS resin (UL94V-0)/black LCP resin (UL94V-0)/black
Contacts	Spring copper alloy/nickel substrate (2 μm), gold-plated contacts (0.15 μm)
Hold-down	Spring copper alloy/fused-tin plating (1.5 μm)

## ■ Dimensions

XF2J-□□24-1□□

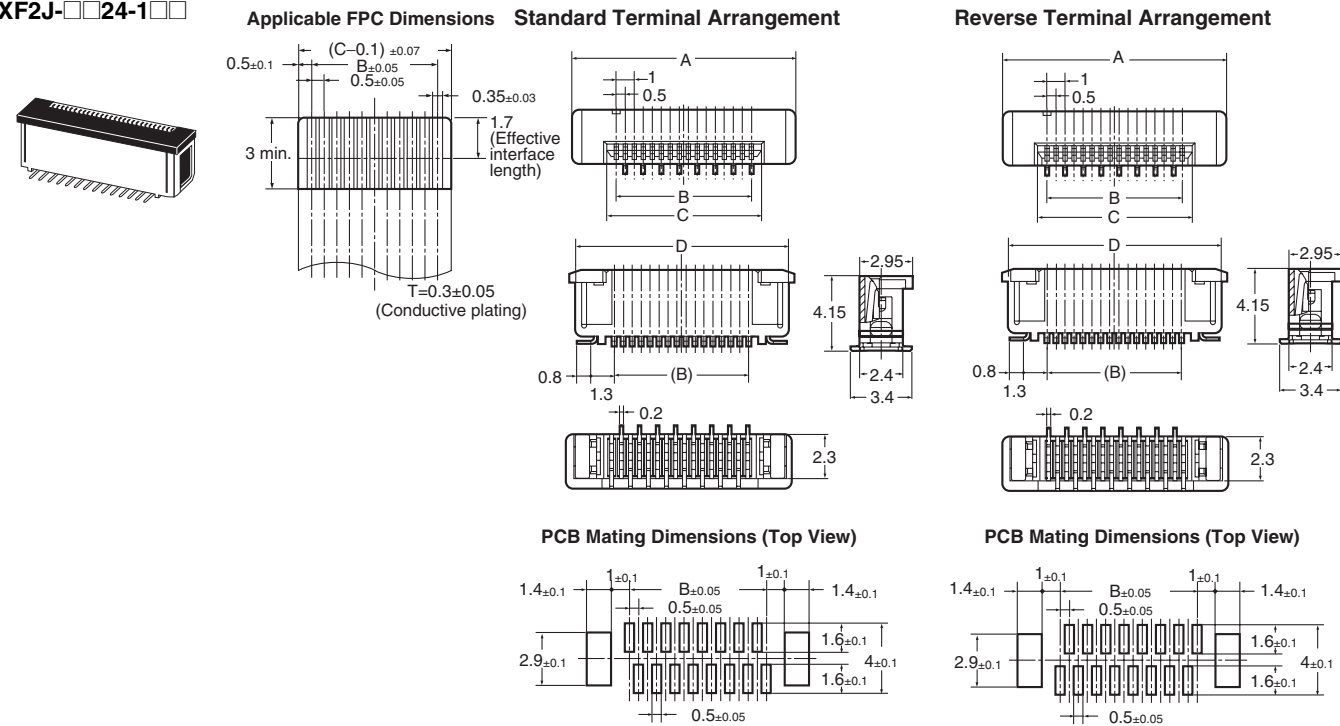

Table of Dimensions

Pins (See note 2.)	Model (See note 1.)		A	B	C	D	Pins (See note 2.)	Model (See note 1.)		A	B	C	D
	Standard Terminal Arrangement	Reverse Terminal Arrangement						Standard Terminal Arrangement	Reverse Terminal Arrangement				
6	XF2J-0624-11□	XF2J-0624-12□	7.5	2.5	3.6	6.9	20	XF2J-2024-11□	XF2J-2024-12□	14.5	9.5	10.6	13.9
8	XF2J-0824-11□	XF2J-0824-12□	8.5	3.5	4.6	7.9	22	XF2J-2224-11□	XF2J-2224-12□	15.5	10.5	11.6	14.9
10	XF2J-1024-11□	XF2J-1024-12□	9.5	4.5	5.6	8.9	24	XF2J-2424-11□	XF2J-2424-12□	16.5	11.5	12.6	15.9
12	XF2J-1224-11□	XF2J-1224-12□	10.5	5.5	6.6	9.9	26	XF2J-2624-11□	---	17.5	12.5	13.6	16.9
14	XF2J-1424-11□	---	11.5	6.5	7.6	10.9	28	XF2J-2824-11□	---	18.5	13.5	14.6	17.9
16	XF2J-1624-11□	XF2J-1624-12□	12.5	7.5	8.6	11.9	30	XF2J-3024-11□	---	19.5	14.5	15.6	18.9
18	XF2J-1824-11□	XF2J-1824-12□	13.5	8.5	9.6	12.9	---	---	---	---	---	---	---

## ■ Ordering Information

Pins (See note 2.)	Model (See note 1.)		Quantity per reel (See note 3.)
	Standard Terminal Arrangement	Reverse Terminal Arrangement	
6	XF2J-0624-11□	XF2J-0624-12□	1,000
8	XF2J-0824-11□	XF2J-0824-12□	
10	XF2J-1024-11□	XF2J-1024-12□	
12	XF2J-1224-11□	XF2J-1224-12□	
14	XF2J-1424-11□	---	
16	XF2J-1624-11□	XF2J-1624-12□	
18	XF2J-1824-11□	XF2J-1824-12□	
20	XF2J-2024-11□	XF2J-2024-12□	
22	XF2J-2224-11□	XF2J-2224-12□	
24	XF2J-2424-11□	XF2J-2424-12□	
26	XF2J-2624-11□	---	
28	XF2J-2824-11□	---	
30	XF2J-3024-11□	---	

**Note:** 1. The symbol in the box at the end of the model number indicates the type of plating.

A: Gold-plated (RoHS compliant).

2. Consult your OMRON representative for inquiries related to pin number specifications.

3. Order an integer multiple of the quantity per reel.

4. Consult your OMRON representative for inquiries about lead-free tin solder.

5. Solder plating (specified by -11 or -12 at the end of the model number) ended production March 2006.

### Pin Number Specifications

Refer to the following website for the latest information. <http://www.omron.co.jp/ecb/>

# Common Precautions for XF Connectors

## ■ Safety Precautions

### Precautions for Correct Use

#### ● All Models

##### Operating

- Make sure that the FPC has been inserted correctly and not backward.  
Inserting the FPC incorrectly with the FPC connecting face not aligned with the customer's design specifications may damage the contacts and equipment may malfunction.
- Insert the FPC fully to the back of the connector. Failing to do so may result in a loss of contact reliability.
- When inserting and removing the FPC, applying pressure from above or below, left to right or at an angle may cause the FPC contacts to become damaged or detached and may result in contact failure.

##### Designing

- Gently pull out the FPC taking care not to apply force directly to the connector.  
Bending the FPC in the area where it enters the connector or applying force to the FPC itself may result in contact failure.
- When installing the FPC at a location or on equipment that will subject the FPC to repeated vibration or movement, secure the FPC prior to use.
- Use FPCs that conform to the appropriate specifications and size as stated by OMRON.  
When using a different FPC, or an F/F, contact OMRON.
- Use the same metal for the FPC plating and the connector plating.
- "Whiskers" may protrude from the FPC film of some lead-free FPCs. Be careful when using these units.
- Ensure a metal mask thickness of  $t = 0.12$  to  $0.15$  mm.  
The recommended metal mask open area is 90% of the printed circuit board mating dimensions given in the dimensions diagrams.

##### Mounting

- Do not perform mounting (reflow or manual soldering) with the FPC inserted in the connector. Doing so may result in contact failure.
- The reflow conditions are as stated in OMRON's specifications and guidelines. These conditions, however, depend on the type of solder, the manufacturer, the amount of solder, the size of the circuit board, and the other mounting materials. Confirm the mounting conditions before using the connectors.
- When mounting the connector by manual soldering, observe the following precautions to ensure contact reliability.
  1. Conditions for manual soldering:  $350 \pm 10^\circ\text{C}$  for  $3 \pm 1$  s
  2. Do not apply an excessive amount of solder. Excessive solder will cause the flux to rise.
  3. Do not apply the soldering iron to the mount attachments using force. Doing so may cause the connectors to change shape.
  4. Do not apply the soldering iron to any parts of the connector other than the mount attachments. Doing so may cause the connector to change shape.

##### Board Mounting Precautions

- Be careful of board warping. The connector flatness is 0.1 mm max. A large amount of warping, however, may result in soldering faults.
- Do not apply excessive force on the connector before mounting it. The connector may be damaged, resulting in faulty contacts. Do not insert the FPC and lock the slider before mounting the connector.
- Be careful to not apply an excessive load on the board when performing the following actions.
  1. Dividing multi-cavity boards.
  2. Securing a board with screws.

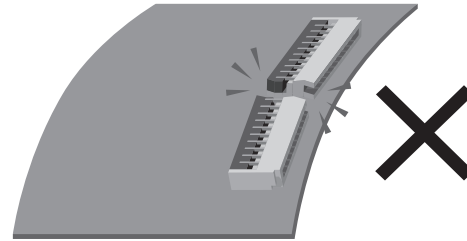

##### Storage

1. Do not store the connectors in locations subject to dust or high humidity.
2. Do not store the connectors in locations close to sources of gasses such ammonia gas or sulfide gas.

**● All Models****Operating**

- Do not lock or unlock the slider with excessive force. Doing so may result in damage to the connector or contact failure.
- Do not use the slider again if it becomes detached.
- When inserting and removing the FPC, be sure to check that the slider has been unlocked first. Using the FPC in the follow ways may damage the FPC, change the shape of the contacts, or result in contact failure.
  1. Removing the FPC when the slider is still locked.
  2. Removing the FPC by pulling it up and down or from left to right or twisting it sideways.

**● Backlocking Models****Operating**

- Do not lock the slider without an FPC inserted. Locking the slider without an FPC inserted will cause a decrease in the dimensions between the contacts and consequently an increase in the force required to insert an FPC.
- When locking the slider, apply pressure with your fingertips to both sides of the slider, then twist the slider until it comes away from the unit. Failing to lock the slider properly may result in contact failure.
- Do not apply force horizontally to the PCB when locking the slider. Doing so may result in damage to the connector or contact failure.
- When unlocking the slider, place your fingers on either side or on the entire slider and slowly lift the slider up and away. Do not engage the slider past its initial location during the unlocking process. Doing so may result in damage to the connector or contact failure.

**Designing**

- When designing the board, be sure to allow locking and operating space for the slider.

**Mounting**

- Do not perform reflow or manual soldering with the FPC inserted in the connector and the slider in the locked position. Doing so may result in contact failure.

**● Frontlocking Models****Operating**

- When unlocking the slider, use your fingernail to rotate and lift the slider. The slider cannot be opened to an angle of more than 125°C. Do not apply force on the slider beyond that point. Doing so may result in damage to the connector or contact failure. When locking the slider, apply pressure with your fingertips to the center of the slider, then twist the slider until it comes away from the unit. Failing to lock the slider properly may result in contact failure.

**● Slidelocking Models****Operating**

- When locking the slider, apply pressure to both sides or the entire slider, then push the slider all the way in. Not doing so may result in contact failure.

**Designing**

- When designing the board, be sure to allow unlocking and operating space for the slider.

# Operating the XF Rotary Backlock

## FPC Connector Part Names

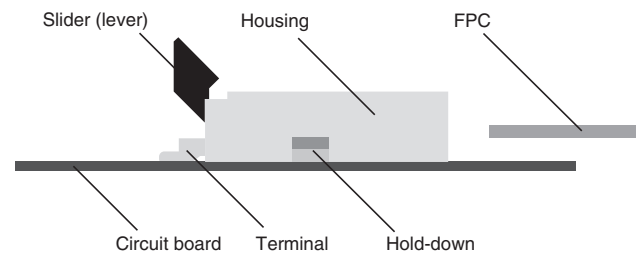

## Handling Methods

### Inserting the FPC

1. Insert the FPC all the way to the back of the connector.

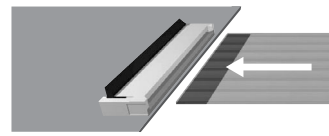

The slider (lever) shown open



2. Activate the slider (lever) and lock the FPC in place.

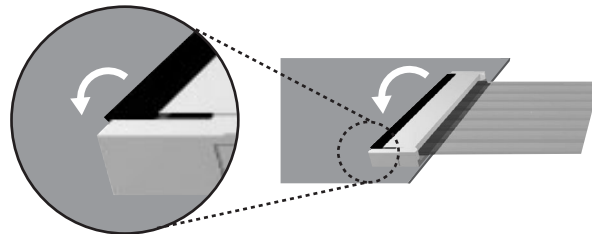

The slider (lever) shown locked

### Removing the FPC

1. Move the slider (lever) upwards to disengage the locking mechanism.

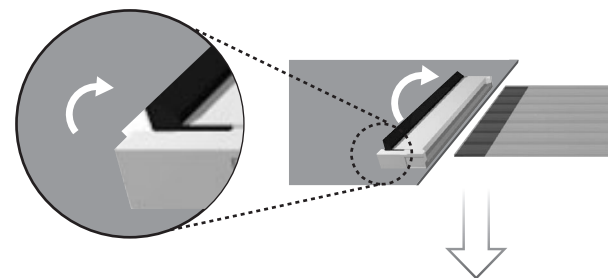

2. Once the lock has been disengaged, pull the FPC out.

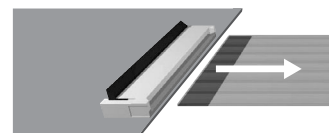

## Precautions during Use

### Operating

1. Do not lock the slider (lever) without an FPC inserted. Locking the slider (lever) without an FPC inserted will increase the force required to insert an FPC.

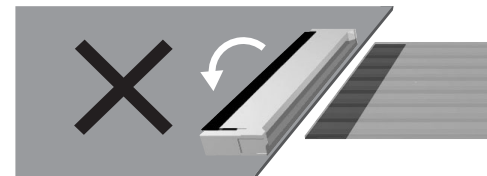
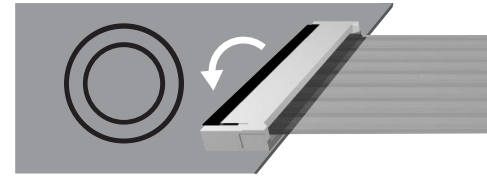

2. Do not lock or unlock the slider (lever) with excessive force. Doing so may result in damage to the connector or contact failure.

Do not use a slider (lever) if it becomes detached.

3. When locking the slider (lever), apply pressure with your fingertips to both sides of the slider (lever) and then twist the slider (lever) until it comes away from the unit. Failing to lock the slider (lever) properly may result in contact failure.

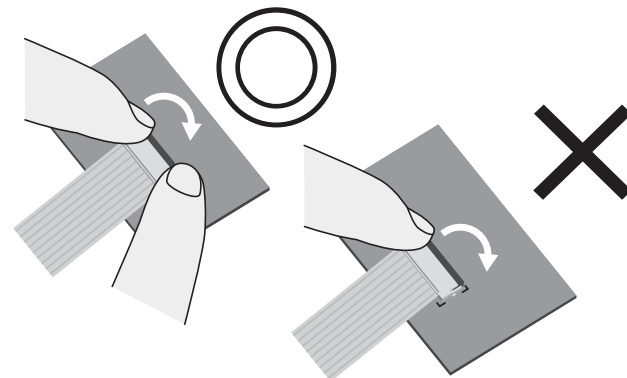

Do not apply force horizontally to the PCB when locking the slider (lever). Doing so may result in damage to the connector or contact failure.

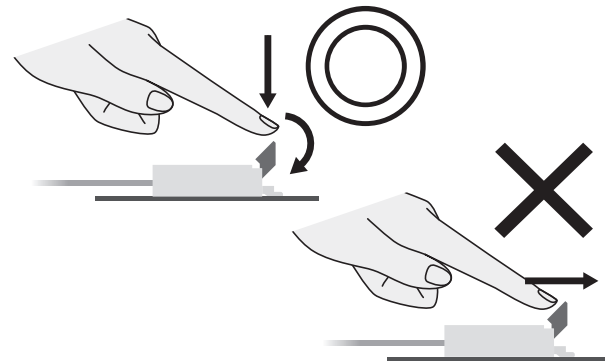

4. When unlocking the slider (lever), place your fingers on either side or the entire slider (lever) and slowly lift the slider (lever) up and away.

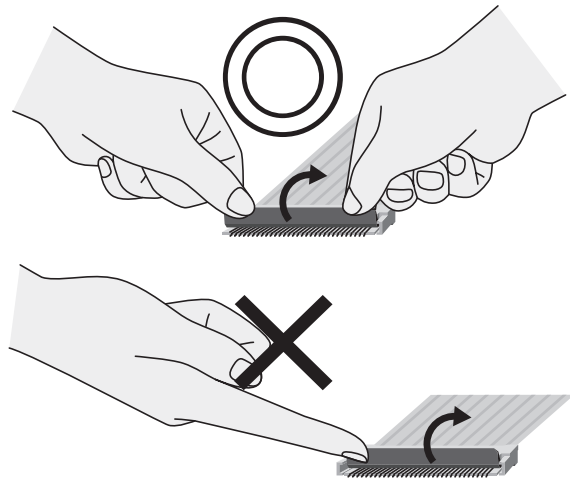

Do not engage the slider (lever) past its initial location during the unlocking process. Doing so may result in damage to the connector or contact failure.

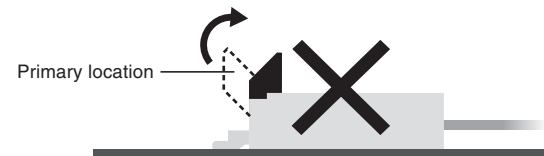

Performing the following action may cause the terminals to change shape or otherwise cause contact failures.

- Using tweezers to unlock the slider (lever).

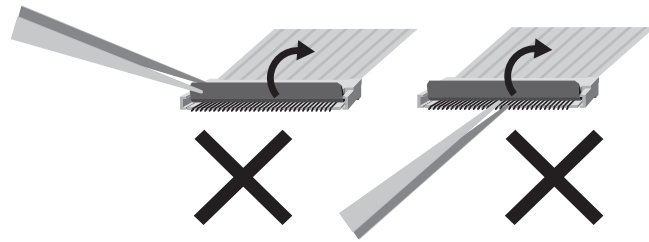

5. When inserting and removing the FPC, be sure to check that the slider (lever) has been unlocked first.

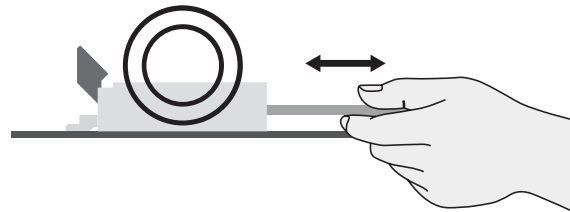

Using the FPC in the follow ways may damage the FPC, change the shape of the contacts, or result in contact failure.

- Removing the FPC when the slider (lever) is still locked.

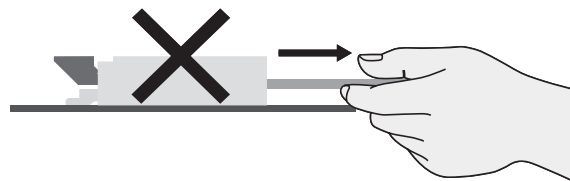

- Removing the FPC by pulling it up and down or from left to right or twisting it sideways.

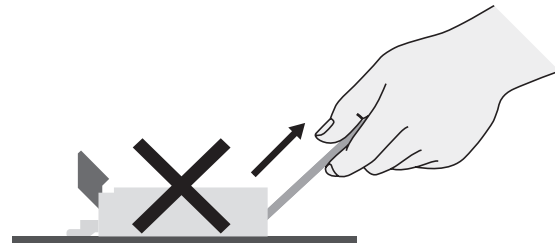

6. Make sure that the FPC has been inserted correctly and not backward.  
Inserting the FPC incorrectly with the connecting face not aligned with the customer's design specification may damage the contacts and equipment may malfunction.

#### Mounting

1. Do not perform reflow or manual soldering with the FPC inserted in the connector and the slider (lever) in the locked position. Doing so may result in contact failure.
2. The reflow conditions are as stated in OMRON's specifications and guidelines. These conditions, however, depend on the type of solder, the manufacturer, the amount of solder, the size of the circuit board, and the other mounting materials. Confirm the mounting conditions before proceeding.

#### Designing

1. Gently pull out the FPC taking care not to apply force directly to the connector. Bending the FPC in the area where it enters the connector or applying force to the FPC itself may result in contact failure.
2. When installing the FPC at a location or on equipment that will subject the FPC to repeated vibration or movement, secure the FPC prior to use.
3. Use the FPCs that conform to the appropriate specifications and size as stated by OMRON. When using a different FPC, or an F/F, contact OMRON.
4. Use the same metal for the FPC plating and the connector plating.
5. "Whiskers" may protrude from the FOC film of some lead-free FPCs. Be careful when using these units.
6. When designing the board, be sure to allow locking and operating space for the slider (lever).

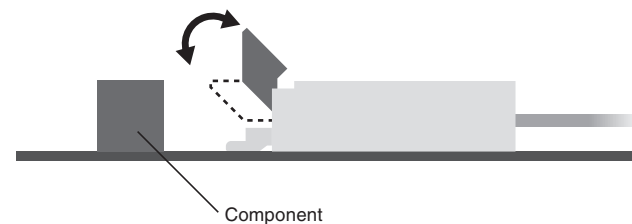

7. Make sure that the metal mask thickness is within the appropriate specifications and size as stated by OMRON. The recommended metal mask open area is 90% of the printed circuit board mating dimensions given in the dimensions diagrams.



# Operating the XF Rotary Front Lock

## FPC Connector Part Names

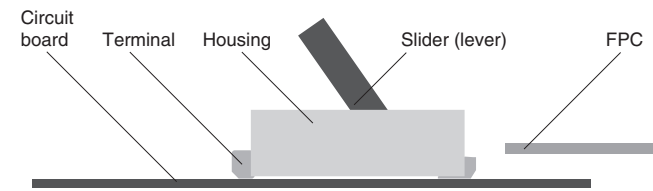

## Handling Methods

### Inserting the FPC

1. Use your fingernail on the center of the slider to twist the slider until it comes away from the unit.

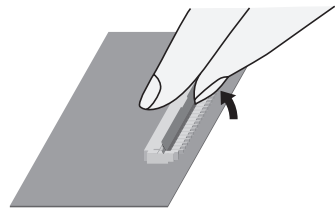

2. Securely insert the FPC so that it is perpendicular to the connector and horizontal to the connector.



3. When locking the slider, apply pressure with your fingertips to the center of the slider, then twist the slider until it comes away from the unit.

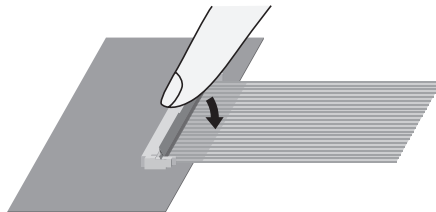

### Removing the FPC

1. Unlock the slider by pushing it up, then remove the FPC.

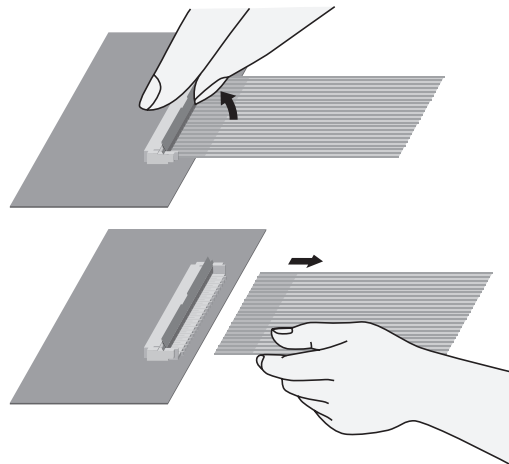

## Precautions during Use

### Operating

1. The slider mechanism rotates around a rotary shaft. Operate the slider in a rotating movement.

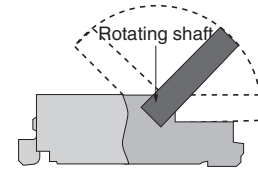

2. The slider cannot be opened to an angle of more than 125°. Do not apply force on the slider beyond that point. Doing so may result in damage to the connector or contact failure. Do not use the slider if it becomes detached.

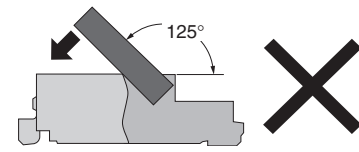

3. Lock and unlock the slider using the center of the slider. Using the end of the slider may result in incomplete locking, damage, or contact failure.
4. As shown in the following figure, do not touch the terminals with your fingernail or fingers if using the slider without the FPC inserted. Doing so may cause the terminals to change shape and result in contact failure.

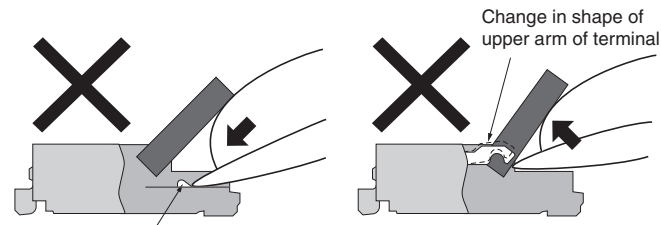

5. Using the FPC in the follow ways may damage the FPC, change the shape of the contacts, or result in contact failure.
  - Removing the FPC when the slider (lever) is still locked.

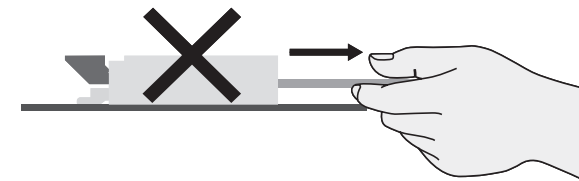

- Removing the FPC by pulling it up and down or from left to right or twisting it sideways.

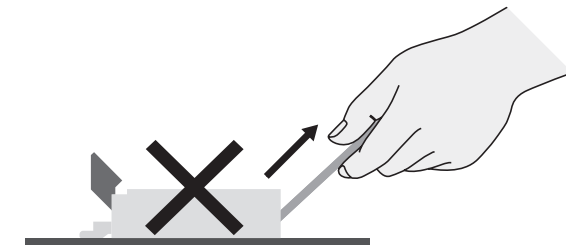

6. Make sure that the FPC has been inserted correctly and not backward. Inserting the FPC incorrectly with the connecting face not aligned with the customer's design specification may damage the contacts and equipment may malfunction.

**Mounting**

1. Do not perform reflow or manual soldering with the FPC inserted in the connector and the slider (lever) in the locked position. Doing so may result in contact failure.
2. The reflow conditions are as stated in OMRON's specifications and guidelines. These conditions, however, depend on the type of solder, the manufacturer, the amount of solder, the size of the circuit board, and the other mounting materials. Confirm the mounting conditions before proceeding.

**Designing**

1. Gently pull out the FPC taking care not to apply force directly to the connector. Bending the FPC in the area where it enters the connector or applying force to the FPC itself may result in contact failure.
2. When installing the FPC at a location or on equipment that will subject the FPC to repeated vibration or movement, secure the FPC prior to use.
3. Use the FPCs that conform to the appropriate specifications and size as stated by OMRON. When using a different FPC, or an F/F, contact OMRON.
4. Use the same metal for the FPC plating and the connector plating.
5. "Whiskers" may protrude from the FPC film of some lead-free FPCs. Be careful when using these units.
6. Make sure that the metal mask thickness is within the appropriate specifications and size as stated by OMRON. The recommended metal mask open area is 90% of the printed circuit board mating dimensions given in the dimensions diagrams.



## Lead-Free Solder

To comply with the prohibition of lead use stipulated by the RoHS Directive, SnPb solder plating FPC connectors must become lead free. OMRON implemented the plan to end production of solder plating as of March 2006. Instead of solder plating (SnPb) connectors, OMRON is providing reflow (Sn) plating connectors\* with whisker prevention and Gold (Au) plating connectors.

\* Applicable Models

XF2M-□□15-1L  
XF2L-□□□5-1  
XF2J-□□24-1□

### Precautions

- "Whiskers" may occur on the FPC film when using lead-free solder. Check for "whiskers" before using the connectors.
- Use the same metal for the FPC plating and the connector plating. Using more than one type of metal may cause corrosion.

For inquiries, contact your OMRON sales representative.

**ALL DIMENSIONS SHOWN ARE IN MILLIMETERS.**

To convert millimeters into inches, multiply by 0.03937. To convert grams into ounces, multiply by 0.03527.

Cat. No. G011-E1-06 **In the interest of product improvement, specifications are subject to change without notice.**

### OMRON Corporation

Electronic Components Company

**Connector Division**

Sakado 3-2-1, Takatsu-ku, Kawasaki-city,  
Kanagawa, 213-0012 Japan  
Tel: (81)44-812-3432/Fax: (81)44-812-3447

*Regional Headquarters*

**OMRON ELECTRONIC COMPONENTS  
EUROPE B.V.**

Wegalaan 57, 2132 JD Hoofddorp,  
*THE NETHERLANDS*  
Tel: 31-23-568-1200/Fax: 31-23-568-1212

**OMRON ELECTRONIC COMPONENTS LLC  
U.S.A.**

55 East Commerce Drive, Suite B, IL 60173  
Tel: 1-847-882-2288/Fax: 1-847-882-2192

**OMRON ELECTRONIC COMPONENTS  
PTE. LTD.**

750B Chai Chee Road #01-02  
Technopark@Chai Chee,  
*SINGAPORE 469002*  
Tel: 65-6446-7400/Fax: 65-6446-7411

**OMRON ELECTRONIC COMPONENTS  
TRADING (SHANGHAI) LTD.  
SHANGHAI OFFICE**

Rm2503, Raffles City Shanghai (Office Tower),  
No.268 Xi Zang Middle Road,  
Huang Pu District,  
*Shanghai, 200001 CHINA*  
Tel: 86-21-6340-3737/Fax: 86-21-6340-3757

## X-ON Electronics

Largest Supplier of Electrical and Electronic Components

*Click to view similar products for [Omron](#) manufacturer:*

Other Similar products are found below :

[G9ED-1-B-AQ-DC24](#) [E3X-SD11 2M](#) [S8VM-10024C](#) [R88A-CCW002P2](#) [S82Y-VM30D](#) [H3AM-NS-A AC100-240](#) [G3NA-440B-2 DC5-24](#)  
[XF2J-0824-11A-R100](#) [G3NA-425B-2 DC5-24](#) [MY2N-DC24](#) [XF2J-0824-12A](#) [G8JN-1C7T-R-DC12](#) [G8VA-1A4T-R01-DC12](#) [G8HE-1A7T-](#)  
[R-DC12](#) [XF2W-2415-1A](#) [XF2U-3015-3A](#) [G8V-RH-1A7T-R-DC12](#) [LY1D-2-5S-AC120](#) [M165-JR-24D](#) [M16-TG-24D](#) [CS1G-CPU43-E](#)  
[M22CAT1](#) [61F-GP-NT AC110](#) [M7E-01DGN2-B](#) [M7E-02DGN2](#) [M7E-08DRN2](#) [M7E-20DRN1](#) [M7E-HRN2](#) [M8PHWS](#) [D2HW-BL211DL](#)  
[D2VW-5L2A-2MS](#) [F03-02 SUS316](#) [F150LTC20](#) [F3SJ-A0245P30](#) [F3STGRNSMC21M1J8](#) [F3UVHM](#) [MG2-US-AC24](#) [MGN1C-DC24](#)  
[MK2EP-UA-AC6V](#) [MK2PNIAC240](#) [MK310E-DC24](#) [MKS2XTIN-11 DC110](#) [MM4KPAC120NC](#) [MM4XPAC120](#) [G2Q-184P-V-DC5](#) [G2R-](#)  
[1114P-V-US-DC5](#) [G2R13SNDDC24](#) [G2R-1-T 5VDC](#) [G2R-2 240VAC](#) [G2R-2 48VAC](#)