

XM7

USB Connectors

Small Interface Connectors That Conform to USB Standards

- Compliant with the USB 2.0 standard.

mini-USB Connectors

- Insertion durability of 5,000 times.
- Lineup includes models with right-angle DIP terminals and SMT terminals.
- Models with SMT terminals are available with reel packaging.



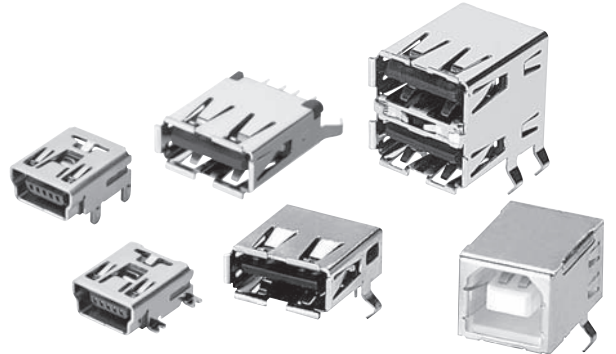

USB Connectors

- Insertion durability of 1,500 times.
- USB A-type sockets for mounting on personal computers and USB hubs. USB B-type sockets for mounting on printers, scanners, mice, and other peripheral devices for computers.

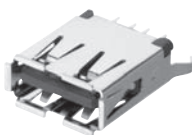
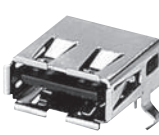

RoHS Compliant

Connectors

USB 2.0 Mini-USB Connectors	Appearance	Right-angle DIP Terminals 	Right-angle SMT Terminals 		
	Model	XM7D-0512		Packaged on stick: XM7D-0514, Packaged on reel: XM7D-0514-R	
	Page	Page 2			
USB 2.0 Connectors	Appearance	Straight DIP Terminals 	Right-angle DIP Terminals 	Right-angle DIP Terminals 	Right-angle DIP Terminals 
	Model	XM7A-0441	XM7A-0442	XM7A-0442-A	XM7B-0442
	Page	Page 4			

XM7D USB 2.0 mini-USB Connectors

Model Number Legend

XM7D-05 1 □-□
1 2 3 4 5

1 Type

D: mini-B-type socket

2 No. of Contacts

05: 5 contacts

3 Plating Specification

1: Gold plating

4 Terminal Shape

2: Right-angle DIP terminals

4: Right-angle SMT terminals

5 Special Specification



(Right-angle SMT Terminals Only)

Blank : Packaged on tray or stick

R : Packaged on reel

Ordering Information

●Sockets

	Right-angle DIP terminals	Right-angle SMT terminals
Appearance		
Model	XM7D-0512	XM7D-0514
Minimum ordering quantity (pieces)	100/tray	50/stick
Model	-	XM7D-0514-R
Quantity per reel (pieces)*	-	500/reel*

* Please order by integer multiple of the quantity per reel.

Ratings and Characteristics

Rated current	1 A
Rated voltage	30 VAC
Contact resistance	50 mΩ max. (at 20 mV, 100 mA max.)
Insulation resistance	100 MΩ min.
Dielectric strength	100 VAC for 1 min (leakage current: 0.5 mA max.)
Insertion durability	5,000 times
Ambient operating temperature	0 to 50°C (with no icing or condensation)

Materials and Finish

Housing	LCP/Black	
Contacts	Mating end	Copper alloy/gold plating
	Terminals	Copper alloy/tin plating
Shell	Copper alloy/nickel plating	

Dimensions

XM7D-0512

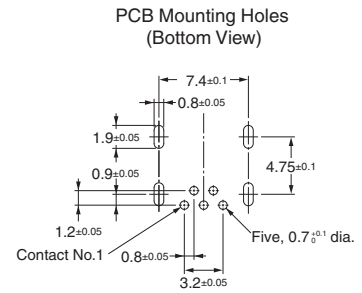
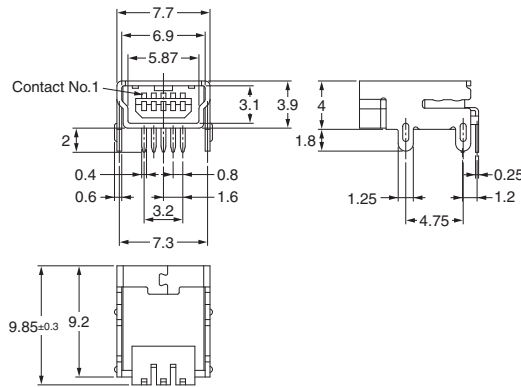

XM7D-0514
XM7D-0514-R

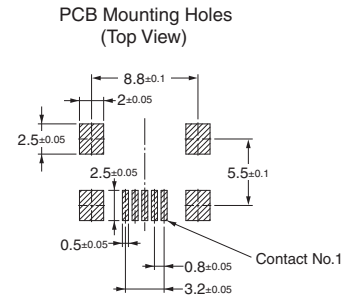
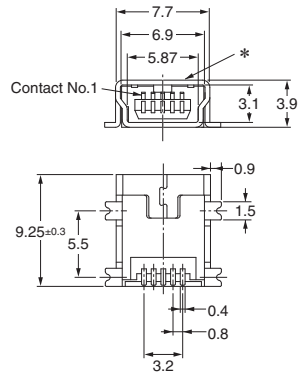

* The adhesive tape is on the top surface of the Connectors.

XM7

XM7A/B USB 2.0 USB Connectors

Model Number Legend

XM7□-04 4 □-□
 1 2 3 4 5

1 Type

A: A-type socket
 B: B-type socket

2 No. of Contacts

04: 4 contacts

3 Plating Specification

4: Gold plating

4 Terminal Shape



1: Straight DIP terminals
 2: Right-angle DIP terminals

5 Special Specification (A-type Sockets Only)

Blank : Single socket
 A : Double stacked sockets

Ordering Information

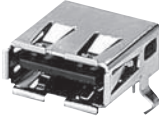
●Sockets

Item	Type	Single A-type Socket	Single A-type Socket	Double Stacked A-type Sockets	Single B-type Socket
Appearance		Straight DIP Terminals	Right-angle DIP Terminals	Right-angle DIP Terminals	Right-angle DIP Terminals
					
Model		XM7A-0441	XM7A-0442	XM7A-0442-A	XM7B-0442
Minimum ordering quantity (pieces)		120	150	120	150

Ratings and Characteristics

Rated current	1 A
Rated voltage	30 VAC
Contact resistance	30 mΩ max. (at 20 mV, 100 mA max.)
Insulation resistance	1,000 MΩ min. (at 500 VDC)
Dielectric strength	750 VAC for 1 min (leakage current: 0.5 mA max.)
Insertion durability	1,500 times
Ambient operating temperature	-40 to 60°C (with no icing or condensation)

Materials and Finish

Housing		PBT A-type Sockets: Black B-type Sockets: White
Contacts	Mating end	Copper alloy/gold plating
	Terminals	Copper alloy/tin alloy plating
Shell		Copper alloy/tin plating

■ Dimensions

**XM7A-0441
Single A-type Socket**

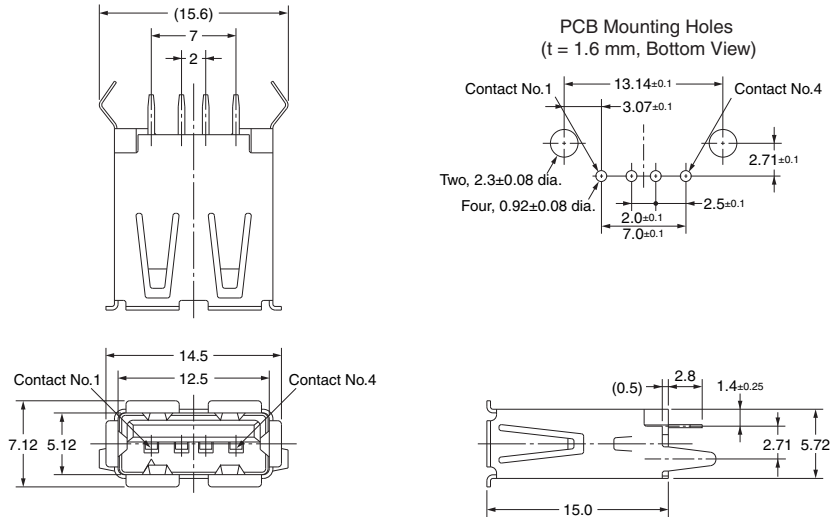
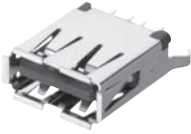

**XM7A-0442
Single A-type Socket**

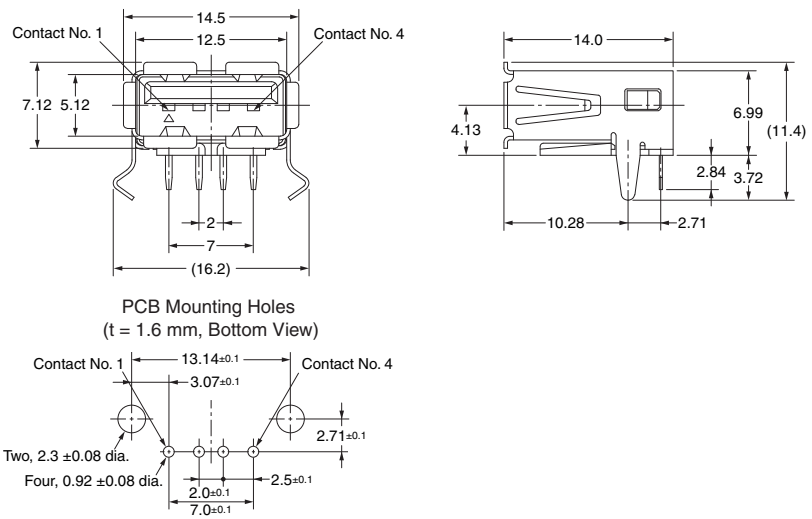
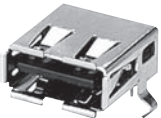

**XM7A-0442-A
Double Stacked A-type Sockets**

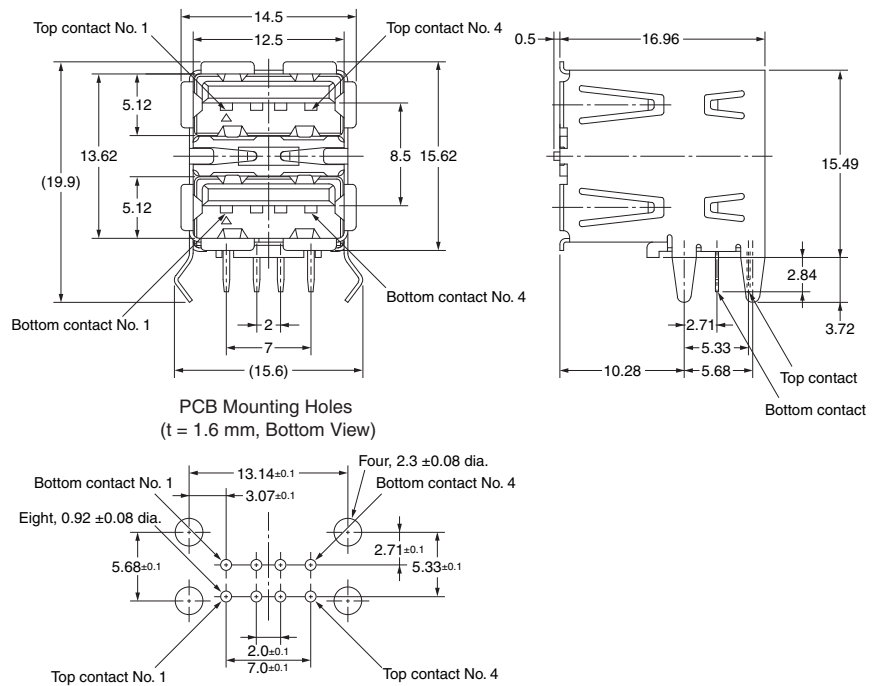
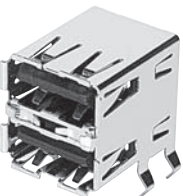

XM7

XM7B-0442 Single B-type Socket

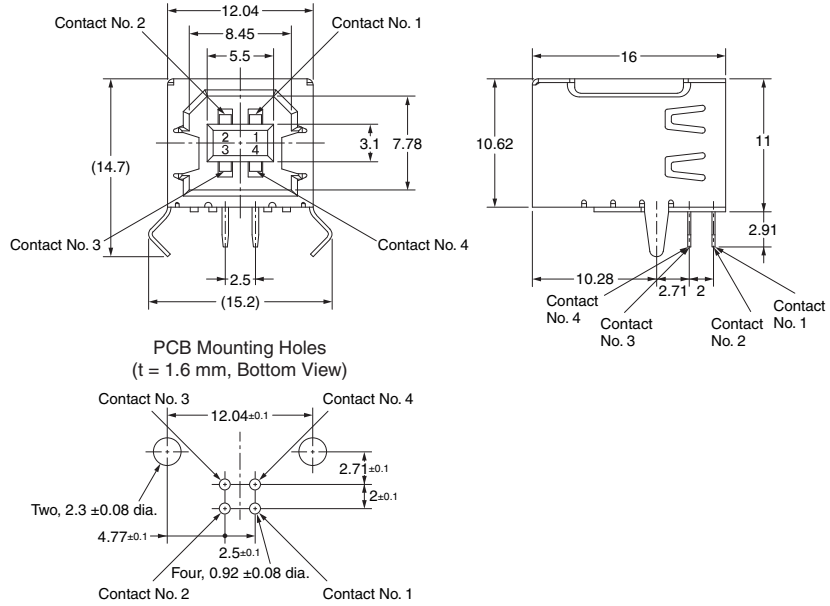

■Accessories (sold separately)

(Unit: mm)

●Dust cover (For XM7A Single A-type socket) XM7Z-0001 (A type)

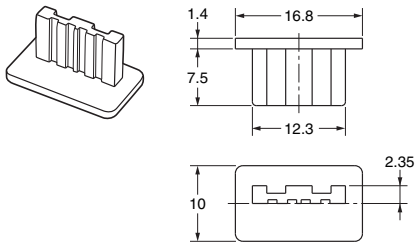

●Dust cover (For XM7B sockets) XM7Z-0002 (B type)

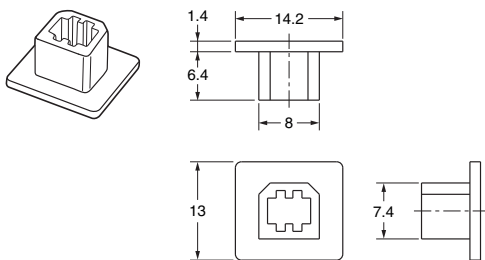

Characteristics/Material

Ambient operating temperature	-40 to 60°C (with no icing or condensation)
Material	PE

Model	Applicable	Minimum ordering quantity (pieces)
XM7Z-0001	XM7A (Single A-type Socket)	50
XM7Z-0002	XM7B	

Note: Dust covers cannot be used for Double Stacked A-type sockets.

Precautions

Precautions for Correct Use

●Automatic Soldering

Reference Information: Automated Soldering Conditions (Jet Flow)

- (1) Soldering temperature: 250 ±5°C
- (2) Continuous soldering time: 5 ±1 s max.

●Soldering Conditions

- Reference Information: Reflow Conditions
 - Maximum temperature: 260°C
 - Time: 5 to 15 s max.

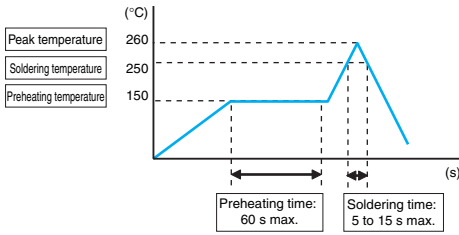

These conditions, however, depend on the type of solder, the manufacturer, the amount of solder, the size of the board, and the other mounting materials.

●Metal Mask for Cream Solder Printing

We recommend a metal mask thickness of 0.15 mm when printing cream solder.

The appropriate conditions, however, depend on the type of solder, the manufacturer, the amount of solder, the size of the circuit board, other mounting materials, and other conditions.

●Terminal Shapes

The terminals will deform if they are subjected to an excessive load, which will in turn reduce solderability when mounting. Do not drop the Connectors or handle them carelessly. Do not connect anything when the Connectors are not mounted to a board. Doing so may deform the terminals.

●Mating

Do not connect the connectors in the wrong direction. Doing so will damage the connectors.

●Using an Automatic Solder Bath after Reflow

Mask the mating portion with tape before you perform automatic soldering to prevent flux or solder from entering the mating portion of the Connector. Select and use a suitable masking tape.

●Application Precautions

- Confirm that there is no excessive misalignment or inclination in the mating contact portion between the plug and socket before mating the Connector. Make sure that the Connector is mated all the way to the back. If the Connector is not mated all the way to the back, contact reliability may be lost.
- Do not apply an extreme load during Connector insertion or removal. The Connector may be damaged, and contact failure may result. Twist the plug and socket as little as possible when mating the Connector. Not doing so may deform the terminals or housing or crack the housing.
- Do not insert a foreign object, such as tweezers, into the Connector mating contact portion. Doing so may cause the plating to peel off or deform the terminals.

●Precautions for Board Mounting

Be careful of the amount of board warping. If the board is excessively warped, soldering faults may occur.

●Storage

Do not store the Connectors in locations subject to dust or high humidity. Do not store the Connectors in locations close to sources of gasses such ammonia gas or sulfide gas.

Terms and Conditions Agreement

Read and understand this catalog.

Please read and understand this catalog before purchasing the products. Please consult your OMRON representative if you have any questions or comments.

Warranties.

- (a) Exclusive Warranty. Omron's exclusive warranty is that the Products will be free from defects in materials and workmanship for a period of twelve months from the date of sale by Omron (or such other period expressed in writing by Omron). Omron disclaims all other warranties, express or implied.
- (b) Limitations. OMRON MAKES NO WARRANTY OR REPRESENTATION, EXPRESS OR IMPLIED, ABOUT NON-INFRINGEMENT, MERCHANTABILITY OR FITNESS FOR A PARTICULAR PURPOSE OF THE PRODUCTS. BUYER ACKNOWLEDGES THAT IT ALONE HAS DETERMINED THAT THE PRODUCTS WILL SUITABLY MEET THE REQUIREMENTS OF THEIR INTENDED USE.

Omron further disclaims all warranties and responsibility of any type for claims or expenses based on infringement by the Products or otherwise of any intellectual property right. (c) Buyer Remedy. Omron's sole obligation hereunder shall be, at Omron's election, to (i) replace (in the form originally shipped with Buyer responsible for labor charges for removal or replacement thereof) the non-complying Product, (ii) repair the non-complying Product, or (iii) repay or credit Buyer an amount equal to the purchase price of the non-complying Product; provided that in no event shall Omron be responsible for warranty, repair, indemnity or any other claims or expenses regarding the Products unless Omron's analysis confirms that the Products were properly handled, stored, installed and maintained and not subject to contamination, abuse, misuse or inappropriate modification. Return of any Products by Buyer must be approved in writing by Omron before shipment. Omron Companies shall not be liable for the suitability or unsuitability or the results from the use of Products in combination with any electrical or electronic components, circuits, system assemblies or any other materials or substances or environments. Any advice, recommendations or information given orally or in writing, are not to be construed as an amendment or addition to the above warranty.

See <http://www.omron.com/global/> or contact your Omron representative for published information.

Limitation on Liability; Etc.

OMRON COMPANIES SHALL NOT BE LIABLE FOR SPECIAL, INDIRECT, INCIDENTAL, OR CONSEQUENTIAL DAMAGES, LOSS OF PROFITS OR PRODUCTION OR COMMERCIAL LOSS IN ANY WAY CONNECTED WITH THE PRODUCTS, WHETHER SUCH CLAIM IS BASED IN CONTRACT, WARRANTY, NEGLIGENCE OR STRICT LIABILITY.

Further, in no event shall liability of Omron Companies exceed the individual price of the Product on which liability is asserted.

Suitability of Use.

Omron Companies shall not be responsible for conformity with any standards, codes or regulations which apply to the combination of the Product in the Buyer's application or use of the Product. At Buyer's request, Omron will provide applicable third party certification documents identifying ratings and limitations of use which apply to the Product. This information by itself is not sufficient for a complete determination of the suitability of the Product in combination with the end product, machine, system, or other application or use. Buyer shall be solely responsible for determining appropriateness of the particular Product with respect to Buyer's application, product or system. Buyer shall take application responsibility in all cases.

NEVER USE THE PRODUCT FOR AN APPLICATION INVOLVING SERIOUS RISK TO LIFE OR PROPERTY OR IN LARGE QUANTITIES WITHOUT ENSURING THAT THE SYSTEM AS A WHOLE HAS BEEN DESIGNED TO ADDRESS THE RISKS, AND THAT THE OMRON PRODUCT(S) IS PROPERLY RATED AND INSTALLED FOR THE INTENDED USE WITHIN THE OVERALL EQUIPMENT OR SYSTEM.

Programmable Products.

Omron Companies shall not be responsible for the user's programming of a programmable Product, or any consequence thereof.

Performance Data.

Data presented in Omron Company websites, catalogs and other materials is provided as a guide for the user in determining suitability and does not constitute a warranty. It may represent the result of Omron's test conditions, and the user must correlate it to actual application requirements. Actual performance is subject to the Omron's Warranty and Limitations of Liability.

Change in Specifications.

Product specifications and accessories may be changed at any time based on improvements and other reasons. It is our practice to change part numbers when published ratings or features are changed, or when significant construction changes are made. However, some specifications of the Product may be changed without any notice. When in doubt, special part numbers may be assigned to fix or establish key specifications for your application. Please consult with your Omron's representative at any time to confirm actual specifications of purchased Product.

Errors and Omissions.

Information presented by Omron Companies has been checked and is believed to be accurate; however, no responsibility is assumed for clerical, typographical or proofreading errors or omissions.

• Application examples provided in this document are for reference only. In actual applications, confirm equipment functions and safety before using the product.
• Consult your OMRON representative before using the product under conditions which are not described in the manual or applying the product to nuclear control systems, railroad systems, aviation systems, vehicles, combustion systems, medical equipment, amusement machines, safety equipment, and other systems or equipment that may have a serious influence on lives and property if used improperly. Make sure that the ratings and performance characteristics of the product provide a margin of safety for the system or equipment, and be sure to provide the system or equipment with double safety mechanisms.

Note: Do not use this document to operate the Unit.

X-ON Electronics

Largest Supplier of Electrical and Electronic Components

Click to view similar products for [USB Connectors](#) category:

Click to view products by [Omron](#) manufacturer:

Other Similar products are found below :

[65-647-8-BK-BU](#) [950](#) [952](#) [E8144-B01021-L](#) [A-USB B-TOP-C](#) [MUSBA511N5](#) [MUSBD11135](#) [217450-1](#) [CA 6 W LD](#) [KMBVX-TH-5S-B30](#)
[896-30-004-00-000000](#) [KUSBVX-BS1N-W30](#) [KUSBX-AP-KIT-SCBLK](#) [KUSBX-AS2N-W](#) [KUSBX-SMT2AP1S-W](#) [KUSBX-SMT2AP1S-](#)
[W30](#) [935](#) [957](#) [30-498-6](#) [17-210051](#) [1734082-1](#) [30-1574](#) [30-470](#) [30-489](#) [30-541](#) [30-572-3](#) [MAB 8 SN V](#) [A-USB A-2P-C](#) [MIKROE-1451](#)
[USBFTV2PEM2G](#) [USBFTVC6ZN](#) [KUSBX-AS2N-W30](#) [KUSBX-SLAS1N-W](#) [KUSBX-SMT-AS1N-W30](#) [4689-1](#) [1-1734084-2](#) [E8110-001-](#)
[01](#) [33UBARS1-04SW11](#) [33UBAR-04SW11](#) [USBF21ZNSCC](#) [USBBFTV6ZC](#) [MUSBB151341](#) [10135326-001LF](#) [M9177/3-1](#) [USB-A-S-F-B-](#)
[VT](#) [925](#) [4198](#) [690-024-633-031](#) [KUSBEX-BSFS1N-W](#) [USBFTVC6MRG](#)