

## GENERAL DESCRIPTION

OB2004Ax is a high performance and tightly integrated secondary side synchronous rectifier for switch mode power supply system. It combines a much lower voltage drop N-channel MOSFET to emulate the traditional diode rectifier at the secondary side of Flyback converter, which can reduce heat dissipation, increases output current capability and efficiency and simplify thermal design. It can support wide range of system output voltage 3V~12V.

It is suitable for multiple mode applications including discontinuous conduction mode (DCM), quasi-resonant mode (QR) and continuous conduction mode (CCM). Specially for CCM, to guarantee system reliability, innovative property prediction algorithm is used in SR turn-off control. In addition, to balance reliability and efficiency, OB2004Ax generates a driving signal with optimized dead time with respect to the primary side PWM signal from the information on the secondary side of the isolation transformer with the help of innovative property dead time control algorithm.

The innovative property off time control effectively avoid the ring impact induced by parasitic elements so that a reliable and noise free operation of the SR system is insured.

OB2004Ax is offered in SOP8 package.

## FEATURES

- Secondary-side synchronous rectifier for 3V~12V output system
- Suitable for DCM, QR and CCM operation
- Prediction algorithm for CCM
- Internal Power MOSFET
- Accurate secondary side MOSFET Vds sensing
- SR turn on/off dead-time control for high efficiency and low thermal with immunity of interference
- Adaptive off time control effectively avoid the ring impact induced by parasitic elements
- VDD UVLO protection

## APPLICATIONS

- AC/DC 3V~12V chargers/adaptors
- Low voltage rectification circuits

## TYPICAL APPLICATION

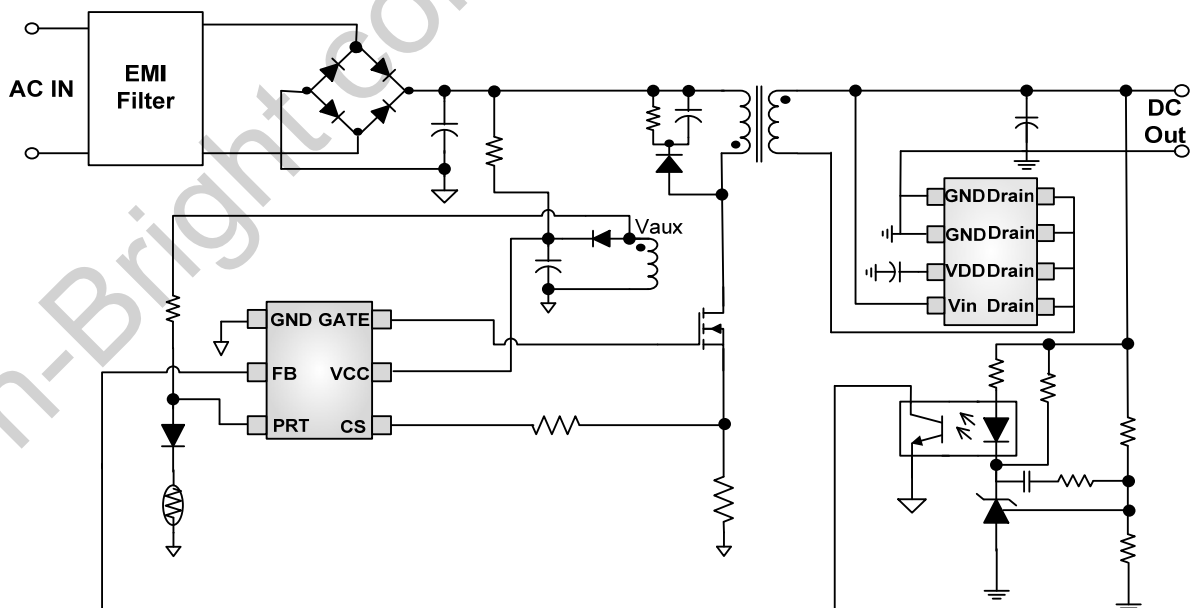

### GENERAL INFORMATION

#### Pin Configuration

The OB2004Ax is offered in SOP8 package, shown as below.

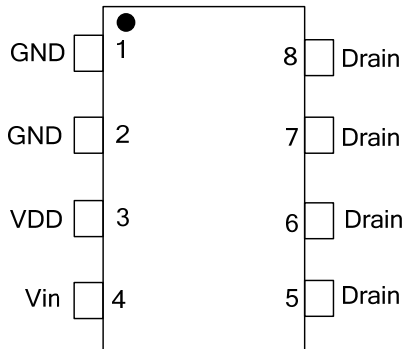

#### Ordering Information

Part Number	Description
OB2004AZCP	SOP8, Halogen-free in Tube
OB2004AZCPA	SOP8, Halogen-free in T&R
OB2004AWCP	SOP8, Halogen-free in Tube
OB2004AWCPA	SOP8, Halogen-free in T&R

#### Package Dissipation Rating

Package	R $\theta$ JA(°C/W)
SOP8	85

#### Recommended Operating Range

Symbol	Parameter	Min/Max
VDD	VDD Supply Voltage	4.2V to 5V

#### Absolute Maximum Ratings

Parameter	Value
Vin pin	-0.6V to 24V
VDD pin	-0.6V to 8V
Drain pin	-2.5V to 60V
Min/Max Operating Junction Temperature T <sub>J</sub>	-40 to 150 °C
Operating Ambient Temperature T <sub>A</sub>	-20 to 85 °C
Min/Max Storage Temperature T <sub>stg</sub>	-55 to 150 °C
Lead Temperature (Soldering, 10secs)	260 °C

**Note1:** Stresses beyond those listed under "absolute maximum ratings" may cause permanent damage to the device. These are stress ratings only, functional operation of the device at these or any other conditions beyond those indicated under "recommended operating conditions" is not implied. Exposure to absolute maximum-rated conditions for extended periods may affect device reliability.

**Note2:** -2.5V applies to minimum duty cycle during normal operation only.

#### Output Power Table

Part Number	Maximum Current	Output
OB2004AWCP	2A	
OB2004AZCP	3A	

**Note:** Maximum practical continuous power in a charger designed with sufficient drain pattern as a heat sink, at 40°C ambient.

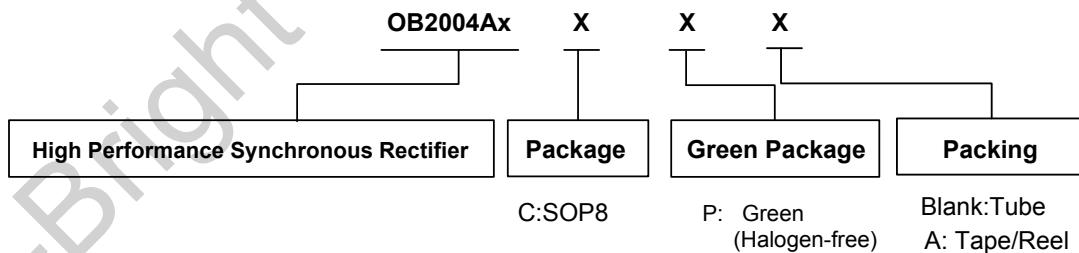

**Marking Information**



Y:Year Code  
 WW:Week Code(01-52)  
 ZZZ:Lot Code  
 C:SOP8 Package  
 P:Halogen-free Package  
 A:Character Code  
 S:Internal Code(Optional)

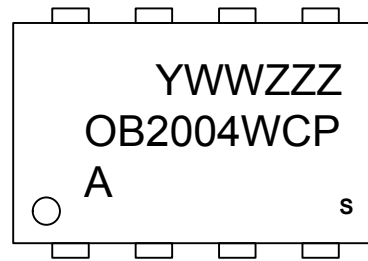

Y:Year Code  
 WW:Week Code(01-52)  
 ZZZ:Lot Code  
 C:SOP8 Package  
 P:Halogen-free Package  
 A:Character Code  
 S:Internal Code(Optional)

**TERMINAL ASSIGNMENTS**

Pin Name	I/O	Description
GND-(1,2pin)	P	Ground
VDD-(3pin)	P	Power Supply
Vin-(4pin)	I	System output voltage detection
Drain-(5,6,7,8pin)	I	SR Mosfet drain pin. This pin is connected to secondary-side winding of transformer

**BLOCK DIAGRAM**

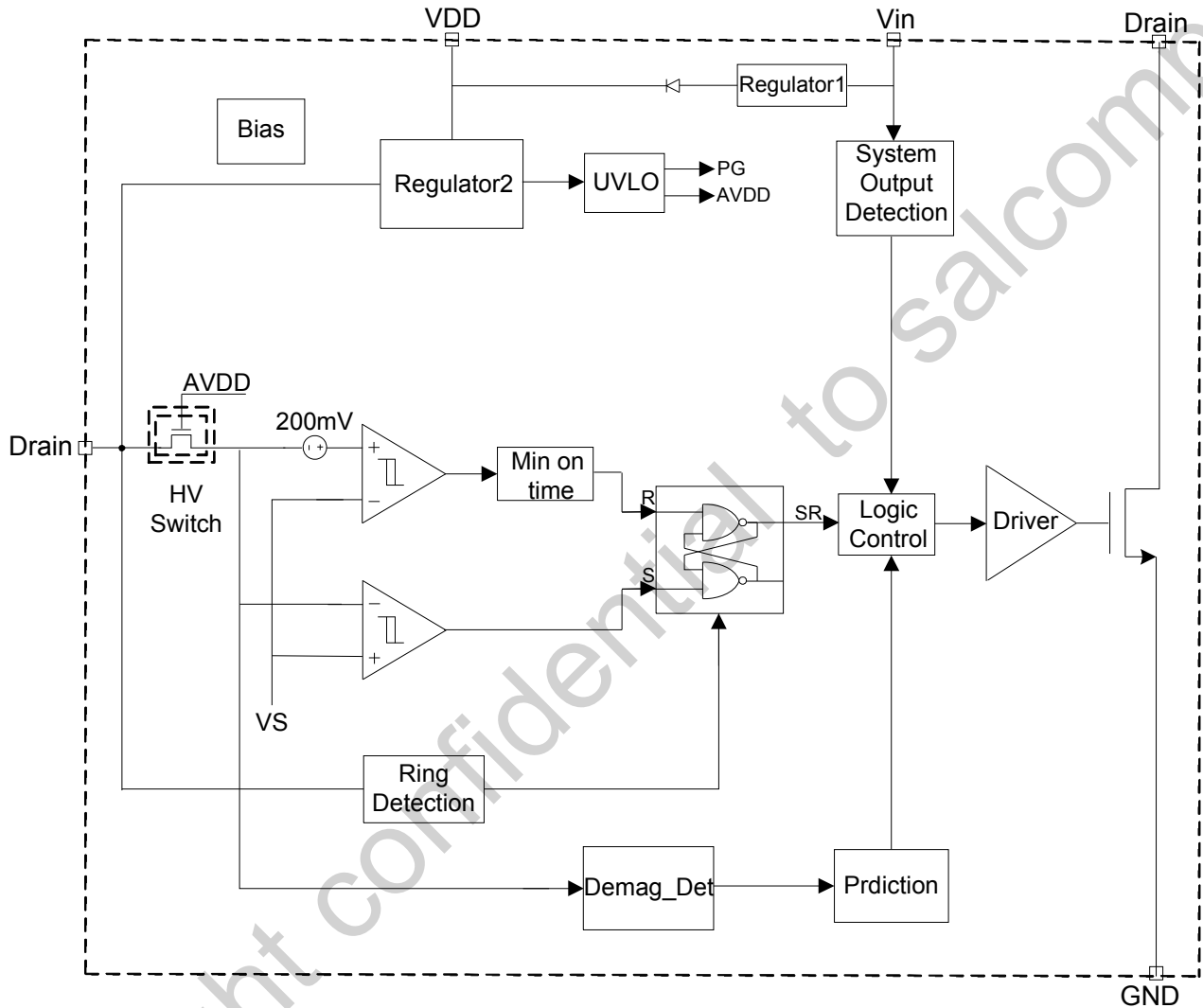

## ELECTRICAL CHARACTERISTICS

(T<sub>A</sub> = 25°C, VDD=5V, unless otherwise noted)

Symbol	Parameter	Test Conditions	Min	Typ.	Max	Unit
<b>Supply Voltage (VDD)</b>						
I_VDD_operation	Operation current	Frequency@VDrain=65KHz, VDD=5V, 1nF Cap load at GATE.		1.2	1.6	mA
		Frequency@VDrain=2KHz, VDD=5V, No load at GATE.		0.6	0.8	mA
VDD_regulation_min	VDD regulation voltage	Frequency@VDrain=50KHz, Duty=25%, High level @VDrain=20V Vin<4.5V		4.2		V
VDD_regulation_max	VDD regulation voltage	Frequency@VDrain=50KHz, Duty=25%, High level @VDrain=20V Vin>5.5V		5		V
UVLO(OFF)	VDD Under Voltage Lockout Entry			3.0		V
UVLO(ON)	VDD Under Voltage Lockout Exit (Recovery)			2.4		V
<b>VDrain Detection Section</b>						
Vth_SR_act	SR MOSFET turn on threshold voltage detection at VDrain		-150	-200	-250	mV
Vth_SR_deact	Adjustable SR MOSFET turn off threshold voltage detection at VDrain			-1		mV
Tdelay_on	SR MOSFET fast path turn-on propagation delay			70		ns
	SR MOSFET slow path turn-on propagation delay			200		ns
Tdelay_off	SR MOSFET turn-off propagation delay			75		ns
Vin_sr_disable	Voltage level at Vin when SR is disable		1.9	2.1	2.3	V
<b>CCM Prediction Section</b>						
Rpre	Prediction ratio	No sub-harmonic condition	63	66	69	%
		With sub-harmonic condition	12	15	18	%
Tsr_on_max	Maximum SR turn-on time		35	40	45	us
<b>Dead-time Control Section</b>						
Tdt_off_max	Maximum SR turn-off dead time			0.8		us

Parameter Product	BVdss(V) MOSFET Drain-Source Breakdown Voltage			Rds,on(mΩ) On resistance		
	Min	Typ.	Max	Min	Typ.	Max
OB2004AZCP	60				8	
OB2004AWCP	60				16	

Note1: Suggesting primary side controller operating at 65kHz frequency

### CHARACTERIZATION PLOTS

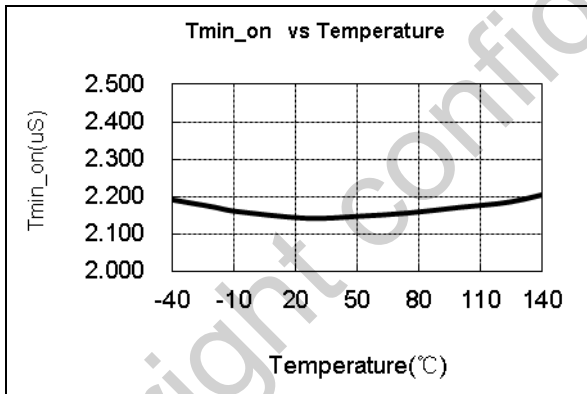
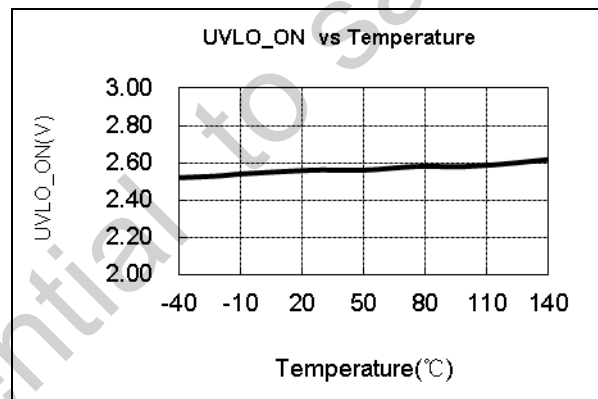
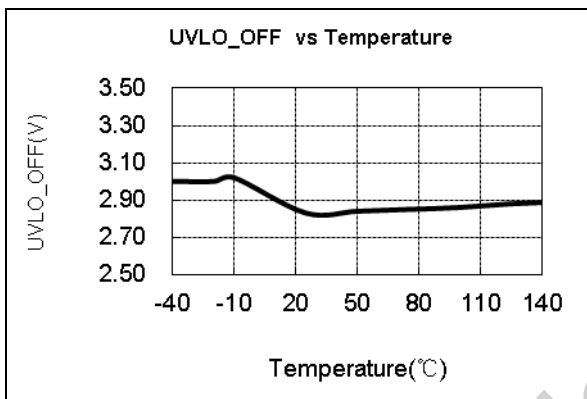

### Operation Description

OB2004Ax is a high performance and versatile synchronous rectifier. It can emulate the behavior of Schottky diode rectifier which directly reduces power dissipation of the traditional rectifiers and indirectly reduces primary-side loss due to compounding of efficiency gains.

#### Startup and under voltage lockout (UVLO)

Whether OB2004Ax can operate normally or not depends on UVLO function implemented on chip and system output voltage. When power system is plugged in, VDD cap is charged from transformer secondary winding. When VDD rises above UVLO(off), the IC wakes up from under voltage lock out state and monitors the system output voltage through Vin pin. OB2004Ax will output SR gate based on correct timing after VDD rises above 3.0V(typical). Refer to the following timing diagram.

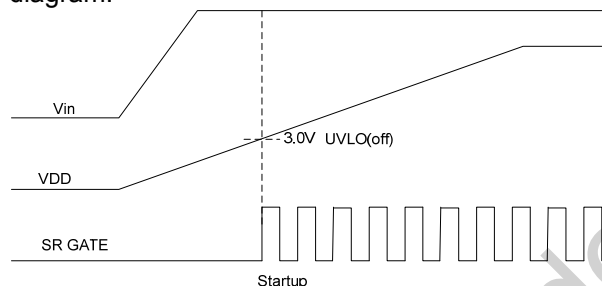

Fig.1 System start up timing diagram

With enough high Vin, OB2004Ax would be powered from VDD and system output (Vin), which can lead to better system efficiency. When VDD drops below UVLO(on), SR would be disable. Refer to the following timing diagram. For system reliability, the SR gate would be pulled low when VDD is lower than 2.4V (typical). Refer to the following timing diagram.

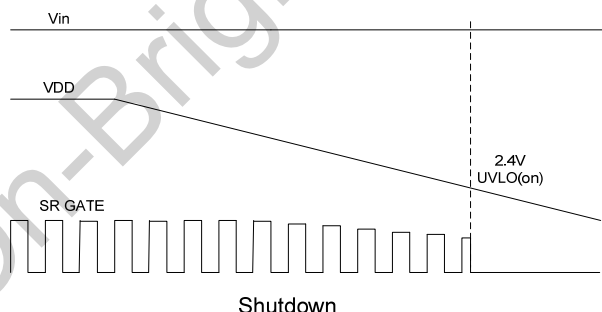

Fig.2 System shut down timing diagram

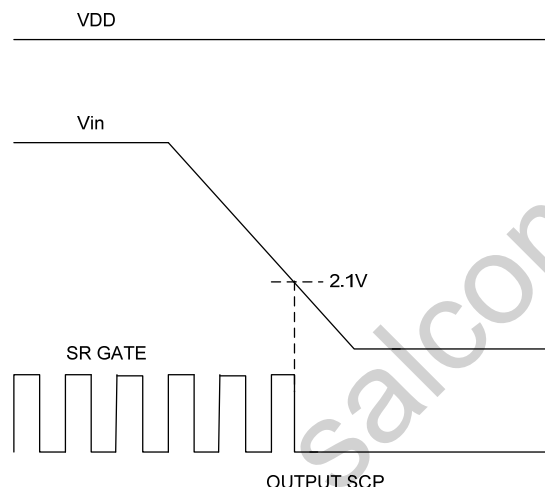

Fig.3 System output SCP timing diagram

Additionally, there is a pull down on-chip 15Kohm resistor to avoid the misconducting by VDrain pulse coupling. Besides, a hysteresis window between UVLO(off) and UVLO(on) makes system work reliably.

#### Synchronization rectifier

OB2004Ax controls the turn-on and turn-off of synchronization rectifier MOSFET (SR MOSFET) by detection of drain-source voltage and prediction control. When demagnetization of transformer starts, the secondary-side current will flow through the body diode of SR MOSFET and the voltage at the drain will drop to below -200mV (typical). As soon as OB2004Ax detects this negative voltage, the driver voltage is pulled high to turn on the SR MOSFET after variable delay time depending on input line voltage and loading condition, refer to Fig.4. This variable delay time can improve system immunity to noise.

After the SR MOSFET is turned on, the drain voltage of SR MOSFET begins to rise based on its Rds(on) and secondary-side current. The drain voltage becomes higher with demagnetization going on. When the drain voltage rises above -1mV, the driver voltage will be pulled down to ground very quickly, refer to Fig.4

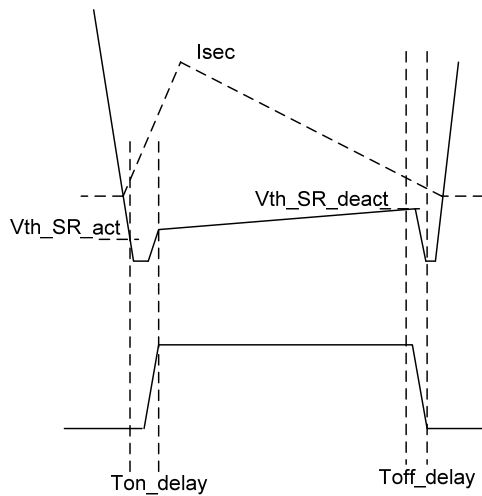

Fig.4 SR MOSFET turn-on and turn-off timing

### Prediction control in CCM

When system works in CCM mode, drain voltage can not rise above -1mV when primary side turns on. In this case the property prediction algorithm implemented in OB2004Ax turns off the SR. OB2004Ax would detect the demagnetization time of current cycle and use this information to turn off SR in next cycle. For stable CCM, there is little variation between consecutive demagnetization phase, so the next cycle SR can be turn off predictively with pre-set prediction ratio, such as 66%. This means the next SR turn-on would last 66% of current demagnetization time before turn off. However when sub-harmonic switching happens, there is risk of short-circuit of transformer if both primary side and secondary side switch controllers are in turn-on phase. To avoid this risk, OB2004Ax would detect the primary side turn on time. If the primary side turn on time of current cycle is 500ns (typical) longer than the previous cycle, the pre-set prediction ratio would be changed from 66% to 15% so that the SR turn-on time is significantly reduced to avoid the risk of short-circuit of transformer. Fig.5 and Fig.6 illustrates the control scheme. In the next consecutive cycles, the SR on-time will be gradually increased that improve the efficiency.

In addition, a adaptive dead time control is implemented (described in next section). It regulates the time period (dead time) between the SR tune off instance and turn on instance of the

primary side to be 0.8uS in stable CCM operation to further improve the efficiency while ensure the safe operation.

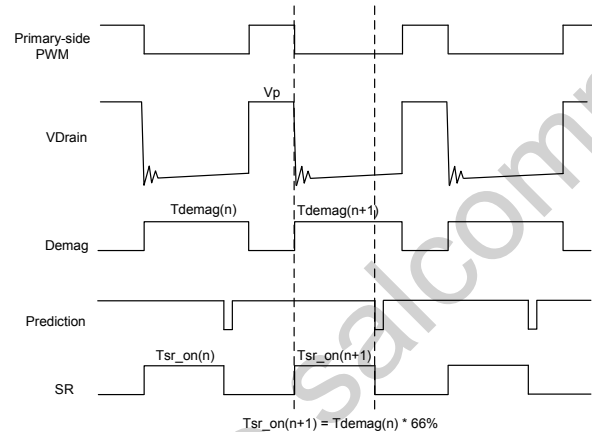

Fig.5 Prediction in stable CCM

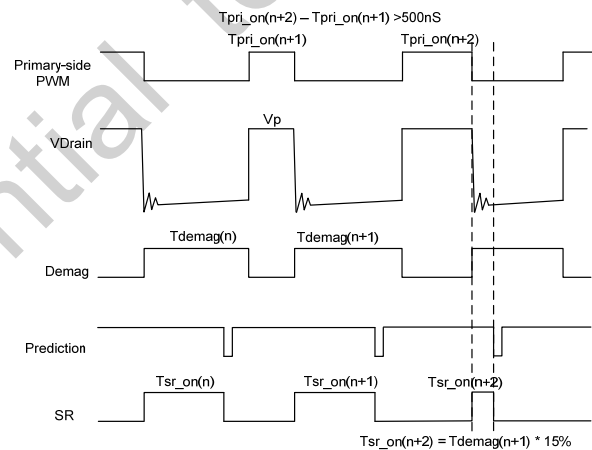

Fig.6 Prediction in CCM with sub-harmonic

### Dead time control

For efficiency and thermal issue, the demagnetization current flowing through SR MOSFET body diode after SR turn off should be as small as possible, i.e the dead time between SR turn off and demagnetization ending is as short as possible. But when SR MOSFET Rdsn is too small or interference riding on Vds, SR maybe turn off prematurely. In this case, an adaptive dead time control algorithm used in OB2004Ax can correct the dead time to 0.8uS (typical) for good efficiency and thermal performance.



**PACKAGE MECHANICAL DATA**  
**SOP8 PACKAGE OUTLINE DIMENSIONS**

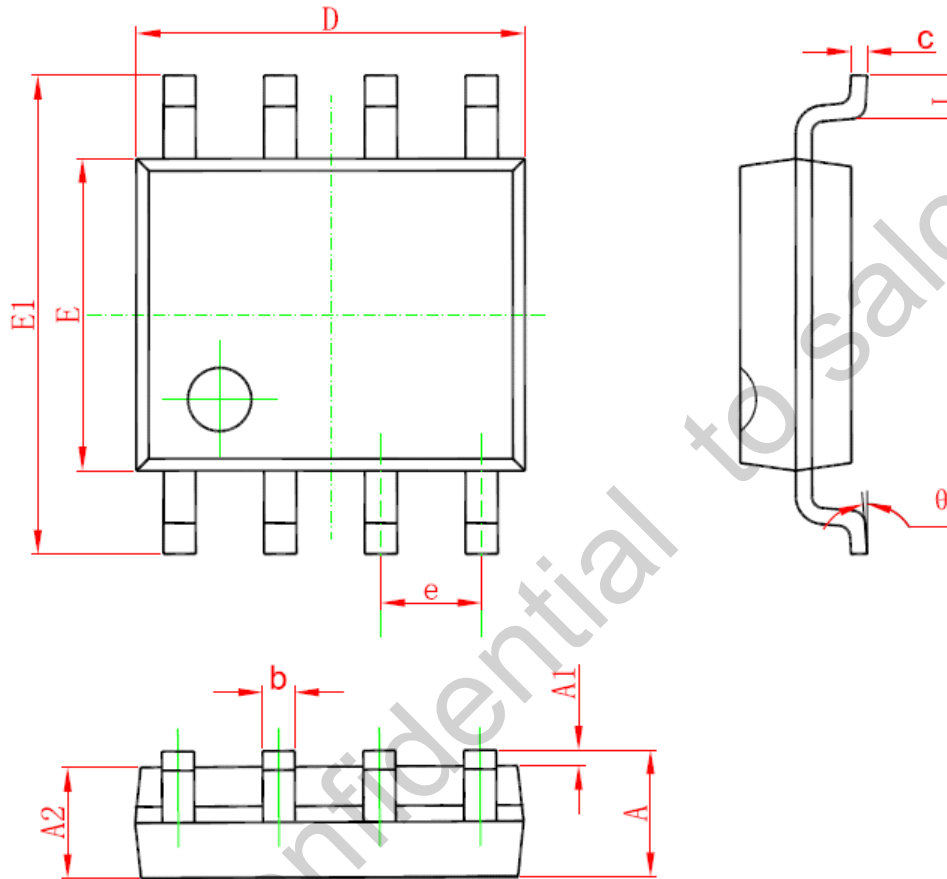

Symbol	Dimensions In Millimeters		Dimensions In Inches	
	Min	Max	Min	Max
A	1.350	1.750	0.053	0.069
A1	0.050	0.250	0.002	0.010
A2	1.250	1.650	0.049	0.065
b	0.310	0.510	0.012	0.020
c	0.100	0.250	0.004	0.010
D	4.700	5.150	0.185	0.203
E	3.800	4.000	0.150	0.157
E1	5.800	6.200	0.228	0.244
e	1.270 (BSC)		0.050 (BSC)	
L	0.400	1.270	0.016	0.050
theta	0°	8°	0°	8°

## **IMPORTANT NOTICE**

### **RIGHT TO MAKE CHANGES**

On-Bright Electronics Corp. reserves the right to make corrections, modifications, enhancements, improvements and other changes to its products and services at any time and to discontinue any product or service without notice. Customers should obtain the latest relevant information before placing orders and should verify that such information is current and complete.

### **WARRANTY INFORMATION**

On-Bright Electronics Corp. warrants performance of its hardware products to the specifications applicable at the time of sale in accordance with its standard warranty. Testing and other quality control techniques are used to the extent it deems necessary to support this warranty. Except where mandated by government requirements, testing of all parameters of each product is not necessarily performed.

On-Bright Electronics Corp. assumes no liability for application assistance or customer product design. Customers are responsible for their products and applications using On-Bright's components, data sheet and application notes. To minimize the risks associated with customer products and applications, customers should provide adequate design and operating safeguards.

### **LIFE SUPPORT**

On-Bright Electronics Corp.'s products are not designed to be used as components in devices intended to support or sustain human life. On-bright Electronics Corp. will not be held liable for any damages or claims resulting from the use of its products in medical applications.

### **MILITARY**

On-Bright Electronics Corp.'s products are not designed for use in military applications. On-Bright Electronics Corp. will not be held liable for any damages or claims resulting from the use of its products in military applications.

## X-ON Electronics

Largest Supplier of Electrical and Electronic Components

*Click to view similar products for [Switching Voltage Regulators](#) category:*

*Click to view products by [On-Bright](#) manufacturer:*

Other Similar products are found below :

[FAN53610AUC33X](#) [FAN53611AUC123X](#) [EN6310QA](#) [160215](#) [R3](#) [KE177614](#) [MPQ4423GQ-AEC1-Z](#) [FAN53611AUC12X](#) [MAX809TTR](#)  
[NCV891234MW50R2G](#) [AST1S31PUR](#) [NCP81103MNTXG](#) [NCP81203PMNTXG](#) [NCP81208MNTXG](#) [PCA9412AUKZ](#)  
[NCP81109GMNTXG](#) [NCP81109JMNTXG](#) [MP2161AGJ-Z](#) [NCP81241MNTXG](#) [MPQ4481GU-AEC1-P](#) [MP8756GD-P](#) [MPQ2171GJ-P](#)  
[MPQ2171GJ-AEC1-P](#) [MP2171GJ-P](#) [NCV1077CSTBT3G](#) [MP28160GC-Z](#) [MPM3509GQVE-AEC1-P](#) [XDPE132G5CG000XUMA1](#)  
[MP5461GC-P](#) [IR3888AMTRPBFAUMA1](#) [MPQ4409GQBE-AEC1-P](#) [S-19903DA-A8T1U7](#) [S-19903CA-A6T8U7](#) [S-19903CA-S8T1U7](#) [S-](#)  
[19902BA-A6T8U7](#) [S-19902CA-A6T8U7](#) [AP7361EA-SPR-13](#) [AP7361EA-33DR-13](#) [S-19902AA-A6T8U7](#) [S-19903AA-A6T8U7](#) [S-](#)  
[19902AA-S8T1U7](#) [S-19902BA-A8T1U7](#) [AU8310](#) [LMR36503R5RPER](#) [LMR36503RFRPER](#) [XC9110C301MR-G](#) [XC9141A50CMR-G](#)  
[XCL206F083CR-G](#) [XCL210A111GR-G](#) [LTM4663EV#PBF](#)