

## GENERAL DESCRIPTION

OB2632 is a highly integrated current mode PWM control IC with high voltage startup, optimized for high performance, low standby power consumption and wide output voltage range PD adapter solutions, together with PD secondary controller, such as OB2612. The controller is as well compatible with cost effective offline flyback converter applications covering a wide output range.

At full loading, the IC operates in fixed frequency mode. When the loading goes low, it operates in Green mode with valley switching for high power conversion efficiency. When the load is very small, the IC operates in 'Extended Burst Mode' to minimize the standby power loss. As a result, high conversion efficiency can be achieved in the whole loading range.

High voltage startup is implemented in OB2632CP, which features with short startup time and low standby power loss.

VCC low startup current and low operating current contribute to a reliable power on startup and low standby design with OB2632MP.

OB2632 offers complete protection coverage including cycle-by-cycle current limiting (OCP), over load protection (OLP), over temperature protection (OTP), output short(SCP), output and VDD over voltage protection. Excellent EMI performance is achieved with On-Bright proprietary frequency shuffling technique.

The tone energy at below 23KHz is minimized to avoid audio noise during operation.

OB2632 is offered in SOP8 or SOT23-6 package.

## APPLICATIONS

Offline AC/DC flyback converter for

- PD adapters
- Wide output range adapters

## FEATURES

- Multi-Mode Operation
  - 125KHz max frequency mode @ Peak Load
  - 65KHz or 45KHz fixed frequency mode @ Full Load
  - Valley switching operation @ Green mode
  - Burst Mode @ Light Load & No Load
- Adaptive loop gain compensation with lvpv current detection
- Ultra low operating current at light/no load
- Internal OCP compensation for universal line voltage
- Extended burst mode control for improved efficiency and low standby power
- Power on soft start reducing MOSFET Vds stress
- Frequency shuffling for EMI
- Audio noise free operation
- High voltage startup integrating intelligent brownout detection, AC off detection with X-CAP discharge function(OB2632CP only)
- Comprehensive protection coverage
  - VDD under voltage lockout with hysteresis (UVLO)
  - Cycle-by-cycle over current protection (OCP) with auto-recovery
  - Overload protection (OLP) with auto-recovery
  - Over temperature protection (OTP) with latch shut down
  - VDD over voltage protection with latch shut down
  - Output over voltage protection with latch shut down
  - Output short protection (SCP) with auto-recovery
  - Brownout protection with auto-recovery (OB2632CP only)
  - Output diode short protection with auto-recovery

**TYPICAL APPLICATION**

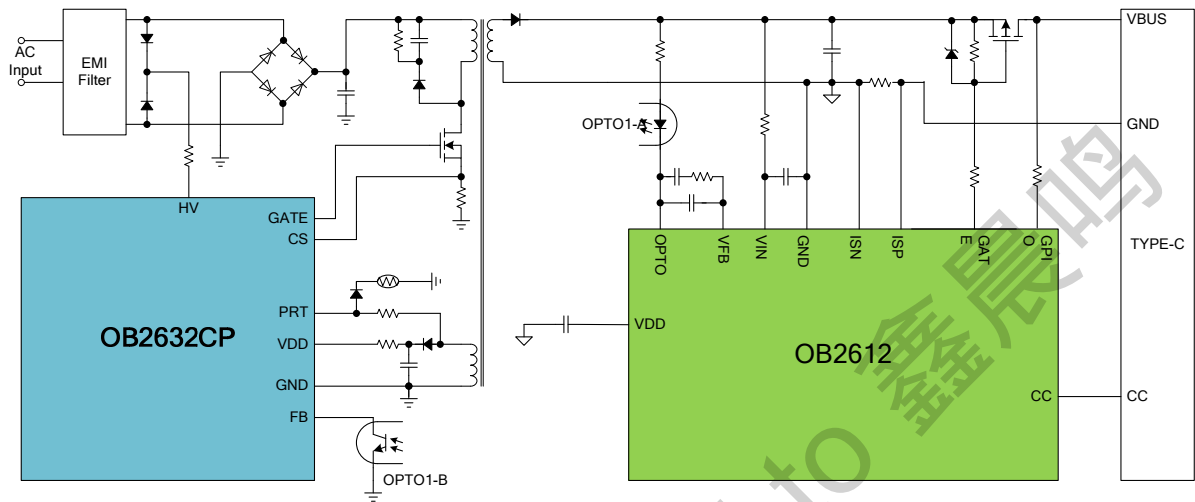

OB2632CP Typical Application

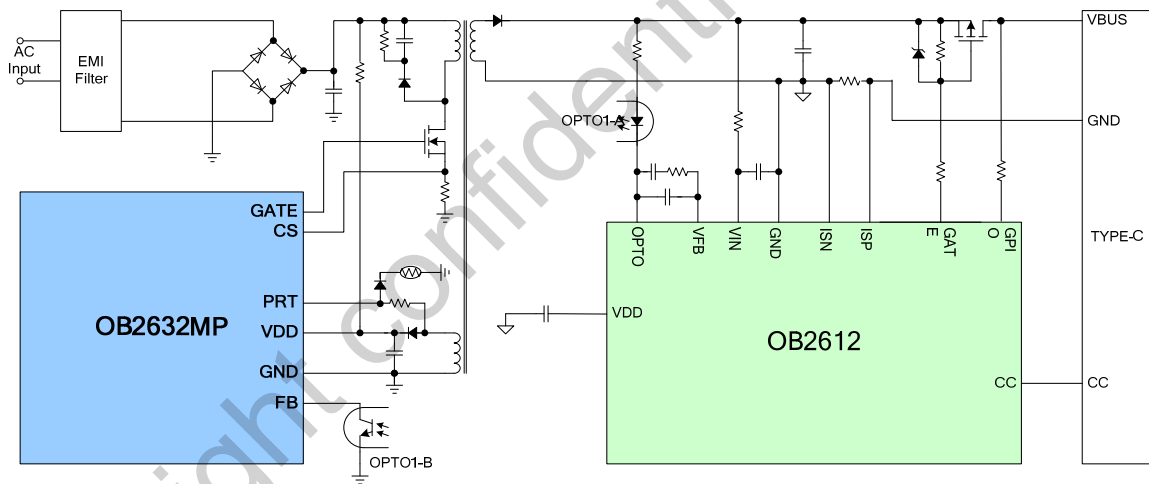

OB2632MP Typical Application

## GENERAL INFORMATION

### Pin Configuration

The OB2632 is offered in SOP8 and SOT23-6 package, shown as below.

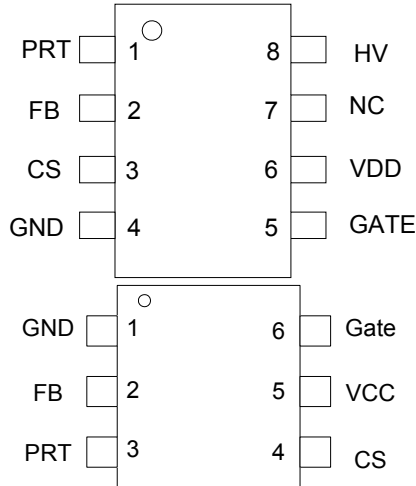

### Package Dissipation Rating

Package	R $\theta$ JA(°C/W)
SOP8	90
SOT23-6	200

### Absolute Maximum Ratings

Parameter	Value
VDD DC Supply Voltage	54V
High-Voltage Pin, HV (OB2632CP only)	-0.3 to 500 V
FB Input Voltage	-0.3 to 7V
CS Input Voltage	-0.3 to 7V
PRT Input Voltage	-0.3 to 7V
Min/Max Operating Junction Temperature T <sub>J</sub>	-40 to 150 °C
Operating Ambient Temperature T <sub>A</sub>	-40 to 85 °C
Min/Max Storage Temperature T <sub>stg</sub>	-55 to 150 °C
Lead Temperature (Soldering, 10secs)	260 °C

### Ordering Information

Part Number	Description
OB2632CP	SOP8, Halogen-free, Tube
OB2632CPA	SOP8, Halogen-free, T&R
OB2632MP	SOT23-6, Halogen-free, T&R

### Recommended Operating Condition

Symbol	Parameter	Range
VDD	VCC Supply Voltage	12 to 50V

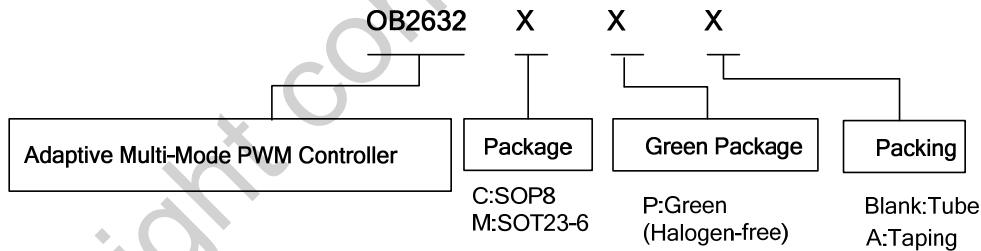

### Marking Information



Y:Year Code  
 WW:Week Code(01-52)  
 ZZZ:Lot Code  
 C:SOP8 Package  
 P:Green Package(Halogen-free)  
 S:Internal Code(Optional)

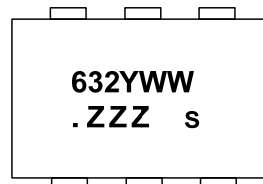

Y:Year Code  
 WW:Week Code(01-52)  
 ZZZ: Lot code  
 S: Internal code

## TERMINAL ASSIGNMENTS

### For OB2632CP

Pin NO.	Pin Name	I/O	Description
1	PRT	I	Multiple functions pin. Connecting a NTC resistor to ground for OTP detection. Connecting a resistor from Vaux can adjust IOVP/ISCP trigger current and detect transformer core demagnetization. If both OTP and OVP/SCP are needed, a diode should be connected between PRT pin and the NTC resistor.
2	FB	I	Feedback input pin. The PWM duty cycle is determined by voltage level into this pin and the current-sense signal at CS pin
3	CS	I	Current sense input
4	GND	P	Ground
5	Gate	O	Totem-pole gate driver output for power Mosfet
6	VDD	P	Power Supply
7	NC		
8	HV	P	Connected to the line input via resistors and diodes for startup and x-cap discharge, this PIN allows the brownout detection as well.

### For OB2632MP

Pin NO.	Pin Name	I/O	Description
1	GND	P	Ground
2	FB	I	Feedback input pin. The PWM duty cycle is determined by voltage level into this pin and the current-sense signal at CS pin
3	PRT	I	Multiple functions pin. Connecting a NTC resistor to ground for OTP detection. Connecting a resistor from Vaux can adjust IOVP/ISCP trigger current and detect transformer core demagnetization. If both OTP and OVP/SCP are needed, a diode should be connected between PRT pin and the NTC resistor.
4	CS	I	Current sense input
5	VDD	P	Power Supply
6	Gate	O	Totem-pole gate driver output for power Mosfet

**BLOCK DIAGRAM**

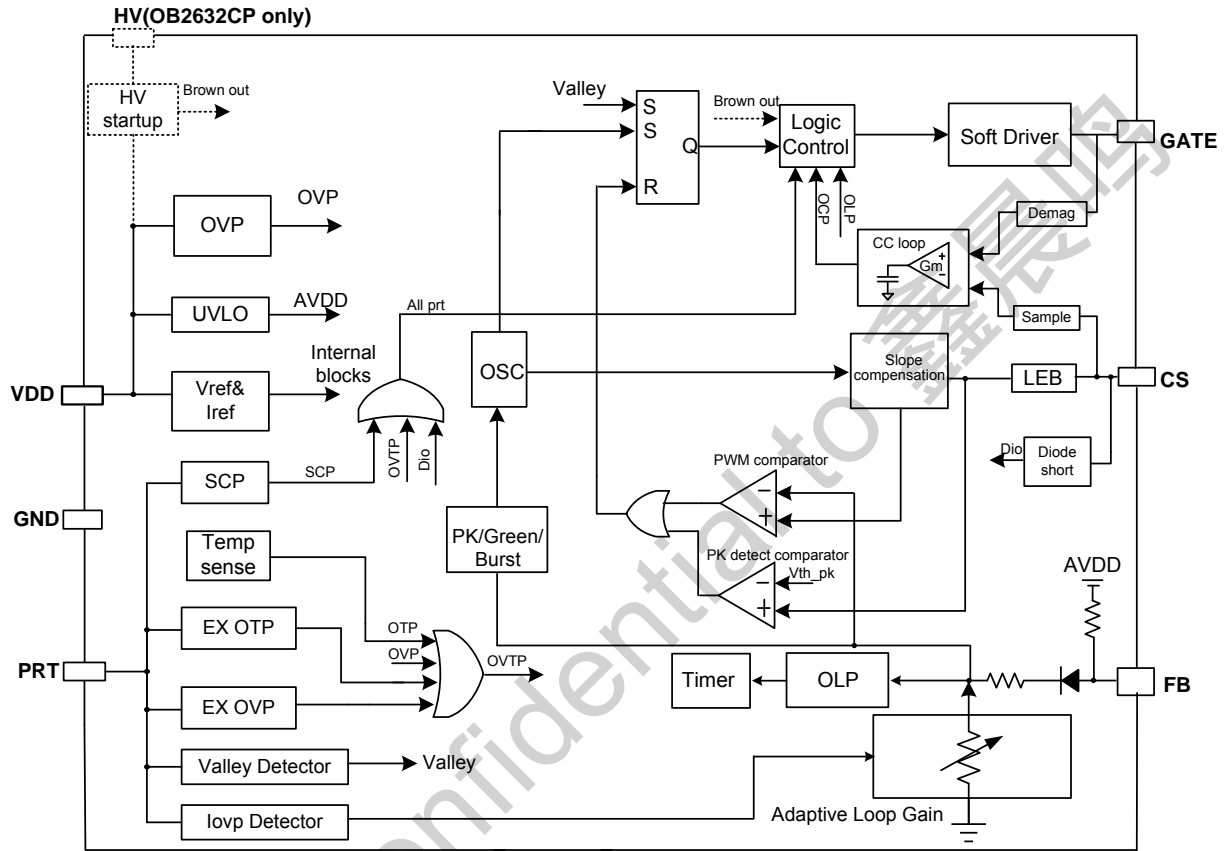

## ELECTRICAL CHARACTERISTICS

( $T_A = 25^\circ\text{C}$ ,  $V_{DD}=18\text{V}$ , unless otherwise noted)

Symbol	Parameter	Test Conditions	Min	Typ.	Max	Unit
<b>HV Startup (OB2632CP only)</b>						
IHV1	Supply current from HV pin @ $V_{DD}>1\text{V}$	$V_{DD}=2\text{V}$ , $HV=100\text{V}$	1	2	3.5	mA
IHV2	Supply current from HV pin @ $V_{DD}<1\text{V}$	$V_{DD}=0.5\text{V}$ , $HV=100\text{V}$	0.3	0.57	0.85	mA
leakage	HV pin leakage current after startup	$V_{DD}=18\text{V}$ , $HV=500\text{V}$		5	10	$\mu\text{A}$
<b>Supply Voltage (VDD)</b>						
Istartup	VDD Start up Current	$V_{DD}=UVLO(\text{OFF})-1\text{V}$ , measure leakage current into VDD		5	20	$\mu\text{A}$
Iop_VDD	Normal Operation Current	$V_{FB}=3\text{V}$ , $CL=1\text{nF}$		2.8	3.3	mA
Iop_VDD_Burst	Burst Operation Current	$V_{FB}=0.5\text{V}$ , $CL=1\text{nF}$		0.44	0.48	mA
UVLO(ON)	VDD Under Voltage Lockout Enter		6.7	7.2	7.7	V
UVLO(OFF)	VDD Under Voltage Lockout Exit (Recovery)		15.5	16.5	17.5	V
Vpull-up	Pull-up PMOS active			10		V
OVP	Over voltage protection voltage	$FB=3\text{V}$ Ramp up VDD until gate clock is off	51	52.5	54	V
Vth_latch	Latch release voltage			4.8		V
$T_{D\_recovery}$ (OB2632CP only)	Restart time for auto-recovery protection			1.4		s
<b>Feedback Input Section(FB Pin)</b>						
$V_{FB\_Open}$	$V_{FB}$ Open Loop Voltage			5.1		V
Avcs	PWM input gain $\Delta V_{FB}/\Delta V_{CS}$	$I_{ovp} \geq 170\mu\text{A}$ with Hysteresis		2.75		V/V
		$95\mu\text{A} \leq I_{ovp} \leq 150\mu\text{A}$ with Hysteresis		3.5		V/V
		$I_{ovp} \leq 85\mu\text{A}$ with Hysteresis		4.5		V/V
Maximum duty cycle	Max duty cycle @ $V_{DD}=14\text{V}$ , $V_{FB}=3\text{V}$ , $V_{CS}=0.3\text{V}$	$I_{ovp} > 95\mu\text{A}$		80		%
Vref_rising	The threshold enter rising frequency mode	$I_{ovp} > 243\mu\text{A}$		3.5		V
Vref_green	The threshold enter green mode			1.85		V
Vref_burst_H	The threshold exit burst mode			1.2		V
Vref_burst_L	The threshold enter burst mode			1.1		V
$I_{FB\_Short}$	FB pin short circuit current	Short FB pin to GND and measure current		210		$\mu\text{A}$
$V_{TH\_Openloop}$	The open loop FB Threshold			4.5		V

	Voltage						
T <sub>D_</sub> Openloop	The open loop protection debounce Time			40			ms
Z <sub>FB_IN</sub>	Input Impedance			30			KΩ
<b>Current Sense Input(CS Pin)</b>							
SST_CS	Soft start time of CS threshold			4			ms
T <sub>blanking</sub>	Leading edge blanking time			300			ns
T <sub>D_</sub> OC	Over Current Detection and Control Delay	From Over Current Occurs till the gate driver output starts to turn off		90			ns
Vref_PK	Internal Current Limiting Threshold Voltage with zero duty cycle		0.48	0.50	0.52		V
Vref_PK_clamp	CS voltage clamper			0.84			V
Vref_OCP	Internal OCP protection voltage threshold		0.287	0.296	0.305		V
Td_cs_pk_ADJ	The delay time from PWM off to CS peak clamping adjustment start point			2.5			us
I <sub>OCP_ADJ</sub>	Output current from CS pin when PWM turns off		92	100	108		uA
T <sub>D_</sub> OCP	OCP Debounce Time			60			ms
<b>Oscillator</b>							
F <sub>OSC_nom</sub>	Normal Fixed Oscillation Frequency of high output voltage	VDD=15V, FB=3V, I <sub>ovp</sub> >95uA	60	65	70		KHz
F <sub>osc_low</sub>	Normal Fixed Oscillation Frequency of low output voltage	I <sub>OVP</sub> <85uA		45			KHz
F <sub>osc_PK</sub>	Peak frequency	VDD=15V,FB=4.5V, I <sub>ovp</sub> >243uA		125			KHz
Δf <sub>OSC</sub>	Frequency jittering			+/-7			%
F <sub>shuffling</sub>	Shuffling frequency			240			Hz
Δf <sub>Temp</sub>	Frequency Temperature Stability			1			%
Δf <sub>VDD</sub>	Frequency Voltage Stability			1			%
F <sub>Burst</sub>	Burst Mode Switch Frequency			23			KHz
<b>Gate driver</b>							
VOL	Output low level @ VDD=15V, I <sub>o</sub> =20mA					1	V
VOH	Output high level @ VDD=15V, I <sub>o</sub> =20mA		8				V
V <sub>clamping</sub>	Output clamp voltage			11.5			V
T <sub>r</sub>	Output rising time 1.2V ~ 10.8V @ CL=1000pF			140			ns
T <sub>f</sub>	Output falling time 10.8V ~ 1.2V @ CL=1000pF			55			ns

Brownout protection(OB2632CP only)							
Vth_bo_L	Threshold voltage for Brownout	RHV=200 KΩ	63	70	77	VAC	
Vth_bo_H	Threshold voltage for Brownout release	RHV=200 KΩ	70	77	85	VAC	
Td_brownout	Brownout debounce time		27	32	37	ms	
PRT pin							
Ibias	Output bias current expect during OVP detection			30		uA	
IRT	Output current for external OTP detection		114	120	126	uA	
Vref_OTP	Threshold voltage for external OTP		1.14	1.2	1.26	V	
Td_ex_OTP	EX OTP debounce time			60		Cycles	
Ioutput_ovp	Current threshold for adjustable output OVP		340	360	380	uA	
Td_output_ovp	Output OVP debounce time			8		Cycles	
Tsamp_OVP	The time from Gate off to OVP detecting turn-off point	FB=2.5V		2.5		us	
		FB=1.5V		1.8		us	
Iscp	SCP threshold	T<15ms after startup		23		uA	
Td_scp	SCP debounce time			8		Cycles	
On Chip OTP							
OTP Level				155		°C	
OTP exit				125		°C	



## CHARACTERIZATION PLOTS

VDD = 18V, TA = 25°C condition applies if not otherwise noted.

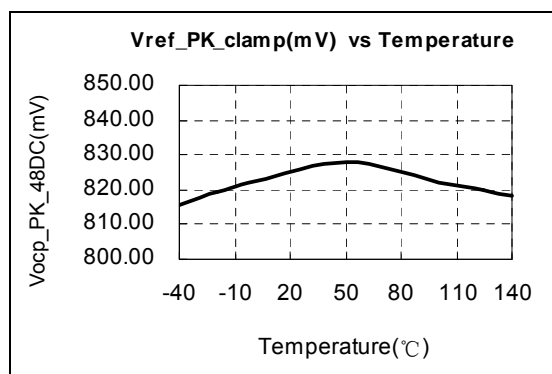
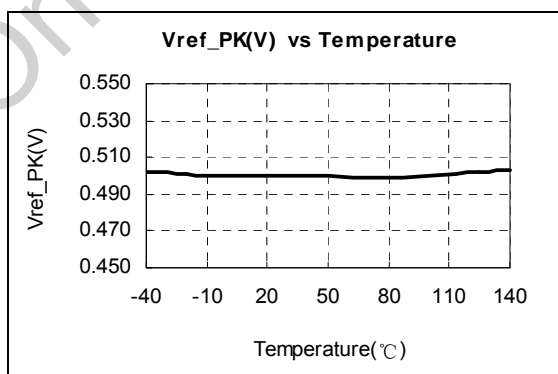
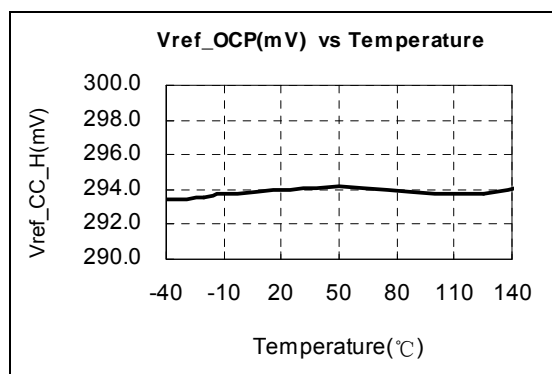
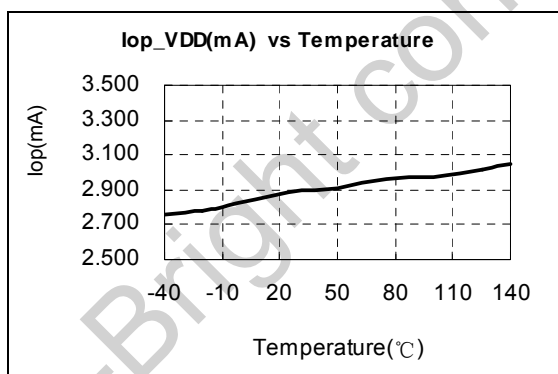
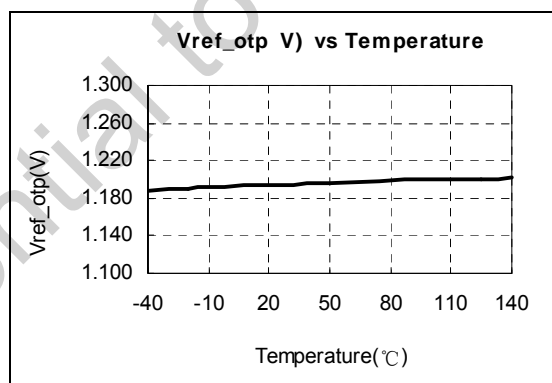
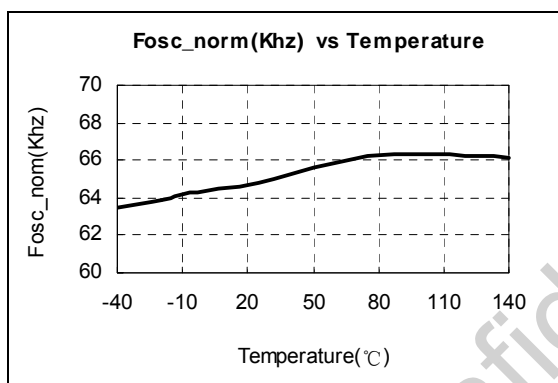
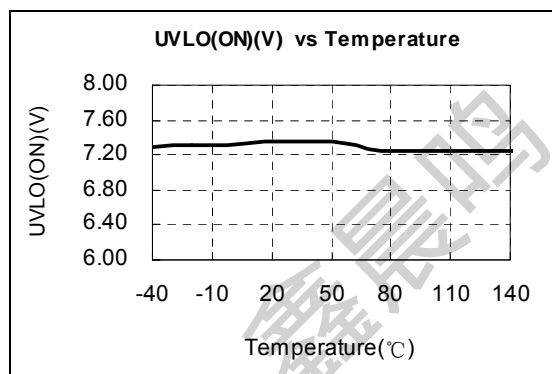
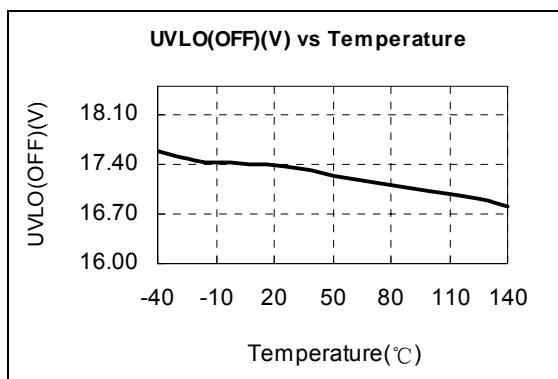

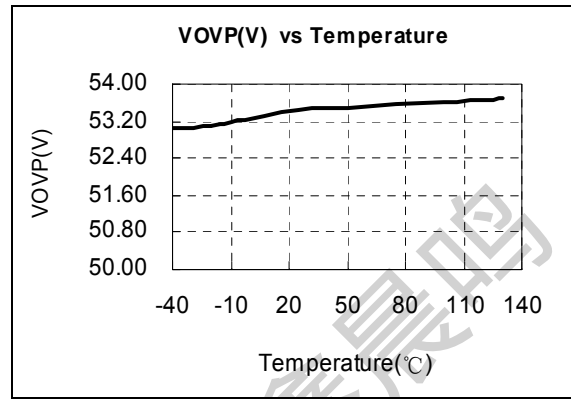
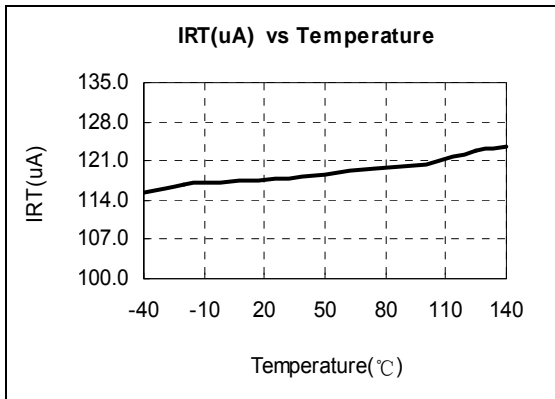

## OPERATION DESCRIPTION

OB2632 is a highly integrated current mode PWM control IC with high voltage startup, optimized for high performance, low standby power consumption and wide output voltage range PD adapter solutions, together with PD secondary controller, such as OB2612. The controller is as well compatible with cost effective offline flyback converter applications covering a wide output range. The 'Extended burst mode' control greatly reduces the standby power consumption and helps the design easily to meet the international power conservation requirements.

### Internal High Voltage Startup and Under Voltage Lockout (UVLO) (OB2632CP only)

OB2632 integrates HV startup circuit, and provides about 2mA current to charge VDD pin during power on state from HV pin. When VDD voltage is higher than UVLO(OFF), the charge current is switched off. At this moment, the VDD capacitor provides current to OB2632 until the auxiliary winding of the main transformer starts to provide the operation current.

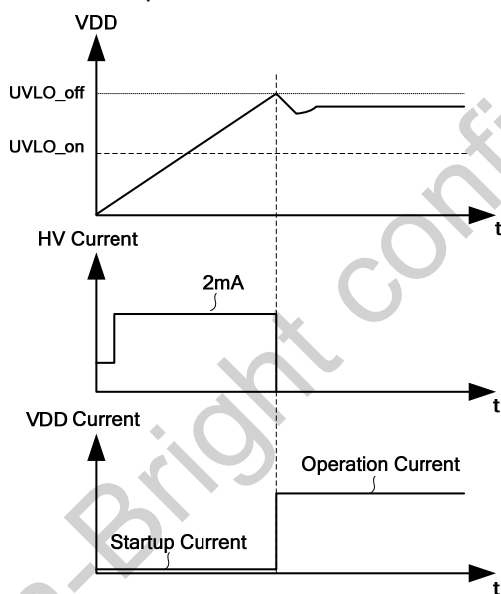

Fig1 Startup current timing

### Startup Current and Start up Control (OB2632MP only)

Startup current of OB2632 is designed to be very low so that VCC could be charged up above UVLO threshold level and device starts up quickly. A large value startup resistor can therefore be used to minimize the power loss yet achieve a reliable startup in application.

### Operating Current

The typical operating current of OB2632 is 2.8mA. Good efficiency is achieved with this low operating

current together with the 'Extended burst mode' control features.

### Soft Start

OB2632 features an internal 4ms (typical) soft start to soften the electrical stress occurring in the power supply during startup. It is activated during the power on sequence. As soon as VDD reaches UVLO(OFF), the CS peak voltage is gradually increased from 0V to the maximum level. Every restart up begins with a soft start.

### Adaptive Loop Gain Compensation

With On-Bright proprietary technology, an adaptive loop compensation is implemented to ensure the system loop stability for wide output voltage range according to loup current detection.

### Frequency shuffling for EMI improvement

The frequency shuffling (switching frequency modulation) is implemented in OB2632. The oscillation frequency is modulated so that the tone energy is spread out. The spread spectrum minimizes the conduction band EMI and therefore eases the system design.

### Extended Burst Mode Operation

At light load or no load condition, most of the power dissipation in a switching mode power supply is from switching loss of the MOSFET, the core loss of the transformer and the loss of the snubber circuit. The magnitude of power loss is in proportion to the switching frequency. Lower switching frequency leads to the reduction on the power loss and thus conserves the energy.

The switching frequency is internally adjusted at no load or light load condition. The switch frequency reduces at light/no load condition to improve the conversion efficiency. At light load or no load condition, the FB input drops below Vref\_burst\_L (the threshold enter burst mode) and device enters Burst Mode control. The Gate drive output switches when FB input rises back to Vref\_burst\_H (the threshold exit burst mode). Otherwise the gate drive remains at off state to minimize the switching loss and reduces the standby power consumption to the greatest extend.

### Oscillator Operation

During the full load power operation, OB2632 operates at a 65KHz (typical) fixed frequency of high output voltage (I<sub>ovp</sub>>95uA), and it operates at a 45KHz (typical) fixed frequency of low output voltage (I<sub>ovp</sub><85uA). The efficiency and system cost is controlled at an optimal level. A peak power mode is implemented based on On-Bright proprietary technology to supply a peak current

output requirement ( $I_{OVP} > 243\mu A$ ). In peak power mode, frequency is increased from 65KHz (typical) to 125KHz (typical).

At light load, OB2632 enters the light load mode, where the output current is reduced. The switching losses are reduced by lowering the switching frequency.

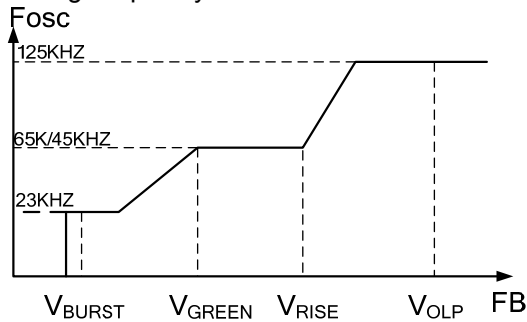

Fig 2 Frequency vs Feedback voltage

### Current Sensing and Leading Edge Blanking

Cycle-by-Cycle current limiting is offered in OB2632 current mode PWM control. The switch current is detected by a sense resistor into the CS pin. An internal leading edge blanking circuit chops off the sensed voltage spike at initial internal power MOSFET on state due to snubber diode reverse recovery and surge gate current of power MOSFET. The current limiting comparator is disabled and cannot turn off the power MOSFET during the blanking period. The PWM duty cycle is determined by the current sense voltage and the FB voltage.

### Internal Synchronized Slope Compensation

Built-in slope compensation circuit adds voltage ramp into the current sense input voltage for PWM generation. This greatly improves the close loop stability at CCM and prevents the sub-harmonic oscillation and thus reduces the output ripple voltage.

### Demagnetization Detection

The transformer core demagnetization is detected by monitoring the voltage activity on the auxiliary windings through PRT pin. This voltage features a flyback polarity. After the on time (determined by the CS voltage and FB voltage), the switch is off and the flyback stroke starts. After the flyback stroke, the drain voltage shows an oscillation with a frequency of approximately  $1/2\pi\sqrt{L_p C_d}$ , where  $L_p$  is the primary self inductance of primary winding of the transformer and  $C_d$  is the capacitance on the drain node.

The typical detection level is fixed at 85mV(typical) at the PRT pin. Demagnetization is recognized by detection of a possible "valley" when the voltage at PRT is below 85mV in falling edge.

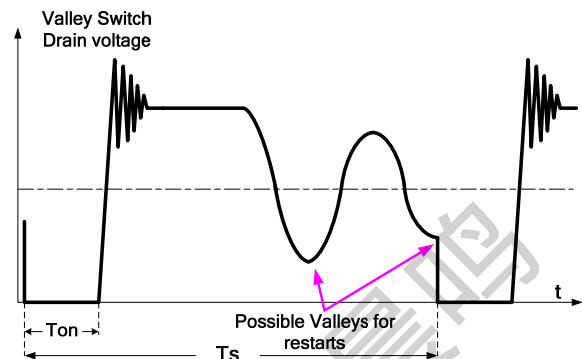

Fig3 Valley detection

### Dual Function of External OTP and Output OVP/SCP

On-Bright proprietary dual function of external OTP and output OVP provides feasible and accurate detection of external OTP through NTC resistor and output OVP. The dual function is realized through time-division technology as shown in the figure 4.

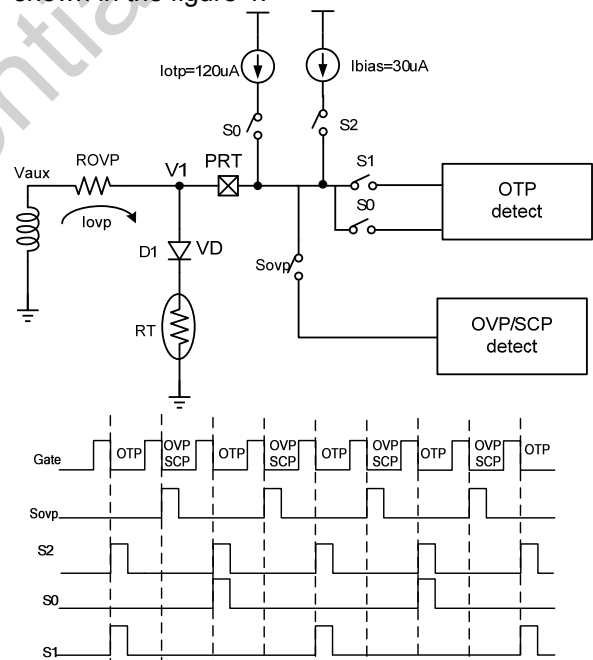

Fig4 PRT Pin protection timing

There is a 30uA(typical) bias current outflow when  $S_2=1$ , that's  $S_0= "1"$  or  $S_1= "1"$ . For external OTP detection, when switch control signal  $S_1= "1"$ , the 30uA (typical) current flows out from PRT pin. When switch control signal  $S_0= "1"$ , another 120uA (typical IRT) current flows out from PRT pin in addition to 30uA.

So the PRT pin voltage  $V_1(s_0)$  at phase  $S_1= "1"$  is:

$$V_1(s_1) = \frac{ROVP \cdot VD + RT \cdot V_{aux} + RT \cdot ROVP \cdot 30\mu A}{ROVP + RT}$$

The PRT pin voltage  $V1(s1)$  at phase  $S0=“1”$  is

$$V1(s0) = \frac{ROVP \cdot VD + RT \cdot Vaux + RT \cdot ROVP(30\mu A + 120\mu A)}{ROVP + RT}$$

$Vaux$  is the auxiliary winding demagnetization voltage.

$VD$  is D1 forward voltage.

$ROVP$  and  $RT$  are shown in fig4.

Voltage difference of  $\Delta V_{otp}$  at phase  $S0$  and  $S1$  phase is

$$\Delta V_{otp} = V1(s0) - V1(s1) = \frac{RT \cdot ROVP}{ROVP + RT} \cdot 120\mu A$$

This voltage difference cancels the effect of D1 diode forward voltage.

When  $\Delta V_{otp} < V_{OTP}$  (1.2V typical), external OTP latch protection is triggered after 60 (typical) PWM cycles debounce.

For output OVP detection, when  $Sovp=“1”$ ,  $I_{ovp}$  is equal to  $(N_{aux}/N_{sec}) \cdot (V_{out} + V_{diode}) / ROVP$ . If  $I_{ovp}$  is larger than 360uA (typical  $I_{out\_ovp}$ ), larger output OVP is triggered. The output OVP voltage is calculated as

$$V_{outovp} = \frac{I_{ovp\_th} \cdot N_{sec} \cdot ROVP}{N_{aux}} - V_{diode}$$

$N_{sec}$  is transformer secondary winding turns,  $N_{aux}$  is transformer auxiliary winding turns,  $V_{diode}$  is the secondary output diode forward voltage.

OVP latch protection is triggered after 8 Gate cycles debounce. By selecting proper  $R_{ovp}$  resistance, output OVP level can be programmed.

For output SCP detection, when  $Sovp=“1”$ ,  $I_{scp}$  is equal to  $(N_{aux}/N_{sec}) \cdot (V_{out} + V_{diode}) / ROVP$ . During the 15ms after the IC startup, if  $I_{scp}$  is less than 23uA (typical  $I_{scp}$ ), SCP is triggered. The output SCP voltage calculation method is the same as output OVP detection.

SCP auto-recovery protection is triggered after 8 Gate cycles debounce. By selecting proper  $R_{ovp}$  resistance, output SCP level can be programmed.

### Protection Controls

Good power supply system reliability is achieved with auto-recovery protection features including OCP, output short protection, Under Voltage Lockout on VDD (UVLO) and peak load protection, and latched shutdown features including Over Temperature Protection (OTP), VDD and output Over Voltage Protection (OVP).

With On-Bright proprietary technology, the OCP is line voltage compensated to achieve constant output OCP limit over the universal input voltage

range and its dependency on primary inductance and frequency is removed.

At overload condition when FB input voltage exceeds power limit threshold value for more than  $Td\_OLP$ , control circuit reacts to shut down the converter. It restarts when VDD voltage drops below UVLO limit. For protection with latched shut down mode, control circuit shuts down (latch) the power MOSFET when an over temperature condition or over voltage condition is detected until VDD drops below 4.8V (typical) (Latch release voltage), and the device enters power on restart-up sequence thereafter.

### Programmable OCP and Peak output Current Controls

In order to meet peak current output requirement, OB2632 sets up two levels output current protection thresholds. The two thresholds correspond to the normal OCP protection and peak power protection respectively. When output current exceeds the OCP threshold for 60ms (typical), OCP protection occurs. The OCP loop ensures the output OCP has a very tight range and is only related with turns ratio and  $R_{sense}$ . The specification for output OCP protection voltage threshold,  $V_{ref\_OCP}$ , is 0.296V (typical).

$$I_{out\_OCP} = \frac{N \cdot V_{ref\_OCP}}{R_{sense}}$$

$N$  is the ratio of transformer primary winding turns to secondary winding turns.

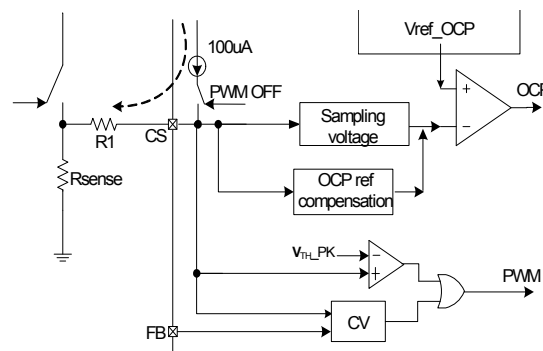

Fig.5 Programmable OCP and PK load protection

OB2632 provides an adaptive cycle-by-cycle OCP compensation method varying with gate on duty cycle in Fig6. The maximum cycle-by-cycle OCP threshold voltage,  $V_{th\_PK}$ , is 0.84V (typical).

At PWM off state, 100uA current flows out of CS pin to generate a voltage through  $R1$  and  $R_{sense}$ . The final CS peak clamping voltage threshold is adjusted by the added voltage.

$$V_{th\_PK\_final} = V_{th\_PK} + 100\mu A \cdot R1$$

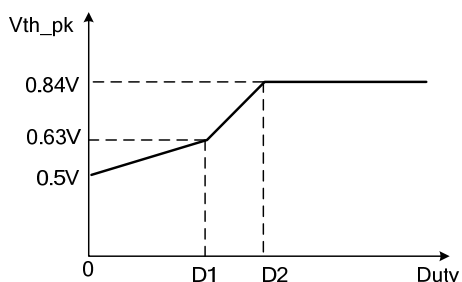

Fig6 Cycle by cycle OCP compensation

**Two level OCP Controls**

In order to meet peak current output requirement under high output level(lov<math>>243\mu A</math>), OB2632 sets up two levels OCP protection thresholds. The two thresholds correspond to the normal OCP protection and peak power protection respectively, and these two threshold values are internally compensated. When primary side inductor current exceeds the OCP threshold, OCP timer will begin counting. After 60ms (typical), OCP protection occurs.

When primary side inductor current exceeds the peak power threshold, over peak power timer will begin counting. After 40ms (typical), peak load protection occurs. OCP and peak power protection are mutually independent and do not affect each.

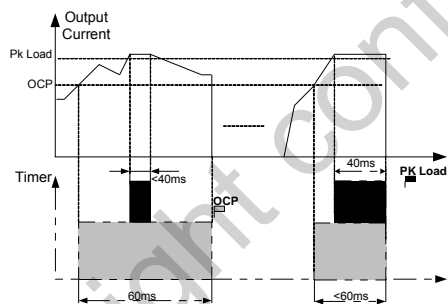
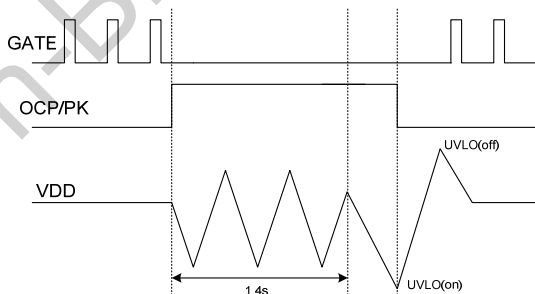

Fig7 Two level OCP Timing



**Fig8 Restart Timing when two level OCP occurs**  
When OCP or peak power protection occurs, no GATE output and VDD begins discharging and charging until the duration is longer than 1.4S . Then VDD begins to drop until to UVLO(on) and later restarts.

**Pin Floating and Short Protection**

OB2632 provides PIN floating protection for all the pins and pin short protection for adjacent pins. In the cases when a pin is floating or two adjacent pins are shorted, Gate switching is disabled.

**Driver**

The power MOSFET is driven by a dedicated gate driver for power switch control. Too weak the gate driver strength results in higher conduction and switch loss of MOSFET while too strong gate driver strength results the compromise of EMI. A good tradeoff is achieved through the built-in totem pole gate design with right output strength and dead time control. The low idle loss and good EMI system design is easier to achieve with this dedicated control scheme.

**Intelligent Brown-in and Brown-out protection, AC off detection with X-CAP discharge function(OB2632CP only)**

A precise brown-in and brown-out detection is implemented by monitoring the rectified AC voltage on HV pin. The final brown in or out threshold is adjusted by the HV resistor in Fig. 9.

$$VHV_{Brown-in/out}(AC) = \frac{(R1 + R2 + 4.2K\Omega) \cdot 70VAC}{200K\Omega + 4.2K\Omega}$$

4.2KΩ is the internal divided programmable resistor of OB2632CP and its variation is within ±10%. 70VAC Brown-out threshold is obtained by set 200KΩ HV resistor.

The HV pin is also used for AC off detection. When AC is off, the AC off state can be detected through HV pin. Then IC will provide a discharge path from HV pin to GND for the X-CAP discharge. OB2632CP meets IEC62368-1 requirements.

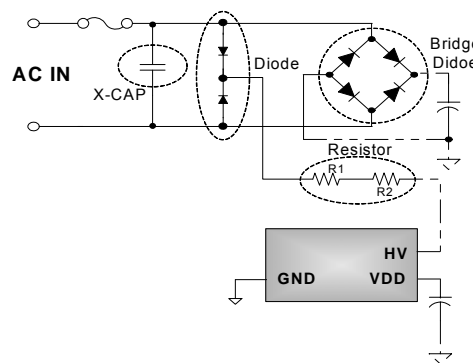
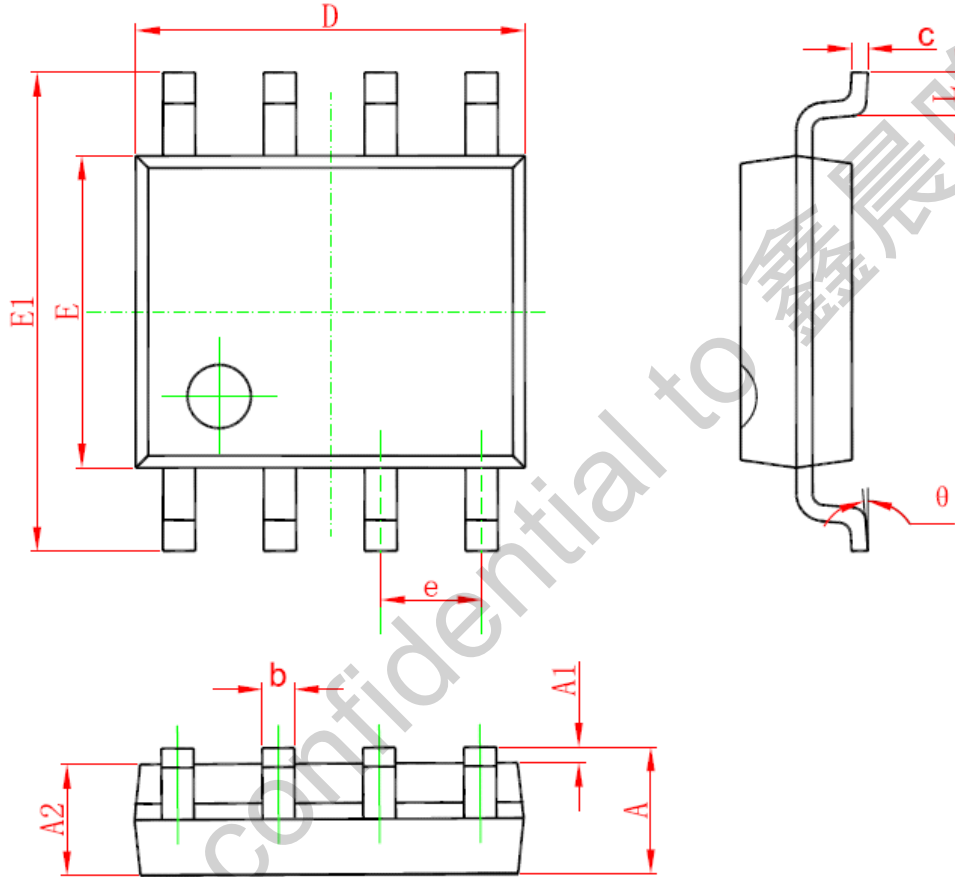

Fig9 X-CAP discharge circuit  
Discharge circuit main components selection

Components	Voltage/Current Stress Range
Bridge Diode	600-1000V, 0.5-20A.
Diode	1000V,1A
Resistor(R1,R2)	10K-120Kohm, 1/4W, SMD1206
X-CAP	0.1uF – 2.04uF

**PACKAGE MECHANICAL DATA**

**SOP8 PACKAGE OUTLINE DIMENSIONS**



Symbol	Dimensions In Millimeters		Dimensions In Inches	
	Min	Max	Min	Max
A	1.350	1.750	0.053	0.069
A1	0.050	0.250	0.002	0.010
A2	1.250	1.650	0.049	0.065
b	0.310	0.510	0.012	0.020
c	0.100	0.250	0.004	0.010
D	4.700	5.150	0.185	0.203
E	3.800	4.000	0.150	0.157
E1	5.800	6.200	0.228	0.244
e	1.270 (BSC)		0.050 (BSC)	
L	0.400	1.270	0.016	0.050
θ	0°	8°	0°	8°

**PACKAGE MECHANICAL DATA**

**SOT-23-6L PACKAGE OUTLINE DIMENSIONS**

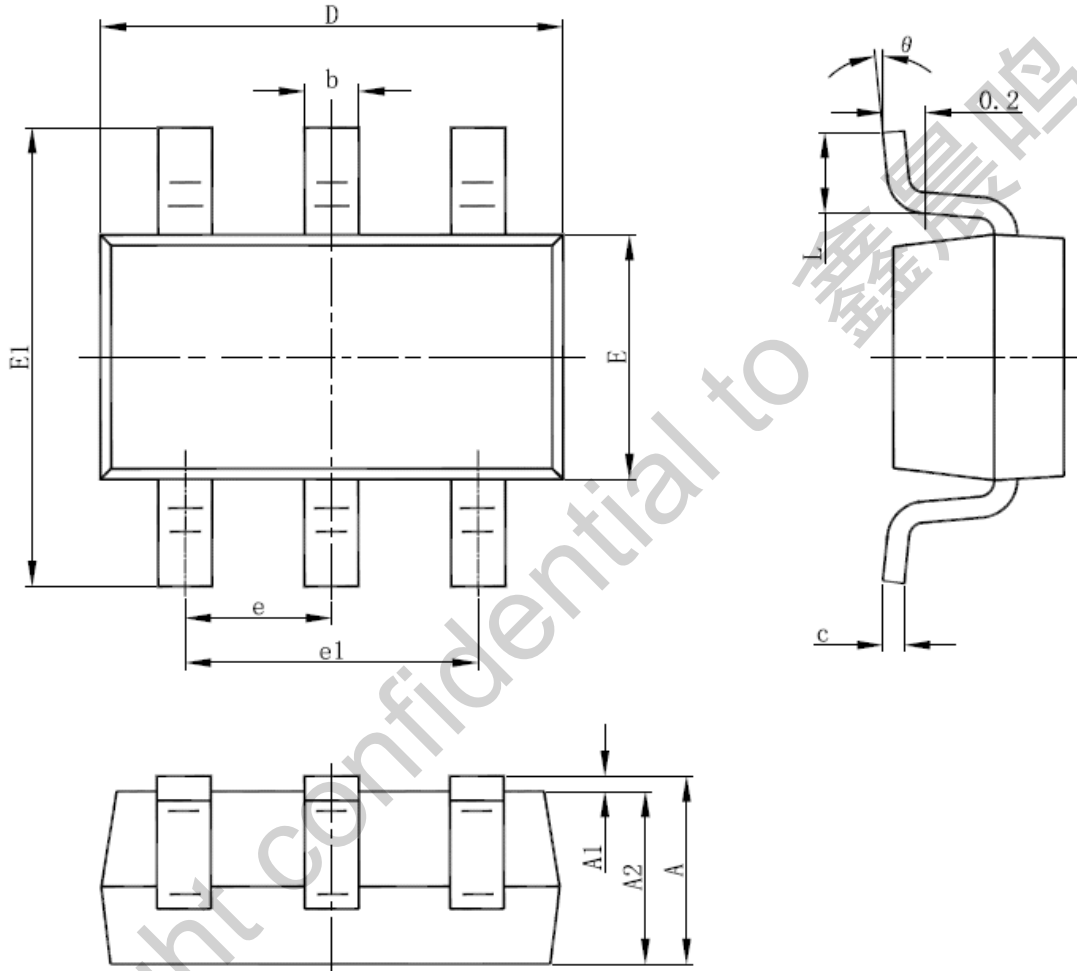

Symbol	Dimensions In Millimeters		Dimensions In Inches	
	Min	Max	Min	Max
A	1.000	1.450	0.039	0.057
A1	0.000	0.150	0.000	0.006
A2	0.900	1.300	0.035	0.051
b	0.300	0.500	0.012	0.020
c	0.080	0.220	0.003	0.009
D	2.800	3.020	0.110	0.119
E	1.500	1.726	0.059	0.068
E1	2.600	3.000	0.102	0.118
e	0.950 (BSC)		0.037 (BSC)	
e1	1.800	2.000	0.071	0.079
L	0.300	0.600	0.012	0.024
θ	0°	8°	0°	8°



## IMPORTANT NOTICE

### RIGHT TO MAKE CHANGES

On-Bright Electronics Corp. reserves the right to make corrections, modifications, enhancements, improvements and other changes to its products and services at any time and to discontinue any product or service without notice. Customers should obtain the latest relevant information before placing orders and should verify that such information is current and complete.

### WARRANTY INFORMATION

On-Bright Electronics Corp. warrants performance of its hardware products to the specifications applicable at the time of sale in accordance with its standard warranty. Testing and other quality control techniques are used to the extent it deems necessary to support this warranty. Except where mandated by government requirements, testing of all parameters of each product is not necessarily performed. On-Bright Electronics Corp. assumes no liability for application assistance or customer product design. Customers are responsible for their products and applications using On-Bright's components, data sheet and application notes. To minimize the risks associated with customer products and applications, customers should provide adequate design and operating safeguards.

### LIFE SUPPORT

On-Bright Electronics Corp.'s products are not designed to be used as components in devices intended to support or sustain human life. On-bright Electronics Corp. will not be held liable for any damages or claims resulting from the use of its products in medical applications.

### MILITARY

On-Bright Electronics Corp.'s products are not designed for use in military applications. On-Bright Electronics Corp. will not be held liable for any damages or claims resulting from the use of its products in military applications.

## X-ON Electronics

Largest Supplier of Electrical and Electronic Components

*Click to view similar products for [Switching Controllers](#) category:*

*Click to view products by [On-Bright](#) manufacturer:*

Other Similar products are found below :

[LV5725JAZ-AH](#) [AP3844CMTR-E1](#) [NCP1218AD65R2G](#) [NCP1234AD100R2G](#) [NCP1244BD065R2G](#) [NCP1336ADR2G](#) [NCP6153MNTWG](#)  
[NCP81101BMNTXG](#) [NCP81205MNTXG](#) [CAT874-80ULGT3](#) [SJE6600](#) [AZ7500BMTR-E1](#) [IR35215MTRPBF](#) [SG3845DM](#)  
[NCP4204MNTXG](#) [NCP6132AMNR2G](#) [NCP81102MNTXG](#) [NCP81203MNTXG](#) [NCP81206MNTXG](#) [NX2155HCUPTR](#) [UBA2051C](#)  
[IR35201MTRPBF](#) [AP3842CMTR-E1](#) [NCP1247AD065R2G](#) [NCP1015ST65T3G](#) [NCP1240AD065R2G](#) [NCP1240FD065R2G](#)  
[NCP1361BABAYSNT1G](#) [NCP1230P100G](#) [NCP1612BDR2G](#) [NX2124CSTR](#) [SG2845M](#) [NCP1366BABAYDR2G](#) [NCP81101MNTXG](#)  
[TEA19362T/1J](#) [NCP81174NMNTXG](#) [NCP4308DMTTWG](#) [NCP4308DMNTWG](#) [NCP4308AMTTWG](#) [NCP1366AABAYDR2G](#)  
[NCP1256ASN65T1G](#) [NCP1251FSN65T1G](#) [NCP1246BLD065R2G](#) [MB39A136PFT-G-BND-ERE1](#) [NCP1256BSN100T1G](#) [LV5768V-A-](#)  
[TLM-E](#) [NCP1365BABCYDR2G](#) [NCP1365AABCYDR2G](#) [IR35204MTRPBF](#) [MCP1633T-E/MG](#)