

GENERAL DESCRIPTION

The OB3379X is a high efficiency LED driver designed for white LEDs lighting and backlight. OB3379X is built-in a quasi-resonant control method buck DC/DC converter. The controller implements a peak current mode control scheme and an internal transconductance amplifier to accurately control the output current over a wide input and load conditions. The transconductance amplifier reference is set by internal reference voltage which determined by the input of ADIM pin and the duty cycle at HPWM pin.

OB3379X offers comprehensive protection features to protect the system in various fault conditions such as Diode & Inductor short protection, CS open protection, LED+/LED- short protection, LED open loop protection, Over temperature protection (OTP). The cycle-by-cycle current limit function limits the maximum current flowing through the external MOSFET.

OB3379X is offered in SOP8 package.

FEATURES

- Low system cost and high efficiency
- Quasi-Resonant buck topology operation
- Programmable CC regulation
- 1%-100% Analog and PWM to analog combination dimming
- Zero voltage signal detected to improve efficiency and EMI performance
- LED+/LED- short circuit protection
- LED open loop protection
- Cycle-by-cycle current limiting
- Built-in leading edge blanking (LEB)
- VIN under voltage lockout with hysteresis
- Over temperature protection (OTP)
- Diode & Inductor short protection
- CS open protection
- Low standby current

APPLICATIONS

- LED lighting
- LED backlight

TYPICAL APPLICATION

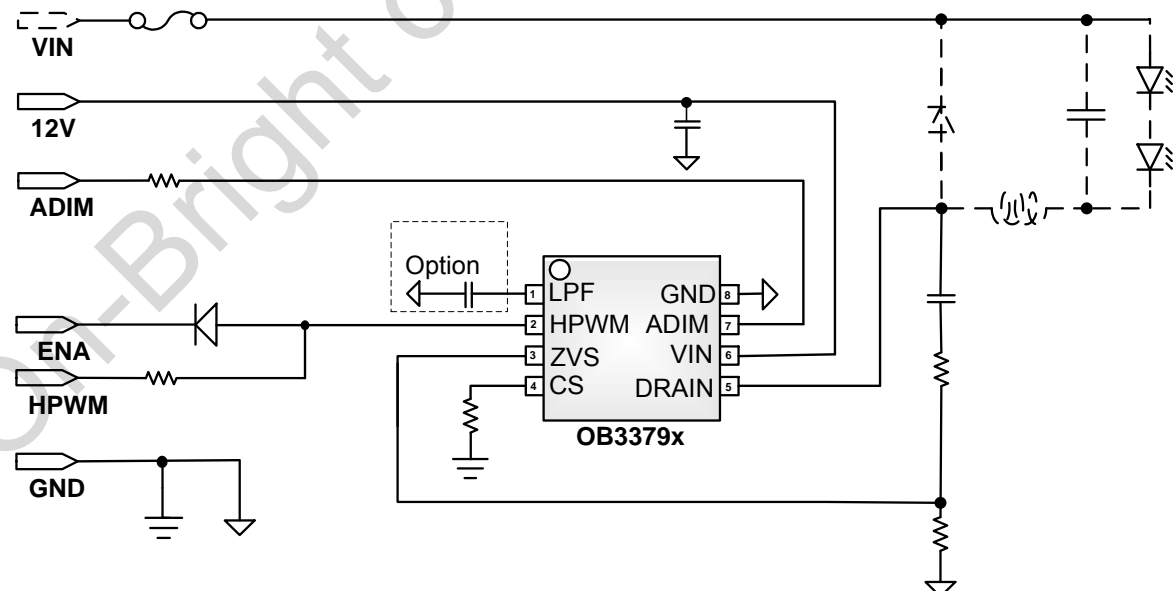

GENERAL INFORMATION

Absolute Maximum Ratings

| Parameter | Value |
|---|----------------|
| VIN, ADIM, HPWM, LPF to GND | -0.3V to 35V |
| ZVS ^{2/3} to GND | -0.7V to 35V |
| CS to GND | -0.3V to 7V |
| DRAIN to GND | -0.3V to BVdss |
| Operating Ambient Temp. T _A | -40°C ~ 85°C |
| Operating Junction Temp. T _J | -40°C ~ 150°C |
| Min/Max Storage Temp. T _{stg} | -55°C ~ 150°C |
| Lead Temp. (10 Sec) | 260°C |

Note1: Stresses beyond those listed under "absolute maximum ratings" may cause permanent damage to the device. These are stress ratings only, functional operation of the device at these or any other conditions beyond those indicated under "recommended operating conditions" is not implied. Exposure to absolute maximum-rated conditions for extended periods may affect device reliability.

Note2: Rating value refers to DC only. For small duty cycle pulse in less than 500ns in one period (typical 8.33us), negative spike value is relaxed to -1.3V.

Note3: The negative voltage amplitude is relaxed to -0.7V under the condition that its max negative current is in less than 3mA.

Package Thermal Characteristics

| Parameter | RθJA (°C/W) |
|-----------|-------------|
| SOP8 | 110 |

Recommended Operating Range

| Parameter | Value |
|------------------------------|----------------------------|
| Vin Voltage | 9V to 30V |
| ADIM Voltage | 0V to 5V |
| HPWM Dimming Frequency | 200Hz to 40KHz |
| ZVS Positive Plateau Voltage | 0.8V to V _{thZVS} |

Ordering Information

| Part Number | Description |
|--------------|----------------------------|
| OB3379ZCP-D | SOP8, Halogen-free in tube |
| OB3379ZCPA-D | SOP8, Halogen-free in T&R |
| OB3379YCP-D | SOP8, Halogen-free in Tube |
| OB3379YCPA-D | SOP8, Halogen-free in T&R |

Output Power Table

| Product | Condition | Max. output voltage | Max. output power |
|-------------|----------------------|---------------------|-------------------|
| OB3379ZCP-D | I _o =1.8A | 90V | 162W |
| OB3379YCP-D | I _o =1A | 60V | 60W |

Note: Maximum practical continuous power in an open frame design with sufficient drain pattern as a heat sink, at 50°C ambient and 60°C temperature rise. Higher output power is possible with extra added heat sink, air circulation and decrease output current to reduce thermal resistance.

Maximum output voltage should not exceed 90% of the internal MOSFET Drain-Source Breakdown Voltage.

Marking Information

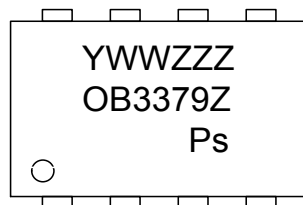
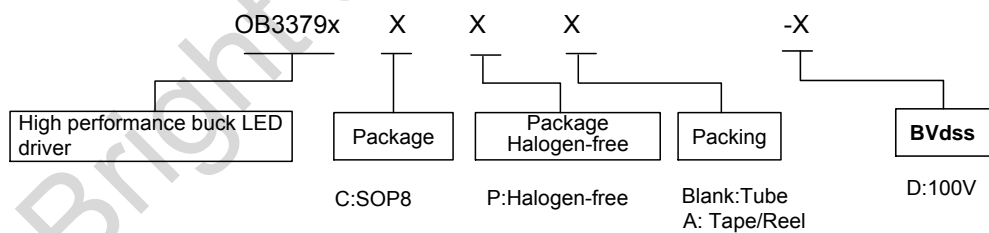

Y:Year Code
 WW:Week Code(01-52)
 ZZZ:Lot Code
 P:Halogen-free Package
 s:Internal Code(Optional)

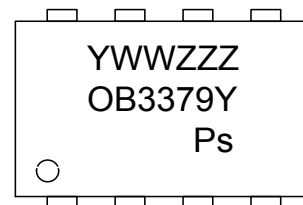

Y:Year Code
 WW:Week Code(01-52)
 ZZZ:Lot Code
 P:Halogen-free Package
 s:Internal Code(Optional)

Terminal Assignments

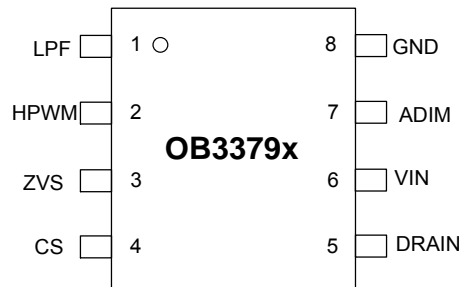

| Pin Num | Pin Name | I/O | Description |
|---------|----------|-----|--|
| 1 | LPF | I/O | In PWM to analog dimming, if the HPWM Dimming Frequency is between 10kHz and 40kHz, the LPF pin is floating ; if the HPWM Dimming Frequency is between 200Hz and 10kHz, a capacitor is suggest to connect between the LPF pin and GND to reduce output current ripple. |
| 2 | HPWM | I/O | HPWM signal input pin for PWM to analog dimming control |
| 3 | ZVS | I/O | Quasi-Resonant signal |
| 4 | CS | I/O | Current sensing terminal. |
| 5 | DRAIN | I/O | Drain of internal MOSFET |
| 6 | VIN | P | Power supply input. |
| 7 | ADIM | I/O | The input voltage of ADIM pin determines the voltage of internal reference voltage which decides the LED current. |
| 8 | GND | P | Power Ground. |

BLOCK DIAGRAM

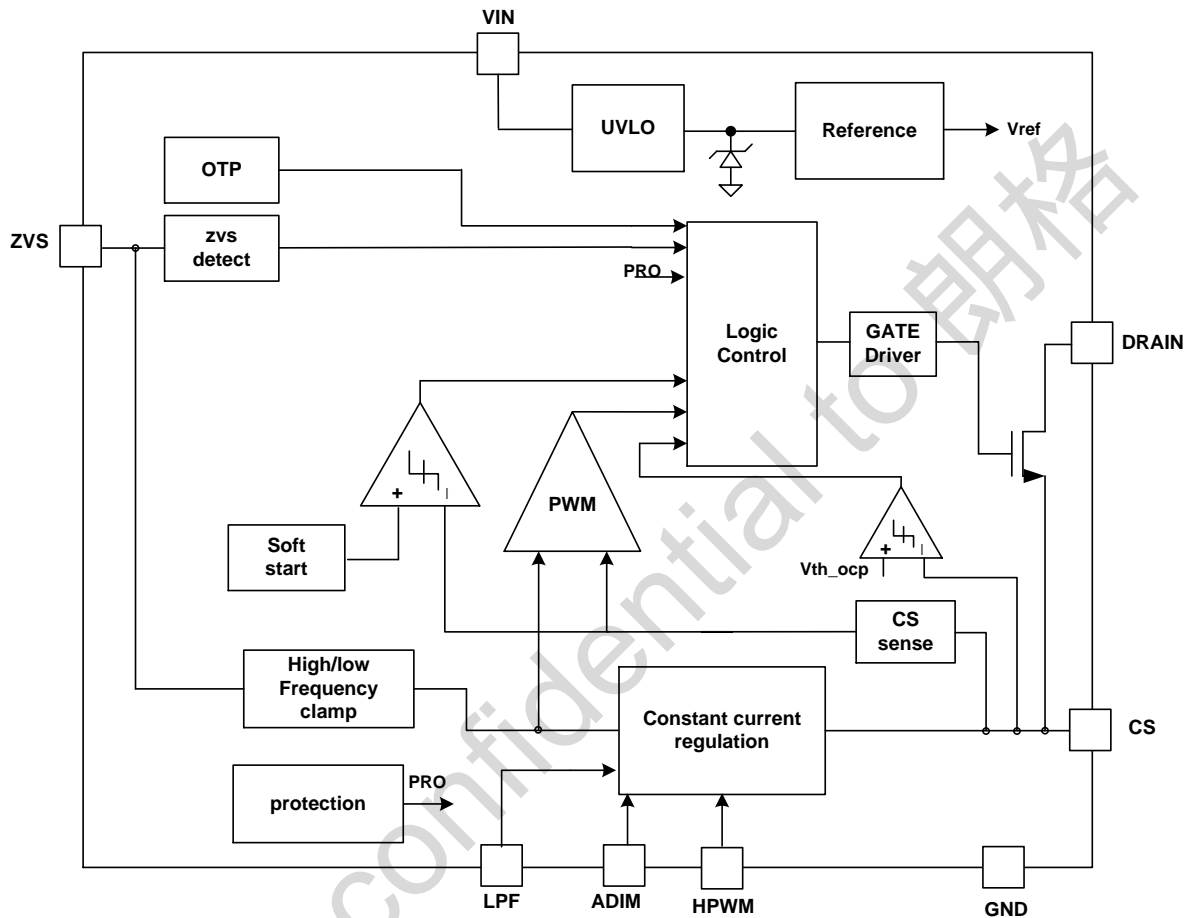

ELECTRICAL CHARACTERISTICS

V_{IN}=12V,HPWM=5V, T_A=25°C, if not otherwise noted.

| Parameter | Symbol | Conditions | Min | Typ. | Max | Units |
|--|--------------------------|--------------------------------------|-----|------|-----|-------|
| Current Consumption | | | | | | |
| Input voltage range | V _{in} | | 9 | | 30 | V |
| Operating supply current | I _{Vin} | V _{in} =12V,HPWM=5V no load | | 1.1 | 1.3 | mA |
| Stand by current | I _{Vin_stb} | HPWM low >15ms sleep mode | | 20 | 30 | uA |
| VIN UVLO | | | | | | |
| Vin under voltage lockout exit (recovery) | UVLO(OFF) | | 7 | 8 | 9 | V |
| Vin under voltage lockout enter | UVLO(ON) | | 6.2 | 7.2 | 8.2 | V |
| Analog Dimming Control | | | | | | |
| ADIM Inner Clamp Voltage | V _{ADIM} | ADIM=2.5V | | 250 | | mV |
| HPWM Control | | | | | | |
| HPWM Input Threshold | HPWM(high) | High Level | 2.5 | | | V |
| | HPWM(low) | Low Level | | | 1.3 | V |
| Sleep mode time | T _{sleep} | | | 15 | | ms |
| Current Sense Input Section | | | | | | |
| Threshold of over current protection | V _{th_ocp} | | | 0.8 | | V |
| QR Section | | | | | | |
| Max frequency | F max | | | 230 | | KHz |
| Max gate off time | Toff max | | 90 | 113 | 135 | us |
| Max gate on time | Ton max | | 20 | 25 | 30 | us |
| Constant current Section | | | | | | |
| Time of leading edge blanking | T _{leb} | | | 350 | | ns |
| Reference voltage of Error amplifier | V _{th_ea} | | 245 | 250 | 255 | mV |
| Protection | | | | | | |
| Threshold of diode & Inductor short protection | V _{th_cs_high1} | | | 1.5 | | V |
| Threshold of CS pin open protection | V _{th_cs_high2} | | | 2 | | V |
| Temperature of thermal shutdown | T _{OTP_ON} | | | 150 | | °C |
| Temperature of thermal shutdown | T _{OTP_OFF} | | | 100 | | °C |
| Threshold of ZVS pin LED open protection | V _{th_ZVS} | | 3.8 | 4 | 4.2 | V |

| Product | Parameter | BVdss(V) MOSFET Drain-Source Breakdown Voltage | | |
|-------------|-----------|---|------|-----|
| | | Min | Typ. | Max |
| OB3379ZCP-D | | 100 | | |
| OB3379YCP-D | | 100 | | |

CHARACTERIZATION PLOTS

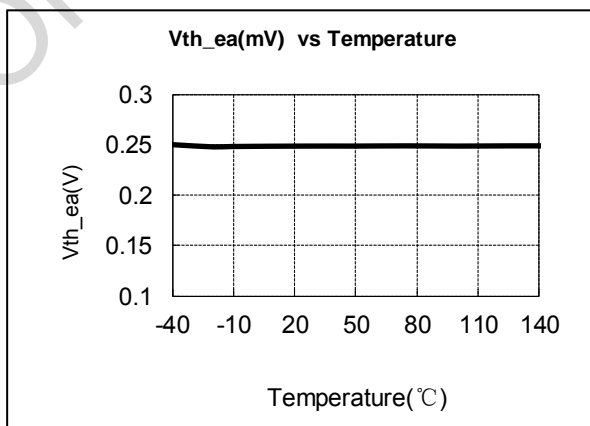
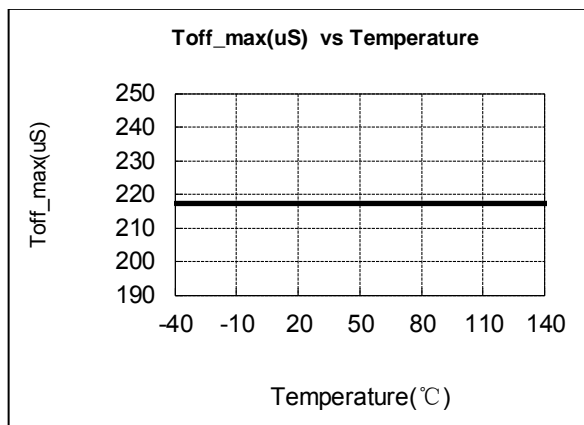
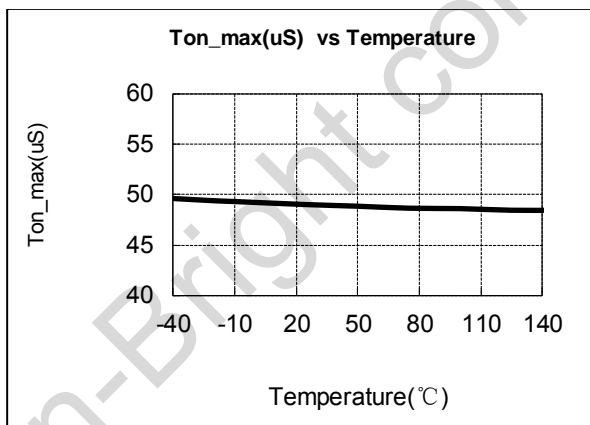
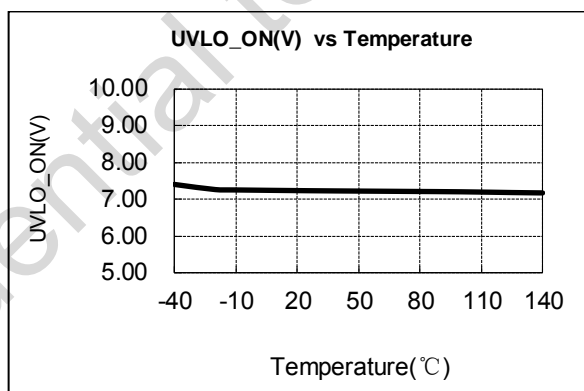
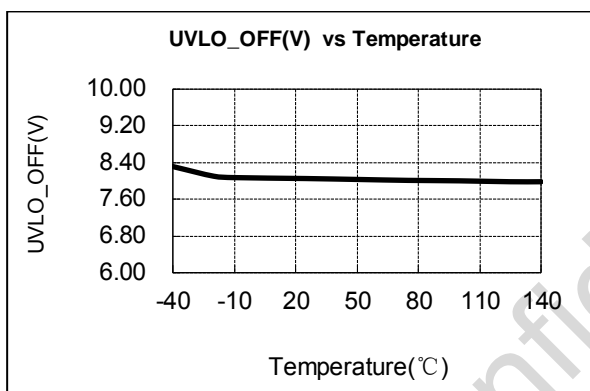
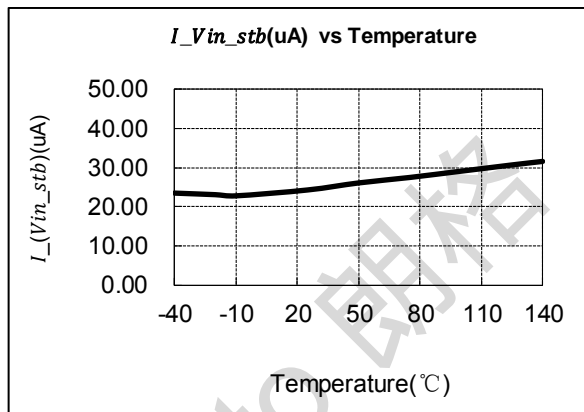
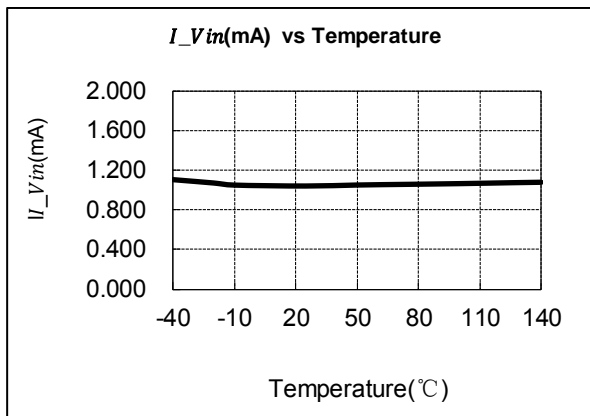

Function Description

General Operation

The OB3379X is a high efficiency LED driver designed for white LEDs lighting and backlight. OB3379X is built-in a quasi-resonant control method buck DC/DC converter. The controller implements a peak current mode control scheme and an internal transconductance amplifier to accurately control the output current over a wide input and load conditions. The transconductance amplifier reference is set by internal reference voltage which determined by the input of ADIM pin and the duty cycle at HPWM pin.

OB3379X offers comprehensive protection features to protect the system in various fault conditions such as Diode & Inductor short protection, CS open protection, LED+/LED- short protection, over temperature protection (OTP). The cycle-by-cycle current limit function limits the maximum current flowing through the external MOSFET.

Startup

OB3379X is enabled by applying a voltage of greater than approximately 2.5V to HPWM pin. An on-chip internal 3.8M ohm pull down resistor is inserted between HPWM pin and ground. When the first rising edge is applied to HPWM input, the OB3379X will power up immediately, and remains power up until the HPWM input is lower than 1.3V for 15mS (typical), at this time the chip will enter standby mode. At standby mode, the power of the OB3379X will be lower than 20uA (typical).

When HPWM is active high, The OB3379X will check faults (UVLO, CS high, LED+/LED- short, LED open, OCP), if there is no fault, then the buck converter will start up with the internal soft start.

UVLO

An under-voltage lockout protection feature with a hysteresis of about 800mv is provided for VIN. When the voltage at this pin exceeds a threshold of approximately 8V (typ.), the IC starts normal operation. If the voltage at this pin drops below a threshold of approximately 7.2V (typ.) , the IC stops switching operation. The IC resumes switching operation when the voltage at pin VIN increases to a voltage above 8V (typical).

LED Current Regulation

The LED current is sensed by current sense resistors connected between pin CS and GND. The sensed error signal is amplified and compared to the CS pin sensing current signal to determine the on-time of the switching MOSFET. The error amplifier sources or sinks the current to the internal COMP to adjust the required

inductor current as the load changes.

The error amplifier reference is set by internal reference voltage which determined by the input of ADIM pin and the duty cycle at HPWM pin.

The average LED current is approximated by the following equation;

$$I_{LED}[mA] = \frac{V_{th_ea}[mV]}{R_{CS}[\Omega]}$$

At light loading, the OB3379X automatically add off time to improve efficiency and prevent overcharging the output capacitor.

Dimming Control

The OB3379X supports Analog and PWM to analog combination dimming which allow flexible control of the luminance. The LED current is directly modulated by the voltage of ADIM pin and PWM duty cycle on HPWM pin.

The relationship between the error amplifier reference voltage and the input voltage of ADIM pin voltage can be seen in Figure 1,

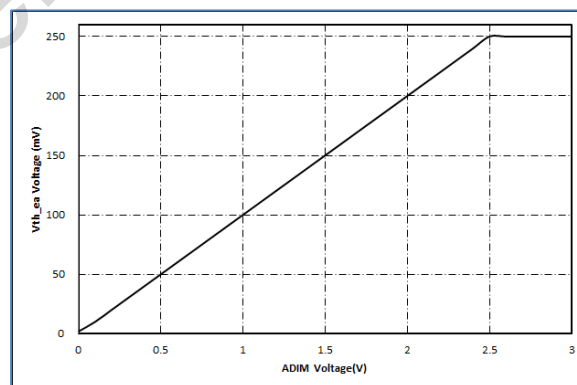

Figure1: Vth_ea voltage VS. ADIM voltage

The relationship between the error amplifier reference voltage and PWM duty cycle on HPWM pin can be seen in Figure 2,

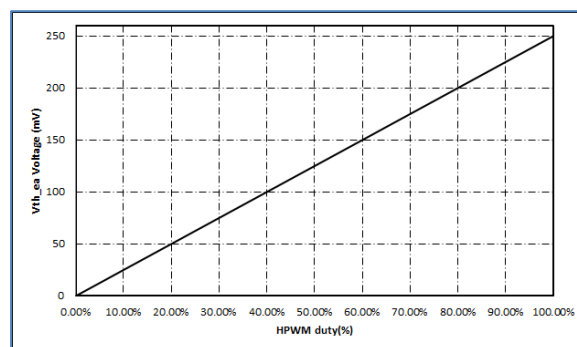

Figure2: Vth_ea voltage VS. HPWM duty

CS pin open Protection

OB3379X shuts down the output if CS pin is floating. In case of CS pin floating, OB3379X will pull up CS pin to internal 5V voltage. If the CS voltage is greater than 2V (typical), the IC will shut down. OB3379X resumes normal operation after the fault condition is removed.

LED+/LED- short

When LED+/ LED- short, IC can not detected demagnetization information, OB3379X will continuously work at max_off state. OB3379X resumes normal operation after the fault condition is removed.

LED Open Protection

When the LED string open happens, the positive plateau of the ZVS pin voltage increases. If the voltage at ZVS pin is higher than a threshold of approximately 4V (typical) continuous 4 cycles, the IC will shut down and

do not restart until after 30ms (typical) .

Diode & Inductor Short Protection

When the diode or the inductor shorts, the current of the power MOSFET increasing significantly. This state will cause the MOSFET permanent damage if the IC is continuously working. OB3379X will monitor the voltage on CS pin voltage cycle by cycle. If the voltage on CS pin is greater than 1.5V (typical) for continuous 16 cycles, the IC will shut down and do not restart until after 30ms (typical) .

Thermal Shutdown

The OB3379X includes a thermal protection circuit. When the junction temperature exceeds 150°C (typical), the IC will shut down and do not restart until the junction temperature drops below 100°C (typical).

Layout Consideration

Careful attention must be paid to the PCB board layout and components placement. Proper layout of the high frequency switching path is critical to prevent noise and electromagnetic interference problems. Using the following guidelines for good PCB layout:

- 1) The loop of C8→C9→L1→DRAIN PIN→CS PIN→GND and L1→D2→C9 is flowing with high frequency pulse current. It must be as small as possible; Use wide and short trace for connecting the buck switching components (inductor (L1), diode (D2), and output capacitor (C9)).
- 2) In order to reduce interference from power ground, The PGND should be separated from the AGND. The ground of CS resistor should be connected with the AGND first, then tied together at negative pole of the input capacitor

(C8).

- 3) The ground of IC peripheral devices should be connected to the AGND. The main board ground, IC ground and CS resistors ground should be converged at the input capacitance (C8). Otherwise the IC may be interfered from the SMPS.
- 4) Place the VIN filter capacitor (C1), LPF filter capacitor (C11) as close to the IC as possible.

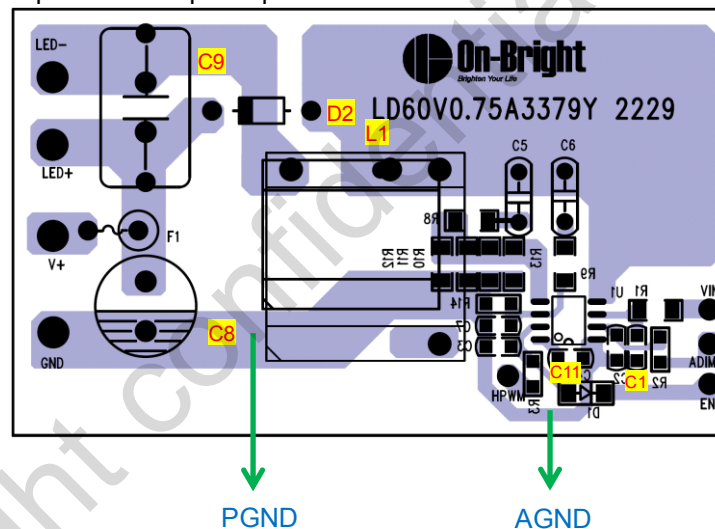

PACKAGE MECHANICAL DATA

SOP8

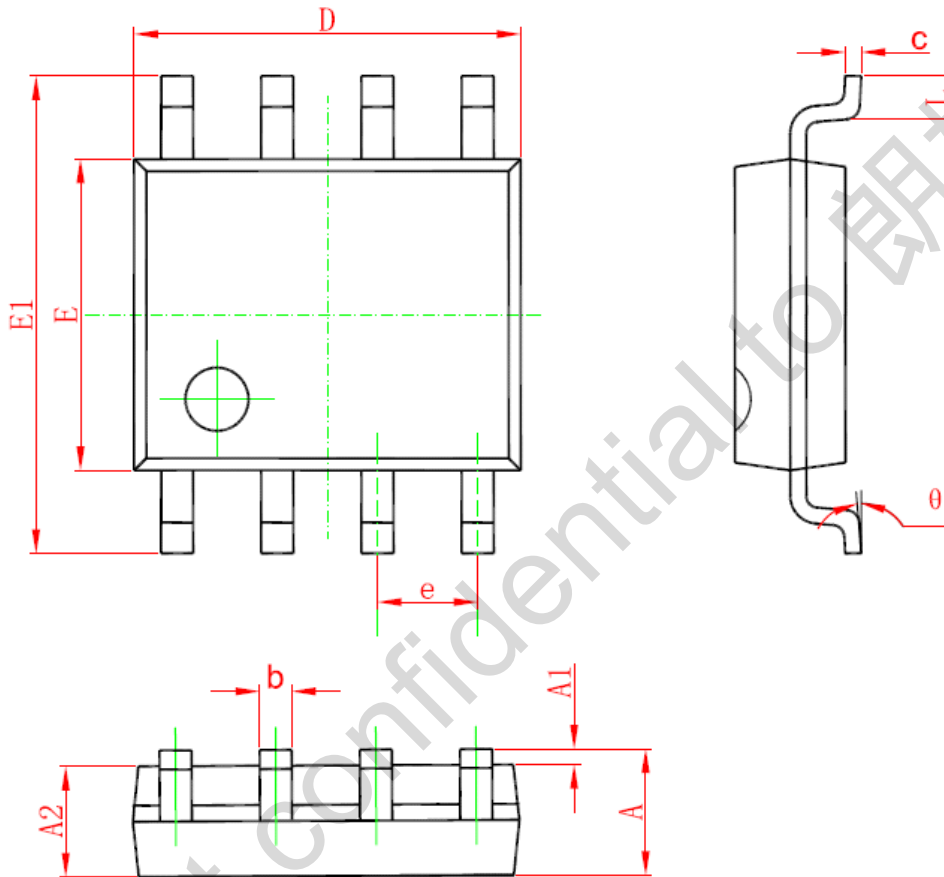

| Symbol | Dimensions In Millimeters | | Dimensions In Inches | |
|--------|---------------------------|-------|----------------------|-------|
| | Min | Max | | Min |
| A | 1.350 | 1.750 | A | 1.350 |
| A1 | 0.050 | 0.250 | A1 | 0.050 |
| A2 | 1.250 | 1.650 | A2 | 1.250 |
| b | 0.310 | 0.510 | b | 0.310 |
| c | 0.100 | 0.250 | c | 0.100 |
| D | 4.700 | 5.150 | D | 4.700 |
| E | 3.700 | 4.100 | E | 3.700 |
| E1 | 5.800 | 6.200 | E1 | 5.800 |
| e | 1.270 (BSC) | | 0.050 (BSC) | |
| L | 0.400 | 1.270 | L | 0.400 |
| θ | 0° | 8° | θ | 0° |

IMPORTANT NOTICE

RIGHT TO MAKE CHANGES

On-Bright Electronics Corp. reserves the right to make corrections, modifications, enhancements, improvements and other changes to its products and services at any time and to discontinue any product or service without notice. Customers should obtain the latest relevant information before placing orders and should verify that such information is current and complete.

WARRANTY INFORMATION

On-Bright Electronics Corp. warrants performance of its hardware products to the specifications applicable at the time of sale in accordance with its standard warranty. Testing and other quality control techniques are used to the extent it deems necessary to support this warranty. Except where mandated by government requirements, testing of all parameters of each product is not necessarily performed.

On-Bright Electronics Corp. assumes no liability for application assistance or customer product design. Customers are responsible for their products and applications using On-Bright's components, data sheet and application notes. To minimize the risks associated with customer products and applications, customers should provide adequate design and operating safeguards.

LIFE SUPPORT

On-Bright Electronics Corp.'s products are not designed to be used as components in devices intended to support or sustain human life. On-bright Electronics Corp. will not be held liable for any damages or claims resulting from the use of its products in medical applications.

MILITARY

On-Bright Electronics Corp.'s products are not designed for use in military applications. On-Bright Electronics Corp. will not be held liable for any damages or claims resulting from the use of its products in military applications.

X-ON Electronics

Largest Supplier of Electrical and Electronic Components

Click to view similar products for [LED Display Drivers](#) category:

Click to view products by [On-Bright](#) manufacturer:

Other Similar products are found below :

[STP16DP05PTR](#) [MP3370GN-Z](#) [ISL97631IHTZ-T7A](#) [ISL97632IRT26Z-T](#) [LV5026MC-AH](#) [IK62083DWT](#) [OB3655TAP-H](#) [OB3399PAP](#)
[AW36514FCR](#) [AW36428FCR](#) [KAQW214A TL](#) [TM1629\(TA2009B\)](#) [WS2814F](#) [XB402U-L27](#) [HT16K33A-20SOP](#) [HT16D33A-28SSOP](#)
[TM1628E](#) [TM512AE0](#) [TM512AD](#) [TM0822B](#) [SY7310AADC](#) [SY58863FAC](#) [SY5863AJAC](#) [FM4115K](#) [TM1638N-SOP28-TA1319B](#)
[SPL5013CNI-TRG](#) [AW21024QNR](#) [AW36423FCR](#) [AW36515FCR](#) [AW99703CSR](#) [AW21036QNR](#) [AW21009QNR](#) [AW20108QNR](#)
[AW2016AQNR](#) [AW9967DNR](#) [PT4115BE89E](#) [CC1108ST](#) [CC1109](#) [SD6800BCTR](#) [SDH7612DH](#) [HT16D35A-48LQFP-EP](#) [HT1635C-](#)
[64LQFP-7*7](#) [HT1632D-52LQFP-2.0](#) [HT16K33A-28SOP](#) [HT16D31A-16NSOP-EP](#) [TLD5099EP](#) [BCR 431U](#) [IS32FL3740-ZLA3-TR](#)
[PAM2804AAB010\(MS\)](#) [OB3379ZCPA-D](#)