

ADM1026

Complete Thermal System Management Controller

The ADM1026 is a complete system hardware monitor for microprocessor-based systems, providing measurement and limit comparison of various system parameters. The ADM1026 has up to 19 analog measurement channels. Fifteen analog voltage inputs are provided, five of which are dedicated to monitoring +3.3 V, +5.0 V, and ± 12 V power supplies, and the processor core voltage. The ADM1026 can monitor two other power supply voltages by measuring its own V_{CC} and the main system supply. One input (two pins) is dedicated to a remote temperature-sensing diode. Two additional pins can be configured as general-purpose analog inputs to measure 0 V to 2.5 V, or as a second temperature sensing input. The eight remaining inputs are general-purpose analog inputs with a range of 0 V to 2.5 V or 0 V to 3.0 V. The ADM1026 also has an on-chip temperature sensor.

The ADM1026 has eight pins that can be configured for fan speed measurement or as general-purpose logic I/O pins. Another eight pins are dedicated to general-purpose logic I/O. An additional pin can be configured as a general-purpose I/O or as the bidirectional $\overline{\text{THERM}}$ pin.

Measured values can be read out via a 2-wire serial system management bus, and values for limit comparisons can be programmed over the same serial bus. The high speed, successive approximation ADC allows frequent sampling of all analog channels to ensure a fast interrupt response to any out-of-limit measurement.

Features

- Up to 19 Analog Measurement Channels (Including Internal Measurements)
- Up to 8 Fan Speed Measurement Channels
- Up to 17 General-Purpose Logic I/O Pins
- Remote Temperature Measurement with Remote Diode (Two Channels)
- On-Chip Temperature Sensor
- Analog and PWM Fan Speed Control Outputs
- 2-Wire Serial System Management Bus (SMBus)
- 8 kB On-Chip EEPROM
- Full SMBus 1.1 Support Includes Packet Error Checking (PEC)
- Chassis Intrusion Detection
- Interrupt Output (SMBAlert)
- Reset Input, Reset Outputs
- Thermal Interrupt ($\overline{\text{THERM}}$) Output
- Limit Comparison of All Monitored Values
- This is a Pb-Free Device*

Applications

- Network Servers and Personal Computers
- Telecommunications Equipment
- Test Equipment and Measuring Instruments

*For additional information on our Pb-Free strategy and soldering details, please download the ON Semiconductor Soldering and Mounting Techniques Reference Manual, SOLDERRM/D.



ON Semiconductor®

<http://onsemi.com>

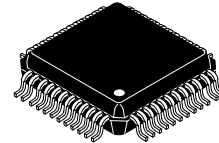

LQFP-48
CASE 932

MARKING DIAGRAM

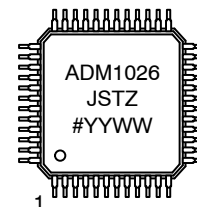

ADM1026JSTZ = Special Device Code
= Pb-Free Package
YYWW = Date Code

ORDERING INFORMATION

See detailed ordering and shipping information in the package dimensions section on page 54 of this data sheet.

ADM1026

PIN ASSIGNMENT

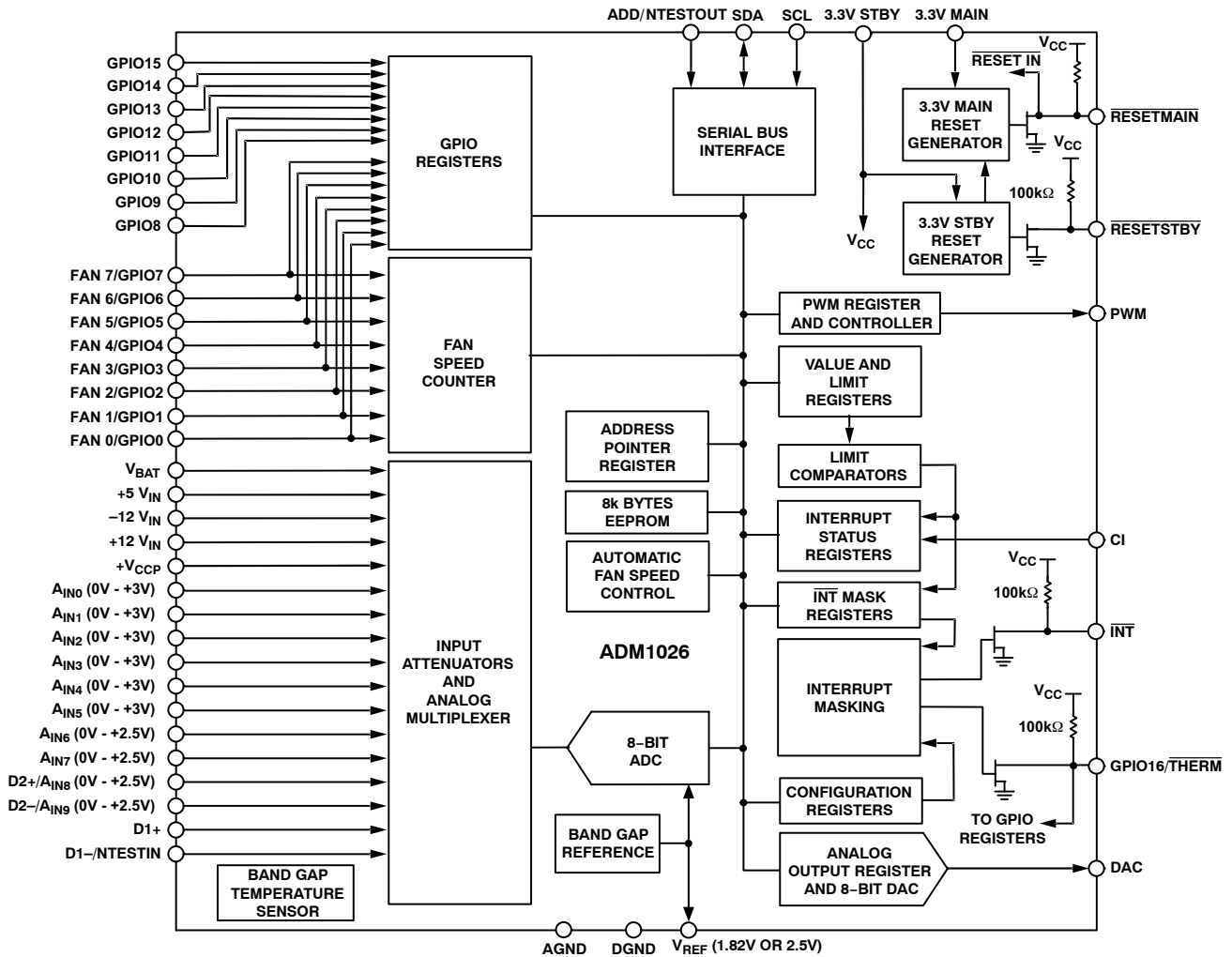
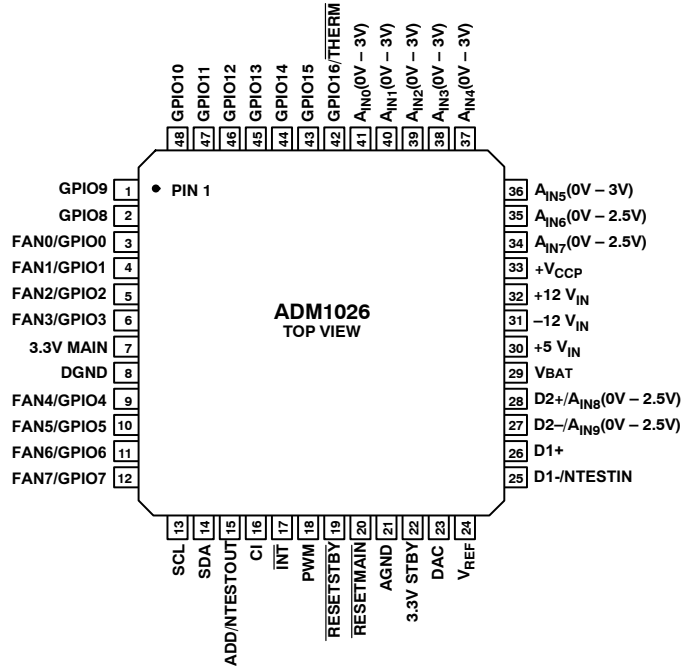

Figure 1. Functional Block Diagram

ADM1026

Table 1. ABSOLUTE MAXIMUM RATINGS

Parameter	Rating	Unit
Positive Supply Voltage (V_{CC})	6.5	V
Voltage on +12 V_{IN} Pin	+20	V
Voltage on -12 V_{IN} Pin	-20	V
Voltage on Analog Pins	-0.3 to ($V_{CC} + 0.3$)	V
Voltage on Open-drain Digital Pins	-0.3 to +6.5	V
Input Current at Any Pin	± 5	mA
Package Input Current	± 20	mA
Maximum Junction Temperature (T_{JMAX})	150	$^{\circ}C$
Storage Temperature Range	-65 to +150	$^{\circ}C$
Lead Temperature, Soldering Vapor Phase (60 sec) Infrared (15 sec)	215 200	$^{\circ}C$
ESD Rating -12 V_{IN} Pin All Other Pins	1000 2000	V

Stresses exceeding Maximum Ratings may damage the device. Maximum Ratings are stress ratings only. Functional operation above the Recommended Operating Conditions is not implied. Extended exposure to stresses above the Recommended Operating Conditions may affect device reliability.

NOTE: This device is ESD sensitive. Use standard ESD precautions when handling.

Table 2. THERMAL CHARACTERISTICS

Package Type	θ_{JA}	θ_{JC}	Unit
48-lead LQFP	50	10	$^{\circ}C/W$

Table 3. PIN ASSIGNMENT

Pin No.	Mnemonic	Type	Description
1	GPIO9	Digital I/O [†]	General-purpose I/O pin that can be configured as digital inputs or outputs.
2	GPIO8	Digital I/O [†]	General-purpose I/O pin that can be configured as digital inputs or outputs.
3	FAN0/GPIO0	Digital I/O	Fan tachometer input with internal 10 k Ω pullup resistor to 3.3 V STBY. Can be reconfigured as a general-purpose, open drain, digital I/O pin.
4	FAN1/GPIO1	Digital I/O	Fan tachometer input with internal 10 k Ω pullup resistor to 3.3 V STBY. Can be reconfigured as a general-purpose, open drain, digital I/O pin.
5	FAN2/GPIO2	Digital I/O	Fan tachometer input with internal 10 k Ω pullup resistor to 3.3 V STBY. Can be reconfigured as a general-purpose, open drain, digital I/O pin.
6	FAN3/GPIO3	Digital I/O	Fan tachometer input with internal 10 k Ω pullup resistor to 3.3 V STBY. Can be reconfigured as a general-purpose, open drain, digital I/O pin.
7	3.3 V MAIN	Analog Input	Monitors the main 3.3 V system supply. Does not power the device.
8	DGND	Ground	Ground pin for digital circuits.
9	FAN4/GPIO4	Digital I/O	Fan tachometer input with internal 10 k Ω pullup resistor to 3.3 V STBY. Can be reconfigured as a general-purpose, open drain, digital I/O pin.
10	FAN5/GPIO5	Digital I/O	Fan tachometer input with internal 10 k Ω pullup resistor to 3.3 V STBY. Can be reconfigured as a general-purpose, open drain, digital I/O pin.
11	FAN6/GPIO6	Digital I/O	Fan tachometer input with internal 10 k Ω pullup resistor to 3.3 V STBY. Can be reconfigured as a general-purpose, open drain, digital I/O pin.
12	FAN7/GPIO7	Digital I/O	Fan tachometer input with internal 10 k Ω pullup resistor to 3.3 V STBY. Can be reconfigured as a general-purpose, open drain, digital I/O pin.
13	SCL	Digital Input	Open Drain Serial Bus Clock. Requires a 2.2 k Ω pullup resistor.
14	SDA	Digital I/O	Serial Bus Data. Open drain I/O. Requires a 2.2 k Ω pullup resistor.
15	ADD/NTESTOUT	Digital Input	This is a three-state input that controls the two LSBs of the serial bus address. It also functions as the output for NAND tree testing.
16	CI	Digital Input	An active high input that captures a chassis intrusion event in Bit 6 of Status Register 4. This bit remains set until cleared, as long as battery voltage is applied to the V_{BAT} input, even when the ADM1026 is powered off.

ADM1026

Table 3. PIN ASSIGNMENT

Pin No.	Mnemonic	Type	Description
17	INT	Digital Output	Interrupt Request (Open Drain). The output is enabled when Bit 1 of the configuration register is set to 1. The default state is disabled. It has an on-chip 100 kΩ pullup resistor.
18	PWM	Digital Output	Open drain pulse width modulated output for control of the fan speed. This pin defaults to high for the 100% duty cycle for use with NMOS drive circuitry. If a PMOS device is used to drive the fan, the PWM output may be inverted by setting Bit 1 of Test Register 1 = 1.
19	RESETSTBY	Digital Output	Power-on Reset. 5 mA driver (weak 100 kΩ pullup), active low output (100 kΩ pullup) with a 180 ms typical pulse width. RESETSTBY is asserted whenever 3.3 V STBY is below the reset threshold. It remains asserted for approximately 180 ms after 3.3 V STBY rises above the reset threshold.
20	RESETMAIN	Digital I/O	Power-on Reset. 5 mA driver (weak 100 kΩ pullup), active low output (100 kΩ pullup) with a 180 ms typical pulse width. RESETMAIN is asserted whenever 3.3 V MAIN is below the reset threshold. It remains asserted for approximately 180 ms after 3.3 V MAIN rises above the reset threshold. If, however, 3.3 V STBY rises with or before 3.3 V MAIN, then RESETMAIN remains asserted for 180 ms after RESETSTBY is deasserted. Pin 20 also functions as an active low RESET input.
21	AGND	Ground	Ground pin for analog circuits.
22	3.3 V STBY	Power Supply	Supplies 3.3 V power. Also monitors the 3.3 V standby power rail.
23	DAC	Analog Output	0 V to 2.5 V output for analog control of the fan speed.
24	VREF	Analog Output	Reference Voltage Output. Can be selected as 1.8 V (default) or 2.5 V.
25	D1-/NTESTIN	Analog Input	Connected to a cathode of the first remote temperature sensing diode. If it is held high at power-on, it activates the NAND tree test mode.
26	D1+	Analog Input	Connected to the anode of the first remote temperature sensing diode.
27	D2-/AIN9	Programmable	Connected to the cathode of the second remote temperature sensing diode or the analog input may be reconfigured as a 0 V – 2.5 V analog input.
28	D2+/AIN8	Programmable	Connected to the anode of the second remote temperature sensing diode, or the analog input may be reconfigured as a 0 V – 2.5 V analog input.
29	VBAT	Analog Input	Monitors battery voltage, nominally +3.0 V.
30	+5.0 VIN	Analog Input	Monitors the +5.0 V supply.
31	-12 VIN	Analog Input	Monitors the -12 V supply.
32	+12 VIN	Analog Input	Monitors the +12 V supply.
33	+VCCP	Analog Input	Monitors the processor core voltage (0 V to 3.0 V).
34	AIN7	Analog Input	General-purpose 0 V to 2.5 V analog inputs.
35	AIN6	Analog Input	General-purpose 0 V to 2.5 V analog inputs.
36	AIN5	Analog Input	General-purpose 0 V to 3.0 V analog inputs.
37	AIN4	Analog Input	General-purpose 0 V to 3.0 V analog inputs.
38	AIN3	Analog Input	General-purpose 0 V to 3.0 V analog inputs.
39	AIN2	Analog Input	General-purpose 0 V to 3.0 V analog inputs.
40	AIN1	Analog Input	General-purpose 0 V to 3.0 V analog inputs.
41	AIN0	Analog Input	General-purpose 0 V to 3.0 V analog inputs.
42	GPIO16/THERM	Digital I/O†	General-purpose I/O pin that can be configured as a digital input or output. Can also be configured as a bidirectional THERM pin (100 kΩ pullup).
43	GPIO15	Digital I/O†	General-purpose I/O pin that can be configured as a digital input or output.
44	GPIO14	Digital I/O†	General-purpose I/O pin that can be configured as a digital input or output.
45	GPIO13	Digital I/O†	General-purpose I/O pin that can be configured as a digital input or output.
46	GPIO12	Digital I/O†	General-purpose I/O pin that can be configured as a digital input or output.
47	GPIO11	Digital I/O†	General-purpose I/O pin that can be configured as a digital input or output.
48	GPIO10	Digital I/O†	General-purpose I/O pin that can be configured as a digital input or output.

†GPIO pins are open drain and require external pullup resistors. Fan inputs have integrated 10 kΩ pullups, but these pins become open drain when reconfigured as GPIOs.

ADM1026

Table 4. ELECTRICAL CHARACTERISTICS ($T_A = T_{MIN}$ to T_{MAX} , $V_{CC} = V_{MIN}$ to V_{MAX} , unless otherwise noted. (Note 1, 2, and 3))

Parameter	Test Conditions/Comments	Min	Typ	Max	Unit
POWER SUPPLY					
Supply Voltage, 3.3 V STBY		3.0	3.3	5.5	V
Supply Current, I_{CC}	Interface Inactive, ADC Active	–	2.5	4.0	mA
TEMPERATURE-TO-DIGITAL CONVERTER					
Internal Sensor Accuracy		–	–	±3.0	°C
Resolution		–	±1.0	–	°C
External Diode Sensor Accuracy	$0^{\circ}\text{C} < T_D < 100^{\circ}\text{C}$	–	–	±3.0	°C
Resolution		–	±1.0	–	°C
Remote Sensor Source Current	High Level Low Level	– –	90 5.5	– –	μA
ANALOG-TO-DIGITAL CONVERTER (Including MUX and ATTENUATORS)					
Total Unadjusted Error (TUE) (Note 4)		–	–	±2.0	%
Differential Non-linearity (DNL)		–	–	±1.0	LSB
Power Supply Sensitivity		–	±0.1		%/V
Conversion Time (Analog Input or Internal Temperature) (Note 5)		–	11.38	12.06	ms
Conversion Time (External Temperature) (Note 5)		–	34.13	36.18	ms
Input Resistance (+5.0 V_{IN} , V_{CCP} , $A_{IN0} - A_{IN5}$)		80	100	120	kΩ
Input Resistance of +12 V_{IN} pin		70	100	115	kΩ
Input Resistance of –12 V_{IN} pin		8.0	10	12	kΩ
Input Resistance ($A_{IN6} - A_{IN9}$)		5.0	–	–	MΩ
Input Resistance of V_{BAT} pin (Note 4)		80	100	120	kΩ
V_{BAT} Current Drain (when measured)	CR2032 Battery Life >10 Years	–	80	100	nA
V_{BAT} Current Drain (when not measured)		–	6.0	–	nA
ANALOG OUTPUT (DAC)					
Output Voltage Range		0	–2.5	–	V
Total Unadjusted Error (TUE)	$I_L = 2$ mA	–	–	±5.0	%
Zero Error	No Load	–	1.0	–	LSB
Differential Non-linearity (DNL)	Monotonic by Design	–	–	±1.0	LSB
Integral Non-linearity		–	±0.5	–	LSB
Output Source Current		–	2.0	–	mA
Output Sink Current		–	1.0	–	mA
REFERENCE OUTPUT					
Output Voltage	Bit 2 of Register 07h = 0 Bit 2 of Register 07h = 1	1.8 2.47	1.82 2.50	1.84 2.53	V
Load Regulation ($I_{SINK} = 2$ mA)		–	0.15	–	%
Load Regulation ($I_{SOURCE} = 2$ mA)		–	0.15	–	%
Short Circuit Current	$V_{CC} = 3.3$ V	–	25	–	mA
Output Current Source		–	2.0	–	mA
Output Current Sink		–	2.0	–	mA

ADM1026

Table 4. ELECTRICAL CHARACTERISTICS ($T_A = T_{MIN}$ to T_{MAX} , $V_{CC} = V_{MIN}$ to V_{MAX} , unless otherwise noted. (Note 1, 2, and 3))

Parameter	Test Conditions/Comments	Min	Typ	Max	Unit
FAN RPM-TO-DIGITAL CONVERTER (Note 6)					
Accuracy		–	–	±12	%
Full-scale Count		–	–	255	
FAN0 to FAN7 Nominal Input RPM (Note 5)	Divisor = 1, fan count = 153 Divisor = 2, fan count = 153 Divisor = 4, fan count = 153 Divisor = 8, fan count = 153	–	8800 4400 2200 1100	–	RPM
Internal Clock Frequency		20	22.5	25	kHz
OPEN DRAIN O/Ps, PWM, GPIO0 to 16					
Output High Voltage, V_{OH}	$I_{OUT} = 3.0\text{ mA}$, $V_{CC} = 3.3\text{ V}$	2.4	–	–	V
High Level Output Leakage Current, I_{OH}	$V_{OUT} = V_{CC}$	–	0.1	1.0	μA
Output Low Voltage, V_{OL}	$I_{OUT} = -3.0\text{ mA}$, $V_{CC} = 3.3\text{ V}$	–	–	0.4	V
PWM Output Frequency		–	75	–	Hz
DIGITAL OUTPUTS (INT, RESETMAIN, RESETSBY)					
Output Low Voltage, V_{OL}	$I_{OUT} = -3.0\text{ mA}$, $V_{CC} = 3.3\text{ V}$	–	–	0.4	V
RESET Pulse Width		140	180	240	ms
OPEN DRAIN SERIAL DATABUS OUTPUT (SDA)					
Output Low Voltage, V_{OL}	$I_{OUT} = -3.0\text{ mA}$, $V_{CC} = 3.3\text{ V}$	–	–	0.4	V
High Level Output Leakage Current, I_{OH}	$V_{OUT} = V_{CC}$	–	0.1	1.0	μA
SERIAL BUS DIGITAL INPUTS (SCL, SDA)					
Input High Voltage, V_{IH}		2.2	–	–	V
Input Low Voltage, V_{IL}		–	–	0.8	V
Hysteresis		–	500	–	mV
DIGITAL INPUT LOGIC LEVELS (ADD, CI, FAN 0 to 7, GPIO 0 to 16) (Note 7 and 8)					
Input High Voltage, V_{IH}	$V_{CC} = 3.3\text{ V}$	2.4	–	–	V
Input Low Voltage, V_{IL}	$V_{CC} = 3.3\text{ V}$	0.8	–	–	V
Hysteresis (Fan 0 to 7)	$V_{CC} = 3.3\text{ V}$	–	250	–	mV
RESETMAIN, RESETSBY					
RESETMAIN Threshold	Falling Voltage	2.89	2.94	2.97	V
RESETSBY Threshold	Falling Voltage	3.01	3.05	3.10	V
RESETMAIN Hysteresis		–	60	–	mV
RESETSBY Hysteresis		–	70	–	mV
DIGITAL INPUT CURRENT					
Input High Current, I_{IH}	$V_{IN} = V_{CC}$	–1.0	–	–	μA
Input Low Current, I_{IL}	$V_{IN} = 0$	–	–	1.0	μA
Input Capacitance, C_{IN}		–	20	–	pF
EEPROM RELIABILITY					
Endurance (Note 9)		100	700	–	kcycles
Data Retention (Note 10)		10	–	–	Years
SERIAL BUS TIMING					
Clock Frequency, f_{SCLK}	See Figure 2 for All Parameters.	–	–	400	kHz
Glitch Immunity, t_{SW}		–	–	50	ns
Bus Free Time, t_{BUF}		4.7	–	–	μs
Start Setup Time, t_{SU} ; STA		4.7	–	–	μs

ADM1026

Table 4. ELECTRICAL CHARACTERISTICS ($T_A = T_{MIN}$ to T_{MAX} , $V_{CC} = V_{MIN}$ to V_{MAX} , unless otherwise noted. (Note 1, 2, and 3))

Parameter	Test Conditions/Comments	Min	Typ	Max	Unit
SERIAL BUS TIMING					
Start Hold Time, $t_{HD; STA}$		4.0	–	–	μs
SCL Low Time, t_{LOW}		4.7	–	–	μs
SCL High Time, t_{HIGH}		4.0	–	–	μs
SCL, SDA Rise Time, t_r		–	–	1000	ns
SCL, SDA Fall Time, t_f		–	–	300	ns
Data Setup Time, $t_{SU; DAT}$		250	–	–	ns
Data Hold Time, $t_{HD; DAT}$		300	–	–	ns

1. All voltages are measured with respect to GND, unless otherwise specified.
2. Typicals are at $T_A = 25^\circ\text{C}$ and represent the most likely parametric norm. Shutdown current typ is measured with $V_{CC} = 3.3\text{ V}$.
3. Timing specifications are tested at logic levels of $V_{IL} = 0.8\text{ V}$ for a falling edge and $V_{IH} = 2.1\text{ V}$ for a rising edge.
4. Total unadjusted error (TUE) includes offset, gain, and linearity errors of the ADC, multiplexer, and on-chip input attenuators. V_{BAT} is accurate only for V_{BAT} voltages greater than 1.5 V (see Figure 14).
5. Total analog monitoring cycle time is nominally 273 ms, made up of $18\text{ ms} \times 11.38\text{ ms}$ measurements on analog input and internal temperature channels, and $2\text{ ms} \times 34.13\text{ ms}$ measurements on external temperature channels.
6. The total fan count is based on two pulses per revolution of the fan tachometer output. The total fan monitoring time depends on the number of fans connected and the fan speed. See the Fan Speed Measurement section for more details.
7. ADD is a three-state input that may be pulled high, low, or left open circuit.
8. Logic inputs accept input high voltages up to 5.0 V even when device is operating at supply voltages below 5.0 V.
9. Endurance is qualified to 100,000 cycles as per JEDEC Std. 22 method A117, and measured at -40°C , $+25^\circ\text{C}$, and $+85^\circ\text{C}$. Typical endurance at $+25^\circ\text{C}$ is 700,000 cycles.
10. Retention lifetime equivalent at junction temperature (T_J) = 55°C as per JEDEC Std. 22 method A117. Retention lifetime based on activation energy of 0.6 V derates with junction temperature as shown in Figure 15.

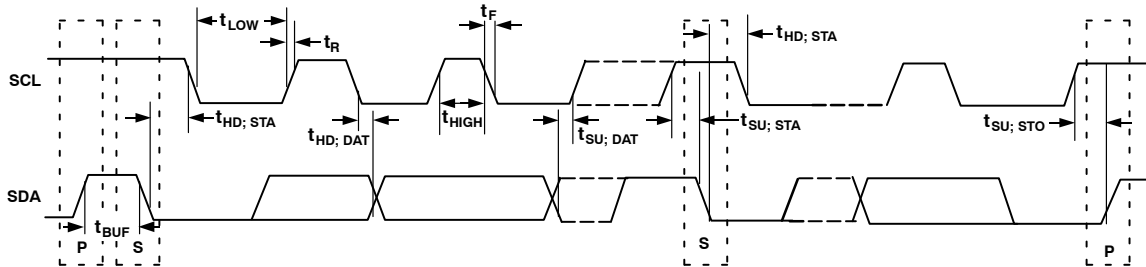

Figure 2. Serial Bus Timing Diagram

TYPICAL PERFORMANCE CHARACTERISTICS

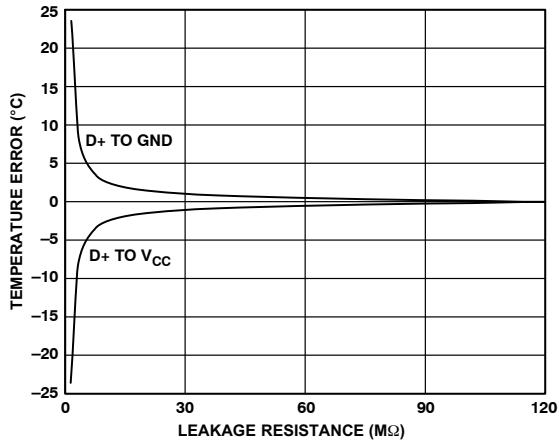

Figure 3. Temperature Error vs. PCB Track Resistance

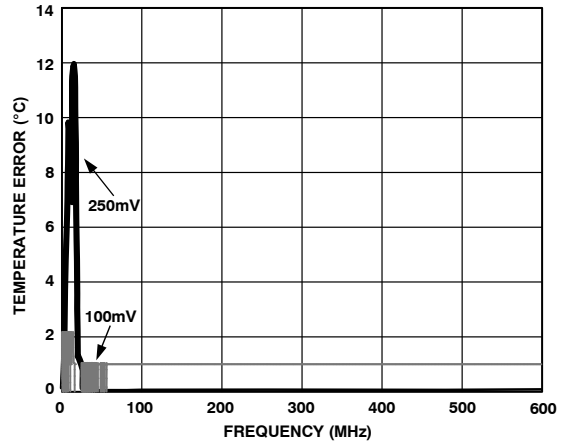

Figure 4. Temperature Error vs. Power Supply Noise Frequency

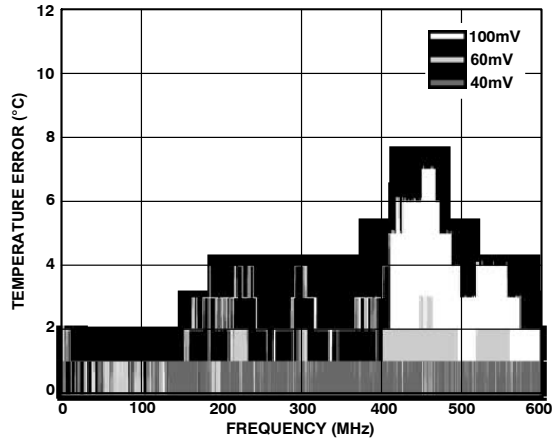

Figure 5. Temperature Error vs. Common-mode Noise Frequency

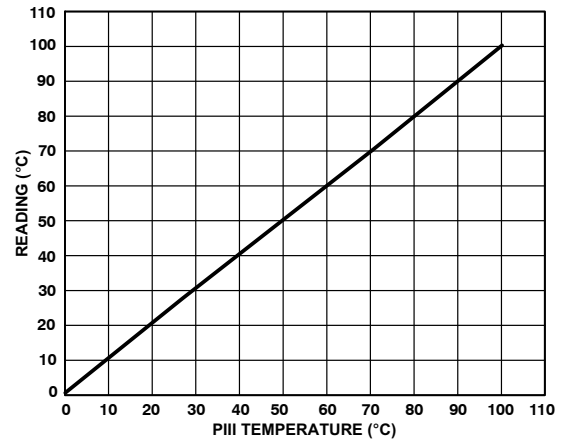

Figure 6. Pentium® III Temperature vs. ADM1026 Reading

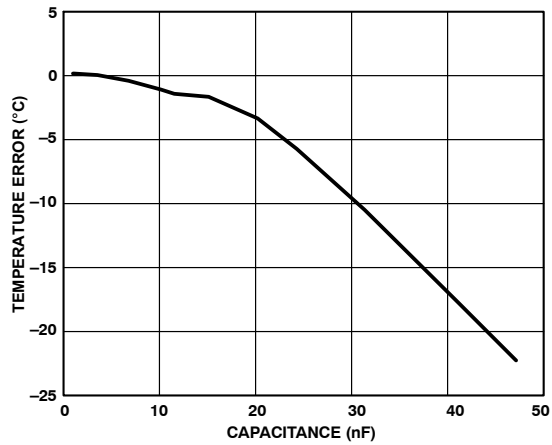

Figure 7. Temperature Error vs. Capacitance Between D+ and D-

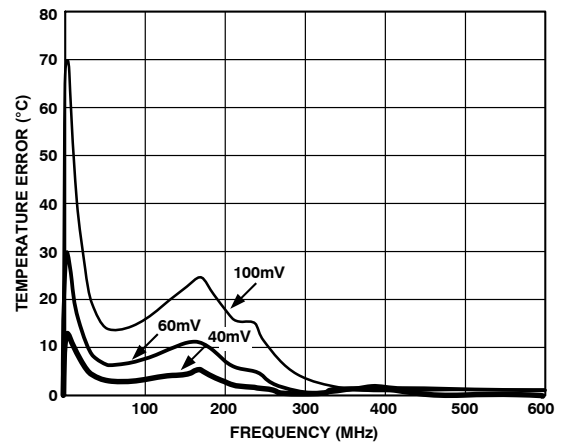

Figure 8. Temperature Error vs. Differential-mode Noise Frequency

TYPICAL PERFORMANCE CHARACTERISTICS

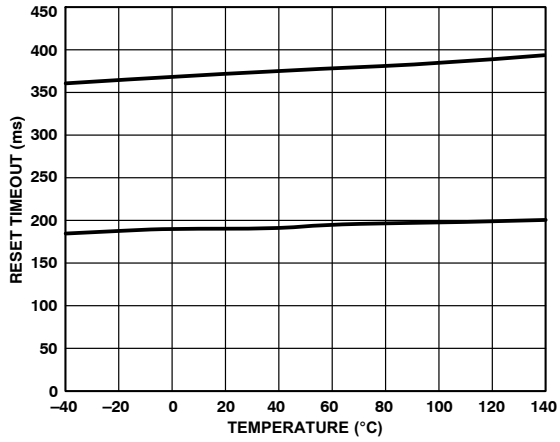

Figure 9. Powerup Reset Timeout vs. Temperature

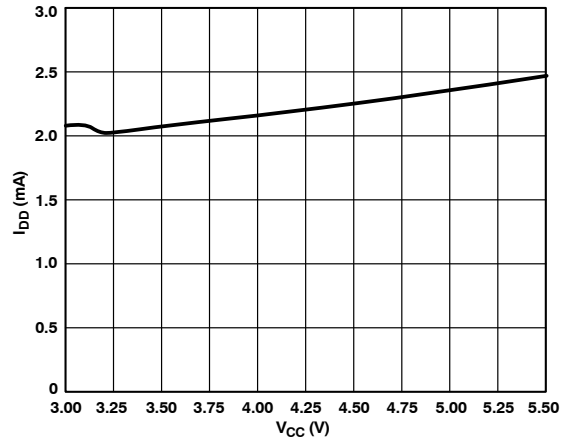

Figure 10. Supply Current vs. Supply Voltage

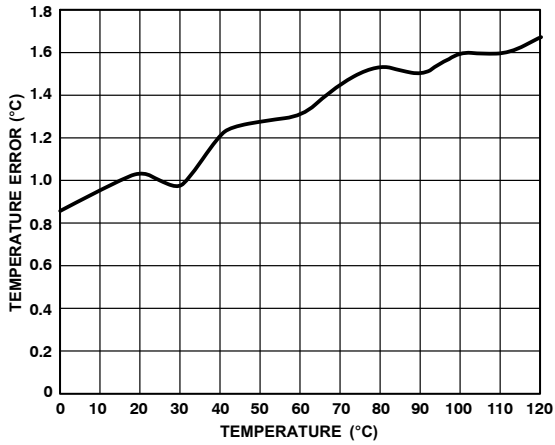

Figure 11. Local Sensor Temperature Error

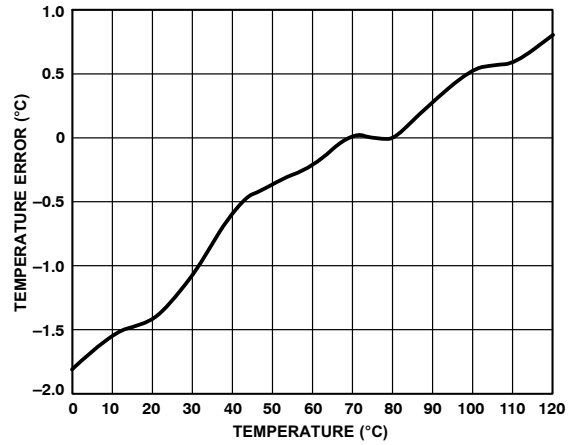

Figure 12. Remote Sensor Temperature Error

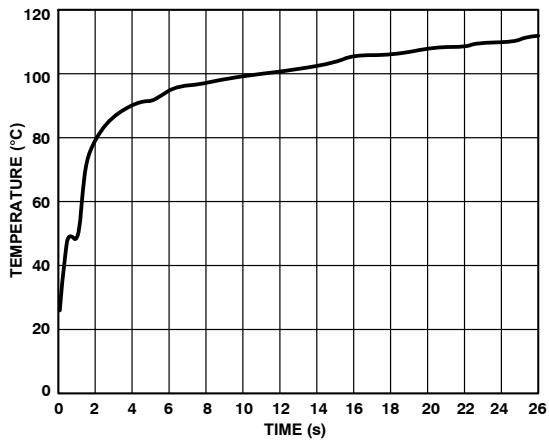

Figure 13. Response to Thermal Shock

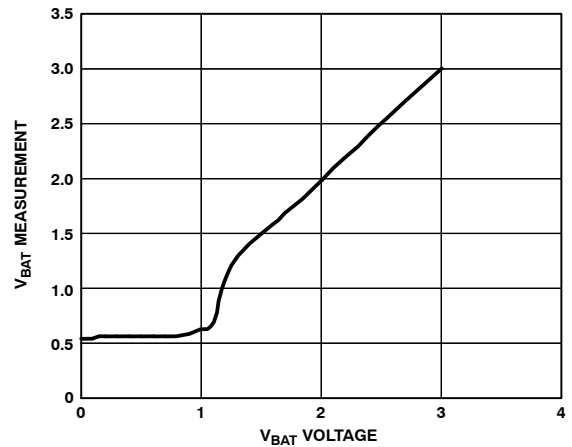

Figure 14. V_{BAT} Measurement vs. Voltage

Functional Description

The ADM1026 is a complete system hardware monitor for microprocessor-based systems. The device communicates with the system via a serial system management bus. The serial bus controller has a hardwired address line for device selection (ADD, Pin 15), a serial data line for reading and writing addresses and data (SDA, Pin 14), and an input line for the serial clock (SCL, Pin 13). All control and programming functions of the ADM1026 are performed over the serial bus.

Measurement Inputs

Programmability of the analog and digital measurement inputs makes the ADM1026 extremely flexible and versatile. The device has an 8-bit A/D converter, and 17 analog measurement input pins that can be configured in different ways.

Pins 25 and 26 are dedicated temperature inputs and may be connected to the cathode and anode of a remote temperature sensing diode.

Pins 27 and 28 may be configured as temperature inputs and connected to a second temperature-sensing diode, or may be reconfigured as analog inputs with a range of 0 V to 2.5 V.

Pins 29 to 33 are dedicated analog inputs with on-chip attenuators configured to monitor V_{BAT} , +5.0 V, -12 V, +12 V, and the processor core voltage V_{CCP} , respectively.

Pins 34 to 41 are general-purpose analog inputs with a range of 0 V to 2.5 V or 0 V to 3.0 V. These are mainly intended for monitoring SCSI termination voltages, but may be used for other purposes.

The ADC also accepts input from an on-chip band gap temperature sensor that monitors system ambient temperature.

In addition, the ADM1026 monitors the supply from which it is powered, 3.3 V STBY, so there is no need for a separate pin to monitor the power supply voltage.

The ADM1026 has eight pins that are general-purpose logic I/O pins (Pins 1, 2, and 43 to 48), a pin that can be configured as GPIO or as a bidirectional thermal interrupt (THERM) pin (Pin 42), and eight pins that can be configured for fan speed measurement or as general-purpose logic pins (Pins 3 to 6 and Pins 9 to 12).

Sequential Measurement

When the ADM1026 monitoring sequence is started, it cycles sequentially through the measurement of analog inputs and the temperature sensor, while at the same time the fan speed inputs are independently monitored. Measured values from these inputs are stored in value registers. These can be read over the serial bus, or can be compared with programmed limits stored in the limit registers. The results of out-of-limit comparisons are stored in the interrupt status registers. An out-of-limit event generates an interrupt on the INT line (Pin 17).

Any or all of the interrupt status bits can be masked by appropriate programming of the interrupt mask registers.

Chassis Intrusion

A chassis intrusion input (Pin 16) is provided to detect unauthorized tampering with the equipment. This event is latched in a battery-backed register bit.

Resets

The ADM1026 has two power-on reset outputs, $\overline{\text{RESETMAIN}}$ and $\overline{\text{RESETSTBY}}$, that are asserted when 3.3 V MAIN or 3.3 V STBY fall below the reset threshold. These give a 180 ms reset pulse at powerup. $\overline{\text{RESETMAIN}}$ also functions as an active-low RESET input.

Fan Speed Control Outputs

The ADM1026 has two outputs intended to control fan speed, though they can also be used for other purposes. Pin 18 is an open drain, Pulse Width Modulated (PWM) output with a programmable duty cycle and an output frequency of 75 Hz. Pin 23 is connected to the output of an on-chip, 8-bit, digital-to-analog converter with an output range of 0 V to 2.5 V.

Either or both of these outputs may be used to implement a temperature-controlled fan by controlling the speed of a fan using the temperature measured by the on-chip temperature sensor or remote temperature sensors.

Internal Registers

Table 5 describes the principal registers of the ADM1026. For more detailed information, see Table 12 to Table 125.

Table 5. PRINCIPLE REGISTERS

Type	Description
Address Pointer	Contains the address that selects one of the other internal registers. When writing to the ADM1026, the first byte of data is always a register address, and is written to the address pointer register.
Configuration Registers	Provide control and configuration for various operating parameters.
Fan Divisor Registers	Contain counter prescaler values for fan speed measurement.
DAC/PWM Control Registers	Contain speed values for PWM and DAC fan drive outputs.
GPIO Configuration Registers	Configure the GPIO pins as input or output and for signal polarity.
Value and Limit Registers	Store the results of analog voltage inputs, temperature, and fan speed measurements, along with their limit values.
Status Registers	Store events from the various interrupt sources.
Mask Registers	Allow masking of individual interrupt sources.

EEPROM

The ADM1026 has 8 kB of non-volatile, electrically erasable, programmable read-only memory (EEPROM) from register Addresses 8000h to 9FFFh. This may be used for permanent storage of data that is not lost when the

ADM1026 is powered down, unlike the data in the volatile registers. Although referred to as read-only memory, the EEPROM can be written to (as well as read from) via the serial bus in exactly the same way as the other registers. The main differences between the EEPROM and other registers are:

- An EEPROM location must be blank before it can be written to. If it contains data, it must first be erased.
- Writing to EEPROM is slower than writing to RAM.
- Writing to the EEPROM should be restricted because its typical cycle life is 100,000 write operations, due to the usual EEPROM wear-out mechanisms.

The EEPROM in the ADM1026 has been qualified for two key EEPROM memory characteristics: memory cycling endurance and memory data retention.

Endurance qualifies the ability of the EEPROM to be cycled through many program, read, and erase cycles. In real terms, a single endurance cycle is composed of four independent, sequential events, as follows:

1. Initial page erase sequence
2. Read/verify sequence
3. Program sequence
4. Second read/verify sequence

In reliability qualification, every byte is cycled from 00h to FFh until a first fail is recorded, signifying the endurance limit of the EEPROM memory.

Retention quantifies the ability of the memory to retain its programmed data over time. The EEPROM in the ADM1026 has been qualified in accordance with the formal JEDEC Retention Lifetime Specification (A117) at a specific junction temperature ($T_J = 55^\circ\text{C}$) to guarantee a minimum of 10 years retention time. As part of this qualification procedure, the EEPROM memory is cycled to its specified endurance limit described above before data retention is characterized. This means that the EEPROM memory is guaranteed to retain its data for its full specified retention lifetime every time the EEPROM is reprogrammed. Note that retention lifetime based on an activation energy of 0.6 V derates with T_J , as shown in Figure 15.

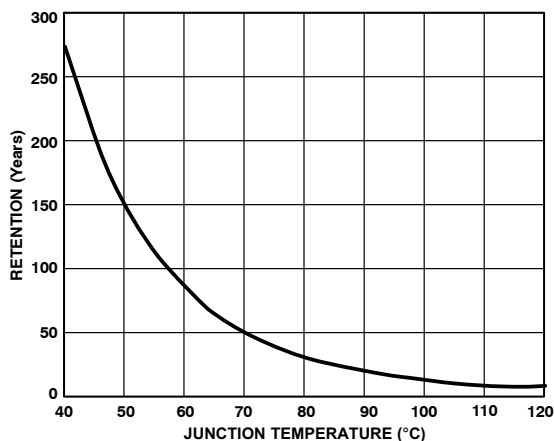

Figure 15. Typical EEPROM Memory Retention

Serial Bus Interface

Control of the ADM1026 is carried out via the serial system management bus (SMBus). The ADM1026 is connected to this bus as a slave device, under the control of a master device.

The ADM1026 has a 7-bit serial bus slave address. When the device is powered on, it does so with a default serial bus address. The 5 MSBs of the address are set to 01011, and the 2 LSBs are determined by the logical states of Pin 15 ADD/NTESTOUT. This pin is a three-state input that can be grounded, connected to V_{CC} , or left open-circuit to give three different addresses.

Table 6. ADDRESS PIN TRUTH TABLE

ADD Pin	A1	A0
GND	0	0
No Connect	1	0
V_{CC}	0	1

If ADD is left open-circuit, the default address is 0101110 (5Ch). ADD is sampled only at powerup on the first valid SMBus transaction, so any changes made while the power is on (and the address is locked) have no effect.

The facility to make hardwired changes to device addresses allows the user to avoid conflicts with other devices sharing the same serial bus, for example if more than one ADM1026 is used in a system.

General SMBus Timing

Figure 16 and Figure 17 show timing diagrams for general read and write operations using the SMBus. The SMBus specification defines specific conditions for different types of read and write operations, which are discussed later in this section. The general SMBus protocol* operates as follows:

1. The master initiates data transfer by establishing a start condition, defined as a high-to-low transition on the serial data line (SDA) while the serial clock line SCL remains high. This indicates that a data stream follows. All slave peripherals connected to the serial bus respond to the start condition and shift in the next 8 bits, consisting of a 7-bit slave address (MSB first) and an R/\overline{W} bit, which determine the direction of the data transfer, that is, whether data is written to or read from the slave device (0 = write, 1 = read).

The peripheral whose address corresponds to the transmitted address responds by pulling the data line low during the low period before the ninth clock pulse, known as the acknowledge bit, and holding it low during the high period of this clock pulse. All other devices on the bus remain idle while the selected device waits for data to be read from or written to it. If the R/\overline{W} bit is 0, the master writes to the slave device. If the R/\overline{W} bit is 1, the master reads from the slave device.

2. Data is sent over the serial bus in sequences of nine clock pulses, 8 bits of data followed by an acknowledge bit from the slave device. Data transitions on the data line must occur during the low period of the clock signal and remain stable during the high period, because a low-to-high transition when the clock is high may be interpreted as a stop signal.

If the operation is a write operation, the first data byte after the slave address is a command byte. This tells the slave device what to expect next. It may be an instruction telling the slave device to expect a block write, or it may simply be a register address that tells the slave where subsequent data is to be written.

Because data can flow in only one direction as defined by the R/\bar{W} bit, it is not possible to send a command to a slave device during a read operation.

Before doing a read operation, it may first be necessary to do a write operation to tell the slave what type of read operation to expect and/or the address from which data is to be read.

3. When all data bytes have been read or written, stop conditions are established. In write mode, the master pulls the data line high during the 10th clock pulse to assert a stop condition. In read mode, the master device releases the SDA line during the low period before the ninth clock pulse, but the slave device does not pull it low (called No Acknowledge). The master takes the data line low during the low period before the 10th clock pulse, then high during the 10th clock pulse to assert a stop condition.

*If it is required to perform several read or write operations in succession, the master can send a repeat start condition instead of a stop condition to begin a new operation.

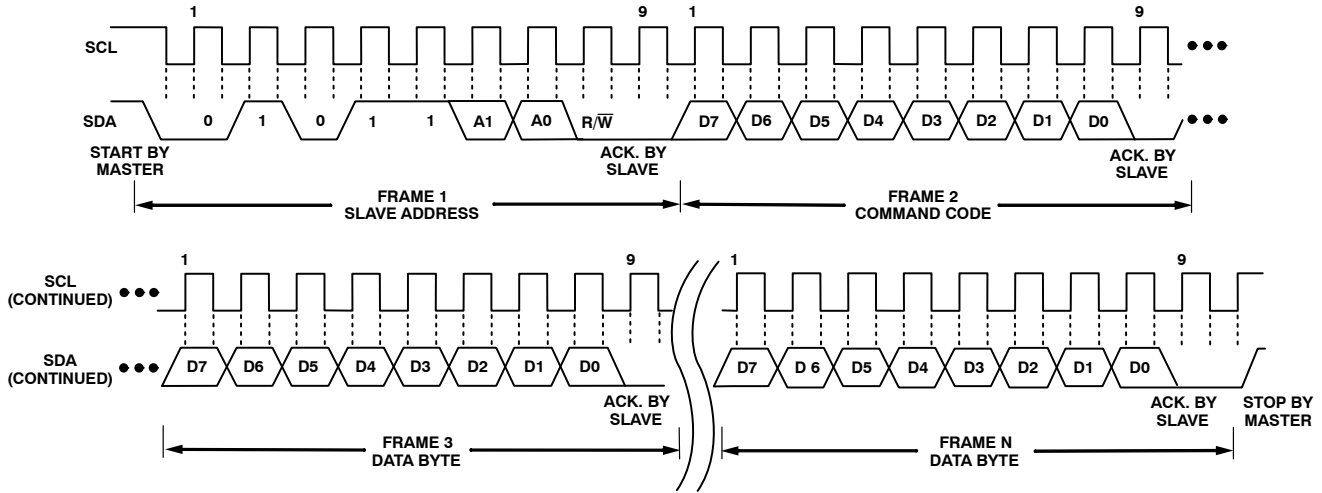

Figure 16. General SMBus Write Timing Diagram

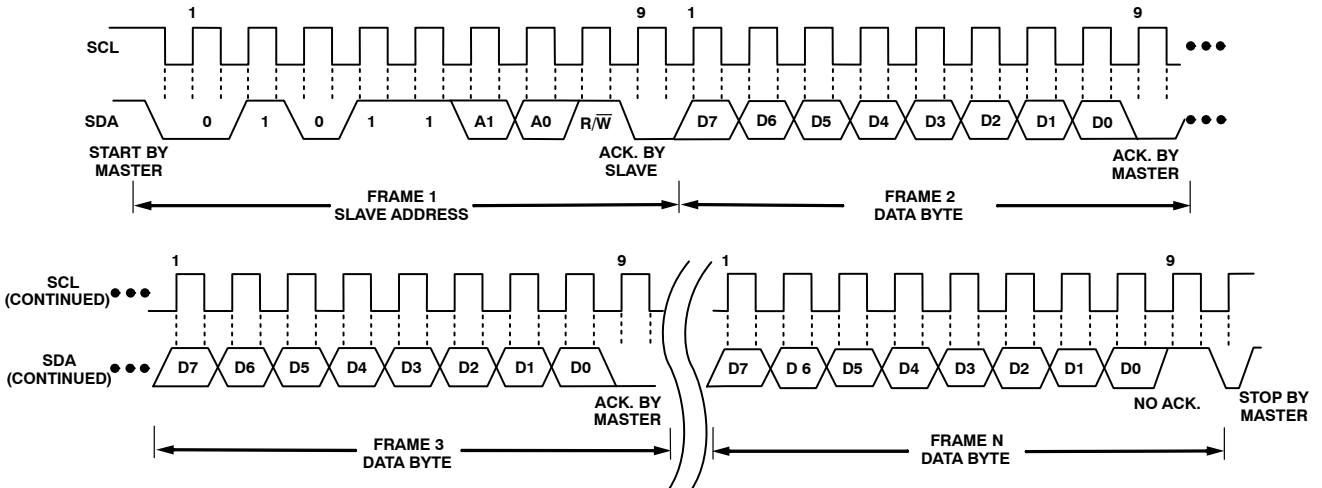

Figure 17. General SMBus Read Timing Diagram

SMBus Protocols for RAM and EEPROM

The ADM1026 contains volatile registers (RAM) and non-volatile EEPROM. RAM occupies Addresses 00h to 6Fh, while EEPROM occupies Addresses 8000h to 9FFFh.

Data can be written to and read from both RAM and EEPROM as single data bytes and as block (sequential) read or write operations of 32 data bytes, the maximum block size allowed by the SMBus specification.

Data can only be written to unprogrammed EEPROM locations. To write new data to a programmed location, it is first necessary to erase it. EEPROM erasure cannot be done at the byte level; the EEPROM is arranged as 128 pages of 64 bytes, and an entire page must be erased. Note that of these 128 pages, only 124 pages are available to the user. The last four pages are reserved for manufacturing purposes and cannot be erased/rewritten.

The EEPROM has three RAM registers associated with it, EEPROM Registers 1, 2, and 3 at Addresses 06h, 0Ch, and 13h. EEPROM Registers 1 and 2 are for factory use only. EEPROM Register 3 sets up the EEPROM operating mode. Setting Bit 0 of EEPROM Register 3 puts the EEPROM into read mode. Setting Bit 1 puts it into programming mode. Setting Bit 2 puts it into erase mode.

Only one of these bits must be set before the EEPROM may be accessed. Setting no bits or more than one of them causes the device to respond with No Acknowledge if an EEPROM read, program, or erase operation is attempted.

It is important to distinguish between SMBus write operations, such as sending an address or command, and EEPROM programming operations. It is possible to write an EEPROM address over the SMBus, whatever the state of EEPROM Register 3. However, EEPROM Register 3 must be correctly set before a subsequent EEPROM operation can be performed. For example, when reading from the EEPROM, Bit 0 of EEPROM Register 3 can be set, even though SMBus write operations are required to set up the EEPROM address for reading. Bit 3 of EEPROM Register 3 is used for EEPROM write protection. Setting this bit prevents accidental programming or erasure of the EEPROM. If an EEPROM write or erase operation is attempted when this bit is set, the ADM1026 responds with No Acknowledge. This bit is write-once and can only be cleared by a power-on reset.

EEPROM Register 3 Bit 7 is used for clock extend. Programming an EEPROM byte takes approximately 250 μ s, which would limit the SMBus clock for repeated or block write operations. Because EEPROM block read/write access is slow, it is recommended that this clock extend bit typically be set to 1. This allows the ADM1026 to pull SCL low and extend the clock pulse when it cannot accept any more data.

ADM1026 SMBus Operations

The SMBus specifications define several protocols for different types of read and write operations. The ones used in the ADM1026 are discussed below. The following abbreviations are used in the diagrams:

- S – START
- W – WRITE
- P – STOP
- A – ACKNOWLEDGE
- R – READ
- \bar{A} – NO ACKNOWLEDGE

ADM1026 Write Operations

Send Byte

In this operation, the master device sends a single command byte to a slave device, as follows:

1. The master device asserts a start condition on the SDA.
2. The master sends the 7-bit slave address followed by the write bit (low).
3. The addressed slave device asserts an ACK on the SDA.
4. The master sends a command code.
5. The slave asserts ACK on the SDA.
6. The master asserts a stop condition on the SDA and the transaction ends.

In the ADM1026, the send byte protocol is used to write a register address to RAM for a subsequent single-byte read from the same address or block read or write starting at that address. This is illustrated in Figure 18.

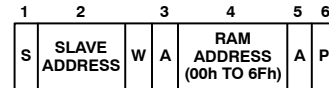

Figure 18. Setting a RAM Address for Subsequent Read

If it is required to read data from the RAM immediately after setting up the address, the master can assert a repeat start condition immediately after the final ACK and carry out a single byte read, block read, or block write operation without asserting an intermediate stop condition.

Write Byte/Word

In this operation, the master device sends a command byte and one or two data bytes to the slave device as follows:

1. The master device asserts a start condition on the SDA.
2. The master sends the 7-bit slave address followed by the write bit (low).
3. The addressed slave device asserts an ACK on the SDA.
4. The master sends a command code.
5. The slave asserts an ACK on the SDA.
6. The master sends a data byte.
7. The slave asserts an ACK on the SDA.
8. The master sends a data byte (or may assert stop here.)
9. The slave asserts an ACK on the SDA.
10. The master asserts a stop condition on the SDA to end the transaction.

In the ADM1026, the write byte/word protocol is used for four purposes. The ADM1026 knows how to respond by the value of the command byte and EEPROM Register 3.

The first purpose is to write a single byte of data to RAM. In this case, the command byte is the RAM address from 00h to 6Fh and the (only) data byte is the actual data. This is illustrated in Figure 19.

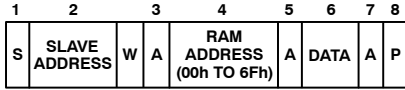

Figure 19. Single Byte Write to RAM

The protocol is also used to set up a 2-byte EEPROM address for a subsequent read or block read. In this case, the command byte is the high byte of the EEPROM address from 80h to 9Fh. The (only) data byte is the low byte of the EEPROM address. This is illustrated in Figure 20.

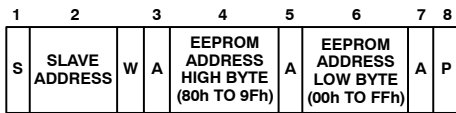

Figure 20. Setting an EEPROM Address

If it is required to read data from the EEPROM immediately after setting up the address, the master can assert a repeat start condition immediately after the final ACK and carry out a single-byte read or block read operation without asserting an intermediate stop condition. In this case, Bit 0 of EEPROM Register 3 should be set.

The third use is to erase a page of EEPROM memory. EEPROM memory can be written to only if it is previously erased. Before writing to one or more EEPROM memory locations that are already programmed, the page or pages containing those locations must first be erased. EEPROM memory is erased by writing an EEPROM page address plus an arbitrary byte of data with Bit 2 of EEPROM Register 3 set to 1.

Because the EEPROM consists of 128 pages of 64 bytes, the EEPROM page address consists of the EEPROM address high byte (from 80h to 9Fh) and the two MSBs of the low byte. The lower six bits of the EEPROM address (low byte only) specify addresses within a page and are ignored during an erase operation.

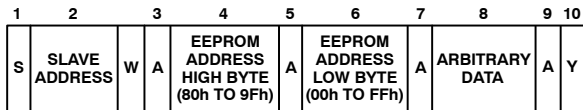

Figure 21. EEPROM Page Erasure

Page erasure takes approximately 20 ms. If the EEPROM is accessed before erasure is complete, the ADM1026 responds with No Acknowledge.

Last, this protocol is used to write a single byte of data to EEPROM. In this case, the command byte is the high byte of the EEPROM address from 80h to 9Fh. The first data byte is the low byte of the EEPROM address, and the second data

byte is the actual data. Bit 1 of EEPROM Register 3 must be set. This is illustrated in Figure 22.

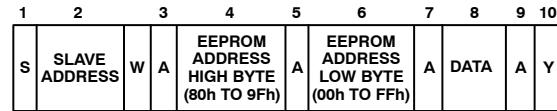

Figure 22. Single-Byte Write to EEPROM

Block Write

In this operation, the master device writes a block of data to a slave device. The start address for a block write must have been set previously. In the case of the ADM1026, this is done by a Send Byte operation to set a RAM address or by a write byte/word operation to set an EEPROM address.

1. The master device asserts a start condition on the SDA.
2. The master sends the 7-bit slave address followed by the write bit (low).
3. The addressed slave device asserts an ACK on the SDA.
4. The master sends a command code that tells the slave device to expect a block write. The ADM1026 command code for a block write is A0h (10100000).
5. The slave asserts an ACK on the SDA.
6. The master sends a data byte (20h) that tells the slave device that 32 data bytes are being sent to it. The master should always send 32 data bytes to the ADM1026.
7. The slave asserts an ACK on the SDA.
8. The master sends 32 data bytes.
9. The slave asserts an ACK on the SDA after each data byte.
10. The master sends a packet error checking (PEC) byte.
11. The ADM1026 checks the PEC byte and issues an ACK if correct. If incorrect (NACK), the master resends the data bytes.
12. The master asserts a stop condition on the SDA to end the transaction.

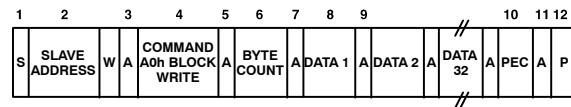

Figure 23. Block Write to EEPROM or RAM

When performing a block write to EEPROM, Bit 1 of EEPROM Register 3 must be set. Unlike some EEPROM devices that limit block writes to within a page boundary, there is no limitation on the start address when performing a block write to EEPROM, except:

- There must be at least 32 locations from the start address to the highest EEPROM address (9FF) to avoid writing to invalid addresses.
- If the addresses cross a page boundary, both pages must be erased before programming.

ADM1026 Read Operations

The ADM1026 uses the SMBus read protocols described here.

Receive Byte

In this operation, the master device receives a single byte from a slave device as follows:

1. The master device asserts a start condition on the SDA.
2. The master sends the 7-bit slave address followed by the read bit (high).
3. The addressed slave device asserts an ACK on the SDA.
4. The master receives a data byte.
5. The master asserts a NO ACK on the SDA.
6. The master asserts a stop condition on the SDA to end the transaction.

In the ADM1026, the receive byte protocol is used to read a single byte of data from a RAM or EEPROM location whose address has previously been set by a send byte or write byte/word operation. Figure 24 shows this. When reading from EEPROM, Bit 0 of EEPROM Register 3 must be set.

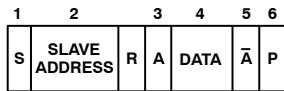

Figure 24. Single-Byte Read from EEPROM or RAM

Block Read

In this operation, the master device reads a block of data from a slave device. The start address for a block read must have been set previously. In the case of the ADM1026 this is done by a send byte operation to set a RAM address, or by a write byte/word operation to set an EEPROM address. The block read operation consists of a send byte operation that sends a block read command to the slave, immediately followed by a repeated start and a read operation that reads out multiple data bytes as follows:

1. The master device asserts a start condition on the SDA.
2. The master sends the 7-bit slave address followed by the write bit (low).
3. The addressed slave device asserts an ACK on the SDA.
4. The master sends a command code that tells the slave device to expect a block read. The ADM1026 command code for a block read is A 1h (10100001).
5. The slave asserts an ACK on the SDA.
6. The master asserts a repeat start condition on the SDA.
7. The master sends the 7-bit slave address followed by the read bit (high).
8. The slave asserts an ACK on the SDA.
9. The ADM1026 sends a byte count data byte that tells the master how many data bytes to expect. The

- ADM1026 always returns 32 data bytes (20h), the maximum allowed by the SMBus 1.1 specification.
10. The master asserts an ACK on the SDA.
11. The master receives 32 data bytes.
12. The master asserts an ACK on the SDA after each data byte.
13. The ADM1026 issues a PEC byte to the master. The master should check the PEC byte and issue another block read if the PEC byte is incorrect.
14. A NACK is generated after the PEC byte to signal the end of the read.
15. The master asserts a stop condition on the SDA to end the transaction.

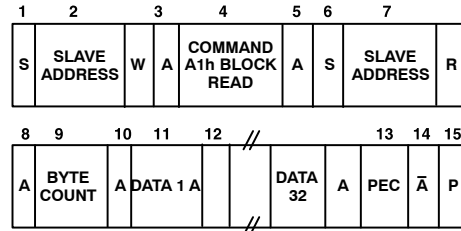

Figure 25. Block Read from EEPROM or RAM

When block reading from EEPROM, Bit 0 of EEPROM Register 3 must be set.

Note that although the ADM1026 supports Packet Error Checking (PEC), its use is optional. The PEC byte is calculated using CRC-8. The Frame Check Sequence (FCS) conforms to CRC-8 by the polynomial:

$$C(x) = x^8 + x^2 + x + 1 \quad (\text{eq. 1})$$

Consult the SMBus 1.1 Specification for more information.

Measurement Inputs

The ADM1026 has 17 external analog measurement pins that can be configured to perform various functions. It also measures two supply voltages, 3.3 V MAIN and 3.3 V STBY, and the internal chip temperature.

Pins 25 and 26 are dedicated to remote temperature measurement, while Pins 27 and 28 can be configured as analog inputs with a range of 0 V to 2.5 V, or as inputs for a second remote temperature sensor.

Pins 29 to 33 are dedicated to measuring V_{BAT} , +5.0 V, -12 V, +12 V supplies, and the processor core voltage V_{CCP} . The remaining analog inputs, Pins 34 to 41, are general-purpose analog inputs with a range of 0 V to 2.5 V (Pins 34 and 35) or 0 V to 3.0 V (Pins 36 to 41).

A-to-D Converter (ADC)

These inputs are multiplexed into the on-chip, successive approximation, analog-to-digital converter. The ADC has a resolution of 8 bits. The basic input range is 0 V to 2.5 V, which is the input range of A_{IN6} to A_{IN9} , but five of the inputs have built-in attenuators to allow measurement of V_{BAT} , +5.0 V, -12 V, +12 V, and the processor core voltage V_{CCB} without any external components. To allow the tolerance of these supply voltages, the ADC produces an

ADM1026

output of 3/4 full scale (decimal 192) for the nominal input voltage, and so has adequate headroom to cope with over voltages. Table 7 shows the input ranges of the analog inputs and output codes of the ADC.

When the ADC is running, it samples and converts an analog or local temperature input every 711 μ s (typical value). Each input is measured 16 times and the measurements are

averaged to reduce noise, so the total conversion time for each input is 11.38 ms.

Measurements on the remote temperature (D1 and D2) inputs take 2.13 ms. These are also measured 16 times and are averaged, so the total conversion time for a remote temperature input is 34.13 ms.

Table 7. A-TO-D OUTPUT CODES VS. V_{IN}

Input Voltage								A-to-D Output	
+12 V_{IN}	-12 V_{IN}	+5.0 V_{IN}	3.3 V MAIN	V_{BAT}	V_{CCP}	$A_{IN(0-5)}$	$A_{IN(6-9)}$	Decimal	Binary
< 0.0625	< -15.928	< 0.026	< 0.0172	NA	< 0.012	< 0.012	< 0.010	0	00000000
0.062-0.125	-15.928-15.855	0.026-0.052	0.017-0.034	NA	0.012-0.023	0.012-0.023	0.010-0.019	1	00000001
0.125-0.187	-15.855-15.783	0.052-0.078	0.034-0.052	NA	0.023-0.035	0.023-0.035	0.019-0.029	2	00000010
0.188-0.250	-15.783-15.711	0.078-0.104	0.052-0.069	NA	0.035-0.047	0.035-0.047	0.029-0.039	3	00000011
0.250-0.313	-15.711-15.639	0.104-0.130	0.069-0.086	NA	0.047-0.058	0.047-0.058	0.039-0.049	4	00000100
0.313-0.375	-15.639-15.566	0.130-0.156	0.086-0.103	NA	0.058-0.070	0.058-0.070	0.049-0.058	5	00000101
0.375-0.438	-15.566-15.494	0.156-0.182	0.103-0.120	NA	0.070-0.082	0.070-0.082	0.058-0.068	6	00000110
0.438-0.500	-15.494-15.422	0.182-0.208	0.120-0.138	NA	0.082-0.094	0.082-0.094	0.068-0.078	7	00000111
0.500-0.563	-15.422-15.349	0.208-0.234	0.138-0.155	NA	0.094-0.105	0.094-0.105	0.078-0.087	8	00001000
-	-	-	-	-	-	-	-	-	-
-	-	-	-	-	-	-	-	-	-
4.000-4.063	-11.375-11.303	1.667-1.693	1.110-1.127	NA	0.750-0.780	0.750-0.780	0.625-0.635	64 (1/4 scale)	01000000
-	-	-	-	-	-	-	-	-	-
-	-	-	-	-	-	-	-	-	-
-	-	-	-	-	-	-	-	-	-
8.000-8.063	-6.750-6.678	3.333-3.359	2.000-2.016	2.000-2.016	1.500-1.512	1.500-1.512	1.250-1.260	128 (1/2 scale)	10000000
-	-	-	-	-	-	-	-	-	-
-	-	-	-	-	-	-	-	-	-
-	-	-	-	-	-	-	-	-	-
12.000-12.063	-2.125-2.053	5-5.026	3.330-3.347	3.000-3.016	2.250-2.262	2.250-2.262	1.875-1.885	192 (3/4 scale)	11000000
-	-	-	-	-	-	-	-	-	-
-	-	-	-	-	-	-	-	-	-
-	-	-	-	-	-	-	-	-	-
15.313-15.375	1.705-1.777	6.38-6.406	4.249-4.267	3.828-3.844	2.871-2.883	2.871-2.883	2.392-2.402	245	11110101
15.375-15.437	1.777-1.850	6.406-6.432	4.267-4.284	3.844-3.860	2.883-2.895	2.883-2.895	2.402-2.412	246	11110110
15.437-15.500	1.850-1.922	6.432-6.458	4.284-4.301	3.860-3.875	2.895-2.906	2.895-2.906	2.412-2.422	247	11110111
15.500-15.563	1.922-1.994	6.458-6.484	4.301-4.319	3.875-3.890	2.906-2.918	2.906-2.918	2.422-2.431	248	11111000
15.562-15.625	1.994-2.066	6.484-6.51	4.319-4.336	3.890-3.906	2.918-2.930	2.918-2.930	2.431-2.441	249	11111001
15.625-15.688	2.066-2.139	6.51-6.536	4.336-4.353	3.906-3.921	2.930-2.941	2.930-2.941	2.441-2.451	250	11111010
15.688-15.750	2.139-2.211	6.536-6.563	4.353-4.371	3.921-3.937	2.941-2.953	2.941-2.953	2.451-2.460	251	11111011
15.750-15.812	2.211-2.283	6.563-6.589	4.371-4.388	3.937-3.953	2.953-2.965	2.953-2.965	2.460-2.470	252	11111100
15.812-15.875	2.283-2.355	6.589-6.615	4.388-4.405	3.953-3.969	2.965-2.977	2.965-2.977	2.470-2.480	253	11111101
15.875-15.938	2.355-2.428	6.615-6.641	4.405-4.423	3.969-3.984	2.977-2.988	2.977-2.988	2.480-2.490	254	11111110
>15.938	>2.428	>6.634	>4.423	>3.984	>2.988	>2.988	>2.490	255	11111111

1. * V_{BAT} is not accurate for voltages under 1.5 V (see Figure 14).

Voltage Measurement Inputs

The internal structure for all the analog inputs is shown in Figure 26. Each input circuit consists of an input protection diode, an attenuator, plus a capacitor to form a first-order low-pass filter that gives each voltage measurement input immunity to high frequency noise. The -12 V input also has a resistor connected to the on-chip reference to offset the negative voltage range so that it is always positive and can be handled by the ADC. This allows most popular power supply voltages to be monitored directly by the ADM1026 without requiring any additional resistor scaling.

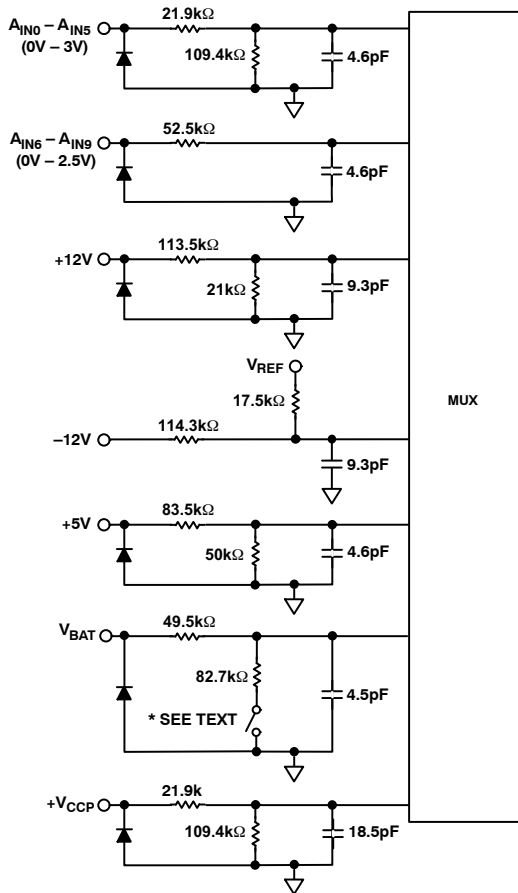

Figure 26. Voltage Measurement Inputs

Setting Other Input Ranges

A_{IN0} to A_{IN9} can easily be scaled to voltages other than 2.5 V or 3.0 V. If the input voltage range is zero to some positive voltage, all that is required is an input attenuator, as shown in Figure 27.

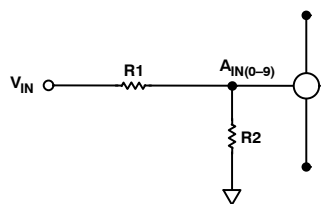

Figure 27. Scaling A_{IN0} - A_{IN9}

However, when scaling A_{IN0} to A_{IN5}, it should be noted that these inputs already have an on-chip attenuator, because their primary function is to monitor SCSI termination voltages. This attenuator loads any external attenuator. The input resistance of the on-chip attenuator can be between 100 kΩ and 200 kΩ. For this tolerance not to affect the accuracy, the output resistance of the external attenuator should be very much lower than this, that is, 1 kΩ in order to add not more than 1% to the total unadjusted error (TUE). Alternatively, the input can be buffered using an op amp.

$$\frac{R1}{R2} = \frac{(V_{fs} - 3.0)}{3.0} \text{ (for } A_{IN0} \text{ through } A_{IN5}) \quad \text{(eq. 2)}$$

$$\frac{R1}{R2} = \frac{(V_{fs} - 2.5)}{2.5} \text{ (for } A_{IN6} \text{ through } A_{IN9}) \quad \text{(eq. 3)}$$

Negative and bipolar input ranges can be accommodated by using a positive reference voltage to offset the input voltage range so that it is always positive. To monitor a negative input voltage, an attenuator can be used as shown in Figure 28.

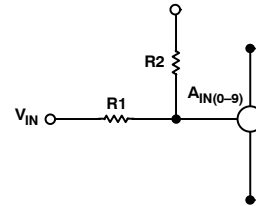

Figure 28. Scaling and Offsetting A_{IN0} - A_{IN9} for Negative Inputs

This offsets the negative voltage so that the ADC always sees a positive voltage. R1 and R2 are chosen so that the ADC input voltage is zero when the negative input voltage is at its maximum (most negative) value, that is:

$$\frac{R1}{R2} = \left| \frac{V_{fs}}{V_{OS}} \right| \quad \text{(eq. 4)}$$

This is a simple and low cost solution, but note the following:

- Because the input signal is offset but not inverted, the input range is transposed. An increase in the magnitude of the negative voltage (going more negative) causes the input voltage to fall and give a lower output code from the ADC. Conversely, a decrease in the magnitude of the negative voltage causes the ADC code to increase. The maximum negative voltage corresponds to zero output from the ADC. This means that the upper and lower limits are transposed.
- For the ADC output to be full scale when the negative voltage is zero, V_{OS} must be greater than the full-scale voltage of the ADC, because V_{OS} is attenuated by R1 and R2. If V_{OS} is equal to or less than the full-scale voltage of the ADC, the input range is bipolar but not necessarily symmetrical.

This is a problem only if the ADC output must be full scale when the negative voltage is zero.

Symmetrical bipolar input ranges can be accommodated easily by making V_{OS} equal to the full-scale voltage of the analog input, and by adding a third resistor to set the positive full scale.

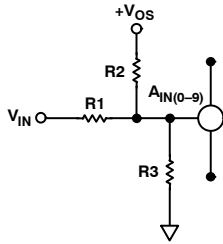

Figure 29. Scaling and Offsetting $A_{IN0} - A_{IN9}$ for Bipolar Inputs

$$\frac{R1}{R2} = \frac{|V_{fs}|}{V_{OS}} \quad (\text{eq. 5})$$

Note that R3 has no effect as the input voltage at the device pin is zero when $V_{IN} =$ negative full scale.

$$\frac{R1}{R3} = \frac{(V_{fs} - 3.0)}{3.0} \quad (\text{for } A_{IN0} \text{ through } A_{IN5}) \quad (\text{eq. 6})$$

$$\frac{R1}{R3} = \frac{(V_{fs} - 2.5)}{2.5} \quad (\text{for } A_{IN6} \text{ through } A_{IN9}) \quad (\text{eq. 7})$$

Also, note that R2 has no effect as the input voltage at the device pin is equal to V_{OS} when $V_{IN} =$ positive full scale.

Battery Measurement Input (V_{BAT})

The V_{BAT} input allows the condition of a CMOS backup battery to be monitored. This is typically a lithium coin cell such as a CR2032. The V_{BAT} input is accurate only for voltages greater than 1.5 V (see Figure 14). Typically, the battery in a system is required to keep some device powered on when the system is in a powered-off state. The V_{BAT} measurement input is specially designed to minimize battery drain. To reduce current drain from the battery, the lower resistor of the V_{BAT} attenuator is not connected, except whenever a V_{BAT} measurement is being made. The total current drain on the V_{BAT} pin is 80 nA typical (for a maximum V_{BAT} voltage = 4.0 V), so a CR2032 CMOS battery functions in a system in excess of the expected 10 years. Note that when a V_{BAT} measurement is not being made, the current drain is reduced to 6 nA typical. Under normal voltage measurement operating conditions, all measurements are made in a round-robin format, and each reading is actually the result of 16 digitally averaged measurements. However, averaging is not carried out on the V_{BAT} measurement to reduce measurement time and therefore reduce the current drain from the battery.

The V_{BAT} current drain when a measurement is being made is calculated by:

$$I = \frac{V_{BAT}}{100 \text{ k}\Omega} \times \frac{T_{PULSE}}{T_{PERIOD}} \quad (\text{eq. 8})$$

For example, when $V_{BAT} = 3.0 \text{ V}$,

$$I = \frac{3.0 \text{ V}}{100 \text{ k}\Omega} \times \frac{711 \mu\text{s}}{273 \text{ ms}} = 78 \text{ nA} \quad (\text{eq. 9})$$

where $T_{PULSE} = V_{BAT}$ measurement time (711 μs typical), $T_{PERIOD} =$ time to measure all analog inputs (273 ms typical), and V_{BAT} input battery protection.

V_{BAT} Input Battery Protection

In addition to minimizing battery current drain, the V_{BAT} measurement circuitry was specifically designed with battery protection in mind. Internal circuitry prevents the battery from being back-biased by the ADM1026 supply or through any other path under normal operating conditions. In the unlikely event of a catastrophic ADM1026 failure, the ADM1026 includes a second level of battery protection including a series 3 k Ω resistor to limit current to the battery, as recommended by UL. Thus, it is not necessary to add a series resistor between the battery and the V_{BAT} input; the battery can be connected directly to the V_{BAT} input to improve voltage measurement accuracy.

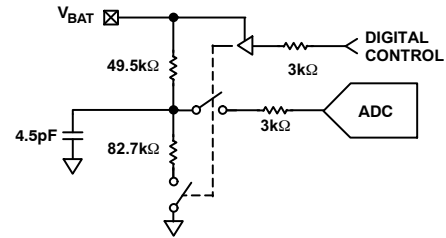

Figure 30. Equivalent V_{BAT} Input Protection Circuit

Reference Output (V_{REF})

The ADM1026 offers an on-chip reference voltage (Pin 24) that can be used to provide a 1.82 V or 2.5 V reference voltage output. This output is buffered and specified to sink or source a load current of 2 mA. The reference voltage outputs 1.82 V if Bit 2 of Configuration Register 3 (Address 07h) is 0; it outputs 2.5 V when this bit is set to 1. This voltage reference output can be used to provide a stable reference voltage to external circuitry such as LDOs. The load regulation of the V_{REF} output is typically 0.15% for a sink current of 2 mA and 0.15% for 2 mA source current. There may be some ripple present on the V_{REF} output that requires filtering ($\pm 4 \text{ m } V_{MAX}$). Figure 31 shows the recommended circuitry for the V_{REF} output for loads less than 2 mA. For loads in excess of 2 mA, external circuitry, such as that shown in Figure 32, can be used to buffer the V_{REF} output.

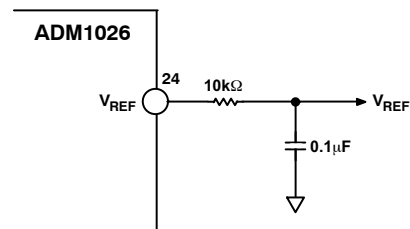

Figure 31. V_{REF} Interface Circuit for V_{REF} Loads < 2 mA

If the V_{REF} output is not being used, it should be left unconnected. Do not connect V_{REF} to GND using a capacitor. The internal output buffer on the voltage reference is capacitively loaded, which can cause the voltage reference to oscillate. This affects temperature readings reported back by the ADM1026. The recommended interface circuit for the V_{REF} output is shown in Figure 32.

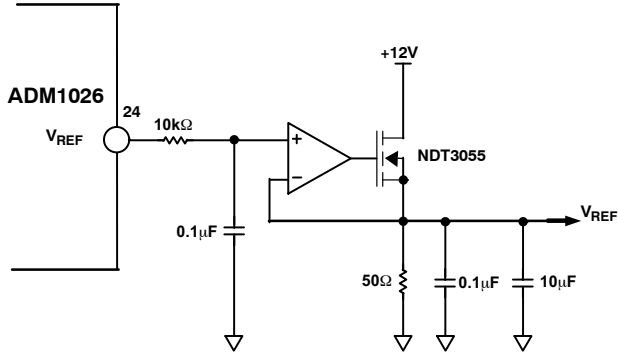

Figure 32. V_{REF} Interface Circuit for V_{REF} Loads > 2 mA

Temperature Measurement System

Local Temperature Measurement

The ADM1026 contains an on-chip band gap temperature sensor whose output is digitized by the on-chip ADC. The temperature data is stored in the local temperature value register (Address 1Fh). As both positive and negative temperatures can be measured, the temperature data is stored in twos complement format, as shown in Table 8. Theoretically, the temperature sensor and ADC can measure temperatures from -128°C to $+127^{\circ}\text{C}$ with a resolution of 1°C . Temperatures below T_{MIN} and above T_{MAX} are outside the operating temperature range of the device; however, so local temperature measurements outside this range are not possible. Temperature measurement from -128°C to $+127^{\circ}\text{C}$ is possible using a remote sensor.

Remote Temperature Measurement

The ADM1026 can measure the temperature of two remote diode sensors, or diode-connected transistors, connected to Pins 25 and 26, or 27 and 28.

Pins 25 and 26 are a dedicated temperature input channel. Pins 27 and 28 can be configured to measure a diode sensor

by clearing Bit 3 of Configuration Register 1 (Address 00h) to 0. If this bit is 1, then Pins 27 and 28 are A_{IN8} and A_{IN9} .

The forward voltage of a diode or diode-connected transistor, operated at a constant current, exhibits a negative temperature coefficient of about $-2\text{ mV}/^{\circ}\text{C}$. Unfortunately, the absolute value of V_{be} varies from device to device, and individual calibration is required to null this out, so the technique is unsuitable for mass production.

The technique used in the ADM1026 is to measure the change in V_{be} when the device is operated at two different currents, given by:

$$\Delta V_{be} = \frac{K \times T}{q} \times \log n(N) \quad (\text{eq. 10})$$

where K is Boltzmann's constant, q is the charge on the carrier, T is the absolute temperature in Kelvins, and N is the ratio of the two currents.

Figure 33 shows the input signal conditioning used to measure the output of a remote temperature sensor. This figure shows the external sensor as a substrate transistor provided for temperature monitoring on some microprocessors, but it could equally well be a discrete transistor such as a 2N3904.

If a discrete transistor is used, the collector is not grounded and should be linked to the base. If a PNP transistor is used, the base is connected to the D- input and the emitter to the D+ input. If an NPN transistor is used, the emitter is connected to the D- input and the base to the D+ input.

To prevent ground noise from interfering with the measurement, the more negative terminal of the sensor is not referenced to ground but is biased above ground by an internal diode at the D- input.

To measure ΔV_{be} , the sensor is switched between operating currents of I and $N \times I$. The resulting waveform is passed through a 65 kHz low-pass filter to remove noise, and to a chopper-stabilized amplifier that performs the functions of amplification and rectification of the waveform to produce a DC voltage proportional to ΔV_{be} . This voltage is measured by the ADC to give a temperature output in 8-bit, twos complement format. To further reduce the effects of noise, digital filtering is performed by averaging the results of 16 measurement cycles. A remote temperature measurement takes nominally 2.14 ms.

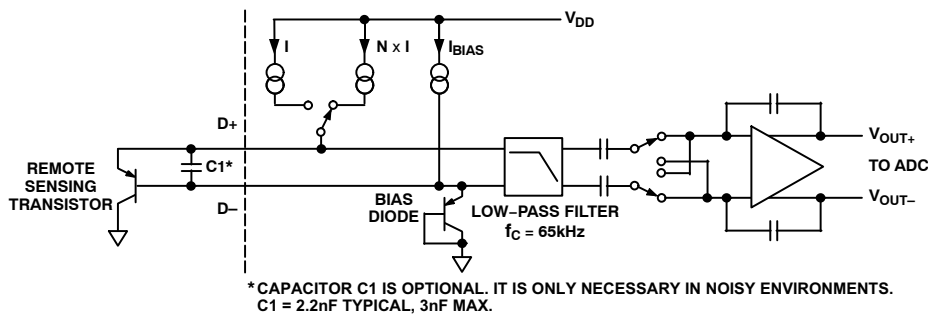

Figure 33. Signal Conditioning for Remote Diode Temperature Sensors

The results of external temperature measurements are stored in 8-bit, twos complement format, as illustrated in Table 8.

Table 8. TEMPERATURE DATA FORMAT

Temperature	Digital Output	Hex
-128°C	1000 0000	80
-125°C	1000 0011	83
-100°C	1001 1100	9C
-75°C	1011 0101	B5
-50°C	1100 1110	CE
-25°C	1110 0111	E7
-10°C	1111 0110	F6
0°C	0000 0000	00
10°C	0000 1010	0A
25°C	0001 1001	19
50°C	0011 0010	32
75°C	0100 1011	4B
100°C	0110 0100	64
125°C	0111 1101	7D
127°C	0111 1111	7F

Layout Considerations

Digital boards can be electrically noisy environments. Take these precautions to protect the analog inputs from noise, particularly when measuring the very small voltages from a remote diode sensor.

- Place the ADM1026 as close as possible to the remote sensing diode. Provided that the worst noise sources such as clock generators, data/address buses, and CRTs are avoided, this distance can be 4 to 8 inches.
- Route the D+ and D- tracks close together, in parallel, with grounded guard tracks on each side. Provide a ground plane under the tracks if possible.
- Use wide tracks to minimize inductance and reduce noise pickup. A 10 mil track minimum width and spacing is recommended.



Figure 34. Arrangement of Signal Tracks

- Try to minimize the number of copper/solder joints, which can cause thermocouple effects. Where copper/solder joints are used, make sure that they are in both the D+ and D- paths and are at the same temperature.
- Thermocouple effects should not be a major problem because 1°C corresponds to about 240 μV, and

thermocouple voltages are about 3 μV/°C of temperature difference. Unless there are two thermocouples with a big temperature differential between them, thermocouple voltages should be much less than 200 mV.

- Place a 0.1 μF bypass capacitor close to the ADM1026.
- If the distance to the remote sensor is more than eight inches, the use of twisted-pair cable is recommended. This works from about 6 to 12 feet.
- For very long distances (up to 100 feet), use shielded twisted pair such as Belden #8451 microphone cable. Connect the twisted pair to D+ and D- and the shield to GND close to the ADM1026. Leave the remote end of the shield unconnected to avoid ground loops.

Because the measurement technique uses switched current sources, excessive cable and/or filter capacitance can affect the measurement. When using long cables, the filter capacitor may be reduced or removed. Cable resistance can also introduce errors. A 1 Ω series resistance introduces about 0.5°C error.

Limit Values

Limit values for analog measurements are stored in the appropriate limit registers. In the case of voltage measurements, high and low limits can be stored so that an interrupt request is generated if the measured value goes above or below acceptable values. In the case of temperature, a hot temperature or high limit can be programmed, and a hot temperature hysteresis or low limit can be programmed, which is usually some degrees lower. This can be useful because it allows the system to be shut down when the hot limit is exceeded, and restarted automatically when it has cooled down to a safe temperature.

Analog Monitoring Cycle Time

The analog monitoring cycle begins when a 1 is written to the start bit (Bit 0), and a 0 to the INT_Clear bit (Bit 2) of the configuration register. INT_Enable (Bit 1) should be set to 1 to enable the INT output. The ADC measures each analog input in turn, starting with Remote Temperature Channel 1 and ending with local temperature. As each measurement is completed, the result is automatically stored in the appropriate value register. This round-robin monitoring cycle continues until it is disabled by writing a 0 to Bit 0 of the configuration register. Because the ADC is typically left to free-run in this way, the most recently measured value of any input can be read out at any time.

For applications where the monitoring cycle time is important, it can easily be calculated.

The total number of channels measured is:

- Five Dedicated Supply Voltage Inputs
- Ten General-purpose Analog Inputs
- 3.3 V MAIN
- 3.3 V STBY
- Local Temperature
- Two Remote Temperature

Pins 28 and 27 are measured both as analog inputs A_{IN8}/A_{IN9} and as remote temperature input $D2+/D2-$, irrespective of which configuration is selected for these pins.

If Pins 28 and 27 are configured as A_{IN8}/A_{IN9} , the measurements for these channels are stored in Registers 27h and 29h, and the invalid temperature measurement is discarded. On the other hand, if Pins 28 and 27 are configured as $D2+/D2-$, the temperature measurement is stored in Register 29h, and there is no valid result in Register 27h.

As mentioned previously, the ADC performs a conversion every 711 μ s on the analog and local temperature inputs and every 2.13 ms on the remote temperature inputs. Each input is measured 16 times and averaged to reduce noise.

The total monitoring cycle time for voltage and temperature inputs is therefore nominally:

$$(18 \times 16 \times 0.711) + (2 \times 16 \times 2.13) = 273 \text{ ms} \quad (\text{eq. 11})$$

The ADC uses the internal 22.5 kHz clock, which has a tolerance of $\pm 6\%$, so the worst-case monitoring cycle time is 290 ms. The fan speed measurement uses a completely separate monitoring loop, as described later.

Input Safety

Scaling of the analog inputs is performed on-chip, so external attenuators are typically not required. However, because the power supply voltages appear directly at the pins, it is advisable to add small external resistors (that is, 500 Ω) in series with the supply traces to the chip to prevent damaging the traces or power supplies should an accidental short such as a probe connect two power supplies together.

Because the resistors form part of the input attenuators, they affect the accuracy of the analog measurement if their value is too high. The worst such accident would be connecting -12 V to $+12 \text{ V}$ where there is a total of 24 V difference. With the series resistors, this would draw a maximum current of approximately 24 mA.

Analog Output

The ADM1026 has a single analog output from an unsigned 8-bit DAC that produces 0 V to 2.5 V (independent of the reference voltage setting). The input data for this DAC is contained in the DAC control register (Address 04h). The DAC control register defaults to FFh during a power-on reset, which produces maximum fan speed. The analog output may be amplified and buffered with external circuitry such as an op amp and a transistor to provide fan speed control. During automatic fan speed control, described later, the four MSBs of this register set the minimum fan speed.

Suitable fan drive circuits are shown in Figure 35 through Figure 39. When using any of these circuits, note the following:

- All of these circuits provide an output range from 0 V to almost +12 V, apart from Figure 35, which loses the base-emitter voltage drop of Q1 due to the emitter-follower configuration.

- To amplify the 2.5 V range of the analog output up to 12 V, the gain of these circuits needs to be about 4.8.
- Take care when choosing the op amp to ensure that its input common-mode range and output voltage swing are suitable.
- The op amp may be powered from the +12 V rail alone or from $\pm 12 \text{ V}$. If it is powered from +12 V, the input common-mode range should include ground to accommodate the minimum output voltage of the DAC, and the output voltage should swing below 0.6 V to ensure that the transistor can be turned fully off.
- If the op amp is powered from -12 V , precautions such as a clamp diode to ground may be needed to prevent the base-emitter junction of the output transistor being reverse-biased in the unlikely event that the output of the op amp should swing negative for any reason.
- In all these circuits, the output transistor must have an I_{CMAX} greater than the maximum fan current, and be capable of dissipating power due to the voltage dropped across it when the fan is not operating at full speed.
- If the fan motor produces a large back EMF when switched off, it may be necessary to add clamp diodes to protect the output transistors in the event that the output goes from full scale to zero very quickly.

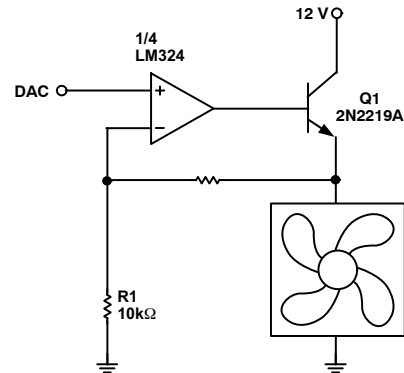

Figure 35. Fan Drive Circuit with Op Amp and Emitter-follower

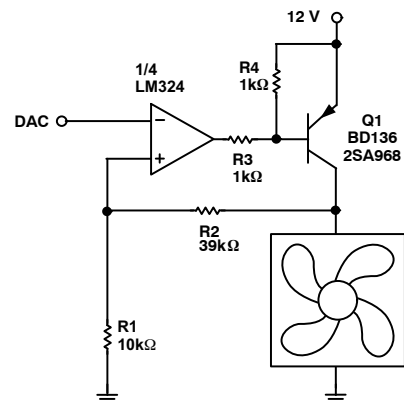

Figure 36. Fan Drive Circuit with Op Amp and PNP Transistor

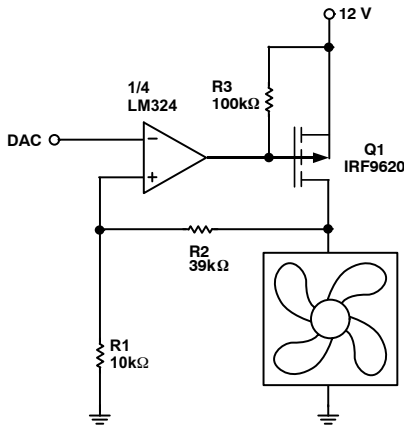

Figure 37. Fan Drive Circuit with Op Amp and P-channel MOSFET

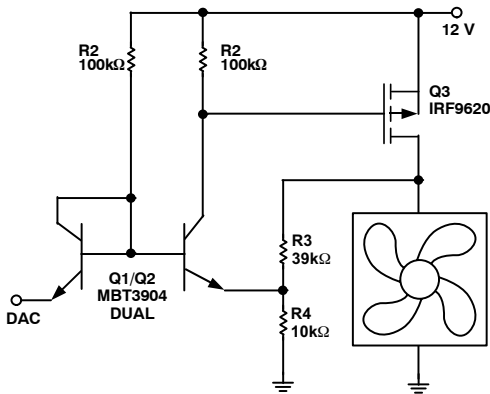

Figure 38. Discrete Fan Drive Circuit with P-channel MOSFET, Single Supply

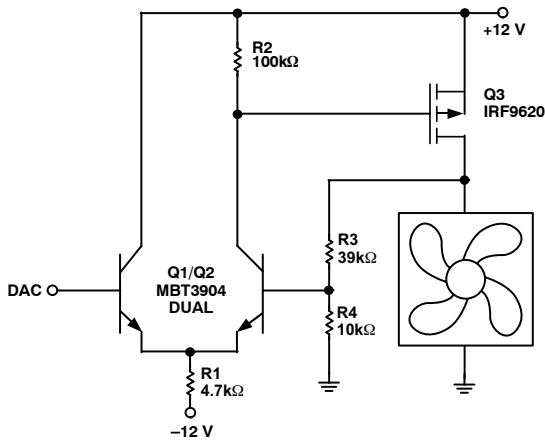

Figure 39. Discrete Fan Drive Circuit with P-channel MOSFET, Dual Supply

PWM Output

Fan speed may also be controlled using pulse width modulation (PWM). The PWM output (Pin 18) produces a pulsed output with a frequency of approximately 75 Hz and a duty cycle defined by the contents of the PWM control register (Address 05h). During automatic fan speed control,

described below, the four MSBs of this register set the minimum fan speed.

The open drain PWM output must be amplified and buffered to drive the fans. The PWM output is intended to be used with an NMOS driver, but may be inverted by setting Bit 1 of Test Register 1 (Address 14h) if using PMOS drivers. Figure 40 shows how a fan may be driven under PWM control using an N-channel MOSFET.

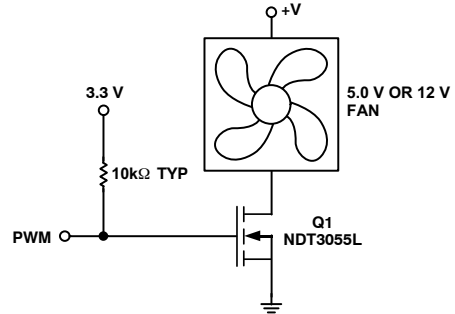

Figure 40. PWM Fan Drive Circuit Using an N-channel MOSFET

Automatic Fan Speed Control

The ADM1026 offers a simple method of controlling fan speed according to temperature without intervention from the host processor. Monitoring must be enabled by setting Bit 0 of Configuration Register 1 (Address 00h), to enable automatic fan speed control. Automatic fan speed control can be applied to the DAC output, the PWM output, or both, by setting Bit 5 and/or Bit 6 of Configuration Register 1.

The T_{MIN} registers (Addresses 10h to 12h) contain minimum temperature values for the three temperature channels (on-chip sensor and two remote diodes). This is the temperature at which a fan starts to operate when the temperature sensed by the controlling sensor exceeds T_{MIN}. T_{MIN} can be the same or different for all three channels. T_{MIN} is set by writing a twos complement temperature value to the T_{MIN} registers. If any sensor channel is not required for automatic fan speed control, T_{MIN} for that channel should be set to 127°C (01111111).

In automatic fan speed control mode, (as shown Figure 41 and Figure 42) the four MSBs of the DAC control register (Address 04h) and PWM control register (Address 05h) set the minimum values for the DAC and PWM outputs. Note that, if both DAC control and PWM control are enabled (Bits 5 and 6 of Configuration Register 1 = 1), the four MSBs of the DAC control register (Address 04h) define the minimum fan speed values for both the DAC and PWM outputs. The value in the PWM control register (Address 05h) has no effect.

$$\text{Minimum DAC Code } DAC_{MIN} = 16 \times D$$

$$\text{DAC Output Voltage} = 2.5 \times \frac{\text{Code}}{256} \quad (\text{eq. 12})$$

$$\text{Minimum PWM Duty Cycle } PWM_{MIN} = 6.67 \times D$$

where D is the decimal equivalent of Bits 7 to 4 of the register.

When the temperature measured by any of the sensors exceeds the corresponding T_{MIN} , the fan is spun up for 2 seconds with the fan drive set to maximum (full scale from the DAC or 100% PWM duty cycle). The fan speed is then set to the minimum as previously defined. As the temperature increases, the fan drive increases until the temperature reaches $T_{MIN} + 20^{\circ}C$.

The fan drive at any temperature up to $20^{\circ}C$ above T_{MIN} is given by:

$$PWM = PWM_{MIN} + (100 - PWM_{MIN}) \times \frac{T_{ACTUAL} - T_{MIN}}{20} \tag{eq. 13}$$

or

$$DAC = DAC_{MIN} + (240 - DAC_{MIN}) \times \frac{T_{ACTUAL} - T_{MIN}}{20} \tag{eq. 14}$$

For simplicity of the automatic fan speed algorithm, the DAC code increases linearly up to 240, not its full scale of 255. However, when the temperature exceeds $T_{MIN} + 20^{\circ}C$, the DAC output jumps to full scale. To ensure that the maximum cooling capacity is always available, the fan drive is always set by the sensor channel demanding the highest fan speed.

If the temperature falls, the fan does not turn off until the temperature measured by all three temperature sensors has fallen to their corresponding $T_{MIN} - 4^{\circ}C$. This prevents the fan from cycling on and off continuously when the temperature is close to T_{MIN} .

Whenever a fan starts or stops during automatic fan speed control, a one-off interrupt is generated at the \overline{INT} output. This is described in more detail in the section on the ADM1026 Interrupt Structure.

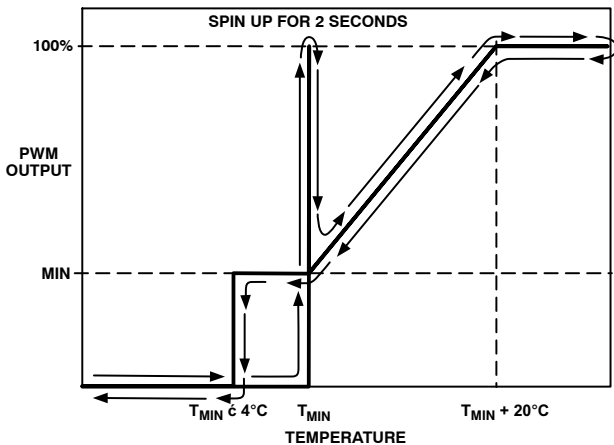

Figure 41. Automatic PWM Fan Control Transfer Function

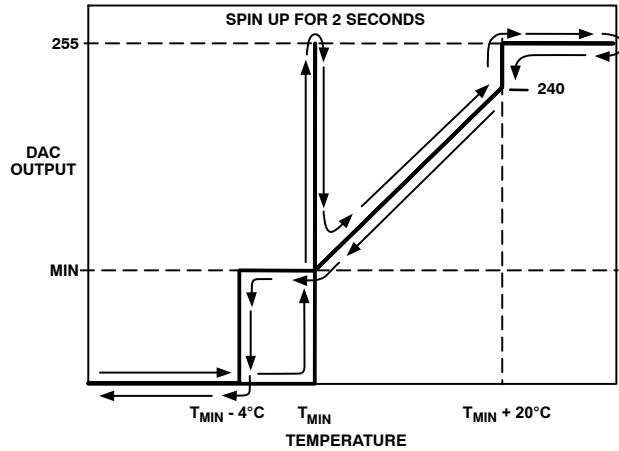

Figure 42. Automatic DAC Fan Control Transfer Function

Fan Inputs

Pins 3 to 6 and 9 to 12 may be configured as fan speed measuring inputs by clearing the corresponding bit(s) of Configuration Register 2 (Address 01h), or as general-purpose logic inputs/outputs by setting bits in this register. The power-on default value for this register is 00h, which means all the inputs are set for fan speed measurement.

Signal conditioning in the ADM1026 accommodates the slow rise and fall times typical of fan tachometer outputs. The fan tach inputs have internal 10 kΩ pullup resistors to 3.3 V STBY. In the event that these inputs are supplied from fan outputs that exceed the supply, either resistive attenuation of the fan signal or diode clamping must be included to keep inputs within an acceptable range. Figure 43 through Figure 47 show circuits for common fan tach outputs.

If the fan tach output is open-drain or has a resistive pullup to V_{CC} , then it can be connected directly to the fan input, as shown in Figure 44.

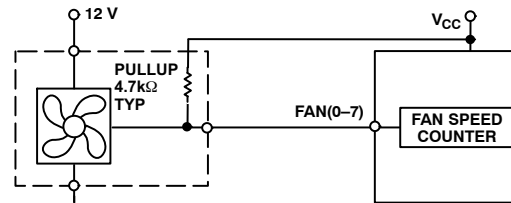

Figure 43. Fan with Tach Pullup to $+V_{CC}$

If the fan output has a resistive pullup to 12 V (or other voltage greater than 3.3 V STBY), the fan output can be clamped with a Zener diode, as shown in Figure 46. The Zener voltage should be chosen so that it is greater than V_{IH} but less than 3.3 V STBY, allowing for the voltage tolerance of the Zener.

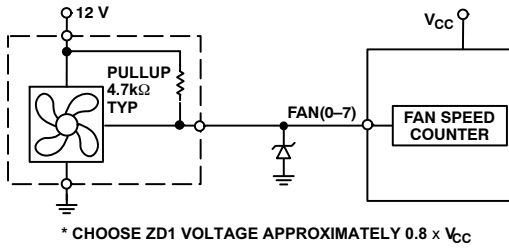

Figure 44. Fan with Tach Pullup to Voltage > V_{CC} (e.g. 12 V), Clamped with Zener Diode

If the fan has a strong pullup (less than 1 kΩ) to +12 V, or a totem pole output, a series resistor can be added to limit the Zener current, as shown in Figure 45. Alternatively, a resistive attenuator may be used, as shown in Figure 47.

R1 and R2 should be chosen such that:

$$2.0 \text{ V} < V_{\text{PULLUP}} \times \frac{R_2}{(R_{\text{PULLUP}} + R_1 + R_2)} < 3.3 \text{ V STBY} \quad (\text{eq. 15})$$

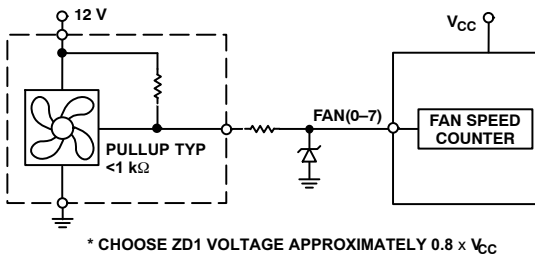

Figure 45. Fan with Strong Tach Pullup to >V_{CC} or Totem Pole Output, Attenuated with R1/R2

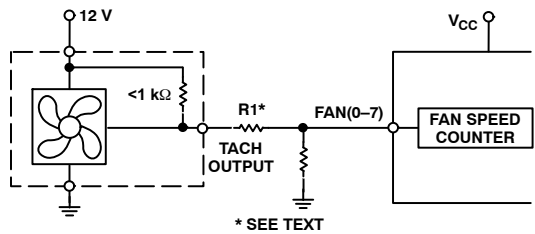

Figure 46. Fan with Strong Tach Pullup to > V_{CC} or Totem Pole Output, Clamped with Zener and Resistor

Fan Speed Measurement

The fan counter does not count the fan tach output pulses directly because the fan speed may be less than 1000 RPM and it would take several seconds to accumulate a reasonably large and accurate count. Instead, the period of the fan revolution is measured by gating an on-chip 22.5 kHz oscillator into the input of an 8-bit counter for two periods of the fan tach output, as shown in Figure 47, so the accumulated count is actually proportional to the fan tach period and inversely proportional to the fan speed.

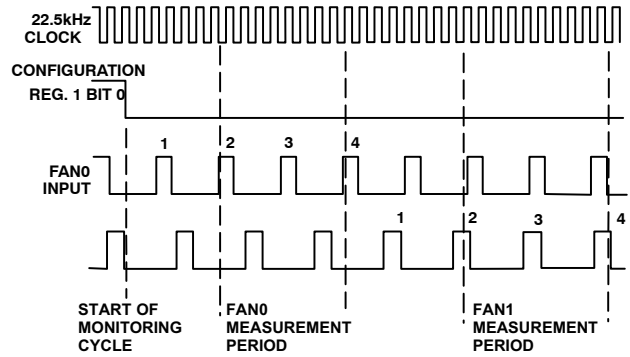

Figure 47. Fan Speed Measurement

The monitoring cycle begins when a 1 is written to the monitor bit (Bit 0 of Configuration Register 1). The INT_Enable (Bit 1) should be set to 1 to enable the INT output.

The fan speed counter starts counting as soon as the fan channel has been switched to. If the fan tach count reaches 0xFF, the fan has failed or is not connected. If a fan is connected and running, the counter is reset on the second tach rising edge, and oscillator pulses are actually counted from the second rising tach edge to the fourth rising edge. The measurement then switches to the next fan channel. Here again, the counter begins counting and is reset on the second tach rising edge, and oscillator pulses are counted from the second rising edge to the fourth rising edge. This is repeated for the other six fan channels.

Note that fan speed measurement does not occur until 1.8 seconds after the monitor bit has been set. This is to allow the fans adequate time to spin up. Otherwise, the ADM1026 could generate false fan failure interrupts. During the 1.8 second fan spin-up time, all fan tach registers read 0x00.

To accommodate fans of different speed and/or different numbers of output pulses per revolution, a prescaler (divisor) of 1, 2, 4, or 8 may be added before the counter. Divisor values for Fans 0 to 3 are contained in the Fan 0–3 divisor register (Address 02h) and those for Fans 4 to 7 in the Fan 4–7 divisor register (Address 03h). The default value is 2, which gives a count of 153 for a fan running at 4400 RPM producing two output pulses per revolution. The count is calculated by the equation:

$$\text{Count} = \frac{22.5 \times 10^3 \times 60}{\text{RPM} \times \text{Divisor}} \quad (\text{eq. 16})$$

For constant-speed fans, fan failure is typically considered to have occurred when the speed drops below 70% of nominal, corresponding to a count of 219. Full scale (255) is reached if the fan speed fell to 60% of its nominal value. For temperature-controlled, variable-speed fans, the situation is different.

Table 9 shows the relationship between fan speed and time per revolution at 60%, 70%, and 100% of nominal RPM for fan speeds of 1100, 2200, 4400, and 8800 RPM, and the divisor that would be used for each of these fans, based on two tach pulses per revolution.

Limit Values

Fans generally do not over-speed if run from the correct voltage, so the failure condition of interest is under speed due to electrical or mechanical failure. For this reason, only low speed limits are programmed into the limit registers for the fans. It should be noted that because fan period rather than speed is being measured, a fan failure interrupt occurs when the measurement exceeds the limit value.

Fan Monitoring Cycle Time

The fan speeds are measured in sequence from 0 to 7. The monitoring cycle time depends on the fan speed, the number of tach output pulses per revolution, and the number of fans being monitored.

If a fan is stopped or running so slowly that the fan speed counter reaches 255 before the second tach pulse after

initialization or before the fourth tach pulse during measurement, the measurement is terminated. This also occurs if an input is configured as GPIO instead of fan. Any channels connected in this manner time out after 255 clock pulses.

The worst-case measurement time for a fan-configured channel occurs when the counter reaches 254 from start to the second tach pulse and reaches 255 after the second tach pulse. Taking into account the tolerance of the oscillator frequency, the worst-case measurement time is:

$$509 \times D \times 0.05 \text{ ms} \quad (\text{eq. 17})$$

where:

509 is the total number of clock pulses.

D is the divisor: 1, 2, 4, or 8.

0.05 ms is the worst-case oscillator period in ms.

The worst-case fan monitoring cycle time is the sum of the worst-case measurement time for each fan.

Although the fan monitoring cycle and the analog input monitoring cycle are started together, they are not synchronized in any other way.

Table 9. FAN SPEEDS AND DIVISORS

Divisor RPM	Nominal Rev	Time Per				
		RPM (ms)	70% RPM	Rev 70% (ms)	60% RPM	Rev 60% (ms)
÷ 1	8800	6.82	6160	9.74	5280	11.36
÷ 2	4400	13.64	3080	19.48	2640	22.73
÷ 4	2200	27.27	1540	38.96	1320	45.45
÷ 8	1100	54.54	770	77.92	660	90.9

Chassis Intrusion Input

The chassis intrusion input is an active high input intended for detection and signaling of unauthorized tampering with the system. When this input goes high, the event is latched in Bit 6 of Status Register 4, and an interrupt is generated. The bit remains set until cleared by writing a 1 to CI clear, Bit 1 of Configuration Register 3 (05h), as long as battery voltage is connected to the V_{BAT} input. The CI clear bit itself is cleared by writing a 0 to it.

The CI input detects chassis intrusion events even when the ADM1026 is powered off (provided battery voltage is applied to V_{BAT}) but does not immediately generate an interrupt. Once a chassis intrusion event is detected and latched, an interrupt is generated when the system is powered on.

The actual detection of chassis intrusion is performed by an external circuit that detects, for example, when the cover has been removed. A wide variety of techniques may be used for the detection, for example:

- A Microswitch that Opens or Closes when the Cover is Removed
- A Reed Switch Operated by Magnet Fixed to the Cover
- A Hall-effect Switch Operated by Magnet Fixed to the Cover
- A Phototransistor that Detects Light when the Cover is Removed

The chassis intrusion input can also be used for other types of alarm input. Figure 48 shows a temperature alarm circuit using an AD22105 temperature switch sensor. This produces a low-going output when the preset temperature is exceeded, so the output is inverted by Q1 to make it compatible with the CI input. Q1 can be almost any small-signal NPN transistor, or a TTL or CMOS inverter gate may be used if one is available.

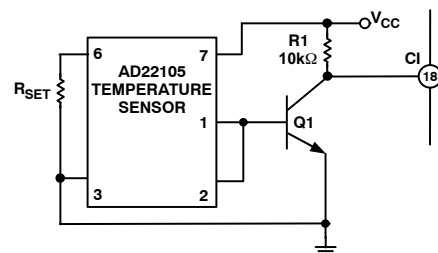

Figure 48. Using the CI Input with a Temperature Sensor

General-Purpose I/O Pins (Open Drain)

The ADM1026 has eight pins that are dedicated to general-purpose logic input/output (Pins 1, 2, and 43 to 48), eight pins that can be configured as general-purpose logic pins or fan speed inputs (Pins 3 to 6, and 9 to 12), and one pin that can be configured as GPIO16 or the bidirectional THERM pin (Pin 42). The GPIO/FAN pins are configured as general-purpose logic pins by setting Bits 0 to 7 of

Configuration Register 2 (Address 01h). Pin 42 is configured as GPIO16 by setting Bit 0 of Configuration Register 3, or as the $\overline{\text{THERM}}$ function by clearing this bit.

Each GPIO pin has four data bits associated with it, two bits in one of the GPIO configuration registers (Addresses 08h to 0Bh), one in the GPIO status registers (Addresses 24h and 25h), and one in the GPIO mask registers (Addresses 1Ch and 1Dh)

Setting a direction bit = 1 in one of the GPIO configuration registers makes the corresponding GPIO pin an output. Clearing the direction bit to 0 makes it an input.

Setting a polarity bit = 1 in one of the GPIO configuration registers makes the corresponding GPIO pin active high. Clearing the polarity bit to 0 makes it active low.

When a GPIO pin is configured as an input, the corresponding bit in one of the GPIO status registers is read-only, and is set when the input is asserted (“asserted” may be high or low depending on the setting of the polarity bit).

When a GPIO pin is configured as an output, the corresponding bit in one of the GPIO status registers becomes read/write. Setting this bit then asserts the GPIO output. (Here again, “asserted” may be high or low depending on the setting of the polarity bit.)

The effect of a GPIO status register bit on the $\overline{\text{INT}}$ output can be masked out by setting the corresponding bit in one of the GPIO mask registers. When the pin is configured as an output, this bit is automatically masked to prevent the data written to the status bit from causing an interrupt, with the exception of GPIO16, which must be masked manually by setting Bit 7 of Mask Register 4 (Reg 1Bh).

When configured as inputs, the GPIO pins may be connected to external interrupt sources such as temperature sensors with digital output. Another application of the GPIO pins would be to monitor a processor’s voltage ID code (VID code).

ADM1026 Interrupt Structure

The Interrupt Structure of the ADM1026 is shown in Figure 52. Interrupts can come from a number of sources, which are combined to form a common $\overline{\text{INT}}$ output. When $\overline{\text{INT}}$ is asserted, this output pulls low. The $\overline{\text{INT}}$ pin has an internal, 100 k Ω pullup resistor.

Analog/Temperature Inputs

As each analog measurement value is obtained and stored in the appropriate value register, the value and the limits from the corresponding limit registers are fed to the high and low limit comparators. The device performs greater than comparisons to the high limits. An out-of-limit is also generated if a result is less than or equal to a low limit. The result of each comparison (1 = out of limit, 0 = in limit) is routed to the corresponding bit input of Interrupt Status Register 1, 2, or 4 via a data de-multiplexer, and used to set that bit high or low as appropriate. Status bits are self-clearing. If a bit in a status register is set due to an out-of-limit measurement, it continues to cause $\overline{\text{INT}}$ to be asserted as long as it remains set, as described later. However, if a subsequent measurement is in limit, it is reset and does not cause $\overline{\text{INT}}$ to be reasserted. Status bits are unaffected by clearing the interrupt.

Interrupt Mask Registers 1, 2, and 4 have bits corresponding to each of the interrupt status register bits. Setting an interrupt mask bit high conceals an asserted status bit from display on Interrupt Pin 17. Setting an interrupt mask bit low allows the corresponding status bit to be asserted and displayed on Pin 17. After mask gating, the status bits are all OR’ed together to produce the analog and fan interrupt that is used to set a latch. The output of this latch is OR’ed with other interrupt sources to produce the $\overline{\text{INT}}$ output. This pulls low if any unmasked status bit goes high, that is, when any measured value goes out of limit.

When an $\overline{\text{INT}}$ output caused by an out-of-limit analog/temperature measurement is cleared by one of the methods described later, the latch is reset. It is not set again, and $\overline{\text{INT}}$ is not reasserted until after two local temperature measurements have been taken, even if the status bit remains set or a new analog/temperature event occurs, as shown in Figure 49. This delay corresponds to almost two monitoring cycles, and is about 530 ms. However, interrupts from other sources such as a fan or GPIO can still occur. This is illustrated in Figure 50.

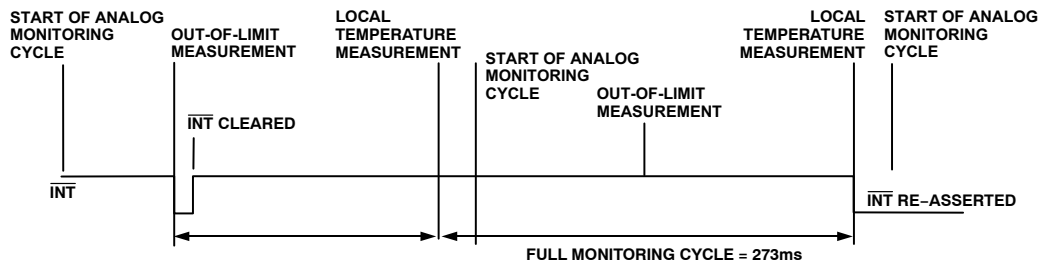

Figure 49. Delay After Clearing $\overline{\text{INT}}$ Before Reassertion

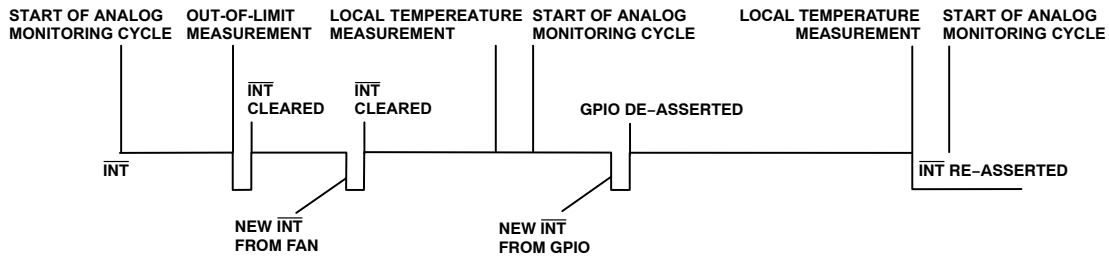

Figure 50. Other Interrupt Sources Can Reassert $\overline{\text{INT}}$ Immediately

Status Register 4 also stores inputs from two other interrupt sources that operate in a different way from the other status bits. If automatic fan speed control (AFC) is enabled, Bit 4 of Status Register 4 is set whenever a fan starts or stops. This bit causes a one-off $\overline{\text{INT}}$ output as shown in Figure 51. It is cleared during the next monitoring cycle and if $\overline{\text{INT}}$ has been cleared, it does not cause $\overline{\text{INT}}$ to be reasserted.

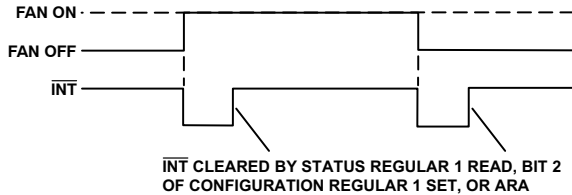

Figure 51. Assertion of $\overline{\text{INT}}$ Due to AFC Event

In a similar way, a change of state at the $\overline{\text{THERM}}$ output (described in more detail later), sets Bit 3 of Status Register 4 and causes a one-off $\overline{\text{INT}}$ output. A change of state at the $\overline{\text{THERM}}$ output also causes Bit 0 of Status Register 1, Bit 1 of Status Register 1, or Bit 0 of Status Register 4 to be set, depending on which temperature channel caused the $\overline{\text{THERM}}$ event. This bit is reset during the next monitoring cycle, provided the temperature channel is within the normal high and low limits.

Fan Inputs

Fan inputs generate interrupts in a similar way to analog/temperature inputs, but as the analog/temperature inputs and fan inputs have different monitoring cycles, they have separate interrupt circuits. As the speed of each fan is measured, the output of the fan speed counter is stored in a value register. The result is compared to the fan speed limit and is used to set or clear a bit in Status Register 3. In this case, the fan is monitored only for underspeed (fan counter > fan speed limit). Mask Register 3 is used to mask fan interrupts. After mask gating, the fan status bits are OR'ed together and used to set a latch, whose output is OR'ed with other interrupt sources to produce the $\overline{\text{INT}}$ output.

Like the analog/temp interrupt, an $\overline{\text{INT}}$ output caused by an out-of-limit fan speed measurement, once cleared, is not reasserted until the end of the next monitoring cycle, although other interrupt sources may cause $\overline{\text{INT}}$ to be asserted.

GPIO and CI Pins. When GPIO pins are configured as inputs, asserting a GPIO input (high or low, depending on polarity) sets the corresponding GPIO status bit in Status

Registers 5 and 6, or Bit 7 of Status Register 4 (GPIO16). A chassis intrusion event sets Bit 6 of Status Register 4.

The GPIO and CI status bits, after mask gating, are OR'ed together and OR'ed with other interrupt sources to produce the $\overline{\text{INT}}$ output. GPIO and CI interrupts are not latched and cannot be cleared by normal interrupt clearing. They can only be cleared by masking the status bits or by removing the source of the interrupt.

Enabling and Clearing Interrupts

The $\overline{\text{INT}}$ output is enabled when Bit 1 of Configuration Register 1 (INT_Enable) is high, and Bit 2 (INT_Clear) is low. $\overline{\text{INT}}$ may be cleared if:

- Status Register 1 is read. Ideally, if polling the status registers trying to identify interrupt sources, Status Register 1 should be polled last, because a read of Status Register 1 clears all the other interrupt status registers.
- The ADM1026 receives the alert response address (ARA) (0001 100) over the SMBus.
- Bit 2 of Configuration Register 1 is set.

Bidirectional $\overline{\text{THERM}}$ Pin

The ADM1026 has a second interrupt pin (GPIO16/ $\overline{\text{THERM}}$ Pin 42) that responds only to critical thermal events. The $\overline{\text{THERM}}$ pin goes low whenever a $\overline{\text{THERM}}$ limit is exceeded. This function is useful for CPU throttling or system shutdown. In addition, whenever $\overline{\text{THERM}}$ is activated, the PWM and DAC outputs go full scale to provide fail-safe system cooling. This output is enabled by setting Bit 4 of Configuration Register 1 (Register 00h). Whenever a $\overline{\text{THERM}}$ limit is exceeded, Bit 3 of Status Register 4 (Reg 23h) is set, even if the $\overline{\text{THERM}}$ function is disabled (Bit 4 of Configuration Register 1 = 0). In this case, the $\overline{\text{THERM}}$ status bit is set, but the PWM and DAC outputs are not forced to full scale.

Three thermal limit registers are provided for the three temperature sensors at Addresses 0Dh to 0Fh. These registers are dedicated to the $\overline{\text{THERM}}$ function and none of the other limit registers have any effect on the $\overline{\text{THERM}}$ output.

If any of the temperature measurements exceed the corresponding limit, $\overline{\text{THERM}}$ is asserted (low) and the DAC and PWM outputs go to maximum to drive any cooling fans to full speed.

To avoid cooling fans cycling on and off continually when the temperature is close to the limit, a fixed hysteresis of 5°C

ADM1026

is provided. $\overline{\text{THERM}}$ is only deasserted when the measured temperature of all three sensors is 5°C below the limit.

Whenever the $\overline{\text{THERM}}$ output changes, $\overline{\text{INT}}$ is asserted, as shown in Figure 53. However, this is edge-triggered, so

if $\overline{\text{INT}}$ is subsequently cleared by one of the methods previously described, it is not reasserted, even if $\overline{\text{THERM}}$ remains asserted. $\overline{\text{THERM}}$ causes $\overline{\text{INT}}$ to be reasserted only when it changes state.

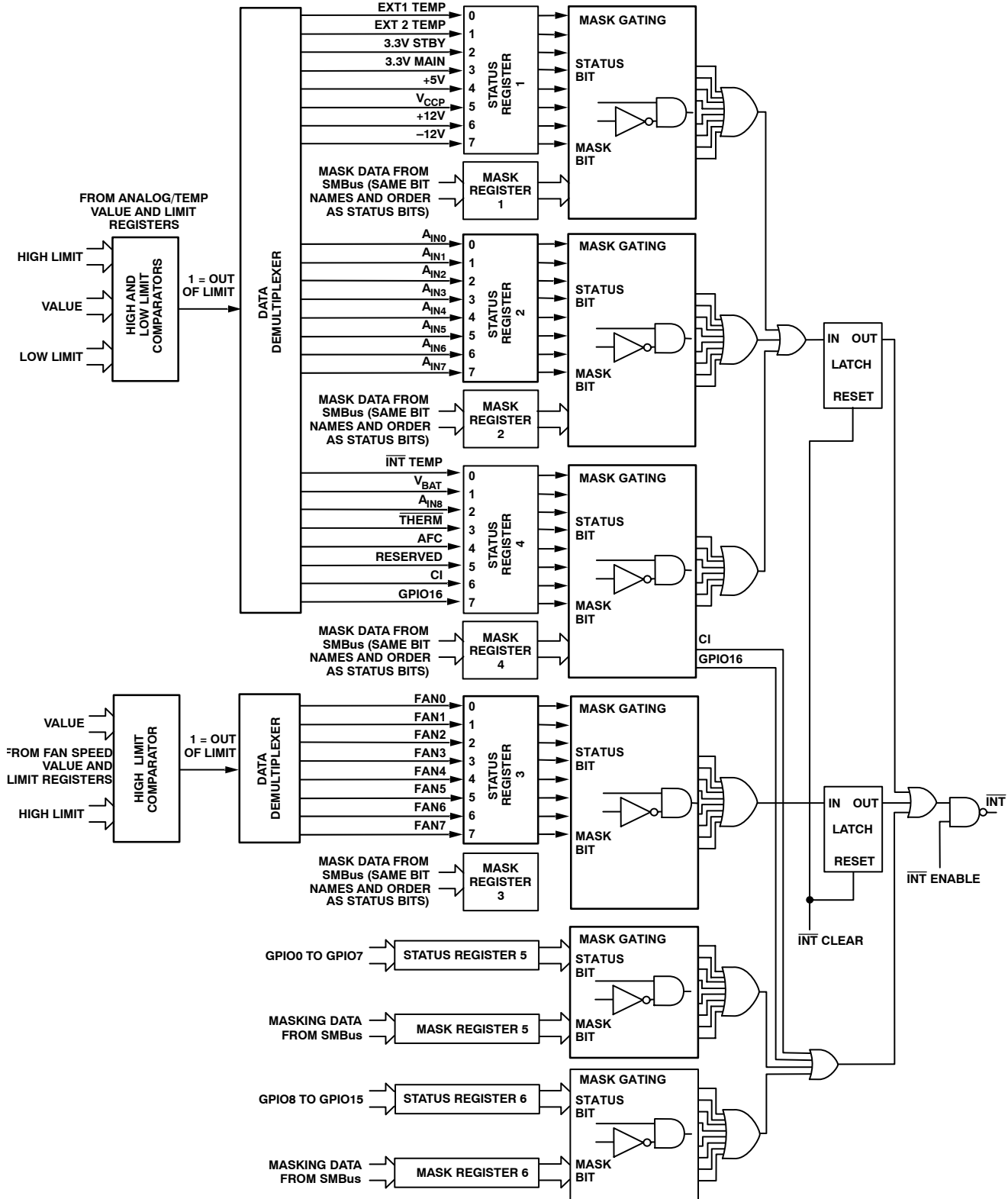

Figure 52. Interrupt Structure

Note that the $\overline{\text{THERM}}$ pin is bidirectional, so $\overline{\text{THERM}}$ may be pulled low externally as an input. This causes the PWM and DAC outputs to go to full scale until $\overline{\text{THERM}}$ is returned high again. To disable $\overline{\text{THERM}}$ as an input, set Bit 0 of Configuration Register 3 (Reg. 07h). This configures Pin 42 as GPIO16 and prevents a low on Pin 42 from driving the fans at full speed.

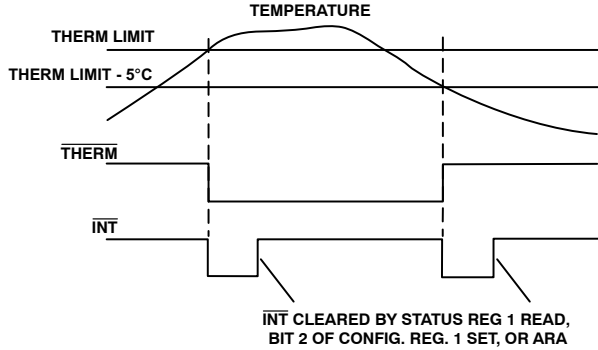

Figure 53. Assertion of $\overline{\text{INT}}$ Due to $\overline{\text{THERM}}$ Event

Reset Input and Outputs

The ADM1026 has two active low, power-on reset outputs, $\overline{\text{RESETMAIN}}$ and $\overline{\text{RESETSTBY}}$. These operate as follows.

$\overline{\text{RESETSTBY}}$ monitors 3.3 V STBY. At powerup, $\overline{\text{RESETSTBY}}$ is asserted (pulled low) until 180 ms after 3.3 V STBY rises above the reset threshold.

$\overline{\text{RESETMAIN}}$ monitors 3.3 V MAIN. This means that at powerup, $\overline{\text{RESETMAIN}}$ is asserted (pulled low) until 180 ms after 3.3 V MAIN rises above the reset threshold.

If 3.3 V MAIN rises with or before DV_{CC} , $\overline{\text{RESETMAIN}}$ remains asserted until 180 ms after $\overline{\text{RESETSTBY}}$ is negated. $\overline{\text{RESETMAIN}}$ can also function as a RESET input. Pulling this pin low resets the registers, which are initialized to their default values by a software reset. (See the Software Reset Function section for register details).

Note that the 3.3 V STBY pin supplies power to the ADM1026. In applications that do not require monitoring of a 3.3 V STBY and 3.3 V MAIN supply, these two pins should be connected together (3.3 V MAIN should not be left floating).

To ensure that the 3.3 V STBY pin does not become back driven, the 3.3 V STBY supply should power on before all other voltages in the system.

See Table 5 for more information about pin configuration.

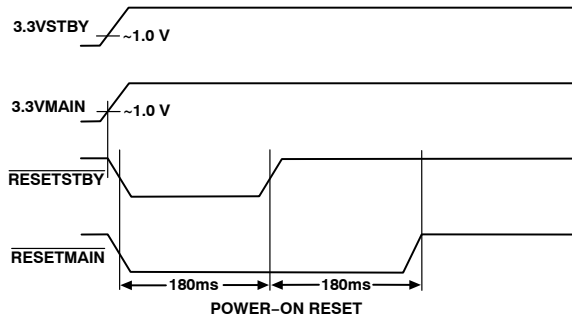

Figure 54. Operation of Offset Outputs

NAND Tree Tests

A NAND tree is provided in the ADM1026 for automated test equipment (ATE) board-level connectivity testing. This allows the functionality of all digital inputs to be tested in a simple manner and any pins that are nonfunctional or shorted together to be identified. The structure of the NAND tree is shown in Figure 55. The device is placed into NAND tree test mode by powering up with Pin 25 held high. This pin is sampled automatically after powerup, and if it is connected high, then the NAND test mode is invoked.

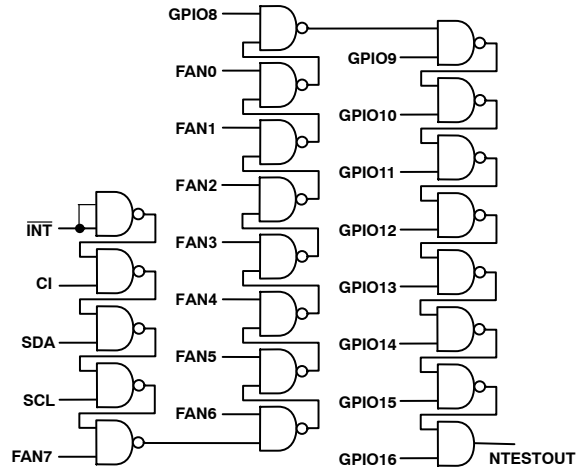

Figure 55. NAND Tree

The NAND tree test may be carried out in one of two ways.

1. Start with all inputs low and take them high in turn, starting with the input nearest to NTEST_OUT (GPIO16/ $\overline{\text{THERM}}$) and working back up the tree to the input furthest from NTESTOUT ($\overline{\text{INT}}$). This should give the characteristic output pattern shown in Figure 56, with NTESTOUT toggling each time an input is taken high.
2. Start with all inputs high and take them low in turn, starting with the input furthest from NTEST_OUT ($\overline{\text{INT}}$) and working down the tree to the input nearest to NTEST_OUT (GPIO16/ $\overline{\text{THERM}}$). This should give a similar output pattern to Figure 57.

Notes:

- For a NAND tree test to work, all outputs ($\overline{\text{INT}}$, RSTMAIN, RSTSTBY, and PWM) must remain high during the test.
- When generating test waveforms, allow for a typical propagation delay of 500 ns through the NAND tree.
- If any of the inputs shown in Figure 55 are unused, they should not be connected direct to ground, but via a resistor such as 10 k Ω . This allows the automatic test equipment (ATE) to drive every input high so that the NAND tree test can be properly carried out.

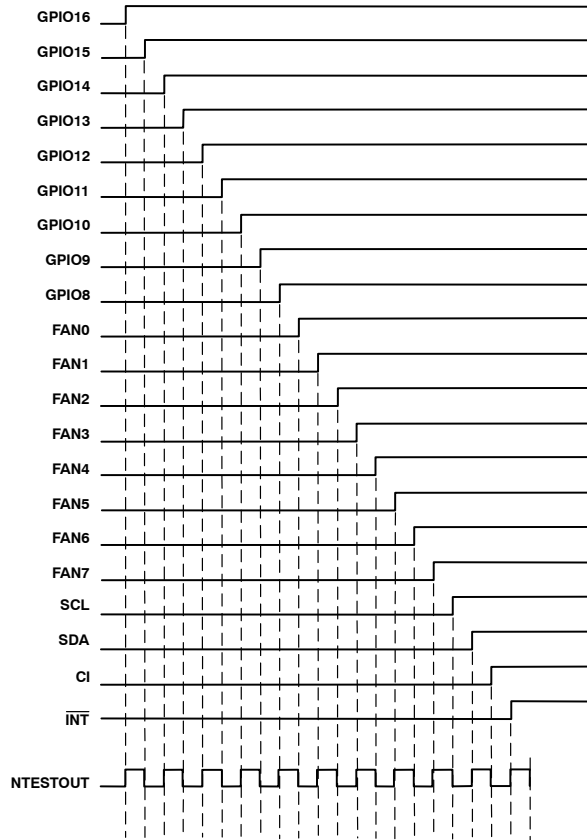

Figure 56. NAND Tree Test Taking Inputs High in Turn

In the event of an input being nonfunctional (stuck high or low) or two inputs shorted together, the output pattern is different. Some examples are given in Figure 58 through Figure 60.

Figure 58 shows the effect of one input being stuck low. The output pattern is normal until the stuck input is reached. Because that input is permanently low, neither it nor any inputs further up the tree can have any effect on the output.

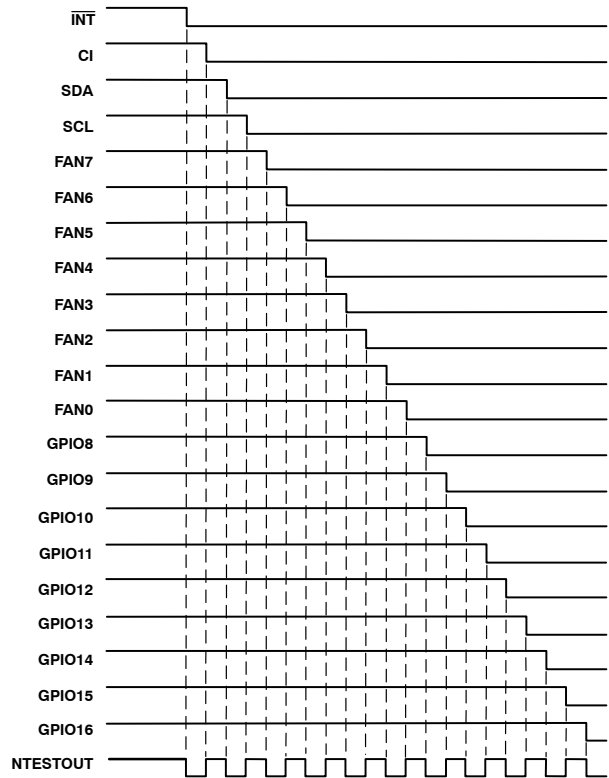

Figure 57. NAND Tree Test Taking Inputs Low in Turn

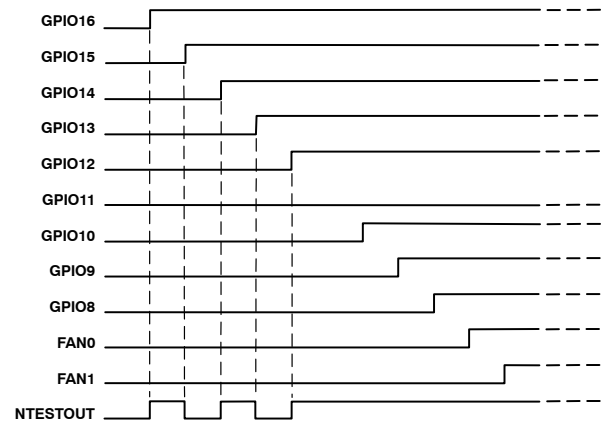

Figure 58. NAND Tree Test with GPIO11 Stuck Low

Figure 59 shows the effect of one input being stuck high. Taking GPIO12 high should take the output high. However, the next input up the tree, GPIO11, is already high, so the output immediately goes low again, causing a missing pulse in the output pattern.

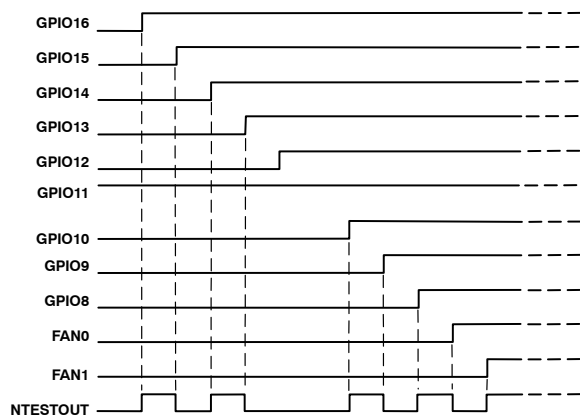

Figure 59. NAND Tree Test with One Input Stuck High

A similar effect occurs if two adjacent inputs are shorted together. The example in Figure 60 assumes that the current sink capability of the circuit driving the inputs is considerably higher than the source capability, so the inputs are low if either is low, but high only if both are high.

When GPIO12 goes high the output should go high. But because GPIO12 and GPIO11 are shorted, they both go high together, causing a missing pulse in the output pattern.

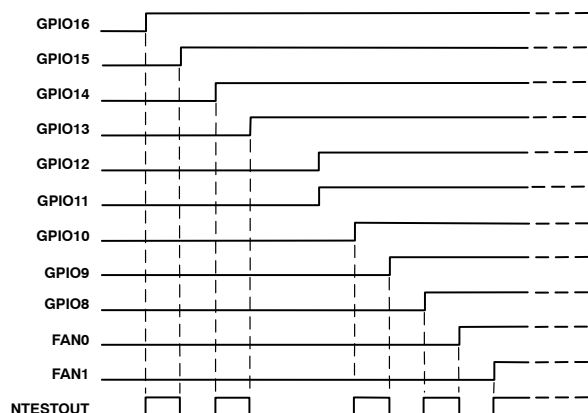

Figure 60. NAND Tree Test with Two Inputs Shorted

Using the ADM1026

When power is first applied, the ADM1026 performs a power-on reset on all its registers (not EEPROM), which sets them to default conditions as shown in Table 13. In particular, note that all GPIO pins are configured as inputs to avoid possible conflicts with circuits trying to drive these pins.

The ADM1026 can also be initialized at any time by writing a 1 to Bit 7 of Configuration Register 1, which sets some registers to their default power-on conditions. This bit should be cleared by writing a 0 to it.

After power-on, the ADM1026 must be configured to the user’s specific requirements. This consists of:

- Writing values to the limit registers.
- Configuring Pins 3 to 6, and 9 to 12 as fan inputs or GPIO, using Configuration Register 2 (Address 01h).

- Setting the fan divisors using the fan divisor registers (Addresses 02h and 03h).
- Configuring the GPIO pins for input/output polarity, using GPIO Configuration Registers 1 to 4 (Addresses 08h to 0Bh) and Bits 6 and 7 of Configuration Register 3.
- Setting mask bits in Mask Registers 1 to 6 (Addresses 18h to 1Dh) for any inputs that are to be masked out.
- Setting up Configuration Registers 1 and 3, as described in Table 10 and Table 11.

Table 10. CONFIGURATION REGISTER 1

Bit	Description
0	Controls the monitoring loop of the ADM1026. Setting Bit 0 low stops the monitoring loop and puts the ADM1026 into low power mode and reduces power consumption. Serial bus communication is still possible with any register in the ADM1026 while in low power mode. Setting bit 0 high starts the monitoring loop.
1	Enables or disables the $\overline{\text{INT}}$ interrupt output. Setting Bit 1 high enables the $\overline{\text{INT}}$ output, setting Bit 1 low disables the output.
2	Used to clear the $\overline{\text{INT}}$ interrupt output when set high. GPIO pins and interrupt status register contents are not affected.
3	Configures Pins 27 and 28 as the second external temperature channel when 0, and as $A_{\text{IN}8}$ and $A_{\text{IN}9}$ when set to 1.
4	Enables the $\overline{\text{THERM}}$ output when set to 1.
5	Enables automatic fan speed control on the DAC output when set to 1.
6	Enables automatic fan speed control on the PWM output when set to 1.
7	Performs a soft reset when set to 1.

Table 11. CONFIGURATION REGISTER 3

Bit	Description
0	Configures Pin 42 as GPIO when set to 1 or as $\overline{\text{THERM}}$ when cleared to 0.
1	Clears the CI latch when set to 1. Thereafter, a 0 must be written to allow subsequent CI detection.
2	Selects V_{REF} as 2.5 V when set to 1 or as 1.82 V when cleared to 0.
3–5	Unused.
6, 7	Set up GPIO16 for direction and polarity.

Starting Conversion

The monitoring function (analog inputs, temperature, and fan speeds) in the ADM1026 is started by writing to Configuration Register 1 and setting Start (Bit 0) high. The $\overline{\text{INT}}_{\text{Enable}}$ (Bit 1) should be set to 1, and $\overline{\text{INT}}_{\text{Clear}}$ (Bit 2) set to 0 to enable interrupts. The $\overline{\text{THERM}}$ enable bit (Bit 4) should be set to 1 to enable temperature interrupts at the $\overline{\text{THERM}}$ pin. Apart from initially starting together, the analog measurements and fan speed measurements proceed independently, and are not synchronized in any way.

ADM1026

Reduced Power Mode

The ADM1026 can be placed in a low power mode by setting Bit 0 of the configuration register to 0. This disables the internal ADC.

Software Reset Function

As previously mentioned, the ADM1026 can be reset in software by setting Bit 7 of Configuration Register 1 (Reg. 00h) to 1. Configuration Register 1, 00h, should then be manually cleared. Note that the software reset differs from a power-on reset in that only some of the ADM1026 registers are reinitialized to their power-on default values. The registers that are initialized to their default values by the software reset are

- Configuration Registers (Registers 01h to 0Bh)
- Mask Registers 1 to 6, internal temperature offset, and Status Registers 4, 5, and 6 (Registers 18h to 25h)
- All value registers (Registers 1Fh, 20h to 3Fh)
- External 1 and External 2 Offset Registers (6Eh, 6Fh)

Note that the limit registers (0Dh to 12h, 40h to 6Dh) are not reset by the software reset function. This can be useful if one needs to reset the part but does not want to reprogram all parameters again. Note that a power-on reset initializes all registers on the ADM1026, including the limit registers.

Application Schematic

Figure 61 shows how the ADM1026 could be used in an application that requires system management of a PC or server. Several GPIOs are used to read the VID codes of the CPU. Up to two CPU temperature measurements can be read back. All power supply voltages are monitored in the system. Up to eight fan speeds can be measured, irrespective of whether they are controlled by the ADM1026 or hardwired to a system supply. The V_{REF} output includes the recommended filtering circuitry.

ADM1026

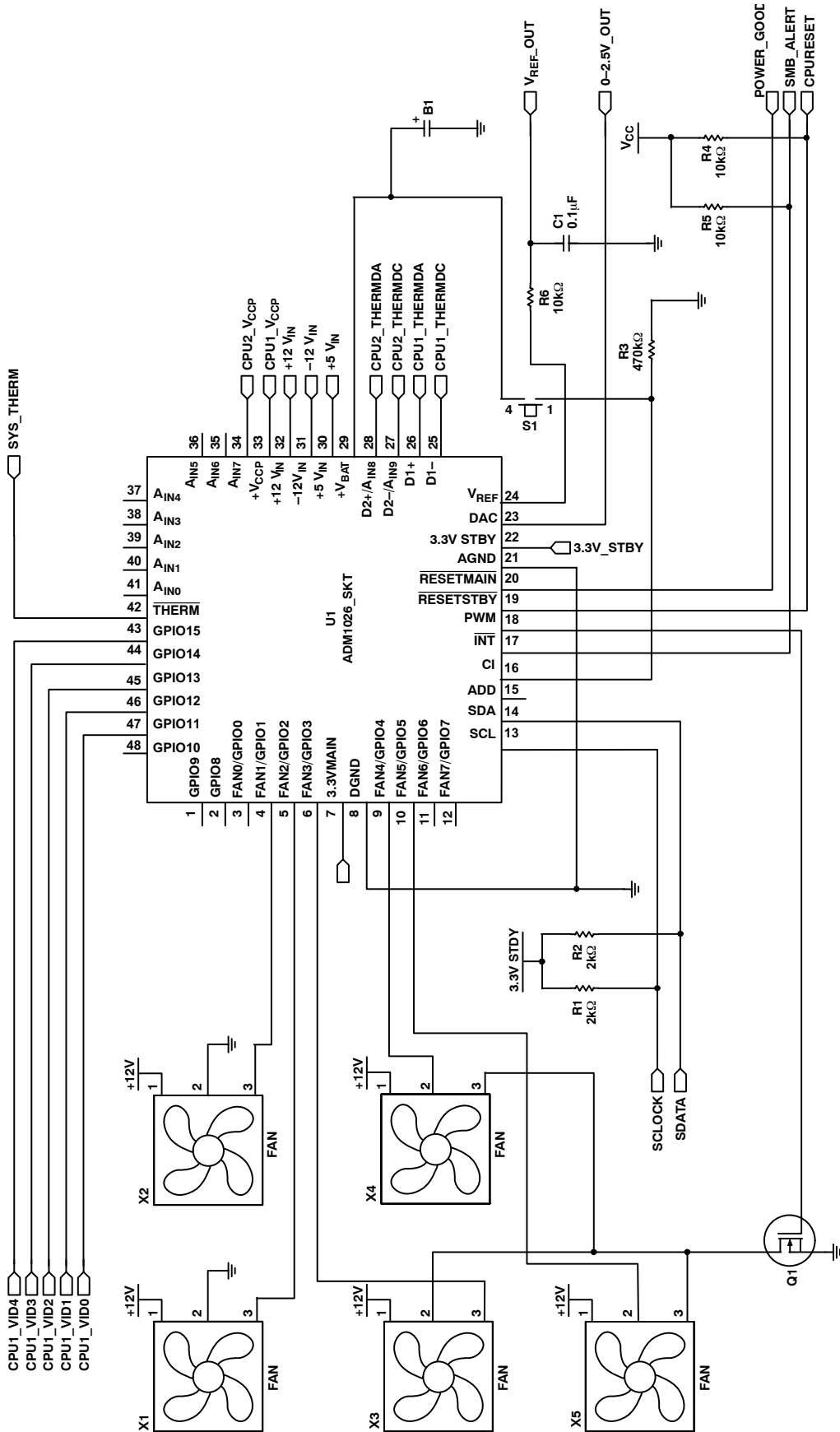

Figure 61. ADM1026 Schematic

ADM1026

Registers

Table 12. ADDRESS POINTER REGISTER

Bit	Name	R/W	Description
7–0	Address Pointer	W	Address of ADM1026 registers. See the following tables for details.

Table 13. LIST OF REGISTERS

Hex Address	Name	Power-on Value	Description
00	Configuration 1	00h	Configures various operating parameters .
01	Configuration 2	00h	Configures Pins 3–6 and 9–12 as fan inputs or GPIO.
02	Fan 0–3 Divisor	55h	Sets oscillator frequency for Fan 0–3 speed measurement.
03	Fan 4–7 Divisor	55h	Sets oscillator frequency for Fan 4–7 speed measurement.
04	DAC Control	FFh	Contains value for fan speed DAC (analog fan speed control) or minimum value for automatic fan speed control.
05	PWM Control	FFh	Contains value for PWM fan speed control or minimum value for automatic fan speed control.
06	EEPROM Register	100h	For factory use only.
07	Configuration Register	300h	Configuration register for THERM, V _{REF} and GPIO16.
08	GPIO Config 1	00h	Configures GPIO0 to GPIO3 as input or output and as active high or active low.
09	GPIO Config 2	00h	Configures GPIO4 to GPIO7 as input or output and as active high or active low.
0A	GPIO Config 3	00h	Configures GPIO8 to GPIO11 as input or output and as active high or active low.
0B	GPIO Config 4	00h	Configures GPIO12 to GPIO15 as input or output and as active high or active low.
0C	EEPROM Register 2	00h	For factory use only.
0D	Int Temp THERM Limit	37h (55°C)	High limit for THERM interrupt output based on internal temperature measurement.
0E	TDM1 THERM Limit	50h (80°C)	High limit for THERM interrupt output based on Remote Channel 1 (D1) temperature measurement.
0F	TDM2 THERM Limit	50h (80°C)	High limit for THERM interrupt output based on Remote Channel 2 (D2) temperature measurement.
10	Int Temp T _{MIN}	28h (40°C)	T _{MIN} value for automatic fan speed control based on internal temperature measurement.
11	TDM1 T _{MIN}	40h (64°C)	T _{MIN} value for automatic fan speed control based on Remote Channel 1 (D1) temperature measurement.
12	TDM2 T _{MIN}	40h (64°C)	T _{MIN} value for automatic fan speed control based on Remote Channel 2 (D2) temperature measurement.
13	EEPROM Register 3	00h	Configures EEPROM for read/write/erase, etc.
14	Test Register 1	00h	Manufacturer's test register.
15	Test Register 2	00h	For manufacturer's use only.
16	Manufacturer's ID	41h	Contains manufacturer's ID code.
17	Revision	4xh	Contains code for major and minor revisions.
18	Mask Register 1	00h	Interrupt mask register for temperature and supply voltage faults.
19	Mask Register 2	00h	Interrupt mask register for analog input faults.
1A	Mask Register 3	00h	Interrupt mask register for fan faults.
1B	Mask Register 4	00h	Interrupt mask register for local temp, V _{BAT} , A _{INB} , THERM, AFC, CI and GPIO16.
1C	Mask Register 5	00h	Interrupt mask register for GPIO0 to GPIO7.
1D	Mask Register 6	00h	Interrupt mask register for GPIO8 to GPIO15.
1E	Int Temp Offset	00h	Offset register for internal temperature measurement.
1F	Int Temp Value	00h	Measured temperature from on-chip sensor.
20	Status Register 1	00h	Interrupt status register for external temp and supply voltage faults.
21	Status Register 2	00h	Interrupt status register for analog input faults.
22	Status Register 3	00h	Interrupt status register for fan faults.

ADM1026

Table 13. LIST OF REGISTERS

Hex Address	Name	Power-on Value	Description
23	Status Register 4	00h	Interrupt status register for local temp, V _{BAT} , A _{IN8} , THERM, AFC, CI, and GPIO16.
24	Status Register 5	00h	Interrupt status register for GPIO0 to GPIO7.
25	Status Register 6	00h	Interrupt status register for GPIO8 to GPIO15.
26	V _{BAT} Value	00h	Measured value of V _{BAT} .
27	A _{IN8} Value	00h	Measured value of A _{IN8} .
28	TDM1 Value	00h	Measured value of remote temperature channel 1 (D1).
29	TDM2/A _{IN9} Value	00h	Measured value of remote temperature channel 2 (D2) or A _{IN9} .
2A	3.3 V STBY Value	00h	Measured value of 3.3 V STBY.
2B	3.3 V MAIN Value	00h	Measured value of 3.3 V MAIN.
2C	+5.0 V Value	00h	Measured value of +5.0 V supply.
2D	V _{CCP} Value	00h	Measured value of processor core voltage.
2E	+12 V Value	00h	Measured value of +12 V supply.
2F	-12 V Value	00h	Measured value of -12 V supply.
30	A _{IN0} Value	00h	Measured value of A _{IN0} .
31	A _{IN1} Value	00h	Measured value of A _{IN1} .
32	A _{IN2} Value	00h	Measured value of A _{IN2} .
33	A _{IN3} Value	00h	Measured value of A _{IN3} .
34	A _{IN4} Value	00h	Measured value of A _{IN4} .
35	A _{IN5} Value	00h	Measured value of A _{IN5} .
36	A _{IN6} Value	00h	Measured value of A _{IN6} .
37	A _{IN7} Value	00h	Measured value of A _{IN7} .
38	FAN0 Value	00h	Measured speed of Fan 0.
39	FAN1 Value	00h	Measured speed of Fan 1.
3A	FAN2 Value	00h	Measured speed of Fan 2.
3B	FAN3 Value	00h	Measured speed of Fan 3.
3C	FAN4 Value	00h	Measured speed of Fan 4.
3D	FAN5 Value	00h	Measured speed of Fan 5.
3E	FAN6 Value	00h	Measured speed of Fan 6.
3F	FAN7 Value	00h	Measured speed of Fan 7.
40	TDM1 High Limit	64h (100°C)	High limit for Remote Temperature Channel 1 (D1) measurement.
41	TDM2/A _{IN9} High Limit	64h (100°C)	High limit for Remote Temperature Channel 2 (D2) or A _{IN9} measurement.
42	3.3 V STBY High Limit	FFh	High limit for 3.3 V STBY measurement.
43	3.3 V MAIN High Limit	FFh	High limit for 3.3 V MAIN measurement.
44	+5.0 V High Limit	FFh	High limit for +5.0 V supply measurement.
45	V _{CCP} High Limit	FFh	High limit for processor core voltage measurement.
46	+12 V High Limit	FFh	High limit for +12 V supply measurement.
47	-12 V High Limit	FFh	High limit for -12 V supply measurement.
48	TDM1 Low Limit	80h	Low limit for Remote Temperature Channel 1 (D1) measurement.
49	TDM2/A _{IN9} Low Limit	80h	Low limit for Remote Temperature Channel 2 (D2) or A _{IN9} measurement.
4A	3.3 V STBY Low Limit	00h	Low limit for 3.3 V STBY measurement.
4B	3.3 V MAIN Low Limit	00h	Low limit for 3.3 V MAIN measurement.
4C	+5.0 V Low Limit	00h	Low limit for +5.0 V supply.
4D	V _{CCP} Low Limit	00h	Low limit for processor core voltage measurement.
4E	+12 V Low Limit	00h	Low limit for +12 V supply measurement.
4F	-12 V Low Limit	00h	Low limit for -12 V supply measurement.
50	A _{IN0} High Limit	FFh	High limit for A _{IN0} measurement.
51	A _{IN1} High Limit	FFh	High limit for A _{IN1} measurement.

ADM1026

Table 13. LIST OF REGISTERS

Hex Address	Name	Power-on Value	Description
52	A _{IN2} High Limit	FFh	High limit for A _{IN2} measurement.
53	A _{IN3} High Limit	FFh	High limit for A _{IN3} measurement.
54	A _{IN4} High Limit	FFh	High limit for A _{IN4} measurement.
55	A _{IN5} High Limit	FFh	High limit for A _{IN5} measurement.
56	A _{IN6} High Limit	FFh	High limit for A _{IN6} measurement.
57	A _{IN7} High Limit	FFh	High limit for A _{IN7} measurement.
58	A _{IN0} Low Limit	00h	Low limit for A _{IN0} measurement.
59	A _{IN1} Low Limit	00h	Low limit for A _{IN1} measurement.
5A	A _{IN2} Low Limit	00h	Low limit for A _{IN2} measurement.
5B	A _{IN3} Low Limit	00h	Low limit for A _{IN3} measurement.
5C	A _{IN4} Low Limit	00h	Low limit for A _{IN4} measurement.
5D	A _{IN5} Low Limit	00h	Low limit for A _{IN5} measurement.
5E	A _{IN6} Low Limit	00h	Low limit for A _{IN6} measurement.
5F	A _{IN7} Low Limit	00h	Low limit for A _{IN7} measurement.
60	FAN0 High Limit	FFh	High limit for Fan 0 speed measurement (no low limit).
61	FAN1 High Limit	FFh	High limit for Fan 1 speed measurement (no low limit).
62	FAN2 High Limit	FFh	High limit for Fan 2 speed measurement (no low limit).
63	FAN3 High Limit	FFh	High limit for Fan 3 speed measurement (no low limit).
64	FAN4 High Limit	FFh	High limit for Fan 4 speed measurement (no low limit).
65	FAN5 High Limit	FFh	High limit for Fan 5 speed measurement (no low limit).
66	FAN6 High Limit	FFh	High limit for Fan 6 speed measurement (no low limit).
67	FAN7 High Limit	FFh	High limit for Fan 7 speed measurement (no low limit).
68	Int. Temp. High Limit	50h (80°C)	High limit for local temperature measurement.
69	Int. Temp. Low Limit	80h	Low limit for local temperature measurement.
6A	V _{BAT} High Limit	FFh	High limit for V _{BAT} measurement.
6B	V _{BAT} Low Limit	00h	Low limit for V _{BAT} measurement.
6C	A _{IN8} High Limit	FFh	High limit for A _{IN8} measurement.
6D	A _{IN8} Low Limit	00h	Low limit for A _{IN8} measurement.
6E	Ext1 Temp Offset	00h	Offset register for Remote Temperature Channel 1.
6F	Ext2 Temp Offset	00h	Offset register for Remote Temperature Channel 2.

ADM1026

Detailed Register Descriptions

Table 14. REGISTER 00H, CONFIGURATION REGISTER 1 (POWER-ON DEFAULT 00H)

Bit	Name	R/W	Description
0	Monitor = 0	R/W	When this bit is set the ADM1026 monitors all voltage, temperature and fan channels in a round robin manner.
1	Int Enable = 0	R/W	When this bit is set, the $\overline{\text{INT}}$ output pin is enabled.
2	Int Clear = 0	R/W	Setting this bit clears an interrupt from the voltage, temperature or fan speed channels. Because GPIO interrupts are level triggered, this bit has no effect on interrupts originating from GPIO channels. This bit is cleared by writing a 0 to it. If in monitoring mode voltages, temperatures and fan speeds continue to be monitored after writing to this bit to clear an interrupt, so an interrupt may be set again on the next monitoring cycle.
3	Enable Voltage/Ext2 = 0	R/W	When this bit is 1, the ADM1026 monitors voltage (A_{IN8} and A_{IN9}) on Pins 28 and 27, respectively. When this bit is 0, the ADM1026 monitors a second thermal diode temperature channel, D2, on these pins. If the second thermal diode channel is not being used, it is recommended that the bit be set to 1.
4	Enable $\overline{\text{THERM}}$ = 0	R/W	When this bit is 1, the $\overline{\text{THERM}}$ pin (Pin 42) is asserted (go low) if any of the THERM limits are exceeded. If THERM is pulled low as an input, the DAC and PWM outputs are forced to full scale until THERM is taken high.
5	Enable DAC AFC = 0	R/W	When this bit is 1, the DAC output is enabled for automatic fan speed control (AFC) based on temperature. When this bit is 0, the DAC Output reflects the value in Reg 04h, the DAC Control Register.
6	Enable PWM AFC = 0	R/W	When this bit is 1, the PWM output is enabled for automatic fan speed control (AFC) based on temperature. When this bit is 0, the PWM Output reflects the value in Reg 05h, the PWM Control Register.
7	Software Reset = 0	R/W	Writing a 1 to this bit restores all registers to the power-on defaults. This bit is cleared by writing a 0 to it. For more info, see the Software Reset Function section.

Table 15. REGISTER 01H, CONFIGURATION REGISTER 2 (POWER-ON DEFAULT 00H)

Bit	Name	R/W	Description
0	Enable GPIO0/Fan0 = 0	R/W	When this bit is 1, Pin 3 is enabled as a general-purpose I/O pin (GPIO0), otherwise it is a fan tach measurement input (Fan 0).
1	Enable GPIO1/Fan1 = 0	R/W	When this bit is 1, Pin 4 is enabled as a general-purpose I/O pin (GPIO1), otherwise it is a fan tach measurement input (Fan 1).
2	Enable GPIO2/Fan2 = 0	R/W	When this bit is 1, Pin 5 is enabled as a general-purpose I/O pin (GPIO2), otherwise it is a fan tach measurement input (Fan 2).
3	Enable GPIO3/Fan3 = 0	R/W	When this bit is 1, Pin 6 is enabled as a general-purpose I/O pin (GPIO3), otherwise it is a fan tach measurement input (Fan 3).
4	Enable GPIO4/Fan4 = 0	R/W	When this bit is 1, Pin 9 is enabled as a general-purpose I/O pin (GPIO4), otherwise it is a fan tach measurement input (Fan 4).
5	Enable GPIO5/Fan5 = 0	R/W	When this bit is 1, Pin 10 is enabled as a general-purpose I/O pin (GPIO5), otherwise it is a fan tach measurement input (Fan 5).
6	Enable GPIO6/Fan6 = 0	R/W	When this bit is 1, Pin 11 is enabled as a general-purpose I/O pin (GPIO6), otherwise it is a fan tach measurement input (Fan 6).
7	Enable GPIO7/Fan7 = 0	R/W	When this bit is 1, Pin 12 is enabled as a general-purpose I/O pin (GPIO7), otherwise it is a fan tach measurement input (Fan 7).

ADM1026

Table 16. REGISTER 02H, FANS 0 TO 3 FAN DIVISOR REGISTER (POWER-ON DEFAULT 55H)

Bit	Name	R/W	Description			
1–0	Fan 0 Divisor	R/W	Sets the oscillator prescaler division ratio for Fan 0 speed measurement. The division ratios, oscillator frequencies, and typical fan speeds (based on 2 tach pulses per revolution) are as follows:			
			Code	Divide By:	Oscillator Frequency (kHz)	Fan Speed (RPM)
			00	1	22.5	8800, nominal, for count of 153
			01	2	11.25	4400, nominal, for count of 153
			10	4	5.62	2200, nominal, for count of 153
11	8	2.81	1100, nominal, for count of 153			
3–2	Fan 1 Divisor	R/W	Same as Fan 0			
5–4	Fan 2 Divisor	R/W	Same as Fan 0			
7–6	Fan 3 Divisor	R/W	Same as Fan 0			

Table 17. REGISTER 03H, FANS 4 TO 7 FAN DIVISOR REGISTER (POWER-ON DEFAULT 55H)

Bit	Name	R/W	Description			
1–0	Fan 4 Divisor	R/W	Sets the oscillator prescaler division ratio for Fan 4 speed measurement. The division ratios, oscillator frequencies, and typical fan speeds (based on 2 tach pulses per revolution) are as follows:			
			Code	Divide By:	Oscillator Frequency (kHz)	Fan Speed (RPM)
			00	1	22.5	8800, nominal, for count of 153
			01	2	11.25	4400, nominal, for count of 153
			10	4	5.62	2200, nominal, for count of 153
11	8	2.81	1100, nominal, for count of 153			
3–2	Fan 5 Divisor	R/W	Same as Fan 4			
5–4	Fan 6 Divisor	R/W	Same as Fan 4			
7–6	Fan 7 Divisor	R/W	Same as Fan 4			

Table 18. REGISTER 04H, DAC CONFIGURATION REGISTER (POWER-ON DEFAULT FFH)

Bit	Name	R/W	Description
7–0	DAC Control	R/W	This register contains the value to which the fan speed DAC is programmed in normal mode, or the 4 MSBs contain the minimum fan speed in auto fan speed control mode.

Table 19. REGISTER 05H, PWM CONTROL REGISTER (POWER-ON DEFAULT FFH)

Bit	Name	R/W	Description
7–4	PWM Control	R/W	This register contains the value to which the PWM fan speed is programmed in normal mode, or the 4 MSBs contain the minimum fan speed in auto fan speed control mode. 0000 = 0% Duty Cycle 0001 = 7% Duty Cycle 0101 = 33% Duty Cycle 0110 = 40% Duty Cycle 0111 = 47% Duty Cycle 1110 = 93% Duty Cycle 1111 = 100% Duty Cycle
3–0	Unused	R	Undefined

Table 20. REGISTER 06H, EEPROM REGISTER 1 (POWER-ON DEFAULT 00H)

Bit	Name	R/W	Description
7–0	Factory Use	R/W	For factory use only. Do not write to this register.

ADM1026

Table 21. REGISTER 07H, CONFIGURATION REGISTER 3 (POWER-ON DEFAULT 00H)

Bit	Name	R/W	Description
0	Enable GPIO16/ THERM = 0	R/W	When this bit is 1, Pin 42 is enabled as a general-purpose I/O pin (GPIO16); otherwise it is the THERM output.
1	CI Clear = 0	R/W	Writing a 1 to this bit clears the CI latch. This bit is cleared by writing a 0 to it.
2	V _{REF} Select = 0	R/W	When this bit is 0, V _{REF} (Pin 24) outputs 1.82 V, otherwise, it outputs 2.5 V.
5-3	Unused	R	Undefined, reads back 0.
6	GPIO16 Direction	R/W	When this bit is 0, GPIO16 is configured as an input; otherwise, it is an output.
7	GPIO16 Polarity	R/W	When this bit is 0, GPIO16 is active low; otherwise, it is active high.

Table 22. REGISTER 08H, GPIO CONFIGURATION REGISTER 1 (POWER-ON DEFAULT 00H)

Bit	Name	R/W	Description
0	GPIO0 Direction	R/W	When this bit is 0, GPIO0 is configured as an input; otherwise, it is an output.
1	GPIO0 Polarity	R/W	When this bit is 0, GPIO0 is active low; otherwise it is active high.
2	GPIO1 Direction	R/W	When this bit is 0, GPIO1 is configured as an input; otherwise, it is an output.
3	GPIO1 Polarity	R/W	When this bit is 0, GPIO1 is active low; otherwise it is active high.
4	GPIO2 Direction	R/W	When this bit is 0, GPIO2 is configured as an input; otherwise, it is an output.
5	GPIO2 Polarity	R/W	When this bit is 0, GPIO2 is active low; otherwise, it is active high.
6	GPIO3 Direction	R/W	When this bit is 0, GPIO3 is configured as an input; otherwise, it is an output.
7	GPIO3 Polarity	R/W	When this bit is 0, GPIO3 is active low; otherwise, it is active high.

Table 23. REGISTER 09H, GPIO CONFIGURATION REGISTER 2 (POWER-ON DEFAULT 00H)

Bit	Name	R/W	Description
0	GPIO4 Direction	R/W	When this bit is 0, GPIO4 is configured as an input; otherwise, it is an output.
1	GPIO4 Polarity	R/W	When this bit is 0, GPIO4 is active low; otherwise, it is active high.
2	GPIO5 Direction	R/W	When this bit is 0, GPIO5 is configured as an input; otherwise, it is an output.
3	GPIO5 Polarity	R/W	When this bit is 0, GPIO5 is active low; otherwise, it is active high.
4	GPIO6 Direction	R/W	When this bit is 0, GPIO6 is configured as an input; otherwise, it is an output.
5	GPIO6 Polarity	R/W	When this bit is 0, GPIO6 is active low; otherwise, it is active high.
6	GPIO7 Direction	R/W	When this bit is 0, GPIO7 is configured as an input; otherwise, it is an output.
7	GPIO7 Polarity	R/W	When this bit is 0, GPIO7 is active low; otherwise, it is active high.

Table 24. REGISTER 0AH, GPIO CONFIGURATION REGISTER 3 (POWER-ON DEFAULT 00H)

Bit	Name	R/W	Description
0	GPIO8 Direction	R/W	When this bit is 0, GPIO8 is configured as an input; otherwise, it is an output.
1	GPIO8 Polarity	R/W	When this bit is 0, GPIO8 is active low; otherwise, it is active high.
2	GPIO9 Direction	R/W	When this bit is 0, GPIO9 is configured as an input; otherwise, it is an output.
3	GPIO9 Polarity	R/W	When this bit is 0, GPIO9 is active low; otherwise, it is active high.
4	GPIO10 Direction	R/W	When this bit is 0, GPIO10 is configured as an input; otherwise, it is an output.
5	GPIO10 Polarity	R/W	When this bit is 0, GPIO10 is active low; otherwise, it is active high.
6	GPIO11 Direction	R/W	When this bit is 0, GPIO11 is configured as an input; otherwise, it is an output.
7	GPIO11 Polarity	R/W	When this bit is 0, GPIO11 is active low; otherwise, it is active high.

Table 25. REGISTER 0BH, GPIO CONFIGURATION REGISTER 4 (POWER-ON DEFAULT 00H)

Bit	Name	R/W	Description
0	GPIO12 Direction	R/W	When this bit is 0, GPIO12 is configured as an input; otherwise, it is an output.
1	GPIO12 Polarity	R/W	When this bit is 0, GPIO12 is active low; otherwise, it is active high.
2	GPIO13 Direction	R/W	When this bit is 0, GPIO13 is configured as an input; otherwise, it is an output.
3	GPIO13 Polarity	R/W	When this bit is 0, GPIO13 is active low; otherwise, it is active high.
4	GPIO14 Direction	R/W	When this bit is 0, GPIO14 is configured as an input; otherwise, it is an output.
5	GPIO14 Polarity	R/W	When this bit is 0, GPIO14 is active low; otherwise, it is active high.
6	GPIO15 Direction	R/W	When this bit is 0, GPIO15 is configured as an input; otherwise, it is an output.
7	GPIO15 Polarity	R/W	When this bit is 0, GPIO15 is active low; otherwise, it is active high.

Table 26. REGISTER 0CH, EEPROM CONFIGURATION REGISTER 2 (POWER-ON DEFAULT 00H)

Bit	Name	R/W	Description
7-0	Factory Use	R	For factory use only. Do not write to this register.

Table 27. REGISTER 0DH, INTERNAL TEMPERATURE THERM LIMIT (POWER-ON DEFAULT, 37H 55°C)

Bit	Name	R/W	Description
7-0	Int Temp THERM Limit	R/W	This register contains the THERM limit for the internal temperature channel. Exceeding this limit causes the THERM output pin to be asserted.

Table 28. REGISTER 0EH, TDM1 THERM LIMIT (POWER-ON DEFAULT, 50H 80°C)

Bit	Name	R/W	Description
7-0	TDM1 THERM Limit	R/W	This register contains the THERM limit for the TDM1 temperature channel. Exceeding this limit causes the THERM output pin to be asserted.

Table 29. REGISTER 0FH, TDM2 THERM LIMIT (POWER-ON DEFAULT, 50H 80°C)

Bit	Name	R/W	Description
7-0	TDM2 THERM Limit	R/W	This register contains the THERM limit for the TDM2 temperature channel. Exceeding this limit causes the THERM output pin to be asserted.

Table 30. REGISTER 10H, INTERNAL TEMPERATURE T_{MIN} (POWER-ON DEFAULT, 28H 40°C)

Bit	Name	R/W	Description
7-0	Internal Temp T _{MIN}	R/W	This register contains the T _{MIN} value for automatic fan speed control based on the internal temperature channel.

Table 31. REGISTER 11H, TDM1 TEMPERATURE T_{MIN} (POWER-ON DEFAULT, 40H 64°C)

Bit	Name	R/W	Description
7-0	TDM1 Temp T _{MIN}	R/W	This register contains the T _{MIN} value for automatic fan speed control based on the TDM1 temperature channel.

Table 32. REGISTER 12H, TDM2 TEMPERATURE T_{MIN} (POWER-ON DEFAULT, 40H 64°C)

Bit	Name	R/W	Description
7-0	TDM2 Temp T _{MIN}	R/W	This register contains the T _{MIN} value for automatic fan speed control based on the TDM2 temperature channel.

ADM1026

Table 33. REGISTER 13H, EEPROM REGISTER 3 (POWER-ON DEFAULT, 00H)

Bit	Name	R/W	Description
0	Read	R/W	Setting this bit puts the EEPROM into read mode.
1	Write	R/W	Setting this bit puts the EEPROM in write (program) mode.
2	Erase	R/W	Setting this bit puts the EEPROM into erase mode.
3	Write Protect	R/W Once	Setting this bit protects the EEPROM against accidental writing or erasure. This bit can write once and only be cleared by a power-on reset.
4	Test Mode Bit 0	R/W	Test mode bits. For factory use only
5	Test Mode Bit 1	R/W	Test mode bits. For factory use only.
6	Test Mode Bit 2	R/W	Test mode bits. For factory use only
7	Clock Extend	R/W	Setting this bit enables SMBus clock extension. The ADM1026 can pull SCL low to extend the clock pulse if it cannot accept any more data. It is recommended to set this bit to 1 to extend the clock pulse during repeated EEPROM write or block write operations.

Table 34. REGISTER 14H, MANUFACTURER'S TEST REGISTER 1 (POWER-ON DEFAULT, 00H)

Bit	Name	R/W	Description
7-0	Manufacturer's Test 1	R/W	This register is used by the manufacturer for test purposes. It should not be read from or written to in normal operation.

Table 35. REGISTER 15H, MANUFACTURER'S TEST REGISTER 2 (POWER-ON DEFAULT, 00H)

Bit	Name	R/W	Description
7-0	Manufacturer's Test 2	R/W	This register is used by the manufacturer for test purposes. It should not be read from or written to in normal operation.

Table 36. REGISTER 16H, MANUFACTURER'S ID (POWER-ON DEFAULT, 041H)

Bit	Name	R/W	Description
7-0	Manufacturer ID Code	R/W	This register contains the manufacturer's ID code.

Table 37. REGISTER 17H, REVISION REGISTER (POWER-ON DEFAULT, 4XH)

Bit	Name	R/W	Description
3-0	Minor Revision Code	R	This nibble contains the manufacturer's code for minor revisions to the device. Rev 1 = 0h, Rev 2 = 1h, and so on.
7-4	Major Revision Code	R	This nibble denotes the generation of the device. For the ADM1026, this nibble reads 4h.

Table 38. REGISTER 18H, MASK REGISTER 1 (POWER-ON DEFAULT, 00H)

Bit	Name	R/W	Description
0	Ext1 Temp Mask = 0	R/W	When this bit is set, interrupts generated on the Ext1 temperature channel are masked out.
1	Ext2 Temp	R/W	When this bit is set, interrupts generated on the Ext2/A _{IN9} channel are masked out.
2	3.3 V STBY Mask = 0	R/W	When this bit is set, interrupts generated on the 3.3 V STBY voltage channel are masked out.
3	3.3 V MAIN Mask = 0	R/W	When this bit is set, interrupts generated on the 3.3 V MAIN voltage channel are masked out.
4	+5.0 V Mask = 0	R/W	When this bit is set, interrupts generated on the +5.0 V voltage channel are masked out.
5	V _{CCP} Mask = 0	R/W	When this bit is set, interrupts generated on the V _{CCP} voltage channel are masked out.
6	+12 V Mask = 0	R/W	When this bit is set, interrupts generated on the +12 V voltage channel are masked out.
7	-12 V Mask = 0	R/W	When this bit is set, interrupts generated on the -12 V voltage channel are masked out.

Table 39. REGISTER 19H, MASK REGISTER 2 (POWER-ON DEFAULT, 00H)

Bit	Name	R/W	Description
0	A _{IN0} Mask = 0	R/W	When this bit is set, interrupts generated on the A _{IN0} voltage channel are masked out.
1	A _{IN1} Mask = 0	R/W	When this bit is set, interrupts generated on the A _{IN1} voltage channel are masked out.
2	A _{IN2} Mask = 0	R/W	When this bit is set, interrupts generated on the A _{IN2} voltage channel are masked out.
3	A _{IN3} Mask = 0	R/W	When this bit is set, interrupts generated on the A _{IN3} voltage channel are masked out.
4	A _{IN4} Mask = 0	R/W	When this bit is set, interrupts generated on the A _{IN4} voltage channel are masked out.
5	A _{IN5} Mask = 0	R/W	When this bit is set, interrupts generated on the A _{IN5} voltage channel are masked out.
6	A _{IN6} Mask = 0	R/W	When this bit is set, interrupts generated on the A _{IN6} voltage channel are masked out.
7	A _{IN7} Mask = 0	R/W	When this bit is set, interrupts generated on the A _{IN7} voltage channel are masked out.

Table 40. REGISTER 1AH, MASK REGISTER 3 (POWER-ON DEFAULT, 00H)

Bit	Name	R/W	Description
0	FAN0 Mask = 0	R/W	When this bit is set, interrupts generated on the FAN0 tach channel are masked out.
1	FAN1 Mask = 0	R/W	When this bit is set, interrupts generated on the FAN1 tach channel are masked out.
2	FAN2 Mask = 0	R/W	When this bit is set, interrupts generated on the FAN2 tach channel are masked out.
3	FAN3 Mask = 0	R/W	When this bit is set, interrupts generated on the FAN3 tach channel are masked out.
4	FAN4 Mask = 0	R/W	When this bit is set, interrupts generated on the FAN4 tach channel are masked out.
5	FAN5 Mask = 0	R/W	When this bit is set, interrupts generated on the FAN5 tach channel are masked out.
6	FAN6 Mask = 0	R/W	When this bit is set, interrupts generated on the FAN6 tach channel are masked out.
7	FAN7 Mask = 0	R/W	When this bit is set, interrupts generated on the FAN7 tach channel are masked out.

Table 41. REGISTER 1BH, MASK REGISTER 4 (POWER-ON DEFAULT, 00H)

Bit	Name	R/W	Description
0	Int Temp Mask = 0	R/W	When this bit is set, interrupts generated on the internal temperature channel are masked out.
1	V _{BAT} Mask = 0	R/W	When this bit is set, interrupts generated on the V _{BAT} voltage channel are masked out.
2	A _{IN8} Mask = 0	R/W	When this bit is set, interrupts generated on the A _{IN8} voltage channel are masked out.
3	THERM Mask = 0	R/W	When this bit is set, interrupts generated from THERM events are masked out.
4	AFC Mask = 0	R/W	When this bit is set, interrupts generated from automatic fan control events are masked out.
5	Unused	R/W	Unused. Reads back 0.
6	CI Mask = 0	R/W	When this bit is set, interrupts generated by the chassis intrusion input are masked out.
7	GPIO16 Mask = 0	R/W	When this bit is set, interrupts generated on the GPIO16 channel are masked out.

Table 42. REGISTER 1CH, MASK REGISTER 5 (POWER-ON DEFAULT, 00H)

Bit	Name	R/W	Description
0	GPIO0 Mask = 0	R/W	When this bit is set, interrupts generated on the GPIO0 channel are masked out.
1	GPIO1 Mask = 0	R/W	When this bit is set, interrupts generated on the GPIO1 channel are masked out.
2	GPIO2 Mask = 0	R/W	When this bit is set, interrupts generated on the GPIO2 channel are masked out.
3	GPIO3 Mask = 0	R/W	When this bit is set, interrupts generated on the GPIO3 channel are masked out.
4	GPIO4 Mask = 0	R/W	When this bit is set, interrupts generated on the GPIO4 channel are masked out.
5	GPIO5 Mask = 0	R/W	When this bit is set, interrupts generated on the GPIO5 channel are masked out.
6	GPIO6 Mask = 0	R/W	When this bit is set, interrupts generated on the GPIO6 channel are masked out.
7	GPIO7 Mask = 0	R/W	When this bit is set, interrupts generated on the GPIO7 channel are masked out.

Table 43. REGISTER 1DH, MASK REGISTER 6 (POWER-ON DEFAULT, 00H)

Bit	Name	R/W	Description
0	GPIO8 Mask = 0	R/W	When this bit is set, interrupts generated on the GPIO8 channel are masked out.
1	GPIO9 Mask = 0	R/W	When this bit is set, interrupts generated on the GPIO9 channel are masked out.
2	GPIO10 Mask = 0	R/W	When this bit is set, interrupts generated on the GPIO10 channel are masked out.
3	GPIO11 Mask = 0	R/W	When this bit is set, interrupts generated on the GPIO11 channel are masked out.
4	GPIO12 Mask = 0	R/W	When this bit is set, interrupts generated on the GPIO12 channel are masked out.
5	GPIO13 Mask = 0	R/W	When this bit is set, interrupts generated on the GPIO13 channel are masked out.
6	GPIO14 Mask = 0	R/W	When this bit is set, interrupts generated on the GPIO14 channel are masked out.
7	GPIO15 Mask = 0	R/W	When this bit is set, interrupts generated on the GPIO15 channel are masked out.

Table 44. REGISTER 1EH, INT TEMP OFFSET (POWER-ON DEFAULT, 00H)

Bit	Name	R/W	Description
7-0	Int Temp Offset	R/W	This register contains the offset value for the internal temperature channel, a twos complement result before it is stored or compared to limits. In this way, a sort of one-point calibration can be done whereby the whole transfer function of the channel can be moved up or down. From a software point of view, this may be a very simple method to vary the characteristics of the measurement channel if the thermal characteristics change for any reason (for instance from one chassis to another), if the measurement point is moved, if a plug-in card is inserted or removed, and so on.

Table 45. REGISTER 1FH, INT TEMP MEASURED VALUE (POWER-ON DEFAULT, 00H)

Bit	Name	R/W	Description
7-0	Int Temp Value	R	This register contains the measured value of the internal temperature channel.

Table 46. REGISTER 20H, STATUS REGISTER 1 (POWER-ON DEFAULT, 00H)

Bit	Name	R/W	Description
0	Ext1 Temp Status = 0	R	1, if Ext1 value is above the high limit or below the low limit on the previous conversion cycle; 0 otherwise. This bit is set (once only) if a THERM mode is engaged as a result of Ext1 temp readings exceeding the Ext1 THERM limit. This bit is also set (once only) if THERM mode is disengaged as a result of Ext1 temperature readings going 5°C below Ext1 THERM limit.
1	Ext2 Temp Status = 0	R	1, if Ext 2 value (or A _{IN9} if in voltage measurement mode) is above the /A _{IN9} status = 0 high limit or below the low limit on the previous conversion cycle; 0 otherwise. This bit is set (once only) if a THERM mode is engaged as a result of Ext2 temperature readings exceeding the Ext2 THERM limit. This bit is also set (once only) if THERM mode is disengaged as a result of Ext2 temperature readings going 5°C below Ext2 THERM limit.
2	3.3 V STBY Status = 0	R	1, if 3.3 V STBY value is above the high limit or below the low limit on the previous conversion cycle; 0 otherwise.
3	3.3 V MAIN Status = 0	R	1, if 3.3 V MAIN value is above the high limit or below the low limit on the previous conversion cycle; 0 otherwise.
4	+5.0 V Status = 0	R	1, if +5.0 V value is above the high limit or below the low limit on the previous conversion cycle; 0 otherwise.
5	V _{CCP} Status = 0	R	1, if V _{CCP} value is above the high limit or below the low limit on the previous conversion cycle; 0 otherwise.
6	+12 V Status = 0	R	1, if +12 V value is above the high limit or below the low limit on the previous conversion cycle; 0 otherwise.
7	-12 V Status = 0	R	1, if -12 V value is above the high limit or below the low limit on the previous conversion cycle; 0 otherwise.

Table 47. REGISTER 21H, STATUS REGISTER 2 (POWER-ON DEFAULT, 00H)

Bit	Name	R/W	Description
0	A _{IN0} Status = 0	R	1, if A _{IN0} to A _{IN7} value is above the high limit or below the low limit on the previous conversion cycle; 0 otherwise.
1	A _{IN1} Status = 0	R	1, if A _{IN0} to A _{IN7} value is above the high limit or below the low limit on the previous conversion cycle; 0 otherwise.
2	A _{IN2} Status = 0	R	1, if A _{IN0} to A _{IN7} value is above the high limit or below the low limit on the previous conversion cycle; 0 otherwise.
3	A _{IN3} Status = 0	R	1, if A _{IN0} to A _{IN7} value is above the high limit or below the low limit on the previous conversion cycle; 0 otherwise.
4	A _{IN4} Status = 0	R	1, if A _{IN0} to A _{IN7} value is above the high limit or below the low limit on the previous conversion cycle; 0 otherwise.
5	A _{IN5} Status = 0	R	1, if A _{IN0} to A _{IN7} value is above the high limit or below the low limit on the previous conversion cycle; 0 otherwise.
6	A _{IN6} Status = 0	R	1, if A _{IN0} to A _{IN7} value is above the high limit or below the low limit on the previous conversion cycle; 0 otherwise.
7	A _{IN7} Status = 0	R	1, if A _{IN0} to A _{IN7} value is above the high limit or below the low limit on the previous conversion cycle; 0 otherwise.

Table 48. REGISTER 22H, STATUS REGISTER 3 (POWER-ON DEFAULT, 00H)

Bit	Name	R/W	Description
0	FAN0 Status 1 = 0	R	1, if FAN0 to FAN7 value is above the high limit on the previous conversion cycle; 0 otherwise.
1	FAN1 Status 1 = 0	R	1, if FAN0 to FAN7 value is above the high limit on the previous conversion cycle; 0 otherwise.
2	FAN2 Status 1 = 0	R	1, if FAN0 to FAN7 value is above the high limit on the previous conversion cycle; 0 otherwise.
3	FAN3 Status 1 = 0	R	1, if FAN0 to FAN7 value is above the high limit on the previous conversion cycle; 0 otherwise.
4	FAN4 Status 1 = 0	R	1, if FAN0 to FAN7 value is above the high limit on the previous conversion cycle; 0 otherwise.
5	FAN5 Status 1 = 0	R	1, if FAN0 to FAN7 value is above the high limit on the previous conversion cycle; 0 otherwise.
6	FAN6 Status 1 = 0	R	1, if FAN0 to FAN7 value is above the high limit on the previous conversion cycle; 0 otherwise.
7	FAN7 Status 1 = 0	R	1, if FAN0 to FAN7 value is above the high limit on the previous conversion cycle; 0 otherwise.

ADM1026

Table 49. REGISTER 23H, STATUS REGISTER 4 (POWER-ON DEFAULT, 00H)

Bit	Name	R/W	Description
0	$\overline{\text{INT}}$ Temp Status = 0	R	1, if $\overline{\text{INT}}$ value is above the high limit or below the low limit on the previous conversion cycle, 0 otherwise. This bit is set (once only) if a THERM mode is engaged as a result of INT temperature readings exceeding the $\overline{\text{INT}}$ THERM limit. This bit is also set (once only) if THERM mode is disengaged as a result of internal temperature readings going 5°C below Int THERM limit.
1	V _{BAT} Status = 0	R	1, if V _{BAT} value is above the high limit or below the low limit on the previous conversion cycle, 0 otherwise.
2	A _{IN8} Status = 0	R	1, if A _{IN8} value is above the high limit or below the low limit on the previous conversion cycle, 0 otherwise.
3	THERM Status = 0	R	This bit is set (once only) if a THERM mode is engaged as a result of temperature readings exceeding the THERM limits on any channel. This bit is also set (once only) if THERM mode is disengaged as a result of temperature readings going 5°C below THERM limits on any channel.
4	AFC Status = 0	R	This bit is set (once only) if the fan turns on when in automatic fan speed control (AFC) mode as a result of a temperature reading exceeding T _{MIN} on any channel. This bit is also set (once only) if the fan turns off when in automatic fan speed control mode.
5	Unused	R	Unused. Reads back 0.
6	CI Status = 0	R	This bit latches a chassis intrusion event.
7	GPIO16 Status = 0	R R/W	When GPIO16 is configured as an input, this bit is set when GPIO16 is asserted. (Asserted may be active high or active low depending on the setting in GPIO configuration register.) When GPIO16 is configured as an output, setting this bit asserts GPIO16. (Asserted may be active high or active low depending on setting in GPIO configuration register.)

ADM1026

Table 50. REGISTER 24H, STATUS REGISTER 5 (POWER-ON DEFAULT, 00H)

Bit	Name	R/W (Note 1)	Description
0	GPIO0 Status = 0	R R/W	When GPIO0 is configured as an input, this bit is set when GPIO0 is asserted. (Asserted may be active high or active low depending on setting of Bit 1 in GPIO Configuration Register 1.) When GPIO0 is configured as an output, setting this bit asserts GPIO0. (Asserted may be active high or active low depending on setting of Bit 1 in GPIO Configuration Register 1.)
1	GPIO1 Status = 0	R R/W	When GPIO1 is configured as an input, this bit is set when GPIO1 is asserted. (Asserted may be active high or active low depending on setting of Bit 3 in GPIO Configuration Register 1.) When GPIO1 is configured as an output, setting this bit asserts GPIO1. (Asserted may be active high or active low depending on setting of Bit 3 in GPIO Configuration Register 1.)
2	GPIO2 Status = 0	R R/W	When GPIO2 is configured as an input, this bit is set when GPIO2 is asserted. (Asserted may be active high or active low depending on setting of Bit 5 in GPIO Configuration Register 1.) When GPIO2 is configured as an output, setting this bit asserts GPIO2. (Asserted may be active high or active low depending on setting of Bit 5 in GPIO Configuration Register 1.)
3	GPIO3 Status = 0	R R/W	When GPIO3 is configured as an input, this bit is set when GPIO3 is asserted. (Asserted may be active high or active low depending on setting of Bit 7 in GPIO Configuration Register 1.) When GPIO3 is configured as an output, setting this bit asserts GPIO3. (Asserted may be active high or active low depending on setting of Bit 7 in GPIO Configuration Register 1.)
4	GPIO4 Status = 0	R R/W	When GPIO4 is configured as an input, this bit is set when GPIO4 is asserted. (Asserted may be active high or active low depending on setting of Bit 1 in GPIO Configuration Register 2.) When GPIO4 is configured as an output, setting this bit asserts GPIO4. (Asserted may be active high or active low depending on setting of Bit 1 in GPIO Configuration Register 2.)
5	GPIO5 Status = 0	R R/W	When GPIO5 is configured as an input, this bit is set when GPIO5 is asserted. (Asserted may be active high or active low depending on setting of Bit 3 in GPIO Configuration Register 2.) When GPIO5 is configured as an output, setting this bit asserts GPIO5. (Asserted may be active high or active low depending on setting of Bit 3 in GPIO Configuration Register 2.)
6	GPIO6 Status = 0	R R/W	When GPIO6 is configured as an input, this bit is set when GPIO6 is asserted. (Asserted may be active high or active low depending on setting of Bit 5 in GPIO Configuration Register 2.) When GPIO6 is configured as an output, setting this bit asserts GPIO6. (Asserted may be active high or active low depending on setting of Bit 5 in GPIO Configuration Register 2.)
7	GPIO7 Status = 0	R R/W	When GPIO7 is configured as an input, this bit is set when GPIO7 is asserted. (Asserted may be active high or active low depending on setting of Bit 7 in GPIO Configuration Register 2.) When GPIO7 is configured as an output, setting this bit asserts GPIO7. (Asserted may be active high or active low depending on setting of Bit 7 in GPIO Configuration Register 2.)

1. GPIO status bits can be written only when a GPIO pin is configured as output. Read-only otherwise.

ADM1026

Table 51. REGISTER 25H, STATUS REGISTER 6 (POWER-ON DEFAULT, 00H)

Bit	Name	R/W (Note 1)	Description
0	GPIO8 Status = 0	R R/W	When GPIO8 is configured as an input, this bit is set when GPIO8 is asserted. (Asserted may be active high or active low depending on setting of Bit 1 in GPIO Configuration Register 3.) When GPIO8 is configured as an output, setting this bit asserts GPIO8. (Asserted may be active high or active low depending on setting of Bit 1 in GPIO Configuration Register 3.)
1	GPIO9 Status = 0	R R/W	When GPIO9 is configured as an input, this bit is set when GPIO9 is asserted. (Asserted may be active high or active low depending on setting of Bit 3 in GPIO Configuration Register 3.) When GPIO9 is configured as an output, setting this bit asserts GPIO9. (Asserted may be active high or active low depending on setting of Bit 3 in GPIO Configuration Register 3.)
2	GPIO10 Status = 0	R R/W	When GPIO10 is configured as an input, this bit is set when GPIO10 is asserted. (Asserted may be active high or active low depending on setting of Bit 5 in GPIO Configuration Register 3.) When GPIO10 is configured as an output, setting this bit asserts GPIO10. (Asserted may be active high or active low depending on setting of Bit 5 in GPIO Configuration Register 3.)
3	GPIO11 Status = 0	R R/W	When GPIO11 is configured as an input, this bit is set when GPIO11 is asserted. (Asserted may be active high or active low depending on setting of Bit 7 in GPIO Configuration Register 3.) When GPIO11 is configured as an output, setting this bit asserts GPIO11. (Asserted may be active high or active low depending on setting of Bit 7 in GPIO Configuration Register 3.)
4	GPIO12 Status = 0	R R/W	When GPIO12 is configured as an input, this bit is set when GPIO12 is asserted. (Asserted may be active high or active low depending on setting of Bit 1 in GPIO Configuration Register 4.) When GPIO12 is configured as an output, setting this bit asserts GPIO12. (Asserted may be active high or active low depending on setting of Bit 1 in GPIO Configuration Register 4.)
5	GPIO13 Status = 0	R R/W	When GPIO13 is configured as an input, this bit is set when GPIO13 is asserted. (Asserted may be active high or active low depending on setting of Bit 3 in GPIO Configuration Register 4.) When GPIO13 is configured as an output, setting this bit asserts GPIO13. (Asserted may be active high or active low depending on setting of Bit 3 in GPIO Configuration Register 4.)
6	GPIO14 Status = 0	R R/W	When GPIO14 is configured as an input, this bit is set when GPIO14 is asserted. (Asserted may be active high or active low depending on setting of Bit 5 in GPIO Configuration Register 4.) When GPIO14 is configured as an output, setting this bit asserts GPIO14. (Asserted may be active high or active low depending on setting of Bit 5 in GPIO Configuration Register 4.)
7	GPIO15 Status = 0	R R/W	When GPIO15 is configured as an input, this bit is set when GPIO15 is asserted. (Asserted may be active high or active low depending on setting of Bit 7 in GPIO Configuration Register 4.) When GPIO15 is configured as an output, setting this bit asserts GPIO15. (Asserted may be active high or active low depending on setting of Bit 7 in GPIO Configuration Register 4.)

1. GPIO status bits can be written only when a GPIO pin is configured as output. Read-only otherwise.

Table 52. REGISTER 26H, V_{BAT} MEASURED VALUE (POWER-ON DEFAULT, 00H)

Bit	Name	R/W	Description
7-0	V _{BAT} Value	R	This register contains the measured value of the V _{BAT} analog input channel.

Table 53. REGISTER 27H, A_{IN8} MEASURED VALUE (POWER-ON DEFAULT, 00H)

Bit	Name	R/W	Description
7-0	A _{IN8} Value	R	This register contains the measured value of the A _{IN8} analog input channel.

ADM1026

Table 54. REGISTER 28H, EXT1 MEASURED VALUE (POWER-ON DEFAULT, 00H)

Bit	Name	R/W	Description
7-0	Ext1 Value	R	This register contains the measured value of the Ext1 Temp channel.

Table 55. REGISTER 29H, EXT2/A_{IN9} MEASURED VALUE (POWER-ON DEFAULT, 00H)

Bit	Name	R/W	Description
7-0	Ext2 Temp/ A _{IN9} Low Limit	R	This register contains the measured value of the Ext2 Temp/A _{IN9} channel depending on which bit is configured.

Table 56. REGISTER 2AH, 3.3 V STBY MEASURED VALUE (POWER-ON DEFAULT, 00H)

Bit	Name	R/W	Description
7-0	3.3 V STBY Value	R	This register contains the measured value of the 3.3 V STBY voltage.

Table 57. REGISTER 2BH, 3.3 V MAIN MEASURED VALUE (POWER-ON DEFAULT, 00H)

Bit	Name	R/W	Description
7-0	3.3 V MAIN Value	R	This register contains the measured value of the 3.3 V MAIN voltage.

Table 58. REGISTER 2CH, +5.0 V MEASURED VALUE (POWER-ON DEFAULT, 00H)

Bit	Name	R/W	Description
7-0	+5.0 V Value	R	This register contains the measured value of the +5.0 V analog input channel.

Table 59. REGISTER 2DH, V_{CCP} MEASURED VALUE (POWER-ON DEFAULT, 00H)

Bit	Name	R/W	Description
7-0	V _{CCP} Value	R	This register contains the measured value of the V _{CCP} analog input channel.

Table 60. REGISTER 2EH, +12 V MEASURED VALUE (POWER-ON DEFAULT, 00H)

Bit	Name	R/W	Description
7-0	+12 V Value	R	This register contains the measured value of the +12 V analog input channel.

Table 61. REGISTER 2FH, -12 V MEASURED VALUE (POWER-ON DEFAULT, 00H)

Bit	Name	R/W	Description
7-0	-12 V Value	R	This register contains the measured value of the -12 V analog input channel.

Table 62. REGISTER 30H, A_{IN0} MEASURED VALUE (POWER-ON DEFAULT, 00H)

Bit	Name	R/W	Description
7-0	A _{IN0} Value	R	This register contains the measured value of the A _{IN0} analog input channel.

Table 63. REGISTER 31H, A_{IN1} MEASURED VALUE (POWER-ON DEFAULT, 00H)

Bit	Name	R/W	Description
7-0	A _{IN1} Value	R	This register contains the measured value of the A _{IN1} analog input channel.

Table 64. REGISTER 32H, A_{IN2} MEASURED VALUE (POWER-ON DEFAULT, 00H)

Bit	Name	R/W	Description
7-0	A _{IN2} Value	R	This register contains the measured value of the A _{IN2} analog input channel.

ADM1026

Table 65. REGISTER 33H, A_{IN3} MEASURED VALUE (POWER-ON DEFAULT, 00H)

Bit	Name	R/W	Description
7-0	A _{IN3} Value	R	This register contains the measured value of the A _{IN3} analog input channel.

Table 66. REGISTER 34H, A_{IN4} MEASURED VALUE (POWER-ON DEFAULT, 00H)

Bit	Name	R/W	Description
7-0	A _{IN4} Value	R	This register contains the measured value of the A _{IN4} analog input channel.

Table 67. REGISTER 35H, A_{IN5} MEASURED VALUE (POWER-ON DEFAULT, 00H)

Bit	Name	R/W	Description
7-0	A _{IN5} Value	R	This register contains the measured value of the A _{IN5} analog input channel.

Table 68. REGISTER 36H, A_{IN6} MEASURED VALUE (POWER-ON DEFAULT, 00H)

Bit	Name	R/W	Description
7-0	A _{IN6} Value	R	This register contains the measured value of the A _{IN6} analog input channel.

Table 69. REGISTER 37H, A_{IN7} MEASURED VALUE (POWER-ON DEFAULT, 00H)

Bit	Name	R/W	Description
7-0	A _{IN7} Value	R	This register contains the measured value of the A _{IN7} analog input channel.

Table 70. REGISTER 38H, FAN0 MEASURED VALUE (POWER-ON DEFAULT, 00H)

Bit	Name	R/W	Description
7-0	FAN0 Value	R	This register contains the measured value of the FAN0 tach input channel.

Table 71. REGISTER 39H, FAN1 MEASURED VALUE (POWER-ON DEFAULT, 00H)

Bit	Name	R/W	Description
7-0	FAN1 Value	R	This register contains the measured value of the FAN1 tach input channel.

Table 72. REGISTER 3AH, FAN2 MEASURED VALUE (POWER-ON DEFAULT, 00H)

Bit	Name	R/W	Description
7-0	FAN2 Value	R	This register contains the measured value of the FAN2 tach input channel.

Table 73. REGISTER 3BH, FAN3 MEASURED VALUE (POWER-ON DEFAULT, 00H)

Bit	Name	R/W	Description
7-0	FAN3 Value	R	This register contains the measured value of the FAN3 tach input channel.

Table 74. REGISTER 3CH, FAN4 MEASURED VALUE (POWER-ON DEFAULT, 00H)

Bit	Name	R/W	Description
7-0	FAN4 Value	R	This register contains the measured value of the FAN4 tach input channel.

Table 75. REGISTER 3DH, FAN5 MEASURED VALUE (POWER-ON DEFAULT, 00H)

Bit	Name	R/W	Description
7-0	FAN5 Value	R	This register contains the measured value of the FAN5 tach input channel.

ADM1026

Table 76. REGISTER 3EH, FAN6 MEASURED VALUE (POWER-ON DEFAULT, 00H)

Bit	Name	R/W	Description
7-0	FAN6 Value	R	This register contains the measured value of the FAN6 tach input channel.

Table 77. REGISTER 3FH, FAN7 MEASURED VALUE (POWER-ON DEFAULT, 00H)

Bit	Name	R/W	Description
7-0	FAN7 Value	R	This register contains the measured value of the FAN7 tach input channel.

Table 78. REGISTER 40H, EXT1 HIGH LIMIT (POWER-ON DEFAULT 64H/100°C)

Bit	Name	R/W	Description
7-0	Ext1 High Limit	R/W	This register contains the high limit of the Ext1 Temp channel.

Table 79. REGISTER 41H, EXT2/A_{IN9} HIGH LIMIT (POWER-ON DEFAULT 64H/100°C)

Bit	Name	R/W	Description
7-0	Ext2 Temp/ A _{IN9} High Limit	R/W	This register contains the high limit of the Ext2 Temp/A _{IN9} channel depending on which one is configured.

Table 80. REGISTER 42H, 3.3 V STBY HIGH LIMIT (POWER-ON DEFAULT FFH)

Bit	Name	R/W	Description
7-0	3.3 V STBY High Limit	R/W	This register contains the high limit of the 3.3 V STBY analog input channel.

Table 81. REGISTER 43H, 3.3 V MAIN HIGH LIMIT (POWER-ON DEFAULT FFH)

Bit	Name	R/W	Description
7-0	3.3 V MAIN High Limit	R/W	This register contains the high limit of the 3.3 V MAIN analog input channel.

Table 82. REGISTER 44H, +5.0 V HIGH LIMIT (POWER-ON DEFAULT FFH)

Bit	Name	R/W	Description
7-0	+5.0 V High Limit	R/W	This register contains the high limit of the +5.0 V analog input channel.

Table 83. REGISTER 45H, V_{CCP} HIGH LIMIT (POWER-ON DEFAULT FFH)

Bit	Name	R/W	Description
7-0	V _{CCP} High Limit	R/W	This register contains the high limit of the V _{CCP} analog input channel.

Table 84. REGISTER 46H, +12 V HIGH LIMIT (POWER-ON DEFAULT FFH)

Bit	Name	R/W	Description
7-0	+12 V High Limit	R/W	This register contains the high limit of the +12 V analog input channel.

Table 85. REGISTER 47H, -12 V HIGH LIMIT (POWER-ON DEFAULT FFH)

Bit	Name	R/W	Description
7-0	-12 V High Limit	R/W	This register contains the high limit of the -12 V analog input channel.

Table 86. REGISTER 48H, EXT1 LOW LIMIT (POWER-ON DEFAULT 80H)

Bit	Name	R/W	Description
7-0	Ext1 Low Limit	R/W	This register contains the low limit of the Ext1 Temp channel.

ADM1026

Table 87. REGISTER 49H, EXT/A_{IN9} LOW LIMIT (POWER-ON DEFAULT 80H)

Bit	Name	R/W	Description
7-0	Ext2 Temp /A _{IN9} Low Limit	R/W	This register contains the low limit of the Ext2 Temp/A _{IN9} channel depending on which bit is configured.

Table 88. REGISTER 4AH, 3.3 V STBY LOW LIMIT (POWER-ON DEFAULT 00H)

Bit	Name	R/W	Description
7-0	3.3 V STBY Low Limit	R/W	This register contains the low limit of the 3.3 V STBY analog input channel.

Table 89. REGISTER 4BH, 3.3 V MAIN LOW LIMIT (POWER-ON DEFAULT 00H)

Bit	Name	R/W	Description
7-0	3.3 V MAIN Low Limit	R/W	This register contains the low limit of the 3.3 V MAIN analog input channel.

Table 90. REGISTER 4CH, +5.0 V LOW LIMIT (POWER-ON DEFAULT 00H)

Bit	Name	R/W	Description
7-0	+5.0 V Low Limit	R/W	This register contains the low limit of the +5.0 V analog input channel.

Table 91. REGISTER 4DH, V_{CCP} LOW LIMIT (POWER-ON DEFAULT 00H)

Bit	Name	R/W	Description
7-0	V _{CCP} Low Limit	R/W	This register contains the low limit of the V _{CCP} analog input channel.

Table 92. REGISTER 4EH, +12 V LOW LIMIT (POWER-ON DEFAULT 00H)

Bit	Name	R/W	Description
7-0	+12 V Low Limit	R/W	This register contains the low limit of the +12 V analog input channel.

Table 93. REGISTER 4FH, -12 V LOW LIMIT (POWER-ON DEFAULT 00H)

Bit	Name	R/W	Description
7-0	-12 V Low Limit	R/W	This register contains the low limit of the -12 V analog input channel.

Table 94. REGISTER 50H, A_{IN0} HIGH LIMIT (POWER-ON DEFAULT FFH)

Bit	Name	R/W	Description
7-0	A _{IN0} High Limit	R/W	This register contains the high limit of the A _{IN0} analog input channel.

Table 95. REGISTER 51H, A_{IN1} HIGH LIMIT (POWER-ON DEFAULT FFH)

Bit	Name	R/W	Description
7-0	A _{IN1} High Limit	R/W	This register contains the high limit of the A _{IN1} analog input channel.

Table 96. REGISTER 52H, A_{IN2} HIGH LIMIT (POWER-ON DEFAULT FFH)

Bit	Name	R/W	Description
7-0	A _{IN2} High Limit	R/W	This register contains the high limit of the A _{IN2} analog input channel.

Table 97. REGISTER 53H, A_{IN3} HIGH LIMIT (POWER-ON DEFAULT FFH)

Bit	Name	R/W	Description
7-0	A _{IN3} High Limit	R/W	This register contains the high limit of the A _{IN3} analog input channel.

ADM1026

Table 98. REGISTER 54H, A_{IN4} HIGH LIMIT (POWER-ON DEFAULT FFH)

Bit	Name	R/W	Description
7-0	A _{IN4} High Limit	R/W	This register contains the high limit of the A _{IN4} analog input channel.

Table 99. REGISTER 55H, A_{IN5} HIGH LIMIT (POWER-ON DEFAULT FFH)

Bit	Name	R/W	Description
7-0	A _{IN5} High Limit	R/W	This register contains the high limit of the A _{IN5} analog input channel.

Table 100. REGISTER 56H, A_{IN6} HIGH LIMIT (POWER-ON DEFAULT FFH)

Bit	Name	R/W	Description
7-0	A _{IN6} High Limit	R/W	This register contains the high limit of the A _{IN6} analog input channel.

Table 101. REGISTER 57H, A_{IN7} HIGH LIMIT (POWER-ON DEFAULT FFH)

Bit	Name	R/W	Description
7-0	A _{IN7} High Limit	R/W	This register contains the high limit of the A _{IN7} analog input channel.

Table 102. REGISTER 58H, A_{IN0} LOW LIMIT (POWER-ON DEFAULT 00H)

Bit	Name	R/W	Description
7-0	A _{IN0} Low Limit	R/W	This register contains the low limit of the A _{IN0} analog input channel.

Table 103. REGISTER 59H, A_{IN1} LOW LIMIT (POWER-ON DEFAULT 00H)

Bit	Name	R/W	Description
7-0	A _{IN1} Low Limit	R/W	This register contains the low limit of the A _{IN1} analog input channel.

Table 104. REGISTER 5AH, A_{IN2} LOW LIMIT (POWER-ON DEFAULT 00H)

Bit	Name	R/W	Description
7-0	A _{IN2} Low Limit	R/W	This register contains the low limit of the A _{IN2} analog input channel.

Table 105. REGISTER 5BH, A_{IN3} LOW LIMIT (POWER-ON DEFAULT 00H)

Bit	Name	R/W	Description
7-0	A _{IN3} Low Limit	R/W	This register contains the low limit of the A _{IN3} analog input channel.

Table 106. REGISTER 5CH, A_{IN4} LOW LIMIT (POWER-ON DEFAULT 00H)

Bit	Name	R/W	Description
7-0	A _{IN4} Low Limit	R/W	This register contains the low limit of the A _{IN4} analog input channel.

Table 107. REGISTER 5DH, A_{IN5} LOW LIMIT (POWER-ON DEFAULT 00H)

Bit	Name	R/W	Description
7-0	A _{IN5} Low Limit	R/W	This register contains the low limit of the A _{IN5} analog input channel.

Table 108. REGISTER 5EH, A_{IN6} LOW LIMIT (POWER-ON DEFAULT 00H)

Bit	Name	R/W	Description
7-0	A _{IN6} Low Limit	R/W	This register contains the low limit of the A _{IN6} analog input channel.

ADM1026

Table 109. REGISTER 5FH, A_{IN7} LOW LIMIT (POWER-ON DEFAULT 00H)

Bit	Name	R/W	Description
7-0	A _{IN7} Low Limit	R/W	This register contains the low limit of the A _{IN7} analog input channel.

Table 110. REGISTER 60H, FAN0 HIGH LIMIT (POWER-ON DEFAULT FFH)

Bit	Name	R/W	Description
7-0	FAN0 High Limit	R/W	This register contains the high limit of the FAN0 tach channel.

Table 111. REGISTER 61H, FAN1 HIGH LIMIT (POWER-ON DEFAULT FFH)

Bit	Name	R/W	Description
7-0	FAN1 High Limit	R/W	This register contains the high limit of the FAN1 tach channel.

Table 112. REGISTER 62H, FAN2 HIGH LIMIT (POWER-ON DEFAULT FFH)

Bit	Name	R/W	Description
7-0	FAN2 High Limit	R/W	This register contains the high limit of the FAN2 tach channel.

Table 113. REGISTER 63H, FAN3 HIGH LIMIT (POWER-ON DEFAULT FFH)

Bit	Name	R/W	Description
7-0	FAN3 High Limit	R/W	This register contains the high limit of the FAN3 tach channel.

Table 114. REGISTER 64H, FAN4 HIGH LIMIT (POWER-ON DEFAULT FFH)

Bit	Name	R/W	Description
7-0	FAN4 High Limit	R/W	This register contains the high limit of the FAN4 tach channel.

Table 115. REGISTER 65H, FAN5 HIGH LIMIT (POWER-ON DEFAULT FFH)

Bit	Name	R/W	Description
7-0	FAN5 High Limit	R/W	This register contains the high limit of the FAN5 tach channel.

Table 116. REGISTER 66H, FAN6 HIGH LIMIT (POWER-ON DEFAULT FFH)

Bit	Name	R/W	Description
7-0	FAN6 High Limit	R/W	This register contains the high limit of the FAN6 tach channel.

Table 117. REGISTER 67H, FAN7 HIGH LIMIT (POWER-ON DEFAULT FFH)

Bit	Name	R/W	Description
7-0	FAN7 High Limit	R/W	This register contains the high limit of the FAN7 tach channel.

Table 118. REGISTER 68H, INT TEMP HIGH LIMIT (POWER-ON DEFAULT, 50H 80°C)

Bit	Name	R/W	Description
7-0	Int Temp High Limit	R/W	This register contains the high limit of the internal temperature channel.

Table 119. REGISTER 69H, INT TEMP HIGH LIMIT (POWER-ON DEFAULT 80H)

Bit	Name	R/W	Description
7-0	Int Temp Low Limit	R/W	This register contains the low limit of the internal temperature channel.

ADM1026

Table 120. REGISTER 6AH, V_{BAT} HIGH LIMIT (POWER-ON DEFAULT FFH)

Bit	Name	R/W	Description
7-0	V _{BAT} High Limit	R/W	This register contains the high limit of the V _{BAT} analog input channel.

Table 121. REGISTER 6BH, V_{BAT} LOW LIMIT (POWER-ON DEFAULT 00H)

Bit	Name	R/W	Description
7-0	V _{BAT} Low Limit	R/W	This register contains the low limit of the V _{BAT} analog input channel.

Table 122. REGISTER 6CH, A_{IN8} HIGH LIMIT (POWER-ON DEFAULT FFH)

Bit	Name	R/W	Description
7-0	A _{IN8} High Limit	R/W	This register contains the high limit of the A _{IN8} analog input channel.

Table 123. REGISTER 6DH, A_{IN8} LOW LIMIT (POWER-ON DEFAULT 00H)

Bit	Name	R/W	Description
7-0	A _{IN8} Low Limit	R/W	This register contains the low limit of the A _{IN8} analog input channel.

Table 124. REGISTER 6EH, EXT1 TEMP OFFSET (POWER-ON DEFAULT 00H)

Bit	Name	R/W	Description
7-0	Ext1 Temp Offset	R/W	This register contains the offset value for the external 1 temperature channel. A twos complement number can be written to this register, which is then added to the measured result before it is stored or compared to limits. In this way, a sort of one-point calibration can be done whereby the whole transfer function of the channel can be moved up or down. From a software point of view, this may be a very simple method to vary the characteristics of the measurement channel if the thermal characteristics change for any reason (for instance from one chassis to another), if the measurement point is moved, if a plug-in card is inserted or removed, and so on.

Table 125. REGISTER 6FH, EXT2 TEMP OFFSET (POWER-ON DEFAULT 00H)

Bit	Name	R/W	Description
7-0	Ext2 Temp Offset	R/W	This register contains the offset value for the external 2 temperature channel. A twos complement number can be written to this register, which is then added to the measured result before it is stored or compared to limits. In this way, a sort of one-point calibration can be done whereby the whole transfer function of the channel can be moved up or down. From a software point of view, this may be a very simple method to vary the characteristics of the measurement channel if the thermal characteristics change for any reason (for instance from one chassis to another), if the measurement point is moved, if a plug-in card is inserted or removed, and so on.

Table 126. ORDERING INFORMATION

Device Order Number	Temperature Range	Package Type	Package Option	Shipping [†]
ADM1026JSTZ-REEL	0°C to +100°C	48-Lead LQFP (Pb-Free)	ST-48	2,000 Tape & Reel

[†]For information on tape and reel specifications, including part orientation and tape sizes, please refer to our Tape and Reel Packaging Specifications Brochure, BRD8011/D.

*The "Z" suffix indicates Pb-Free part.

MECHANICAL CASE OUTLINE PACKAGE DIMENSIONS

ON Semiconductor®

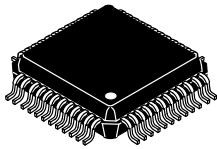

48 LEAD LQFP, 7x7, 0.5P
CASE 932AA-01
ISSUE A

DATE 13 OCT 2008

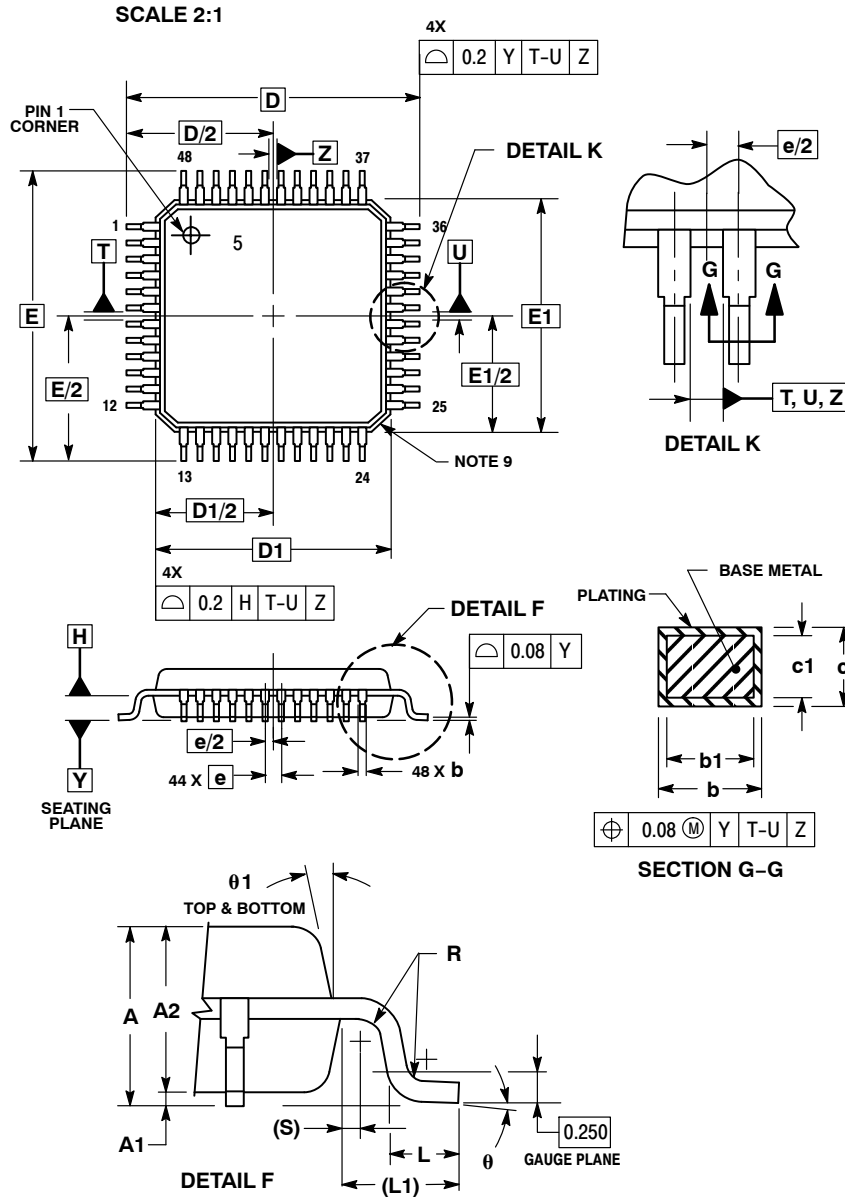

NOTES:

1. DIMENSIONS ARE IN MILLIMETERS.
2. INTERPRET DIMENSIONS AND TOLERANCES PER ASME Y14.5M, 1994.
3. DATUM PLANE H IS LOCATED AT BOTTOM OF LEAD AND IS COINCIDENT WITH THE LEAD WHERE THE LEAD EXITS THE PLASTIC BODY AT THE BOTTOM OF THE PARTING LINE.
4. DATUMS T, U, AND Z TO BE DETERMINED AT DATUM PLANE H.
5. DIMENSIONS D AND E TO BE DETERMINED AT SEATING PLANE Y.
6. DIMENSIONS D1 AND E1 DO NOT INCLUDE MOLD PROTRUSION. ALLOWABLE PROTRUSION IS 0.250 PER SIDE. DIMENSIONS D1 AND E1 DO INCLUDE MOLD MISMATCH AND ARE DETERMINED AT DATUM PLANE H.
7. DIMENSION b DOES NOT INCLUDE DAMBAR PROTRUSION. DAMBAR PROTRUSION SHALL NOT CAUSE THE b DIMENSION TO EXCEED 0.350.
8. MINIMUM SOLDER PLATE THICKNESS SHALL BE 0.0076.
9. EXACT SHAPE OF EACH CORNER IS OPTIONAL.

MILLIMETERS		
DIM	MIN	MAX
A	1.4	1.6
A1	0.05	0.15
A2	1.35	1.45
b	0.17	0.27
b1	0.17	0.23
c	0.09	0.20
c1	0.09	0.16
D	9.0 BSC	
D1	7.0 BSC	
e	0.5 BSC	
E	9.0 BSC	
E1	7.0 BSC	
L	0.5	0.7
L1	1.0 REF	
R	0.15	0.25
S	0.2 REF	
θ	1°	5°
θ1	12 REF	

GENERIC MARKING DIAGRAM*

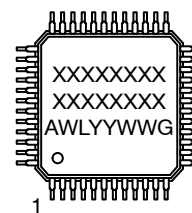

- XXXXX = Specific Device Code
- A = Assembly Location
- WL = Wafer Lot
- YY = Year
- WW = Work Week
- G = Pb-Free Package

*This information is generic. Please refer to device data sheet for actual part marking.

DOCUMENT NUMBER:	98AON13058D	Electronic versions are uncontrolled except when accessed directly from the Document Repository. Printed versions are uncontrolled except when stamped "CONTROLLED COPY" in red.
DESCRIPTION:	48 LEAD LQFP 7X7X1.4, 0.5 PITCH	PAGE 1 OF 1

ON Semiconductor and are trademarks of Semiconductor Components Industries, LLC dba ON Semiconductor or its subsidiaries in the United States and/or other countries. ON Semiconductor reserves the right to make changes without further notice to any products herein. ON Semiconductor makes no warranty, representation or guarantee regarding the suitability of its products for any particular purpose, nor does ON Semiconductor assume any liability arising out of the application or use of any product or circuit, and specifically disclaims any and all liability, including without limitation special, consequential or incidental damages. ON Semiconductor does not convey any license under its patent rights nor the rights of others.

onsemi, **Onsemi**, and other names, marks, and brands are registered and/or common law trademarks of Semiconductor Components Industries, LLC dba "**onsemi**" or its affiliates and/or subsidiaries in the United States and/or other countries. **onsemi** owns the rights to a number of patents, trademarks, copyrights, trade secrets, and other intellectual property. A listing of **onsemi**'s product/patent coverage may be accessed at www.onsemi.com/site/pdf/Patent-Marking.pdf. **onsemi** reserves the right to make changes at any time to any products or information herein, without notice. The information herein is provided "as-is" and **onsemi** makes no warranty, representation or guarantee regarding the accuracy of the information, product features, availability, functionality, or suitability of its products for any particular purpose, nor does **onsemi** assume any liability arising out of the application or use of any product or circuit, and specifically disclaims any and all liability, including without limitation special, consequential or incidental damages. Buyer is responsible for its products and applications using **onsemi** products, including compliance with all laws, regulations and safety requirements or standards, regardless of any support or applications information provided by **onsemi**. "Typical" parameters which may be provided in **onsemi** data sheets and/or specifications can and do vary in different applications and actual performance may vary over time. All operating parameters, including "Typicals" must be validated for each customer application by customer's technical experts. **onsemi** does not convey any license under any of its intellectual property rights nor the rights of others. **onsemi** products are not designed, intended, or authorized for use as a critical component in life support systems or any FDA Class 3 medical devices or medical devices with a same or similar classification in a foreign jurisdiction or any devices intended for implantation in the human body. Should Buyer purchase or use **onsemi** products for any such unintended or unauthorized application, Buyer shall indemnify and hold **onsemi** and its officers, employees, subsidiaries, affiliates, and distributors harmless against all claims, costs, damages, and expenses, and reasonable attorney fees arising out of, directly or indirectly, any claim of personal injury or death associated with such unintended or unauthorized use, even if such claim alleges that **onsemi** was negligent regarding the design or manufacture of the part. **onsemi** is an Equal Opportunity/Affirmative Action Employer. This literature is subject to all applicable copyright laws and is not for resale in any manner.

PUBLICATION ORDERING INFORMATION

LITERATURE FULFILLMENT:

Email Requests to: orderlit@onsemi.com

onsemi Website: www.onsemi.com

TECHNICAL SUPPORT

North American Technical Support:

Voice Mail: 1 800-282-9855 Toll Free USA/Canada

Phone: 011 421 33 790 2910

Europe, Middle East and Africa Technical Support:

Phone: 00421 33 790 2910

For additional information, please contact your local Sales Representative

X-ON Electronics

Largest Supplier of Electrical and Electronic Components

Click to view similar products for [Board Mount Temperature Sensors](#) category:

Click to view products by [ON Semiconductor](#) manufacturer:

Other Similar products are found below :

[5962-8757102XA](#) [66F115](#) [EMC1063-1-ACZL-TR](#) [NCT218FCT2G](#) [O53GAB175A-160Y](#) [3610085020002](#) [389049M9527](#) [MIKROE-912](#)
[ADM1023ARQZ-REEL](#) [ADM1032ARMZ-1RL](#) [AT30TS74-U1FMBB-T](#) [AT30TS74-U1FMAB-T](#) [AT30TS74-U1FMCB-T](#) [AT30TS74-](#)
[U1FMDB-T](#) [ADT7483AARQZ-RL](#) [ADT7481ARMZ-REEL](#) [ADT7463ARQZ-REEL](#) [MCP98243T-BE/MC](#) [66L080-0226](#) [5962-8757103XA](#)
[S-58LM20A-I4T1U](#) [EMC2302-2-AIZL-TR](#) [NCT375MNR2G](#) [LM84CIMQA](#) [CAT34TS00VP2GT4A](#) [NCT80DBR2G](#) [SEN-16304](#) [GX21M15](#)
[GX122](#) [NST175H-QSPR](#) [TC6501P065VCTTR](#) [AT-1U](#) [MCP9700AT-E/LT](#) [MCP9701-E/TO](#) [MCP9803-M/MS](#) [MCP9701A-E/TO](#)
[LM57FEPWQ1](#) [LM57FPW](#) [LM57FSPWQ1](#) [60-41123102-0150.0010](#) [60-43123102-0150.0010](#) [60-53123102-0150.0010](#) [MLX90615SSG-](#)
[DAA-000-TU](#) [TMP303CDRLR](#) [TC6501P055VCTTR](#) [TC6503P005VCTTR](#) [ADT7311WTRZ-RL](#) [ADT7473ARQZ-REEL](#) [LM335AM](#)
[LM335AM/NOPB](#)