

# ON Semiconductor

## Is Now

The logo for onsemi, featuring the word "onsemi" in a dark teal, lowercase, sans-serif font. The letter "i" is stylized with a white dot and a teal vertical bar. A small orange triangle is positioned above the top right of the "i". A trademark symbol (TM) is located to the right of the logo.

To learn more about onsemi™, please visit our website at  
[www.onsemi.com](http://www.onsemi.com)

---

**onsemi** and **onsemi** and other names, marks, and brands are registered and/or common law trademarks of Semiconductor Components Industries, LLC dba "**onsemi**" or its affiliates and/or subsidiaries in the United States and/or other countries. **onsemi** owns the rights to a number of patents, trademarks, copyrights, trade secrets, and other intellectual property. A listing of **onsemi** product/patent coverage may be accessed at [www.onsemi.com/site/pdf/Patent-Marking.pdf](http://www.onsemi.com/site/pdf/Patent-Marking.pdf). **onsemi** reserves the right to make changes at any time to any products or information herein, without notice. The information herein is provided "as-is" and **onsemi** makes no warranty, representation or guarantee regarding the accuracy of the information, product features, availability, functionality, or suitability of its products for any particular purpose, nor does **onsemi** assume any liability arising out of the application or use of any product or circuit, and specifically disclaims any and all liability, including without limitation special, consequential or incidental damages. Buyer is responsible for its products and applications using **onsemi** products, including compliance with all laws, regulations and safety requirements or standards, regardless of any support or applications information provided by **onsemi**. "Typical" parameters which may be provided in **onsemi** data sheets and/or specifications can and do vary in different applications and actual performance may vary over time. All operating parameters, including "Typicals" must be validated for each customer application by customer's technical experts. **onsemi** does not convey any license under any of its intellectual property rights nor the rights of others. **onsemi** products are not designed, intended, or authorized for use as a critical component in life support systems or any FDA Class 3 medical devices or medical devices with a same or similar classification in a foreign jurisdiction or any devices intended for implantation in the human body. Should Buyer purchase or use **onsemi** products for any such unintended or unauthorized application, Buyer shall indemnify and hold **onsemi** and its officers, employees, subsidiaries, affiliates, and distributors harmless against all claims, costs, damages, and expenses, and reasonable attorney fees arising out of, directly or indirectly, any claim of personal injury or death associated with such unintended or unauthorized use, even if such claim alleges that **onsemi** was negligent regarding the design or manufacture of the part. **onsemi** is an Equal Opportunity/Affirmative Action Employer. This literature is subject to all applicable copyright laws and is not for resale in any manner. Other names and brands may be claimed as the property of others.

# AMIS-30660

## High Speed CAN Transceiver

### Description

The AMIS-30660 CAN transceiver is the interface between a controller area network (CAN) protocol controller and the physical bus and may be used in both 12 V and 24 V systems. The transceiver provides differential transmit capability to the bus and differential receive capability to the CAN controller.

Due to the wide common-mode voltage range of the receiver inputs, the AMIS-30660 is able to reach outstanding levels of electromagnetic susceptibility (EMS). Similarly, extremely low electromagnetic emission (EME) is achieved by the excellent matching of the output signals.

### Features

- Fully Compatible with the ISO 11898-2 Standard
- Certified “Authentication on CAN Transceiver Conformance (d1.1)”
- High Speed (up to 1 Mbit/s)
- Ideally Suited for 12 V and 24 V Industrial and Automotive Applications
- Low EME Common-Mode Choke is No Longer Required
- Differential Receiver with Wide Common-Mode Range ( $\pm 35$  V) for High EMS
- No Disturbance of the Bus Lines with an Unpowered Node
- Transmit Data (TxD) Dominant Time-out Function
- Thermal Protection
- Bus Pins Protected Against Transients in an Automotive Environment
- Silent Mode in which the Transmitter is Disabled
- Short Circuit Proof to Supply Voltage and Ground
- Logic Level Inputs Compatible with 3.3 V Devices
- These are Pb-Free Devices\*



ON Semiconductor®

<http://onsemi.com>

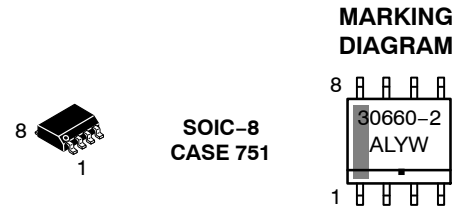

30660-2 = Specific Device Code  
A = Assembly Location  
L = Wafer Lot  
Y = Year  
W = Work Week  
▪ = Pb-Free Package

### PIN ASSIGNMENT

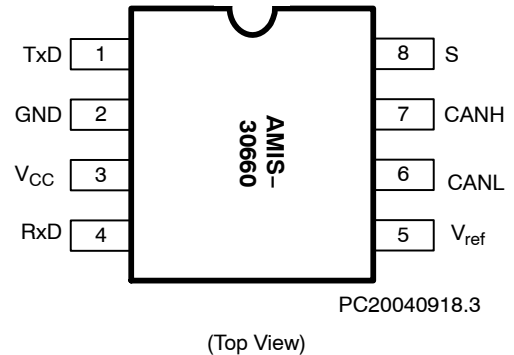

### ORDERING INFORMATION

See detailed ordering and shipping information in the package dimensions section on page 9 of this data sheet.

\*For additional information on our Pb-Free strategy and soldering details, please download the ON Semiconductor Soldering and Mounting Techniques Reference Manual, SOLDERRM/D.

Table 1. TECHNICAL CHARACTERISTICS

| Symbol                 | Parameter   | Conditions   | Min  | Max | Unit |
|------------------------|---|--|------|-----|------|
| $V_{CANH}$             | DC Voltage at Pin CANH                            | $0 < V_{CC} < 5.25 \text{ V}$ ; No Time Limit                  | -45  | +45 | V    |
| $V_{CANL}$             | DC Voltage at Pin CANL                            | $0 < V_{CC} < 5.25 \text{ V}$ ; No Time Limit                  | -45  | +45 | V    |
| $V_{o(dif)(bus\_dom)}$ | Differential Bus Output Voltage in Dominant State | $42.5 \Omega < R_{LT} < 60 \Omega$                             | 1.5  | 3   | V    |
| $t_{pd(rec-dom)}$      | Propagation Delay TxD to RxD                      | See Figure 6   | 70   | 245 | ns   |
| $t_{pd(dom-rec)}$      | Propagation Delay TxD to RxD                      | See Figure 6   | 100  | 245 | ns   |
| $C_{M-range}$          | Input Common-Mode Range for Comparator            | Guaranteed Differential Receiver Threshold and Leakage Current | -35  | +35 | V    |
| $V_{CM-peak}$          | Common-Mode Peak                                  | See Figures 7 and 8 (Note 1)                                   | -500 | 500 | mV   |
| $V_{CM-step}$          | Common-Mode Step                                  | See Figures 7 and 8 (Note 1)                                   | -150 | 150 | mV   |

1. The parameters  $V_{CM-peak}$  and  $V_{CM-step}$  guarantee low electromagnetic emission.

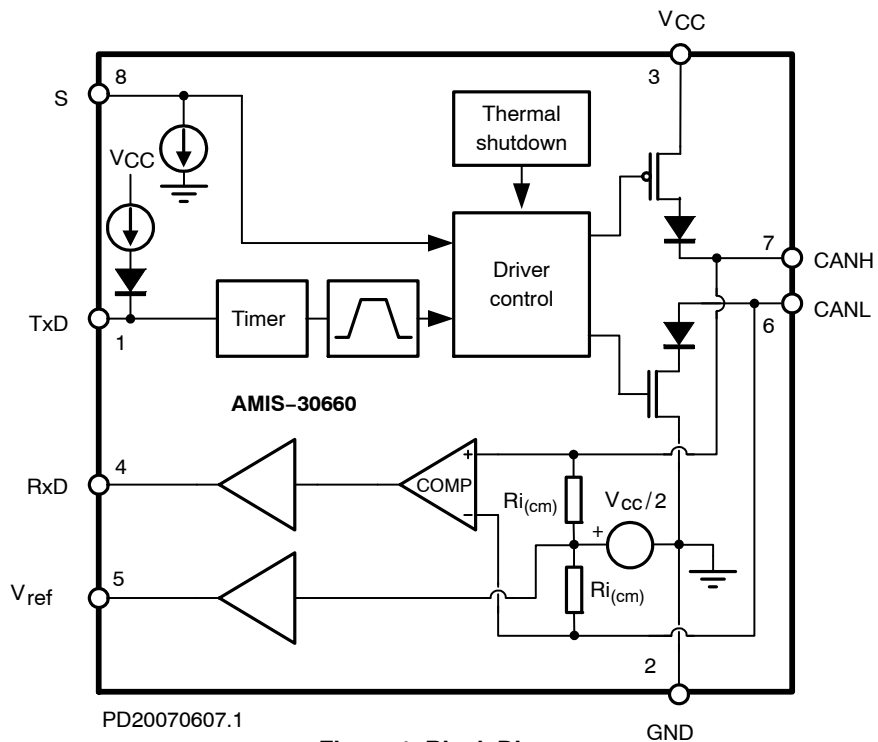

Figure 1. Block Diagram

Table 2. PIN LIST AND DESCRIPTIONS

| Pin | Name             | Description  |
|-----|------------------|--|
| 1   | TxD              | Transmit data input; low input → dominant driver; internal pull-up current |
| 2   | GND              | Ground   |
| 3   | V <sub>CC</sub>  | Supply voltage   |
| 4   | RxD              | Receive data output; dominant transmitter → low output                     |
| 5   | V <sub>REF</sub> | Reference voltage output   |
| 6   | CANL             | Low-level CAN bus line (low in dominant mode)                              |
| 7   | CANH             | High-level CAN bus line (high in dominant mode)                            |
| 8   | S                | Silent mode control input; internal pull-down current                      |

**Table 3. ABSOLUTE MAXIMUM RATINGS**

| Symbol                  | Parameter                                   | Conditions                                     | Min        | Max                   | Unit    |
|-------------------------|---|--|------------|-----------------------|---------|
| V <sub>CC</sub>         | Supply Voltage                              |  | -0.3       | +7                    | V       |
| V <sub>CANH</sub>       | DC Voltage at Pin CANH                      | 0 < V <sub>CC</sub> < 5.25 V;<br>No Time Limit | -45        | +45                   | V       |
| V <sub>CANL</sub>       | DC Voltage at Pin CANL                      | 0 < V <sub>CC</sub> < 5.25 V;<br>No Time Limit | -45        | +45                   | V       |
| V <sub>TxD</sub>        | DC Voltage at Pin TxD                       |  | -0.3       | V <sub>CC</sub> + 0.3 | V       |
| V <sub>RxD</sub>        | DC Voltage at Pin RxD                       |  | -0.3       | V <sub>CC</sub> + 0.3 | V       |
| V <sub>S</sub>          | DC Voltage at Pin S                         |  | -0.3       | V <sub>CC</sub> + 0.3 | V       |
| V <sub>ref</sub>        | DC Voltage at Pin V <sub>REF</sub>          |  | -0.3       | V <sub>CC</sub> + 0.3 | V       |
| V <sub>tran(CANH)</sub> | Transient Voltage at Pin CANH               | (Note 2)                                       | -150       | +150                  | V       |
| V <sub>tran(CANL)</sub> | Transient Voltage at Pin CANL               | (Note 2)                                       | -150       | +150                  | V       |
| V <sub>esd</sub>        | Electrostatic Discharge Voltage at All Pins | (Note 3)<br>(Note 5)                           | -4<br>-500 | +4<br>+500            | kV<br>V |
| Latchup                 | Static Latchup at All Pins                  | (Note 4)                                       |            | 100                   | mA      |
| T <sub>stg</sub>        | Storage Temperature                         |  | -55        | +155                  | °C      |
| T <sub>amb</sub>        | Ambient Temperature                         |  | -40        | +125                  | °C      |
| T <sub>Junc</sub>       | Maximum Junction Temperature                |  | -40        | +150                  | °C      |

Stresses exceeding Maximum Ratings may damage the device. Maximum Ratings are stress ratings only. Functional operation above the Recommended Operating Conditions is not implied. Extended exposure to stresses above the Recommended Operating Conditions may affect device reliability.

2. Applied transient waveforms in accordance with ISO 7637 part 3, test pulses 1, 2, 3a, and 3b (see Figure 4).
3. Standardized human body model ESD pulses in accordance to MIL883 method 3015.7.
4. Static latch-up immunity: static latch-up protection level when tested according to EIA/JESD78.
5. Standardized charged device model ESD pulses when tested according to EOS/ESD DS5.3-1993.

**Table 4. THERMAL CHARACTERISTICS**

| Symbol                | Parameter   | Conditions  | Value | Unit |
|-----------------------|---|-------------|-------|------|
| R <sub>th(vj-a)</sub> | Thermal Resistance from Junction-to-Ambient in SOIC-8 Package | In Free Air | 150   | K/W  |
| R <sub>th(vj-s)</sub> | Thermal resistance from Junction-to-Substrate of Bare Die     | In Free Air | 45    | K/W  |

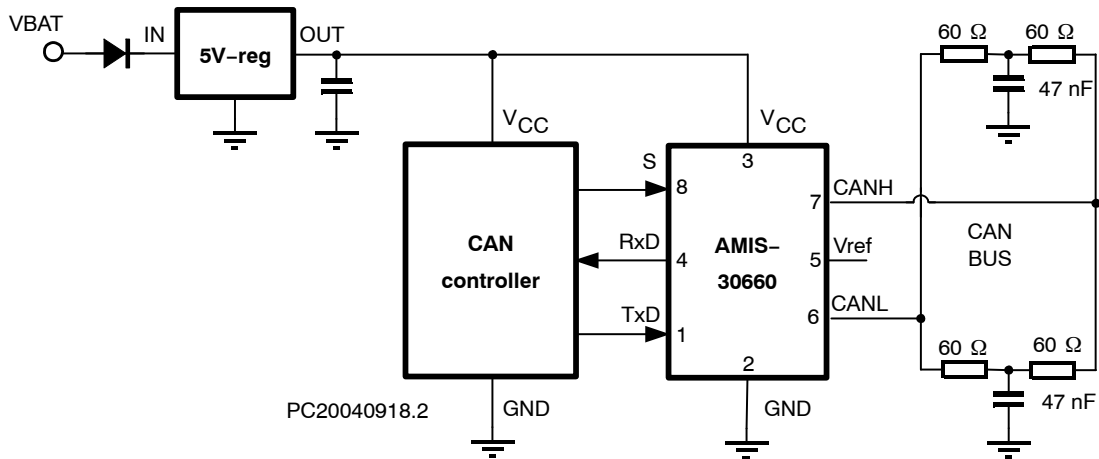

**Figure 2. Application Diagram**

FUNCTIONAL DESCRIPTION

**Operating Modes**

The behavior of AMIS-30660 under various conditions is illustrated in Table 5 below. In case the device is powered, one of two operating modes can be selected through Pin S.

**Table 5. FUNCTIONAL TABLE OF AMIS-30660** (X = DON'T CARE)

| VCC                                     | Pin TxD         | Pin S           | Pin CANH                             | Pin CANL                             | Bus State | Pin RxD |
|---|-----------------|-----------------|--------------------------------------|--------------------------------------|-----------|---------|
| 4.75 V to 5.25 V                        | 0               | 0 (or Floating) | High                                 | Low                                  | Dominant  | 0       |
| 4.75 V to 5.25 V                        | X               | 1               | $V_{CC} / 2$                         | $V_{CC} / 2$                         | Recessive | 1       |
| 4.75 V to 5.25 V                        | 1 (or Floating) | X               | $V_{CC} / 2$                         | $V_{CC} / 2$                         | Recessive | 1       |
| $V_{CC} < \text{PORL}$ (Unpowered)      | X               | X               | $0 \text{ V} < \text{CANH} < V_{CC}$ | $0 \text{ V} < \text{CANL} < V_{CC}$ | Recessive | 1       |
| $\text{PORL} < V_{CC} < 4.75 \text{ V}$ | $> 2 \text{ V}$ | X               | $0 \text{ V} < \text{CANH} < V_{CC}$ | $0 \text{ V} < \text{CANL} < V_{CC}$ | Recessive | 1       |

**High-Speed Mode**

If Pin S is pulled low (or left floating), the transceiver is in its high-speed mode and is able to communicate via the bus lines. The signals are transmitted and received to the CAN controller via the Pins TxD and RxD. The slopes on the bus line outputs are optimized to give extremely low electromagnetic emissions.

**Silent Mode**

In silent mode, the transmitter is disabled. All other IC functions continue to operate. The silent mode is selected by connecting Pin S to  $V_{CC}$  and can be used to prevent network communication from being blocked, due to a CAN controller which is out of control.

**Overtemperature Detection**

A thermal protection circuit protects the IC from damage by switching off the transmitter if the junction temperature exceeds a value of approximately 160°C. Because the transmitter dissipates most of the power, the power dissipation and temperature of the IC is reduced. All other IC functions continue to operate. The transmitter off-state resets when Pin TxD goes high. The thermal protection

circuit is particularly necessary when a bus line short-circuits.

**TxD Dominant Time-out Function**

A TxD dominant time-out timer circuit prevents the bus lines from being driven to a permanent dominant state (blocking all network communication) if Pin TxD is forced permanently low by a hardware and/or software application failure. The timer is triggered by a negative edge on pin TxD. If the duration of the low-level on Pin TxD exceeds the internal timer value  $t_{\text{dom}}$ , the transmitter is disabled, driving the bus into a recessive state. The timer is reset by a positive edge on Pin TxD.

**Fail-Safe Features**

A current-limiting circuit protects the transmitter output stage from damage caused by an accidental short-circuit to either positive or negative supply voltage, although power dissipation increases during this fault condition.

The Pins CANH and CANL are protected from automotive electrical transients (according to “ISO 7637”; see Figure 3). Pin TxD is pulled high internally should the input become disconnected.

ELECTRICAL CHARACTERISTICS

Definitions

All voltages are referenced to GND (Pin 2). Positive currents flow into the IC. Sinking current means the current

is flowing into the pin; sourcing current means the current is flowing out of the pin.

Table 6. DC AND TIMING CHARACTERISTICS

(V<sub>CC</sub> = 4.75 V to 5.25 V; T<sub>junc</sub> = -40°C to +150°C; R<sub>LT</sub> = 60 Ω unless specified otherwise.)

| Symbol  | Parameter  | Conditions  | Min                       | Typ                       | Max                       | Unit |
|---|--|---|---------------------------|---------------------------|---------------------------|------|
| <b>SUPPLY (Pin V<sub>CC</sub>)</b>                    |  |   |                           |                           |                           |      |
| I <sub>CC</sub>                                       | Supply Current   | Dominant; V <sub>TxD</sub> = 0 V<br>Recessive; V <sub>TxD</sub> = V <sub>CC</sub> | 25<br>2                   | 45<br>4                   | 65<br>8                   | mA   |
| I <sub>CCS</sub>                                      | Supply Current in silent mode  | V <sub>S</sub> = V <sub>CC</sub>  | 2                         | 4                         | 8                         | mA   |
| <b>TRANSMITTER DATA INPUT (Pin TxD)</b>               |  |   |                           |                           |                           |      |
| V <sub>IH</sub>                                       | High-level input voltage   | Output recessive  | 2.0                       | -                         | V <sub>CC</sub> +0.3      | V    |
| V <sub>IL</sub>                                       | Low-level input voltage  | Output dominant   | -0.3                      | -                         | +0.8                      | V    |
| I <sub>IH</sub>                                       | High-level input current   | V <sub>TxD</sub> = V <sub>CC</sub>  | -1                        | 0                         | +1                        | μA   |
| I <sub>IL</sub>                                       | Low-level input current  | V <sub>TxD</sub> = 0 V  | -75                       | -200                      | -350                      | μA   |
| C <sub>i</sub>  | Input capacitance  | Not tested  | -                         | 5                         | 10                        | pF   |
| <b>MODE SELECT (Pin S)</b>                            |  |   |                           |                           |                           |      |
| V <sub>IH</sub>                                       | High-level input voltage   | Silent mode   | 2.0                       | -                         | V <sub>CC</sub> +0.3      | V    |
| V <sub>IL</sub>                                       | Low-level input voltage  | High-speed mode   | -0.3                      | -                         | +0.8                      | V    |
| I <sub>IH</sub>                                       | High-level input current   | V <sub>S</sub> = 2 V  | 20                        | 30                        | 50                        | μA   |
| I <sub>IL</sub>                                       | Low-level input current  | V <sub>S</sub> = 0.8 V  | 15                        | 30                        | 45                        | μA   |
| <b>RECEIVER DATA OUTPUT (Pin RxD)</b>                 |  |   |                           |                           |                           |      |
| V <sub>OH</sub>                                       | High-level output voltage  | I <sub>RxD</sub> = - 10 mA  | 0.6 x<br>V <sub>CC</sub>  | 0.75 x<br>V <sub>CC</sub> |                           | V    |
| V <sub>OL</sub>                                       | Low-level output voltage   | I <sub>RxD</sub> = 6 mA   |                           | 0.25                      | 0.45                      | V    |
| <b>REFERENCE VOLTAGE OUTPUT (Pin V<sub>ref</sub>)</b> |  |   |                           |                           |                           |      |
| V <sub>REF</sub>                                      | Reference output voltage   | -50 μA < I <sub>VREF</sub> < +50 μA   | 0.45 x<br>V <sub>CC</sub> | 0.50 x<br>V <sub>CC</sub> | 0.55 x<br>V <sub>CC</sub> | V    |
| V <sub>REF_CM</sub>                                   | Reference output voltage for full common mode range                      | -35 V < V <sub>CANH</sub> < +35V;<br>-35 V < V <sub>CANL</sub> < +35V             | 0.40 x<br>V <sub>CC</sub> | 0.50 x<br>V <sub>CC</sub> | 0.60 x<br>V <sub>CC</sub> | V    |
| <b>BUS LINES (Pins CANH and CANL)</b>                 |  |   |                           |                           |                           |      |
| V <sub>o(reces)</sub> (CANH)                          | Recessive bus voltage at pin CANH  | V <sub>TxD</sub> = V <sub>CC</sub> ; no load                                      | 2.0                       | 2.5                       | 3.0                       | V    |
| V <sub>o(reces)</sub> (CANL)                          | Recessive bus voltage at pin CANL  | V <sub>TxD</sub> = V <sub>CC</sub> ; no load                                      | 2.0                       | 2.5                       | 3.0                       | V    |
| I <sub>o(reces)</sub> (CANH)                          | Recessive output current at pin CANH                                     | -35 V < V <sub>CANH</sub> < +35 V;<br>0 V < V <sub>CC</sub> < 5.25 V              | -2.5                      | -                         | +2.5                      | mA   |
| I <sub>o(reces)</sub> (CANL)                          | Recessive output current at pin CANL                                     | -35 V < V <sub>CANL</sub> < +35 V;<br>0V < V <sub>CC</sub> < 5.25 V               | -2.5                      | -                         | +2.5                      | mA   |
| V <sub>o(dom)</sub> (CANH)                            | Dominant output voltage at pin CANH                                      | V <sub>TxD</sub> = 0 V  | 3.0                       | 3.6                       | 4.25                      | V    |
| V <sub>o(dom)</sub> (CANL)                            | Dominant output voltage at pin CANL                                      | V <sub>TxD</sub> = 0 V  | 0.5                       | 1.4                       | 1.75                      | V    |
| V <sub>o(dif)</sub> (bus)                             | Differential bus output voltage (V <sub>CANH</sub> - V <sub>CANL</sub> ) | V <sub>TxD</sub> = 0 V; dominant;<br>42.5 Ω < R <sub>LT</sub> < 60 Ω              | 1.5                       | 2.25                      | 3.0                       | V    |
|   |  | V <sub>TxD</sub> = V <sub>CC</sub> ; recessive;<br>No load                        | -120                      | 0                         | +50                       | mV   |
| I <sub>o(sc)</sub> (CANH)                             | Short circuit output current at pin CANH                                 | V <sub>CANH</sub> = 0 V; V <sub>TxD</sub> = 0 V                                   | -45                       | -70                       | -95                       | mA   |
| I <sub>o(sc)</sub> (CANL)                             | Short circuit output current at pin CANL                                 | V <sub>CANL</sub> = 36V; V <sub>TxD</sub> = 0V                                    | 45                        | 70                        | 120                       | mA   |

**Table 6. DC AND TIMING CHARACTERISTICS**

( $V_{CC} = 4.75\text{ V to }5.25\text{ V}$ ;  $T_{junc} = -40^{\circ}\text{C to }+150^{\circ}\text{C}$ ;  $R_{LT} = 60\ \Omega$  unless specified otherwise.)

| Symbol  | Parameter  | Conditions   | Min  | Typ  | Max  | Unit               |
|---|--|--|------|------|------|--------------------|
| <b>BUS LINES (Pins CANH and CANL)</b>               |  |  |      |      |      |                    |
| $V_{i(dif)}(th)$                                    | Differential receiver threshold voltage  | $-5\text{ V} < V_{CANL} < +10\text{ V}$ ;<br>$-5\text{ V} < V_{CANH} < +10\text{ V}$ ;<br>See Figure 4   | 0.5  | 0.7  | 0.9  | V                  |
| $V_{ihcm(dif)}(th)$                                 | Differential receiver threshold voltage for high common-mode                           | $-35\text{ V} < V_{CANL} < +35\text{ V}$ ;<br>$-35\text{ V} < V_{CANH} < +35\text{ V}$ ;<br>See Figure 4 | 0.25 | 0.7  | 1.05 | V                  |
| $V_{i(dif)}(hys)$                                   | Differential receiver input voltage hysteresis   | $-5\text{ V} < V_{CANL} < +10\text{ V}$ ;<br>$-5\text{ V} < V_{CANH} < +10\text{ V}$ ;<br>See Figure 4   | 50   | 70   | 100  | mV                 |
| $R_{i(cm)}(CANH)$                                   | Common-mode input resistance at pin CANH   |  | 15   | 25   | 37   | K $\Omega$         |
| $R_{i(cm)}(CANL)$                                   | Common-mode input resistance at pin CANL   |  | 15   | 25   | 37   | K $\Omega$         |
| $R_{i(cm)}(m)$                                      | Matching between pin CANH and pin CANL common-mode input resistance                    | $V_{CANH} = V_{CANL}$  | -3   | 0    | +3   | %                  |
| $R_{i(dif)}$  | Differential input resistance  |  | 25   | 50   | 75   | K $\Omega$         |
| $C_{i(CANH)}$                                       | Input capacitance at pin CANH  | $V_{TxD} = V_{CC}$ ; not tested  |      | 7.5  | 20   | pF                 |
| $C_{i(CANL)}$                                       | Input capacitance at pin CANL  | $V_{TxD} = V_{CC}$ ; not tested  |      | 7.5  | 20   | pF                 |
| $C_{i(dif)}$  | Differential input capacitance   | $V_{TxD} = V_{CC}$ ; not tested  |      | 3.75 | 10   | pF                 |
| $I_{LI}(CANH)$                                      | Input leakage current at pin CANH  | $V_{CC} = 0\text{ V}$ ; $V_{CANH} = 5\text{ V}$  | 10   | 170  | 250  | $\mu\text{A}$      |
| $I_{LI}(CANL)$                                      | Input leakage current at pin CANL  | $V_{CC} = 0\text{ V}$ ; $V_{CANL} = 5\text{ V}$  | 10   | 170  | 250  | $\mu\text{A}$      |
| $V_{CM-peak}$                                       | Common-mode peak during transition from dom $\rightarrow$ rec or rec $\rightarrow$ dom | See Figures 7 and 8  | -500 |      | 500  | mV                 |
| $V_{CM-step}$                                       | Difference in common-mode between dominant and recessive state                         | See Figures 7 and 8  |      | -150 | 150  | mV                 |
| <b>POWER-ON-RESET (POR)</b>                         |  |  |      |      |      |                    |
| PORL  | POR level  | CANH, CANL, $V_{ref}$ in tri-state below POR level   | 2.2  | 3.5  | 4.5  | V                  |
| <b>THERMAL SHUTDOWN</b>                             |  |  |      |      |      |                    |
| $T_{j(sd)}$   | Shutdown junction temperature  |  | 150  | 160  | 180  | $^{\circ}\text{C}$ |
| <b>TIMING CHARACTERISTICS (see Figures 5 and 6)</b> |  |  |      |      |      |                    |
| $t_d(TxD-BUSon)$                                    | Delay TxD to bus active  | $V_s = 0\text{ V}$   | 40   | 85   | 130  | ns                 |
| $t_d(TxD-BUSoff)$                                   | Delay TxD to bus inactive  | $V_s = 0\text{ V}$   | 30   | 60   | 105  | ns                 |
| $t_d(BUSon-RxD)$                                    | Delay bus active to RxD  | $V_s = 0\text{ V}$   | 25   | 55   | 105  | ns                 |
| $t_d(BUSoff-RxD)$                                   | Delay bus inactive to RxD  | $V_s = 0\text{ V}$   | 65   | 100  | 135  | ns                 |
| $t_{pd}(rec-dom)$                                   | Propagation delay TxD to RxD from recessive to dominant                                | $V_s = 0\text{ V}$   | 70   |      | 245  | ns                 |
| $t_d(dom-rec)$                                      | Propagation delay TxD to RxD from dominant to recessive                                | $V_s = 0\text{ V}$   | 100  |      | 245  | ns                 |
| $t_{dom}(TxD)$                                      | TxD dominant time for time out   | $V_{TxD} = 0\text{ V}$   | 250  | 450  | 750  | $\mu\text{s}$      |

# AMIS-30660

## MEASUREMENT SEUPS AND DEFINITIONS

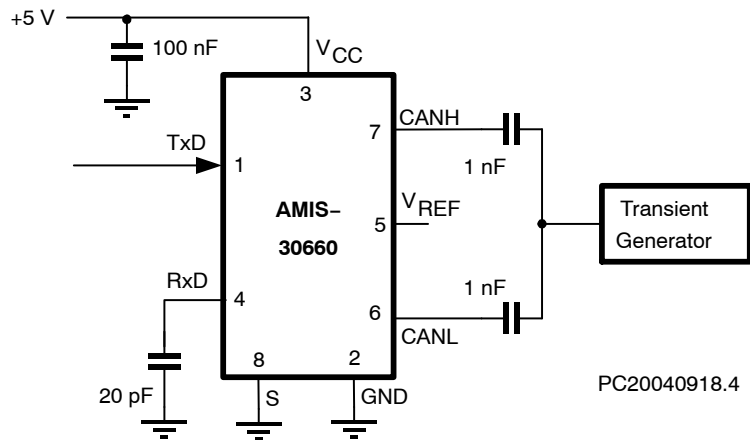

Figure 3. Test Circuit for Automotive Transients

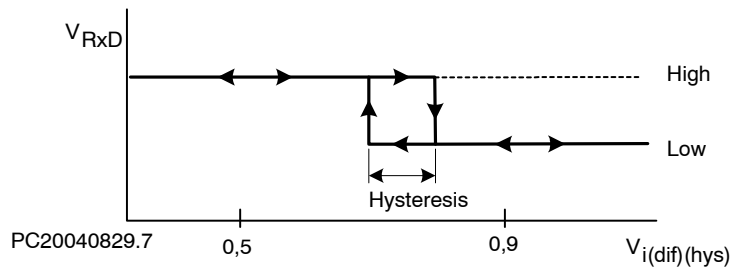

Figure 4. Hysteresis of the Receiver

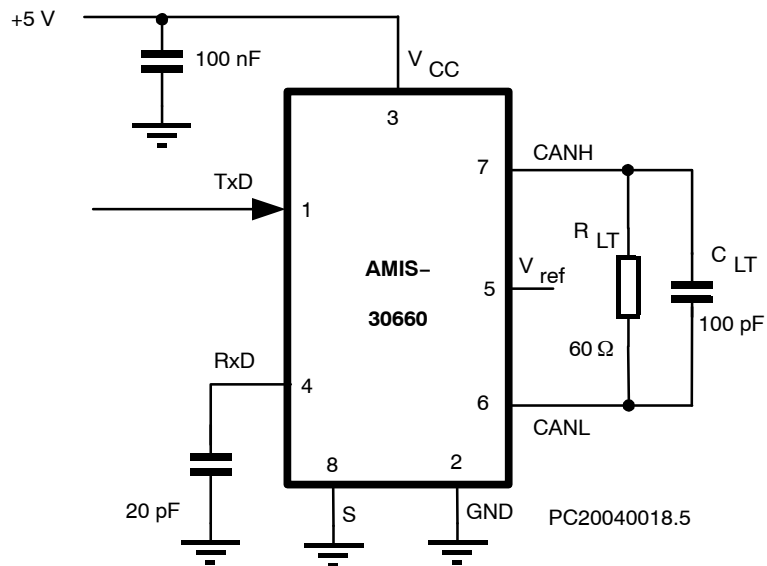
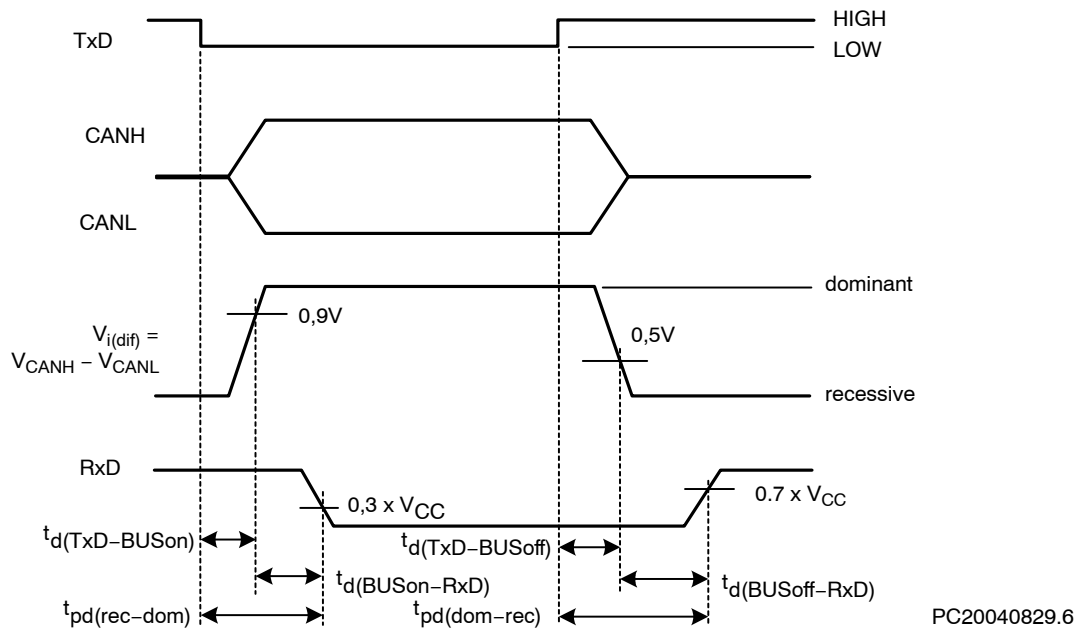

Figure 5. Test Circuit for Timing Characteristics



# AMIS-30660



**Figure 6. Timing Diagram for AC Characteristics**

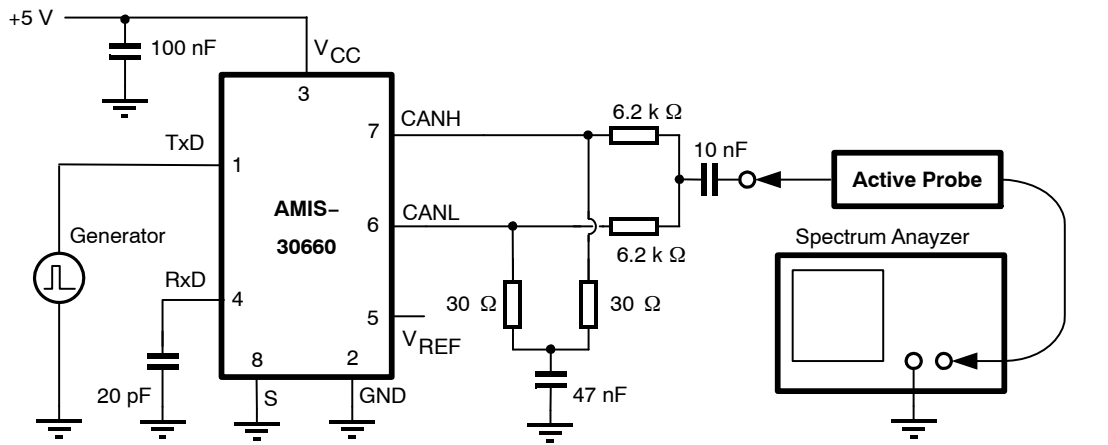

**Figure 7. Basic Test Set-up for Electromagnetic Measurement**

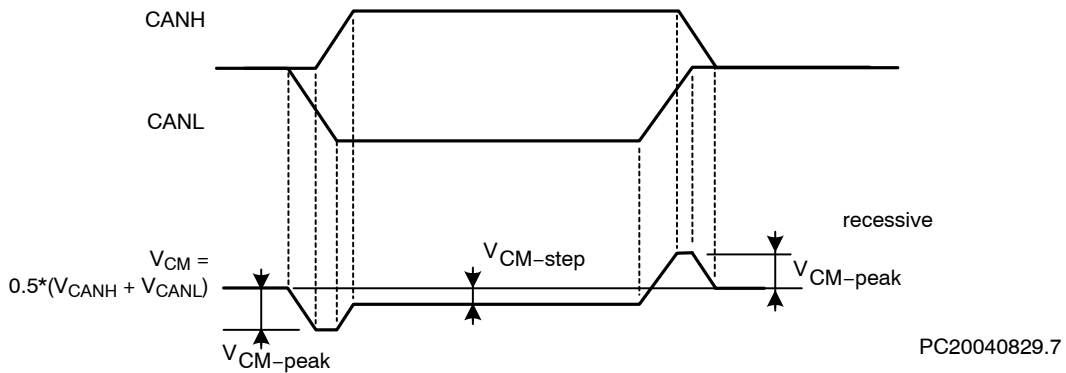

**Figure 8. Common-Mode Voltage Peaks (see Measurement Setup)**

## AMIS-30660

### DEVICE ORDERING INFORMATION

| Part Number      | Description                     | Temperature Range | Package Type        | Shipping†          |
|------------------|---------------------------------|-------------------|---------------------|--------------------|
| AMIS30660CANH2G  | HS CAN Transc. (5 V) (Matte Sn) | -40°C – 125°C     | SOIC-8<br>(Pb-Free) | 96 Tube / Tray     |
| AMIS30660CANH2RG | HS CAN Transc. (5 V) (Matte Sn) | -40°C – 125°C     | SOIC-8<br>(Pb-Free) | 3000 / Tape & Reel |
| AMIS30660CANH6G  | HS CAN Transc. (5 V) (NiPdAu)   | -40°C – 125°C     | SOIC-8<br>(Pb-Free) | 96 Tube / Tray     |
| AMIS30660CANH6RG | HS CAN Transc. (5 V) (NiPdAu)   | -40°C – 125°C     | SOIC-8<br>(Pb-Free) | 3000 / Tape & Reel |

†For information on tape and reel specifications, including part orientation and tape sizes, please refer to our Tape and Reel Packaging Specifications Brochure, BRD8011/D.

# AMIS-30660

## PACKAGE DIMENSIONS

SOIC-8  
CASE 751-07  
ISSUE AK

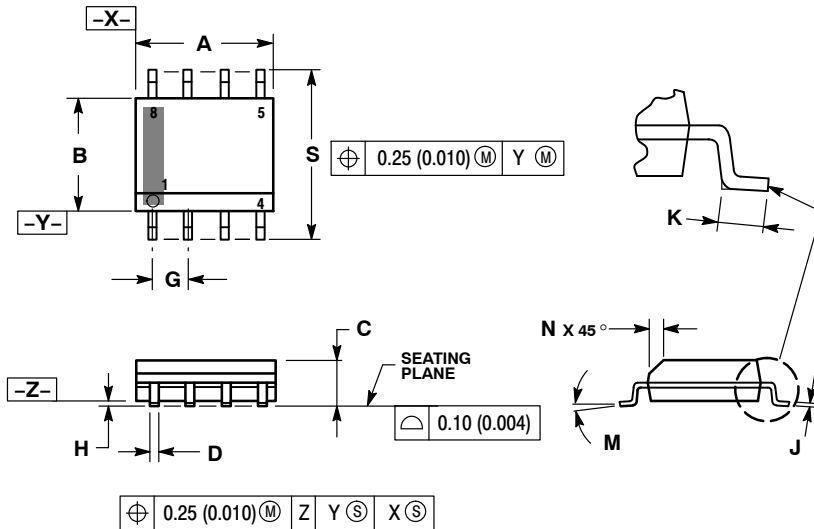

NOTES:

1. DIMENSIONING AND TOLERANCING PER ANSI Y14.5M, 1982.
2. CONTROLLING DIMENSION: MILLIMETER.
3. DIMENSION A AND B DO NOT INCLUDE MOLD PROTRUSION.
4. MAXIMUM MOLD PROTRUSION 0.15 (0.006) PER SIDE.
5. DIMENSION D DOES NOT INCLUDE DAMBAR PROTRUSION. ALLOWABLE DAMBAR PROTRUSION SHALL BE 0.127 (0.005) TOTAL IN EXCESS OF THE D DIMENSION AT MAXIMUM MATERIAL CONDITION.
6. 751-01 THRU 751-06 ARE OBSOLETE. NEW STANDARD IS 751-07.

| DIM | MILLIMETERS |      | INCHES    |       |
|-----|-------------|------|-----------|-------|
|     | MIN         | MAX  | MIN       | MAX   |
| A   | 4.80        | 5.00 | 0.189     | 0.197 |
| B   | 3.80        | 4.00 | 0.150     | 0.157 |
| C   | 1.35        | 1.75 | 0.053     | 0.069 |
| D   | 0.33        | 0.51 | 0.013     | 0.020 |
| G   | 1.27 BSC    |      | 0.050 BSC |       |
| H   | 0.10        | 0.25 | 0.004     | 0.010 |
| J   | 0.19        | 0.25 | 0.007     | 0.010 |
| K   | 0.40        | 1.27 | 0.016     | 0.050 |
| M   | 0° 8°       |      | 0° 8°     |       |
| N   | 0.25        | 0.50 | 0.010     | 0.020 |
| S   | 5.80        | 6.20 | 0.228     | 0.244 |

### SOLDERING FOOTPRINT\*

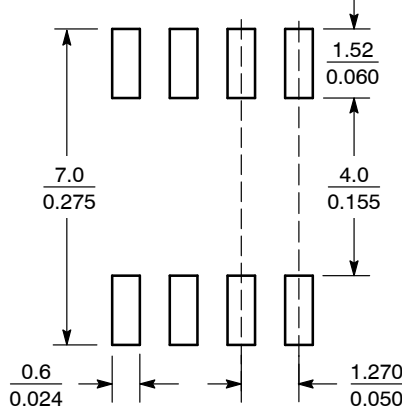

SCALE 6:1 (mm/inches)

\*For additional information on our Pb-Free strategy and soldering details, please download the ON Semiconductor Soldering and Mounting Techniques Reference Manual, SOLDERRM/D.

ON Semiconductor and are registered trademarks of Semiconductor Components Industries, LLC (SCILLC). SCILLC owns the rights to a number of patents, trademarks, copyrights, trade secrets, and other intellectual property. A listing of SCILLC's product/patent coverage may be accessed at [www.onsemi.com/site/pdf/Patent-Marking.pdf](http://www.onsemi.com/site/pdf/Patent-Marking.pdf). SCILLC reserves the right to make changes without further notice to any products herein. SCILLC makes no warranty, representation or guarantee regarding the suitability of its products for any particular purpose, nor does SCILLC assume any liability arising out of the application or use of any product or circuit, and specifically disclaims any and all liability, including without limitation special, consequential or incidental damages. "Typical" parameters which may be provided in SCILLC data sheets and/or specifications can and do vary in different applications and actual performance may vary over time. All operating parameters, including "Typicals" must be validated for each customer application by customer's technical experts. SCILLC does not convey any license under its patent rights nor the rights of others. SCILLC products are not designed, intended, or authorized for use as components in systems intended for surgical implant into the body, or other applications intended to support or sustain life, or for any other application in which the failure of the SCILLC product could create a situation where personal injury or death may occur. Should Buyer purchase or use SCILLC products for any such unintended or unauthorized application, Buyer shall indemnify and hold SCILLC and its officers, employees, subsidiaries, affiliates, and distributors harmless against all claims, costs, damages, and expenses, and reasonable attorney fees arising out of, directly or indirectly, any claim of personal injury or death associated with such unintended or unauthorized use, even if such claim alleges that SCILLC was negligent regarding the design or manufacture of the part. SCILLC is an Equal Opportunity/Affirmative Action Employer. This literature is subject to all applicable copyright laws and is not for resale in any manner.

### PUBLICATION ORDERING INFORMATION

**LITERATURE FULFILLMENT:**  
Literature Distribution Center for ON Semiconductor  
P.O. Box 5163, Denver, Colorado 80217 USA  
**Phone:** 303-675-2175 or 800-344-3860 Toll Free USA/Canada  
**Fax:** 303-675-2176 or 800-344-3867 Toll Free USA/Canada  
**Email:** [orderlit@onsemi.com](mailto:orderlit@onsemi.com)

**N. American Technical Support:** 800-282-9855 Toll Free  
USA/Canada  
**Europe, Middle East and Africa Technical Support:**  
Phone: 421 33 790 2910  
**Japan Customer Focus Center**  
Phone: 81-3-5817-1050

**ON Semiconductor Website:** [www.onsemi.com](http://www.onsemi.com)  
**Order Literature:** <http://www.onsemi.com/orderlit>  
For additional information, please contact your local Sales Representative

## X-ON Electronics

Largest Supplier of Electrical and Electronic Components

*Click to view similar products for [CAN Interface IC category](#):*

*Click to view products by [ON Semiconductor manufacturer](#):*

Other Similar products are found below :

[416694H](#) [MAX33041EASA+T](#) [TJA1042T,118](#) [IL41050TA-1E](#) [TJA1042T1J](#) [TJA1042T31J](#) [SN65LBC031DG4](#) [TJA1050T/CM,118](#)  
[MAX13051ESA+T](#) [SJA1000T/N1.118](#) [MCP2562FD-EP](#) [MCP2561FD-EP](#) [LTM2889IY-5#PBF](#) [ADM3053BRWZ-REEL7](#) [ADM3051CRZ-](#)  
[REEL7](#) [ADM3052BRWZ-REEL7](#) [IA82527PLC44AR2](#) [LT3960JMSE#PBF](#) [TJA1040TCM,118](#) [TD041SCANH](#) [TDH541SCANH](#)  
[SIT1050TK](#) [SIT1040TK](#) [MCP25625-ESS](#) [MAX3053ESA+T](#) [MAX13041ASDV](#) [MAX3057ASA+T](#) [MCP2515T-I/ST](#) [MAX13051ASA+](#)  
[MCP2517FD-H/SL](#) [NCV7341D21R2G](#) [MC33897CTEFR2](#) [MAX3056ASD+](#) [MAX3054ASD+](#) [MAX3055ASD+](#) [MAX3051ESA+T](#)  
[MCP2510-I/P](#) [MCP2510-I/SO](#) [MCP2510-I/ST](#) [MCP2515-E/SO](#) [MCP2515-I/P](#) [MCP2515-I/SO](#) [MCP2515-I/ST](#) [MCP2515T-I/SO](#) [MCP2551-](#)  
[E/P](#) [MCP2551-E/SN](#) [MCP2551-I/P](#) [MCP2551-I/SN](#) [MCP2561-E/P](#) [MCP2561FD-HP](#)