

# ON Semiconductor

## Is Now

# onsemi™

To learn more about onsemi™, please visit our website at  
[www.onsemi.com](http://www.onsemi.com)

---

**onsemi** and **onsemi** and other names, marks, and brands are registered and/or common law trademarks of Semiconductor Components Industries, LLC dba "**onsemi**" or its affiliates and/or subsidiaries in the United States and/or other countries. **onsemi** owns the rights to a number of patents, trademarks, copyrights, trade secrets, and other intellectual property. A listing of **onsemi** product/patent coverage may be accessed at [www.onsemi.com/site/pdf/Patent-Marking.pdf](http://www.onsemi.com/site/pdf/Patent-Marking.pdf). **onsemi** reserves the right to make changes at any time to any products or information herein, without notice. The information herein is provided "as-is" and **onsemi** makes no warranty, representation or guarantee regarding the accuracy of the information, product features, availability, functionality, or suitability of its products for any particular purpose, nor does **onsemi** assume any liability arising out of the application or use of any product or circuit, and specifically disclaims any and all liability, including without limitation special, consequential or incidental damages. Buyer is responsible for its products and applications using **onsemi** products, including compliance with all laws, regulations and safety requirements or standards, regardless of any support or applications information provided by **onsemi**. "Typical" parameters which may be provided in **onsemi** data sheets and/or specifications can and do vary in different applications and actual performance may vary over time. All operating parameters, including "Typicals" must be validated for each customer application by customer's technical experts. **onsemi** does not convey any license under any of its intellectual property rights nor the rights of others. **onsemi** products are not designed, intended, or authorized for use as a critical component in life support systems or any FDA Class 3 medical devices or medical devices with a same or similar classification in a foreign jurisdiction or any devices intended for implantation in the human body. Should Buyer purchase or use **onsemi** products for any such unintended or unauthorized application, Buyer shall indemnify and hold **onsemi** and its officers, employees, subsidiaries, affiliates, and distributors harmless against all claims, costs, damages, and expenses, and reasonable attorney fees arising out of, directly or indirectly, any claim of personal injury or death associated with such unintended or unauthorized use, even if such claim alleges that **onsemi** was negligent regarding the design or manufacture of the part. **onsemi** is an Equal Opportunity/Affirmative Action Employer. This literature is subject to all applicable copyright laws and is not for resale in any manner. Other names and brands may be claimed as the property of others.

# AMIS-42665

## High-Speed Low Power CAN Transceiver

### Description

The AMIS-42665 CAN transceiver is the interface between a controller area network (CAN) protocol controller and the physical bus and may be used in both 12 V and 24 V systems. The transceiver provides differential transmit capability to the bus and differential receive capability to the CAN controller.

Due to the wide common-mode voltage range of the receiver inputs, the AMIS-42665 is able to reach outstanding levels of electromagnetic susceptibility (EMS). Similarly, extremely low electromagnetic emission (EME) is achieved by the excellent matching of the output signals.

The AMIS-42665 is a new addition to the CAN high-speed transceiver family and offers the following additional features:

### Features

- Wake-up (WU) Over Bus
- Voltage Source via  $V_{SPLIT}$  Pin for Stabilizing the Recessive Bus Level (Further EMC Improvement)
- Ideal Passive Behavior when Supply Voltage is Removed
- Extremely Low Current Standby Mode
- Compatible with the ISO 11898 Standard (ISO 11898-2, ISO 11898-5 and SAE J2284)
- High Speed (up to 1 Mbps)
- Ideally Suited for 12 V and 24 V Industrial and Automotive Applications
- Extremely Low Current Standby Mode with Wake-up via the Bus
- Low EME Common-Mode Choke is No Longer Required
- Differential Receiver with Wide Common-Mode Range ( $\pm 35$  V) for High EMS
- Transmit Data (TxD) Dominant Time-out Function
- Thermal Protection
- Bus Pins Protected against Transients in an Automotive Environment
- Power Down Mode in which the Transmitter is Disabled
- Bus and  $V_{SPLIT}$  Pins Short Circuit Proof to Supply Voltage and Ground
- Logic Level Inputs Compatible with 3.3 V Devices
- These are Pb-Free Devices



ON Semiconductor®

<http://onsemi.com>

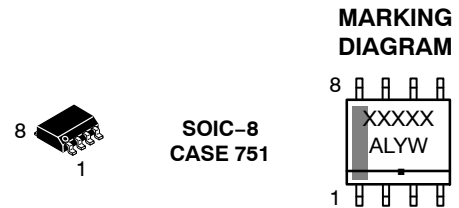

XXXXX = Specific Device Code  
A = Assembly Location  
L = Wafer Lot  
Y = Year  
W = Work Week  
▪ = Pb-Free Package

### PIN ASSIGNMENT

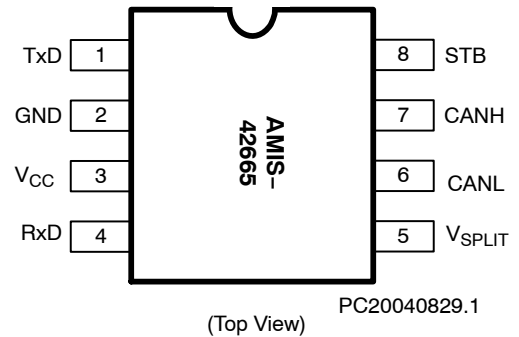

### ORDERING INFORMATION

See detailed ordering and shipping information in the package dimensions section on page 10 of this data sheet.

Table 1. TECHNICAL CHARACTERISTICS

Symbol	Parameter	Conditions	Min	Max	Unit
V <sub>CC</sub>	Power Supply Voltage		4.75	5.25	V
V <sub>STB</sub>	DC Voltage at Pin STB		-0.3	V <sub>CC</sub>	V
V <sub>TxD</sub>	DC Voltage at Pin TxD		-0.3	V <sub>CC</sub>	V
V <sub>RxD</sub>	DC Voltage at Pin RxD		-0.3	V <sub>CC</sub>	V
V <sub>CANH</sub>	DC Voltage at Pin CANH	0 < V <sub>CC</sub> < 5.25 V; No Time Limit	-35	+35	V
V <sub>CANL</sub>	DC Voltage at Pin CANL	0 < V <sub>CC</sub> < 5.25 V; No Time Limit	-35	+35	V
V <sub>SPLIT</sub>	DC Voltage at Pin V <sub>SPLIT</sub>	0 < V <sub>CC</sub> < 5.25 V; No Time Limit	-35	+35	V
V <sub>O(dif)(bus_dom)</sub>	Differential Bus Output Voltage in Dominant State	42.5 Ω < R <sub>LT</sub> < 60 Ω	1.5	3	V
CM-range	Input Common-Mode Range for Comparator	Guaranteed Differential Receiver Threshold and Leakage Current	-35	+35	V
V <sub>CM-peak</sub>	Common-Mode Peak	See Figures 11 and 12	-500	500	mV
C <sub>load</sub>	Load Capacitance on IC Outputs			10	pF
t <sub>pd(rec-dom)</sub>	Propagation Delay TxD to RxD	See Figure 7	90	230	ns
t <sub>pd(dom-rec)</sub>	Propagation Delay TxD to RxD	See Figure 7	90	245	ns
T <sub>J</sub>	Junction Temperature		-40	150	°C

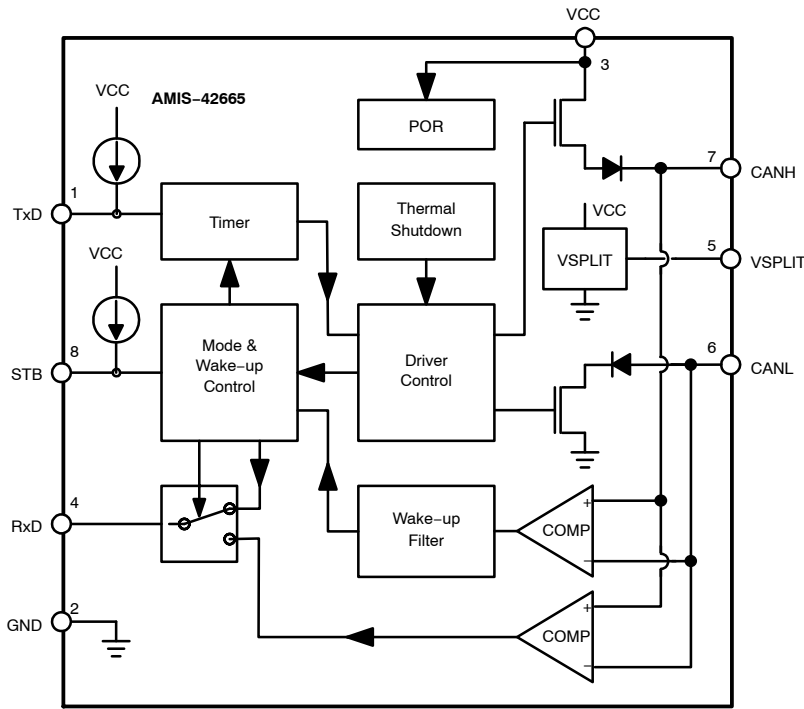

Figure 1. Block Diagram

PC20050211.1

# AMIS-42665

## TYPICAL APPLICATION

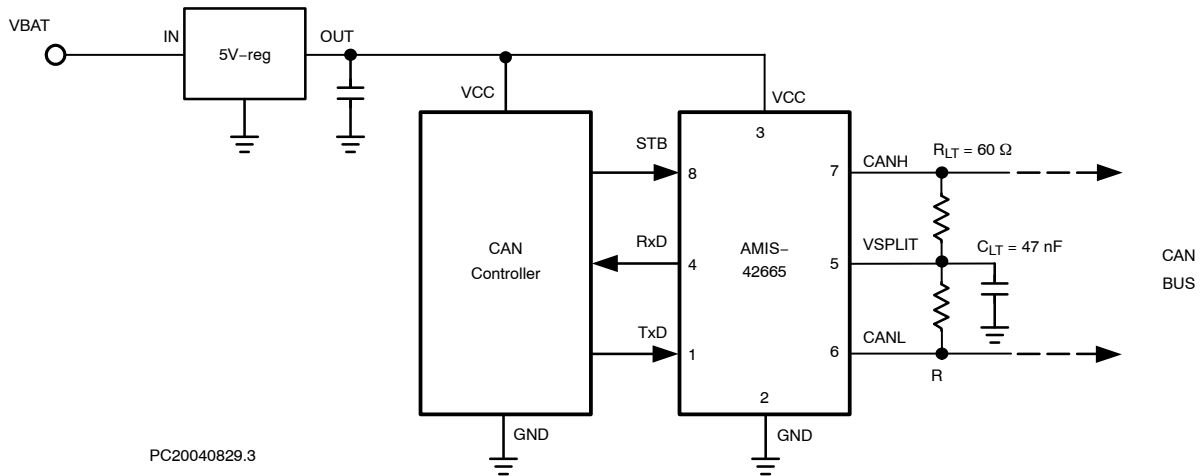

Figure 2. Application Diagram

Table 2. PIN LIST AND DESCRIPTIONS

Pin	Name	Description
1	TxD	Transmit Data Input; Low Input → Dominant Driver; Internal Pullup Current
2	GND	Ground
3	V <sub>CC</sub>	Supply Voltage
4	RxD	Receive Data Output; Dominant transmitter → Low Output
5	V <sub>SPLIT</sub>	Common-Mode Stabilization Output
6	CANL	Low-Level CAN Bus Line (Low in Dominant Mode)
7	CANH	High-Level CAN Bus Line (High in Dominant Mode)
8	STB	Standby Mode Control Input

**Table 3. ABSOLUTE MAXIMUM RATINGS**

Symbol	Parameter	Conditions	Min.	Max.	Unit
V <sub>CC</sub>	Supply Voltage		-0.3	+7	V
V <sub>CANH</sub>	DC Voltage at Pin CANH	0 < V <sub>CC</sub> < 5.25 V; No Time Limit	-50	+50	V
V <sub>CANL</sub>	DC Voltage at Pin CANL	0 < V <sub>CC</sub> < 5.25 V; No Time Limit	-50	+50	V
V <sub>SPLIT</sub>	DC Voltage at Pin V <sub>SPLIT</sub>	0 < V <sub>CC</sub> < 5.25 V; No Time Limit	-50	+50	V
V <sub>TxD</sub>	DC Voltage at Pin TxD		-0.3	V <sub>CC</sub> + 0.3	V
V <sub>RxD</sub>	DC Voltage at Pin RxD		-0.3	V <sub>CC</sub> + 0.3	V
V <sub>STB</sub>	DC Voltage at Pin STB		-0.3	V <sub>CC</sub> + 0.3	V
V <sub>tran(CANH)</sub>	Transient Voltage at Pin CANH	Note 1	-300	+300	V
V <sub>tran(CANL)</sub>	Transient voltage at Pin CANL	Note 1	-300	+300	V
V <sub>tran(VSPLIT)</sub>	Transient Voltage at Pin V <sub>SPLIT</sub>	Note 1	-300	+300	V
V <sub>esd(CANL/CANH/VSPLIT)</sub>	Electrostatic Discharge Voltage at CANH and CANL Pin	Note 2 Note 4	-8 -500	+8 +500	kV V
V <sub>esd</sub>	Electrostatic Discharge Voltage at All Other Pins	Note 2 Note 4	-5 -500	+5 +500	kV V
Latch-up	Static Latch-up at all Pins	Note 3		120	mA
T <sub>stg</sub>	Storage Temperature		-55	+150	°C
T <sub>amb</sub>	Ambient Temperature		-40	+125	°C
T <sub>J</sub>	Maximum Junction Temperature		-40	+170	°C

Stresses exceeding Maximum Ratings may damage the device. Maximum Ratings are stress ratings only. Functional operation above the Recommended Operating Conditions is not implied. Extended exposure to stresses above the Recommended Operating Conditions may affect device reliability.

1. Applied transient waveforms in accordance with ISO 7637 part 3, test pulses 1, 2, 3a, and 3b (see Figure 5).
2. Standardized human body model electrostatic discharge (ESD) pulses in accordance to MIL883 method 3015.7.
3. Static latch-up immunity: Static latch-up protection level when tested according to EIA/JESD78.
4. Standardized charged device model ESD pulses when tested according to EOS/ESD DS5.3-1993.

**Table 4. THERMAL CHARACTERISTICS**

Symbol	Parameter	Conditions	Value	Unit
R <sub>th(vj-a)</sub>	Thermal Resistance from Junction-to-Ambient in SOIC-8 Package	In free air	145	K/W
R <sub>th(vj-s)</sub>	Thermal Resistance from Junction-to-Substrate of Bare Die	In free air	45	K/W

## FUNCTIONAL DESCRIPTION

AMIS-42665 provides two modes of operation as illustrated in Table 5. These modes are selectable through pin STB.

**Table 5. OPERATING MODES**

Mode	Pin STB	Pin RXD	
		Low	High
Normal	Low	Bus Dominant	Bus Recessive
Standby	High	Wake-up Request Detected	No Wake-up Request Detected

### Normal Mode

In the normal mode, the transceiver is able to communicate via the bus lines. The signals are transmitted and received to the CAN controller via the pins TxD and RxD. The slopes on the bus lines outputs are optimized to give extremely low EME.

### Standby Mode

In standby mode both the transmitter and receiver are disabled and a very low-power differential receiver monitors the bus lines for CAN bus activity. The bus lines are terminated to ground and supply current is reduced to a minimum, typically 10 μA. When a wake-up request is

detected by the low-power differential receiver, the signal is first filtered and then verified as a valid wake signal after a time period of  $t_{dbus}$ , the RxD pin is driven low by the transceiver to inform the controller of the wake-up request.

**Split Circuit**

The  $V_{SPLIT}$  Pin is operational only in normal mode. In standby mode this pin is floating. The  $V_{SPLIT}$  is connected as shown in Figure 2 and its purpose is to provide a stabilized DC voltage of  $0.5 \times V_{CC}$  to the bus avoiding possible steps in the common-mode signal therefore reducing EME. These unwanted steps could be caused by an unpowered node on the network with excessive leakage current from the bus that shifts the recessive voltage from its nominal  $0.5 \times V_{CC}$  voltage.

**Wake-up**

When a valid wake-up (dominant state longer than  $t_{dbus}$ ) is received during the standby mode the RxD pin is driven low. Wake-up behavior in case of a permanent dominant – due to, for example, a bus short – represents the only difference between the circuit sub-versions listed in the Ordering Information table. It is depicted in Figures 3 and 4. When the standby mode is entered while a dominant is present on the bus, the “unconditioned bus wake-up” versions will signal a bus-wakeup immediately after the state transition (seen as a High-level glitch on RxD). The other version (differing purely by a metal-level modification in the digital part) will signal bus-wakeup only after the initial dominant is released. In this way it’s ensured, that a CAN bus can be put to a low-power mode even if the nodes have a level sensitivity to RxD pin and a permanent dominant is present on the bus.

**Overtemperature Detection**

A thermal protection circuit protects the IC from damage by switching off the transmitter if the junction temperature exceeds a value of approximately 160°C. Because the transmitter dissipates most of the power, the power dissipation and temperature of the IC are reduced. All other IC functions continue to operate. The transmitter off-state resets when Pin TxD goes high. The thermal protection circuit is particularly needed when a bus line short circuits.

**TxD Dominant Time-out Function**

A TxD dominant time-out timer circuit prevents the bus lines being driven to a permanent dominant state (blocking all network communication) if Pin TxD is forced permanently low by a hardware and/or software application failure. The timer is triggered by a negative edge on pin TxD. If the duration of the low-level on Pin TxD exceeds the internal timer value  $t_{dom(TxD)}$ , the transmitter is disabled, driving the bus into a recessive state. The timer is reset by a positive edge on Pin TxD. See Figure 10.

This TxD dominant time-out time ( $t_{dom(TxD)}$ ) defines the minimum possible bit rate to 40 kbps.

**Fail Safe Features**

A current-limiting circuit protects the transmitter output stage from damage caused by accidental short circuit to either positive or negative supply voltage, although power dissipation increases during this fault condition.

The pins CANH and CANL are protected from automotive electrical transients (according to ISO 7637; see Figure 5). Pins TxD and STB are pulled high internally should the input become disconnected. Pins TxD, STB and RxD will be floating, preventing reverse supply should the  $V_{CC}$  supply be removed.

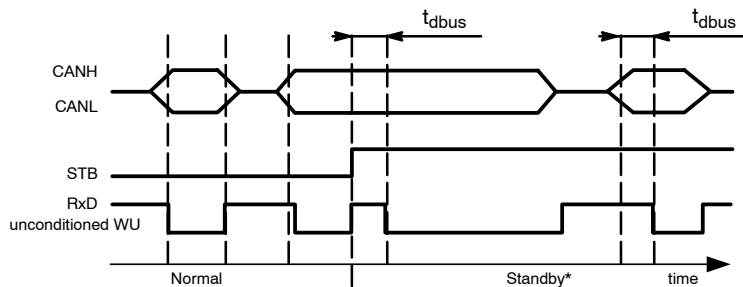

\*Even if bus dominant signals longer than  $t_{dbus}$  are echoed on RxD, the transceiver stays in standby mode until STB is released.

**Figure 3. AMIS42665TJAA1/3 Wake-up Behavior**

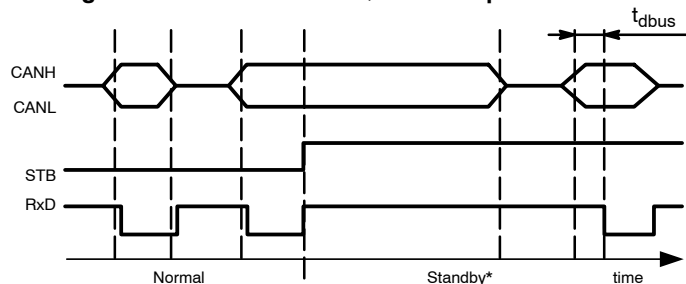

\*On this derivative, bus dominant signals longer than  $t_{dbus}$  are echoed on RxD after the bus passed through a recessive time following the trigger of STB. The transceiver stays in standby mode until STB is released.

**Figure 4. AMIS42665TJAA6 Wake-up Behavior**

ELECTRICAL CHARACTERISTICS

Definitions

All voltages are referenced to GND (Pin 2). Positive currents flow into the IC.

**CHARACTERISTICS**  $V_{CC} = 4.75\text{ V to }5.25\text{ V}$ ;  $T_J = -40^\circ\text{C to }+150^\circ\text{C}$ ;  $R_{LT} = 60\ \Omega$  unless specified otherwise.

Symbol	Parameter	Conditions	Min	Typ	Max	Unit
--------	-----------	------------	-----	-----	-----	------

**SUPPLY (PIN  $V_{CC}$ )**

$I_{CC}$	Supply Current	Dominant; $V_{TXD} = 0\text{ V}$ Recessive; $V_{TXD} = V_{CC}$		45 4	65 8	mA
$I_{CCS}$	Supply Current in Standby Mode	$T_{J,max} = 100^\circ\text{C}$		10	15	$\mu\text{A}$

**TRANSMITTER DATA INPUT (PIN  $TxD$ )**

$V_{IH}$	High-Level Input Voltage	Output Recessive	2.0	-	$V_{CC} + 0.3$	V
$V_{IL}$	Low-Level Input Voltage	Output Dominant	-0.3	-	+0.8	V
$I_{IH}$	High-Level Input Current	$V_{TXD} = V_{CC}$	-5	0	+5	$\mu\text{A}$
$I_{IL}$	Low-Level Input Current	$V_{TXD} = 0\text{ V}$	-75	-200	-350	$\mu\text{A}$
$C_i$	Input Capacitance	Not Tested	-	5	10	pF

**TRANSMITTER MODE SELECT (PIN  $STB$ )**

$V_{IH}$	High-Level Input Voltage	Standby Mode	2.0	-	$V_{CC} + 0.3$	V
$V_{IL}$	Low-Level Input Voltage	Normal Mode	-0.3	-	+0.8	V
$I_{IH}$	High-Level Input Current	$V_{STB} = V_{CC}$	-5	0	+5	$\mu\text{A}$
$I_{IL}$	Low-Level Input Current	$V_{STB} = 0\text{ V}$	-1	-4	-10	$\mu\text{A}$
$C_i$	Input Capacitance	Not Tested	-	5	10	pF

**RECEIVER DATA OUTPUT (PIN  $RxD$ )**

$I_{oh}$	High-Level Output Current	$V_o = 0.7 \times V_{CC}$	-5	-10	-15	mA
$I_{ol}$	Low-Level Output Current	$V_o = 0.3 \times V_{CC}$	5	10	15	mA

**BUS LINES (PINS  $CANH$  AND  $CANL$ )**

$V_{o(reces)} (norm)$	Recessive Bus Voltage Normal Mode	$V_{TXD} = V_{CC}$ ; No Load	2.0	2.5	3.0	V
$V_{o(reces)} (stby)$	Recessive Bus Voltage	$V_{TXD} = V_{CC}$ ; No Load Standby Mode	-100	0	100	mV
$I_{o(reces)} (CANH)$	Recessive Output Current at Pin $CANH$	$-35\text{ V} < V_{CANH} < +35\text{ V}$ ; $0\text{ V} < V_{CC} < 5.25\text{ V}$	-2.5	-	+2.5	mA
$I_{o(reces)} (CANL)$	Recessive Output Current at Pin $CANL$	$-35\text{ V} < V_{CANL} < +35\text{ V}$ ; $0\text{ V} < V_{CC} < 5.25\text{ V}$	-2.5	-	+2.5	mA
$I_{LI}(CANH)$	Input Leakage Current to Pin $CANH$	$V_{CC} = 0\text{ V}$ ; $V_{CANL} = V_{CANH} = 5\text{ V}$	-10	-	+10	$\mu\text{A}$
$I_{LI}(CANL)$	Input Leakage Current to Pin $CANL$	$V_{CC} = 0\text{ V}$ ; $V_{CANL} = V_{CANH} = 5\text{ V}$	-10	-	+10	$\mu\text{A}$
$V_{o(dom)} (CANH)$	Dominant Output Voltage at Pin $CANH$	$V_{TXD} = 0\text{ V}$	3.0	3.6	4.25	V
$V_{o(dom)} (CANL)$	Dominant Output Voltage at Pin $CANL$	$V_{TXD} = 0\text{ V}$	0.5	1.4	1.75	V
$V_{o(dif)} (bus\_dom)$	Differential Bus Output Voltage ( $V_{CANH} - V_{CANL}$ )	$V_{TXD} = 0\text{ V}$ ; Dominant; $42.5\ \Omega < R_{LT} < 60\ \Omega$	1.5	2.25	3.0	V
$V_{o(dif)} (bus\_rec)$	Differential Bus Output Voltage ( $V_{CANH} - V_{CANL}$ )	$V_{TXD} = V_{CC}$ ; Recessive; No Load	-120	0	+50	mV
$I_{o(sc)} (CANH)$	Short Circuit Output Current at Pin $CANH$	$V_{CANH} = 0\text{ V}$ ; $V_{TXD} = 0\text{ V}$	-45	-70	-120	mA

# AMIS-42665

**CHARACTERISTICS**  $V_{CC} = 4.75\text{ V to }5.25\text{ V}$ ;  $T_J = -40^\circ\text{C to }+150^\circ\text{C}$ ;  $R_{LT} = 60\ \Omega$  unless specified otherwise.

Symbol	Parameter	Conditions	Min	Typ	Max	Unit
--------	-----------	------------	-----	-----	-----	------

### BUS LINES (PINS CANH AND CANL)

$I_{o(sc)}$ (CANL)	Short Circuit Output Current at Pin CANL	$V_{CANL} = 36\text{ V}$ ; $V_{TXD} = 0\text{ V}$	45	70	120	mA
$V_{i(dif)}$ (th)	Differential Receiver Threshold Voltage (see Figure 6)	$-5\text{ V} < V_{CANL} < +12\text{ V}$ ; $-5\text{ V} < V_{CANH} < +12\text{ V}$ ;	0.5	0.7	0.9	V
$V_{ihcm(dif)}$ (th)	Differential Receiver Threshold Voltage for High Common-Mode (See Figure 6)	$-35\text{ V} < V_{CANL} < +35\text{ V}$ ; $-35\text{ V} < V_{CANH} < +35\text{ V}$ ;	0.40	0.7	1.00	V
$V_{i(dif)}$ (hys)	Differential Receiver Input Voltage Hysteresis (see Figure 6)	$-35\text{ V} < V_{CANL} < +35\text{ V}$ ; $-35\text{ V} < V_{CANH} < +35\text{ V}$ ;	50	70	100	mV
$R_{i(cm)}$ (CANH)	Common-Mode Input Resistance at Pin CANH		15	26	37	k $\Omega$
$R_{i(cm)}$ (CANL)	Common-Mode Input Resistance at Pin CANL		15	26	37	k $\Omega$
$R_{i(cm)}$ (m)	Matching Between Pin CANH and Pin CANL Common Mode Input Resistance	$V_{CANH} = V_{CANL}$	-3	0	+3	%
$R_{i(dif)}$	Differential Input Resistance		25	50	75	k $\Omega$
$C_{i(CANH)}$	Input Capacitance at Pin CANH	$V_{TXD} = V_{CC}$ ; Not Tested		7.5	20	pF
$C_{i(CANL)}$	Input Capacitance at Pin CANL	$V_{TXD} = V_{CC}$ ; Not Tested		7.5	20	pF
$C_{i(dif)}$	Differential Input Capacitance	$V_{TXD} = V_{CC}$ ; Not Tested		3.75	10	pF

### COMMON-MODE STABILIZATION (PIN $V_{SPLIT}$ )

$V_{SPLIT}$	Reference Output Voltage at Pin $V_{SPLIT}$	Normal Mode; $-500\ \mu\text{A} < I_{SPLIT} < 500\ \mu\text{A}$	$0.3 \times V_{CC}$	-	$0.7 \times V_{CC}$	
$I_{SPLIT(i)}$	$V_{SPLIT}$ Leakage Current	Standby Mode	-5		+5	$\mu\text{A}$
$I_{SPLIT(lim)}$	$V_{SPLIT}$ Limitation Current	Normal Mode	-3		+3	mA

### POWER-ON-RESET (POR)

PORL	POR Level	CANH, CANL in Tri-State Below POR Level	2.2	3.5	4.5	V
------	-----------	---	-----	-----	-----	---

### THERMAL SHUTDOWN

$T_{J(sd)}$	Shutdown Junction Temperature		150	160	180	$^\circ\text{C}$
-------------	-------------------------------	--	-----	-----	-----	------------------

### TIMING CHARACTERISTICS (see Figures 7 and 8)

$t_{d(TxD-BUSon)}$	Delay TXD to Bus Active	$C_I = 100\text{ pF}$ Between CANH to CANL	40	85	105	ns
$t_{d(TxD-BUSoff)}$	Delay TXD to Bus Inactive	$C_I = 100\text{ pF}$ Between CANH to CANL	30	60	105	ns
$t_{d(BUSon-RXD)}$	Delay Bus Active to RXD	$C_{rxd} = 15\text{ pF}$	25	55	105	ns
$t_{d(BUSoff-RXD)}$	Delay Bus Inactive to RXD	$C_{rxd} = 15\text{ pF}$	40	100	105	ns
$t_{pd(rec-dom)}$	Propagation Delay TXD to RXD from Recessive-to-Dominant	$C_I = 100\text{ pF}$ Between CANH to CANL	90		230	ns
$t_{d(dom-rec)}$	Propagation Delay TXD to RXD from Dominant-to-Recessive	$C_I = 100\text{ pF}$ Between CANH to CANL	90		245	ns
$t_{d(stb-nm)}$	Delay Standby Mode to Normal Mode		5	7.5	10	$\mu\text{s}$
$t_{dbus}$	Dominant Time for Wake-up via Bus		0.75	2.5	5	$\mu\text{s}$
$t_{dom(TxD)}$	TxD Dominant Time for Time Out	$V_{TXD} = 0\text{ V}$	300	650	1000	$\mu\text{s}$
Baudrate	Communication Speed Achievable		40k		1M	bps



MEASUREMENT SETUPS AND DEFINITIONS

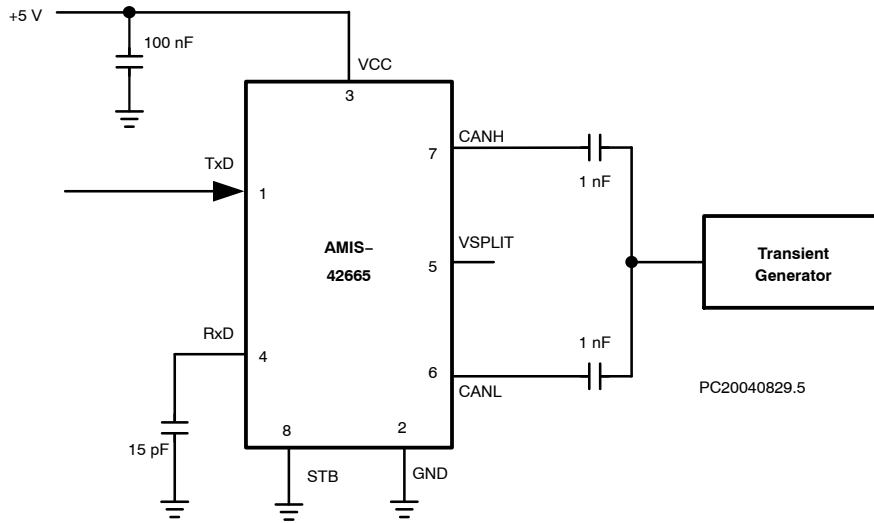

Figure 5. Test Circuit for Automotive Transients

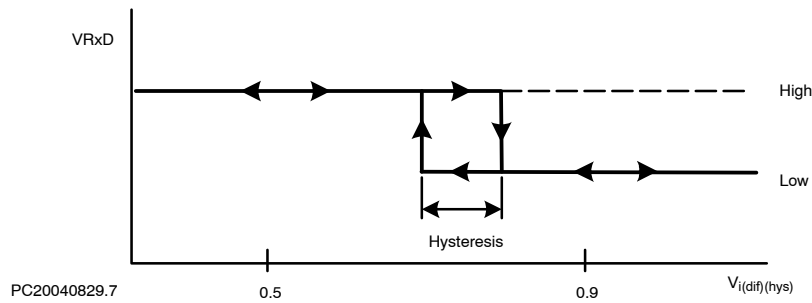

Figure 6. Hysteresis of the Receiver

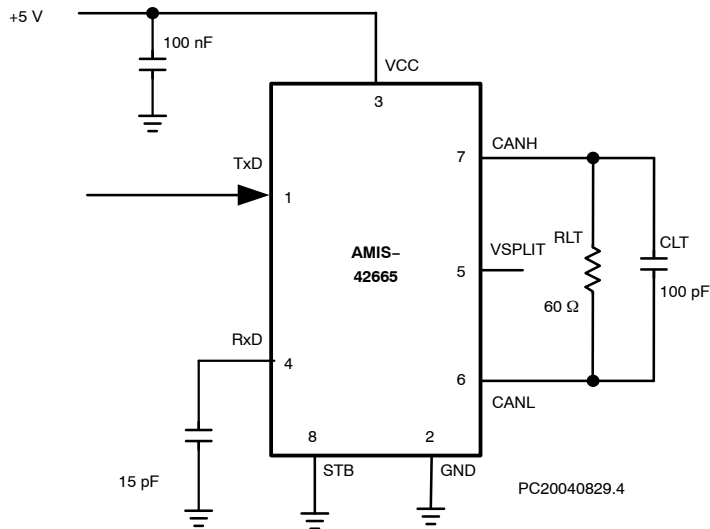
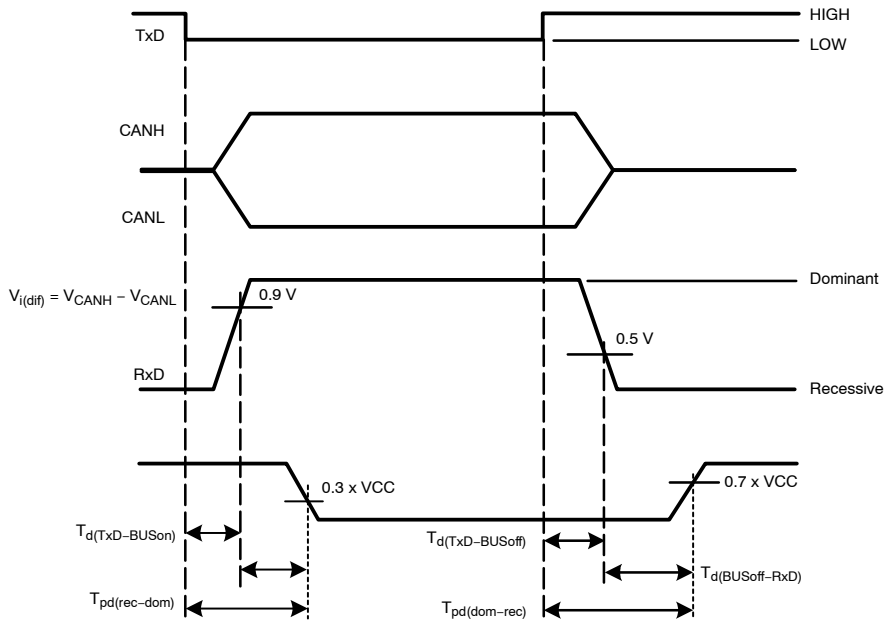

Figure 7. : Test Circuit for Timing Characteristics



PC20040829.6

Figure 8. Timing Diagram for AC Characteristics

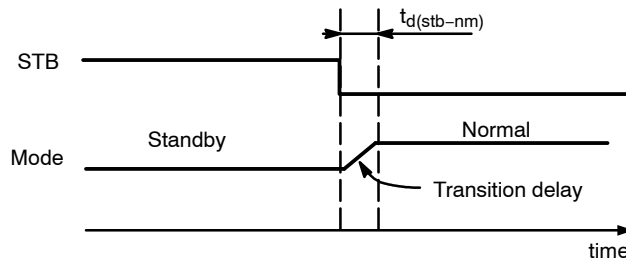

Figure 9. Transition from Standby to Normal

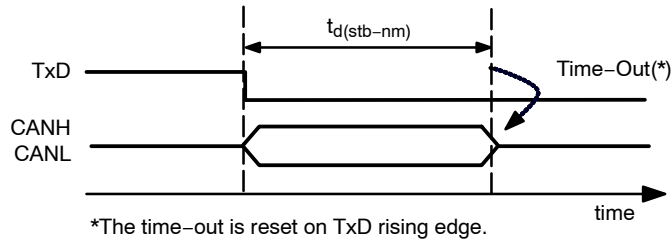

Figure 10. AMIS-42665 TxD Time-Out Bus Blockage Prevention in Case of Controller Failure

# AMIS-42665

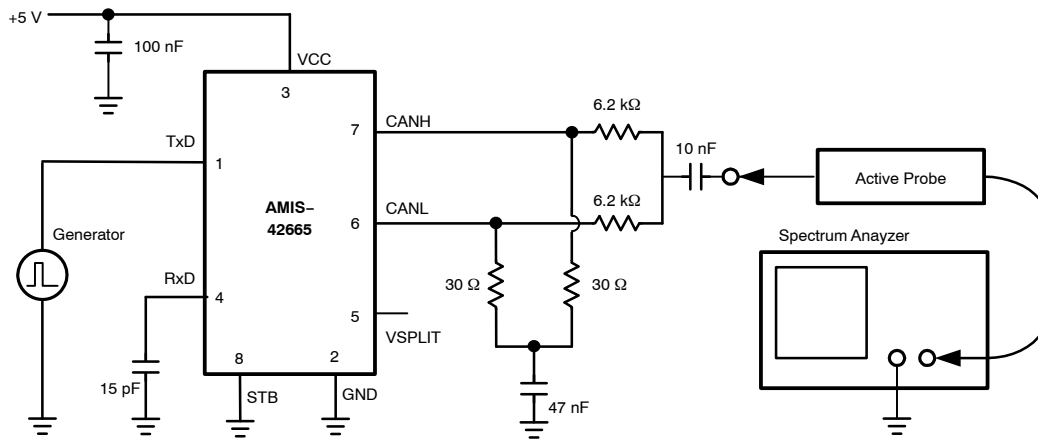

Figure 11. Basic Test Setup for Electromagnetic Measurement

PC20040829.9

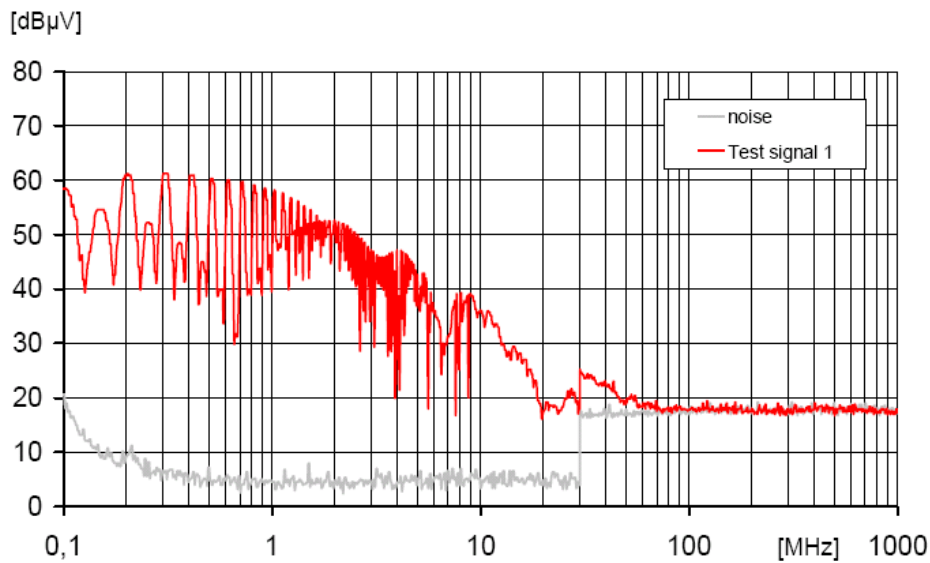

Figure 12. EME Measurements

## DEVICE ORDERING INFORMATION

Part Number	Version	Temperature Range	Package Type	Shipping <sup>†</sup>
AMIS42665TJAA1G	Unconditioned Bus Wake-up	-40°C - 125°C	SOIC-8* (Pb-Free)	96 Tube / Tray
AMIS42665TJAA1RG		-40°C - 125°C	SOIC-8* (Pb-Free)	3000 / Tape & Reel
AMIS42665TJAA3L		-40°C - 125°C	SOIC-8** (Pb-Free)	96 Tube / Tray
AMIS42665TJAA3RL		-40°C - 125°C	SOIC-8** (Pb-Free)	3000 / Tape & Reel
AMIS42665TJAA6G	Bus Wake-up Inactive in Case of Bus Fault	-40°C - 125°C	SOIC-8* (Pb-Free)	96 Tube / Tray
AMIS42665TJAA6RG		-40°C - 125°C	SOIC-8* (Pb-Free)	2000 / Tape & Reel

<sup>†</sup>For information on tape and reel specifications, including part orientation and tape sizes, please refer to our Tape and Reel Packaging Specifications Brochure, BRD8011/D.

\*Matte Sn, JEDEC MS-012

\*\* NiPdAu, JEDEC MS-012

# AMIS-42665

## PACKAGE DIMENSIONS

### SOIC-8 CASE 751-07 ISSUE AK

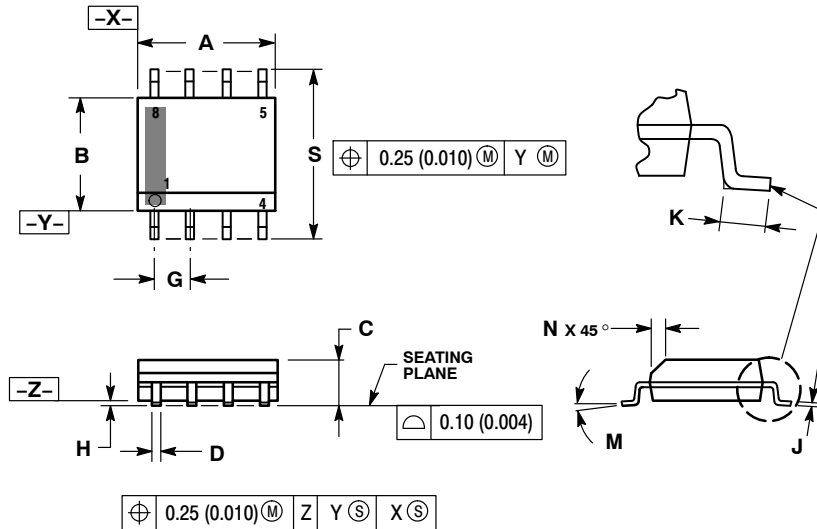

#### NOTES:

1. DIMENSIONING AND TOLERANCING PER ANSI Y14.5M, 1982.
2. CONTROLLING DIMENSION: MILLIMETER.
3. DIMENSION A AND B DO NOT INCLUDE MOLD PROTRUSION.
4. MAXIMUM MOLD PROTRUSION 0.15 (0.006) PER SIDE.
5. DIMENSION D DOES NOT INCLUDE DAMBAR PROTRUSION. ALLOWABLE DAMBAR PROTRUSION SHALL BE 0.127 (0.005) TOTAL IN EXCESS OF THE D DIMENSION AT MAXIMUM MATERIAL CONDITION.
6. 751-01 THRU 751-06 ARE OBSOLETE. NEW STANDARD IS 751-07.

DIM	MILLIMETERS		INCHES	
	MIN	MAX	MIN	MAX
A	4.80	5.00	0.189	0.197
B	3.80	4.00	0.150	0.157
C	1.35	1.75	0.053	0.069
D	0.33	0.51	0.013	0.020
G	1.27 BSC		0.050 BSC	
H	0.10	0.25	0.004	0.010
J	0.19	0.25	0.007	0.010
K	0.40	1.27	0.016	0.050
M	0°	8°	0°	8°
N	0.25	0.50	0.010	0.020
S	5.80	6.20	0.228	0.244

#### SOLDERING FOOTPRINT\*

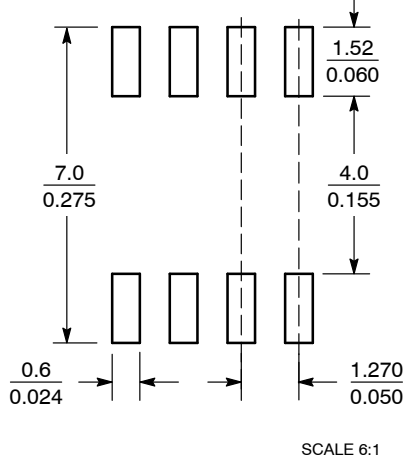

\*For additional information on our Pb-Free strategy and soldering details, please download the ON Semiconductor Soldering and Mounting Techniques Reference Manual, SOLDERRM/D.

ON Semiconductor and are registered trademarks of Semiconductor Components Industries, LLC (SCILLC). SCILLC owns the rights to a number of patents, trademarks, copyrights, trade secrets, and other intellectual property. A listing of SCILLC's product/patent coverage may be accessed at [www.onsemi.com/site/pdf/Patent-Marking.pdf](http://www.onsemi.com/site/pdf/Patent-Marking.pdf). SCILLC reserves the right to make changes without further notice to any products herein. SCILLC makes no warranty, representation or guarantee regarding the suitability of its products for any particular purpose, nor does SCILLC assume any liability arising out of the application or use of any product or circuit, and specifically disclaims any and all liability, including without limitation special, consequential or incidental damages. "Typical" parameters which may be provided in SCILLC data sheets and/or specifications can and do vary in different applications and actual performance may vary over time. All operating parameters, including "Typicals" must be validated for each customer application by customer's technical experts. SCILLC does not convey any license under its patent rights nor the rights of others. SCILLC products are not designed, intended, or authorized for use as components in systems intended for surgical implant into the body, or other applications intended to support or sustain life, or for any other application in which the failure of the SCILLC product could create a situation where personal injury or death may occur. Should Buyer purchase or use SCILLC products for any such unintended or unauthorized application, Buyer shall indemnify and hold SCILLC and its officers, employees, subsidiaries, affiliates, and distributors harmless against all claims, costs, damages, and expenses, and reasonable attorney fees arising out of, directly or indirectly, any claim of personal injury or death associated with such unintended or unauthorized use, even if such claim alleges that SCILLC was negligent regarding the design or manufacture of the part. SCILLC is an Equal Opportunity/Affirmative Action Employer. This literature is subject to all applicable copyright laws and is not for resale in any manner.

#### PUBLICATION ORDERING INFORMATION

##### LITERATURE FULFILLMENT:

Literature Distribution Center for ON Semiconductor  
P.O. Box 5163, Denver, Colorado 80217 USA  
Phone: 303-675-2175 or 800-344-3860 Toll Free USA/Canada  
Fax: 303-675-2176 or 800-344-3867 Toll Free USA/Canada  
Email: [orderlit@onsemi.com](mailto:orderlit@onsemi.com)

**N. American Technical Support:** 800-282-9855 Toll Free  
USA/Canada  
**Europe, Middle East and Africa Technical Support:**  
Phone: 421 33 790 2910  
**Japan Customer Focus Center**  
Phone: 81-3-5817-1050

**ON Semiconductor Website:** [www.onsemi.com](http://www.onsemi.com)

**Order Literature:** <http://www.onsemi.com/orderlit>

For additional information, please contact your local Sales Representative

## X-ON Electronics

Largest Supplier of Electrical and Electronic Components

*Click to view similar products for [CAN Interface IC category](#):*

*Click to view products by [ON Semiconductor manufacturer](#):*

Other Similar products are found below :

[416694H](#) [MAX33041EASA+T](#) [IL41050TA-1E](#) [TJA1042T1J](#) [TJA1042T31J](#) [SN65LBC031DG4](#) [TJA1050T/CM,118](#) [MAX13051ESA+T](#)  
[SJA1000T/N1.118](#) [MCP2562FD-EP](#) [MCP2561FD-EP](#) [LTM2889IY-5#PBF](#) [IA82527PQF44AR2](#) [ADM3053BRWZ-REEL7](#) [ADM3051CRZ-](#)  
[REEL7](#) [ADM3052BRWZ-REEL7](#) [IA82527PLC44AR2](#) [LT3960JMSE#TRPBF](#) [LT3960JMSE#PBF](#) [TJA1040TCM,118](#) [TD041SCANH](#)  
[TDH541SCANH](#) [SIT1050TK](#) [SIT1040TK](#) [MCP25625-ESS](#) [MAX3053ESA+T](#) [MAX13041ASDV](#) [MAX3057ASA+T](#) [MCP2515T-I/ST](#)  
[MAX13051ASA+](#) [NCV7341D21R2G](#) [MC33897CTEFR2](#) [MAX3056ASD+](#) [MAX3054ASD+](#) [MAX3055ASD+](#) [MAX3051ESA+T](#)  
[MCP2510-I/P](#) [MCP2510-I/SO](#) [MCP2515-I/P](#) [MCP2515-I/SO](#) [MCP2515-I/ST](#) [MCP2515T-I/SO](#) [MCP2551-E/P](#) [MCP2551-E/SN](#) [MCP2551-](#)  
[I/P](#) [MCP2551-I/SN](#) [MCP2561-E/P](#) [MCP2561FD-HP](#) [MCP2561-H/SN](#) [MCP2561T-ESN](#)