

# Advanced High Performance ASK and FSK Narrow-band Transceiver for 27-1050 MHz Range

## AX5043

### OVERVIEW

#### Features

Advanced Multi-channel Narrow-band Single Chip UHF Transceiver (FSK/MSK/4-FSK/GFSK/GMSK/ASK/AFSK/FM/PSK)

#### Low-Power

- RX
  - 9.5 mA @ 868 MHz and 433 MHz
  - 6.5 mA @ 169 MHz
- TX at 868 MHz
  - 7.5 mA @ 0 dBm
  - 16 mA @ 10 dBm
  - 48 mA @ 16 dBm
- 50 nA Deep Sleep Current
- 500 nA Power-down Current with Low Frequency Duty Cycle Clock Running

#### Extended Supply Voltage Range

- 1.8 V – 3.6 V Single Supply

#### High Sensitivity / High Selectivity Receiver

- Data Rates from 0.1 kbps to 125 kbps
- Optional Forward Error Correction (FEC)
- Sensitivity without FEC
  - 135 dBm @ 0.1 kbps, 868 MHz, FSK
  - 126 dBm @ 1 kbps, 868 MHz, FSK
  - 117 dBm @ 10 kbps, 868 MHz, FSK
  - 107 dBm @ 100 kbps, 868 MHz, FSK
  - 105 dBm @ 125 kbps, 868 MHz, FSK
  - 138 dBm @ 0.1 kbps, 868 MHz, PSK
  - 130 dBm @ 1 kbps, 868 MHz, PSK
  - 120 dBm @ 10 kbps, 868 MHz, PSK
  - 109 dBm @ 100 kbps, 868 MHz, PSK
  - 108 dBm @ 125 kbps, 868 MHz, PSK
- Sensitivity with FEC
  - 137 dBm @ 0.1 kbps, 868 MHz, FSK
  - 122 dBm @ 5 kbps, 868 MHz, FSK
  - 111 dBm @ 50 kbps, 868 MHz, FSK
- High Selectivity Receiver with up to 47 dB Adjacent Channel Rejection

- 0 dBm Maximum Input Power
- > ±10% Data-rate Error Tolerance
- Support for Antenna Diversity with External Antenna Switch
- Short Preamble Modes allow the Receiver to work with as little as 16 Preamble Bits
- Fast State Switching Times
  - 200 μs TX → RX Switching Time
  - 62 μs RX → TX Switching Time

#### Transmitter

- Data-rates from 0.1 kbps to 125 kbps
- High Efficiency, High Linearity Integrated Power Amplifier
- Maximum Output Power
  - 16 dBm @ 868 MHz
  - 16 dBm @ 433 MHz
  - 16 dBm @ 169 MHz
- Power Level programmable in 0.5 dB Steps
- GFSK Shaping with BT = 0.3 or BT = 0.5
- Unrestricted Power Ramp Shaping

#### Frequency Generation

- Configurable for Usage in 27 MHz –1050 MHz Bands
- RF Carrier Frequency and FSK Deviation Programmable in 1 Hz Steps
- Ultra Fast Settling RF Frequency Synthesizer for Low-power Consumption
- Fully Integrated RF Frequency Synthesizer with VCO Auto-ranging and Band-width Boost Modes for Fast Locking
- Configurable for either Fully Integrated VCO, Internal VCO with External Inductor or Fully External VCO
- Configurable for either Fully Integrated or External Synthesizer Loop Filter for a Large Range of Bandwidths
- Channel Hopping up to 2000 hops/s
- Automatic Frequency Control (AFC)

## AX5043

### Flexible Antenna Interface

- Integrated RX/TX Switching with Differential Antenna Pins
- Mode with Differential RX Pins and Single-ended TX Pin for Usage with External PAs and for Maximum PA Efficiency at Low Output Power

### Wakeup-on-Radio

- 640 Hz or 10 kHz Lowest Power Wake-up Timer
- Wake-up Time Interval programmable between 98  $\mu$ s and 102 s

### Sophisticated Radio Controller

- Antenna Diversity and Optional External RX/TX Switch Control
- Fully Automatic Packet Reception and Transmission without Micro-controller Intervention
- Supports HDLC, Raw, Wireless M-Bus Frames and Arbitrary Defined Frames
- Automatic Channel Noise Level Tracking
- $\mu$ s Resolution Timestamps for Exact Timing (eg. for Frequency Hopping Systems)
- 256 Byte Micro-programmable FIFO, optionally supports Packet Sizes > 256 Bytes
- Three Matching Units for Preamble Byte, Sync-word and Address
- Ability to store RSSI, Frequency Offset and Data-rate Offset with the Packet Data
- Multiple Receiver Parameter Sets allow the use of more aggressive Receiver Parameters during Preamble, dramatically shortening the Required Preamble Length at no Sensitivity Degradation

### Advanced Crystal Oscillator (RF Reference Oscillator)

- Fast Start-up and Lowest Power Steady-state XTAL Oscillator for a Wide Range of Crystals
- Integrated Crystal Tuning Capacitors
- Possibility of Applying an External Clock Reference (TCXO)

### Miscellaneous Features

- Few External Components
- SPI Microcontroller Interface
- Extended AXSEM Register Set
- Fully Integrated Current/Voltage References
- QFN28 5 mm x 5 mm Package
- Internal Power-on-Reset
- Brown-out Detection
- 10 Bit 1 MS/s General Purpose ADC (GPADC)

### Applications

#### 27 – 1050 MHz Licensed and Unlicensed Radio Systems

- Internet of Things
- Automatic Meter Reading (AMR)
- Security Applications
- Building Automation
- Wireless Networks
- Messaging Paging
- Compatible with: Wireless M-Bus, POCSAG, FLEX, KNX, Sigfox, Z-Wave, enocean
- Regulatory Regimes: EN 300 220 V2.3.1 including the Narrow-band 12.5 kHz, 20 kHz and 25 kHz Definitions; EN 300 422; FCC Part 15.247; FCC Part 15.249; FCC Part 90 6.25 kHz, 12.5 kHz and 25 kHz

# AX5043

## BLOCK DIAGRAM

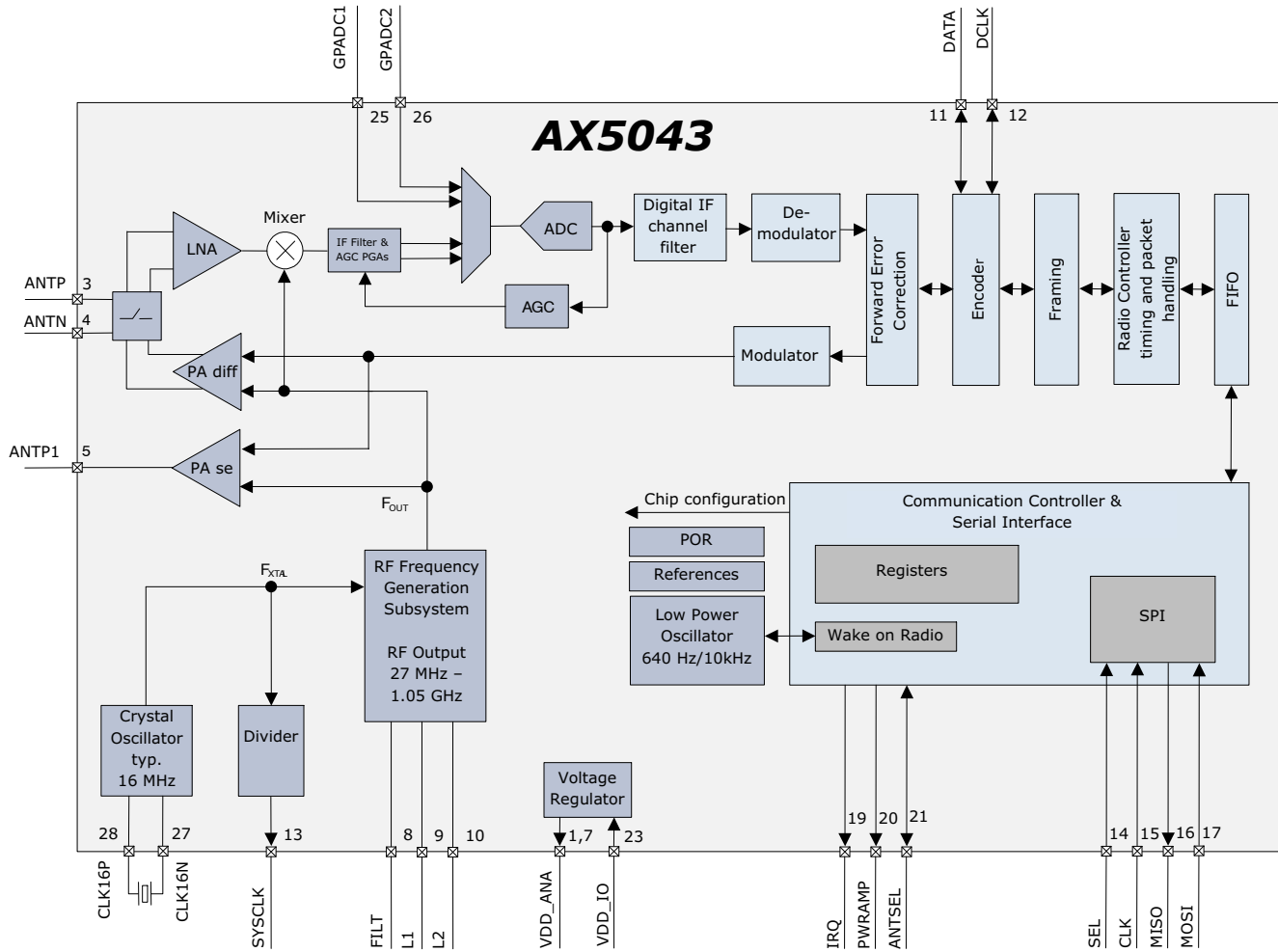

Figure 1. Functional Block Diagram of the AX5043

## AX5043

**Table 1. PIN FUNCTION DESCRIPTIONS**

| Symbol  | Pin(s)     | Type | Description  |
|---------|------------|------|--|
| VDD_ANA | 1          | P    | Analog power output, decouple to neighboring GND   |
| GND     | 2          | P    | Ground, decouple to neighboring VDD_ANA  |
| ANTP    | 3          | A    | Differential antenna input/output  |
| ANTN    | 4          | A    | Differential antenna input/output  |
| ANTP1   | 5          | A    | Single-ended antenna output  |
| GND     | 6          | P    | Ground, decouple to neighboring VDD_ANA  |
| VDD_ANA | 7          | P    | Analog power output, decouple to neighboring GND   |
| FILT    | 8          | A    | Optional synthesizer filter  |
| L2      | 9          | A    | Optional synthesizer inductor, should be shorted with L1 if not used.  |
| L1      | 10         | A    | Optional synthesizer inductor, should be shorted with L2 if not used.  |
| DATA    | 11         | I/O  | In wire mode: Data input/output<br>Can be programmed to be used as a general purpose I/O pin<br>Selectable internal 65 kΩ pull-up resistor                                     |
| DCLK    | 12         | I/O  | In wire mode: Clock output<br>Can be programmed to be used as a general purpose I/O pin<br>Selectable internal 65 kΩ pull-up resistor  |
| SYSClk  | 13         | I/O  | Default functionality: Crystal oscillator (or divided) clock output<br>Can be programmed to be used as a general purpose I/O pin<br>Selectable internal 65 kΩ pull-up resistor |
| SEL     | 14         | I    | Serial peripheral interface select   |
| CLK     | 15         | I    | Serial peripheral interface clock  |
| MISO    | 16         | O    | Serial peripheral interface data output  |
| MOSI    | 17         | I    | Serial peripheral interface data input   |
| NC      | 18         | N    | Must be left unconnected   |
| IRQ     | 19         | I/O  | Default functionality: Transmit and receive interrupt<br>Can be programmed to be used as a general purpose I/O pin<br>Selectable internal 65 kΩ pull-up resistor               |
| PWRAMP  | 20         | I/O  | Default functionality: Power amplifier control output<br>Can be programmed to be used as a general purpose I/O pin<br>Selectable internal 65 kΩ pull-up resistor               |
| ANTSEL  | 21         | I/O  | Default functionality: Diversity antenna selection output<br>Can be programmed to be used as a general purpose I/O pin<br>Selectable internal 65 kΩ pull-up resistor           |
| NC      | 22         | N    | Must be left unconnected   |
| VDD_IO  | 23         | P    | Power supply 1.8 V – 3.3 V   |
| NC      | 24         | N    | Must be left unconnected   |
| GPADC1  | 25         | A    | GPADC input, must be connected to GND if not used  |
| GPADC2  | 26         | A    | GPADC input, must be connected to GND if not used  |
| CLK16N  | 27         | A    | Crystal oscillator input/output  |
| CLK16P  | 28         | A    | Crystal oscillator input/output  |
| GND     | Center pad | P    | Ground on center pad of QFN, must be connected   |

A = analog input  
 I = digital input signal  
 O = digital output signal  
 I/O = digital input/output signal  
 N = not to be connected  
 P = power or ground

All digital inputs are Schmitt trigger inputs, digital input and output levels are LVCMOS/LVTTL compatible and 5 V tolerant.

# AX5043

## Pinout Drawing

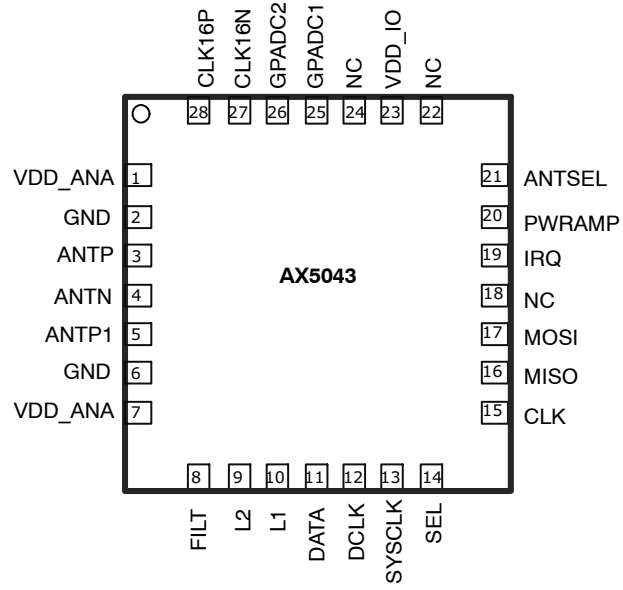

Figure 2. Pinout Drawing (Top View)

**SPECIFICATIONS**

**Table 2. ABSOLUTE MAXIMUM RATINGS**

| Symbol           | Description                                      | Condition                     | Min   | Max  | Units |
|------------------|--|-------------------------------|-------|------|-------|
| VDD_IO           | Supply voltage                                   |                               | -0.5  | 5.5  | V     |
| IDD              | Supply current                                   |                               |       | 200  | mA    |
| P <sub>tot</sub> | Total power consumption                          |                               |       | 800  | mW    |
| P <sub>i</sub>   | Absolute maximum input power at receiver input   | ANTP and ANTN pins in RX mode |       | 10   | dBm   |
| I <sub>I1</sub>  | DC current into any pin except ANTP, ANTN, ANTP1 |                               | -10   | 10   | mA    |
| I <sub>I2</sub>  | DC current into pins ANTP, ANTN, ANTP1           |                               | -100  | 100  | mA    |
| I <sub>O</sub>   | Output Current                                   |                               |       | 40   | mA    |
| V <sub>ia</sub>  | Input voltage ANTP, ANTN, ANTP1 pins             |                               | -0.5  | 5.5  | V     |
|                  | Input voltage digital pins                       |                               | -0.5  | 5.5  | V     |
| V <sub>es</sub>  | Electrostatic handling                           | HBM                           | -2000 | 2000 | V     |
| T <sub>amb</sub> | Operating temperature                            |                               | -40   | 85   | °C    |
| T <sub>stg</sub> | Storage temperature                              |                               | -65   | 150  | °C    |
| T <sub>j</sub>   | Junction Temperature                             |                               |       | 150  | °C    |

Stresses exceeding those listed in the Maximum Ratings table may damage the device. If any of these limits are exceeded, device functionality should not be assumed, damage may occur and reliability may be affected.

1. Exposure to absolute maximum rating conditions for extended periods may affect device reliability.

**DC Characteristics**

**Table 3. SUPPLIES**

| Symbol              | Description  | Condition                  | Min | Typ | Max | Units |
|---------------------|--|----------------------------|-----|-----|-----|-------|
| T <sub>AMB</sub>    | Operational ambient temperature  |                            | -40 | 27  | 85  | °C    |
| VDD_IO              | I/O and voltage regulator supply voltage   |                            | 1.8 | 3.0 | 3.6 | V     |
| V <sub>BOUT</sub>   | Brown-out threshold  | Note 1                     |     | 1.3 |     | V     |
| I <sub>DSLLEP</sub> | Deep Sleep current:<br>All analog and digital functions are powered down                                     | PWRMODE = 0x01             |     | 50  |     | nA    |
| I <sub>PDOWN</sub>  | Power-down current:<br>Register file contents preserved  | PWRMODE = 0x00             |     | 400 |     | nA    |
| I <sub>WOR</sub>    | Wakeup-on-radio mode:<br>Low power timer and WOR state-machine are running at 640 Hz                         | PWRMODE = 0x0B             |     | 500 |     | nA    |
| I <sub>STANBY</sub> | Standby-current:<br>All power domains are powered up, crystal oscillator and references are running          | PWRMODE = 0x05             |     | 230 |     | µA    |
| I <sub>RX</sub>     | Current consumption RX<br>PWRMODE = 0x09<br>RF Frequency Subsystem:<br>Internal VCO and internal loop-filter | 868 MHz, datarate 6 kbps   |     | 9.5 |     | mA    |
|                     |  | 169 MHz, datarate 6 kbps   |     | 6.5 |     |       |
|                     |  | 868 MHz, datarate 100 kbps |     | 11  |     |       |
|                     |  | 169 MHz, datarate 100 kbps |     | 7.5 |     |       |

1. Digital circuitry is functional down to typically 1 V.
2. Measured with optimized matching networks.

**Table 3. SUPPLIES**

| Symbol               | Description                         | Condition  | Min | Typ | Max | Units |
|----------------------|-------------------------------------|--|-----|-----|-----|-------|
| I <sub>TX-DIFF</sub> | Current consumption TX differential | 868 MHz, 16 dBm, FSK, Note 2<br>RF Frequency Subsystem:<br>Internal VCO and loop-filter<br>Antenna configuration: Differential PA                      |     | 48  |     | mA    |
| I <sub>TX-SE</sub>   | Current consumption TX single ended | 868 MHz, 0 dBm, FSK,<br>RF Frequency Subsystem:<br>Internal VCO and loop-filter<br>Antenna configuration:<br>Single ended PA, external RX/TX switching |     | 7.5 |     | mA    |

1. Digital circuitry is functional down to typically 1 V.
2. Measured with optimized matching networks.

For information on current consumption in complex modes of operation tailored to your application, see the software AX-RadioLab for AX5043.

*Note on current consumption in TX mode*

To achieve best output power the matching network has to be optimized for the desired output power and frequency. As a rule of thumb a good matching network produces about 50% efficiency with the AX5043 power amplifier although over 90% are theoretically possible. A typical matching network has between 1 dB and 2 dB loss (P<sub>loss</sub>). The theoretical efficiencies are the same for the single ended PA (ANTP1) and differential PA (ANTP and ANTN) therefore only one current value is shown in the table below. We recommend to use the single ended PA for low output power and the differential PA for high power. The differential PA is internally multiplexed with the LNA on pins ANTP and ANTN. Therefore constraints for the RX matching have to be considered for the differential PA matching.

The current consumption can be calculated as

$$I_{TX}[mA] = \frac{1}{PA_{efficiency}} \times 10^{\frac{P_{out}[dBm] + P_{loss}[dB]}{10}} \div 1.8V + I_{offset}$$

I<sub>offset</sub> is about 6 mA for the fully integrated VCO at 400 MHz to 1050 MHz, and 3 mA for the VCO with external inductor at 169 MHz. The following table shows calculated current consumptions versus output power for P<sub>loss</sub> = 1 dB, PA<sub>efficiency</sub> = 0.5, I<sub>offset</sub> = 6 mA at 868 MHz and I<sub>offset</sub> = 3.5 mA at 169 MHz.

**Table 4. CURRENT CONSUMPTION VS. OUTPUT POWER**

| Pout [dBm] | I <sub>txcalc</sub> [mA] |         |
|------------|--------------------------|---------|
|            | 868 MHz                  | 169 MHz |
| 0          | 7.5                      | 4.5     |
| 1          | 7.9                      | 4.9     |
| 2          | 8.4                      | 5.4     |
| 3          | 9.0                      | 6.0     |
| 4          | 9.8                      | 6.8     |
| 5          | 10.8                     | 7.8     |
| 6          | 12.1                     | 9.1     |
| 7          | 13.7                     | 10.7    |
| 8          | 15.7                     | 12.7    |
| 9          | 18.2                     | 15.2    |
| 10         | 21.3                     | 18.3    |
| 11         | 25.3                     | 22.3    |
| 12         | 30.3                     | 27.3    |
| 13         | 36.7                     | 33.7    |
| 14         | 44.6                     | 41.6    |
| 15         | 54.6                     | 51.6    |

Both AX5043 power amplifiers run from the regulated VDD\_ANA supply and not directly from the battery. This has the advantage that the current and output power do not vary much over supply voltage and temperature.

**Table 5. LOGIC**

| Symbol                | Description   | Condition  | Min | Typ | Max | Units      |
|-----------------------|---|--|-----|-----|-----|------------|
| <b>Digital Inputs</b> |   |  |     |     |     |            |
| $V_{T+}$              | Schmitt trigger low to high threshold point                       |  |     | 1.9 |     | V          |
| $V_{T-}$              | Schmitt trigger high to low threshold point                       |  |     | 1.2 |     | V          |
| $V_{IL}$              | Input voltage, low  |  |     |     | 0.8 | V          |
| $V_{IH}$              | Input voltage, high   |  | 2.0 |     |     | V          |
| $I_L$                 | Input leakage current   |  | -10 |     | 10  | $\mu$ A    |
| $R_{pullup}$          | Pull-up resistors<br>Pins DATA, DCLK, SYSCLK, IRQ, PWRAMP, ANTSEL | Pull-ups enabled in the relevant pin configuration registers |     | 65  |     | k $\Omega$ |

**Digital Outputs**

|          |                                  |  |     |  |    |         |
|----------|----------------------------------|--|-----|--|----|---------|
| $I_{OH}$ | Output Current, high             | $V_{DD\_IO} = 3\text{ V}$<br>$V_{OH} = 2.4\text{ V}$ | 4   |  |    | mA      |
| $I_{OL}$ | Output Current, low              | $V_{DD\_IO} = 3\text{ V}$<br>$V_{OL} = 0.4\text{ V}$ | 4   |  |    | mA      |
| $I_{OZ}$ | Tri-state output leakage current |  | -10 |  | 10 | $\mu$ A |

**AC Characteristics**

**Table 6. CRYSTAL OSCILLATOR**

| Symbol          | Description  | Condition                 | Min   | Typ   | Max      | Units      |
|-----------------|--|---------------------------|-------|-------|----------|------------|
| $f_{XTAL}$      | Crystal frequency  | Note 1, 2, 3              | 10    | 16    | 50       | MHz        |
| $g_{m_{osc}}$   | Oscillator transconductance control range                    | Self-regulated see note 4 | 0.2   |       | 20       | mS         |
| $C_{osc}$       | Programmable tuning capacitors at pins CLK16N and CLK16P     | XTALCAP = 0x00 default    |       | 3     |          | pF         |
|                 |  | XTALCAP = 0x01            |       | 8.5   |          | pF         |
|                 |  | XTALCAP = 0xFF            |       | 40    |          | pF         |
| $C_{osc-lsb}$   | Programmable tuning capacitors, increment per LSB of XTALCAP | XTALCAP = 0x01 – 0xFF     |       | 0.5   |          | pF         |
| $f_{ext}$       | External clock input (TCXO)                                  | Note 2, 3, 5              | 10    | 16    | 50       | MHz        |
| $R_{IN_{osc}}$  | Input DC impedance   |                           | 10    |       |          | k $\Omega$ |
| $NDIV_{SYSCLK}$ | Divider ratio $f_{SYSCLK} = f_{XTAL} / NDIV_{SYSCLK}$        |                           | $2^0$ | $2^4$ | $2^{10}$ |            |

1. Tolerances and start-up times depend on the crystal used. Depending on the RF frequency and channel spacing the IC must be calibrated to the exact crystal frequency using the readings of the register TRKFREQ.
2. The choice of crystal oscillator or TCXO frequency depends on the targeted regulatory regime for TX, see separate documentation on meeting regulatory requirements.
3. To avoid spurious emission, the crystal or TCXO reference frequency should be chosen so that the RF carrier frequency is not an integer multiple of the crystal or TCXO frequency.
4. The oscillator transconductance is regulated for fastest start-up time during start-up and for lowest power during steady state oscillation. This means that values depend on the crystal used.
5. If an external clock or TCXO is used, it should be input via an AC coupling at pin CLK16P with the oscillator powered up and XTALCAP = 0x00. For detailed TCXO network recommendations depending on the TCXO output swing refer to the AX5043 Application Note: Use with a TCXO Reference Clock.

**Table 7. LOW-POWER OSCILLATOR**

| Symbol         | Description                                      | Condition   | Min | Typ  | Max  | Units |
|----------------|--|---|-----|------|------|-------|
| $f_{osc-slow}$ | Oscillator frequency slow mode<br>LPOSC FAST = 0 | No calibration  | 480 | 640  | 800  | Hz    |
|                |  | Internal calibration vs. crystal clock has been performed | 630 | 640  | 650  |       |
| $f_{osc-fast}$ | Oscillator frequency fast mode<br>LPOSC FAST = 1 | No calibration  | 7.6 | 10.2 | 12.8 | kHz   |
|                |  | Internal calibration vs. crystal clock has been performed | 9.8 | 10.2 | 10.8 |       |



**Table 8. RF FREQUENCY GENERATION SUBSYSTEM (SYNTHESIZER)**

| Symbol    | Description         | Condition   | Min | Typ | Max | Units |
|-----------|---------------------|---|-----|-----|-----|-------|
| $f_{REF}$ | Reference frequency | The reference frequency must be chosen so that the RF carrier frequency is not an integer multiple of the reference frequency | 10  | 16  | 50  | MHz   |

**Dividers**

|              |                               |  |       |  |       |  |
|--------------|-------------------------------|--|-------|--|-------|--|
| $NDIV_{ref}$ | Reference divider ratio range | Controlled directly with register REFDIV | $2^0$ |  | $2^3$ |  |
| $NDIV_m$     | Main divider ratio range      | Controlled indirectly with register FREQ | 4.5   |  | 66.5  |  |
| $NDIV_{RF}$  | RF divider range              | Controlled directly with register RFDIV  | 1     |  | 2     |  |

**Charge Pump**

|          |                     |   |     |  |      |         |
|----------|---------------------|---|-----|--|------|---------|
| $I_{CP}$ | Charge pump current | Programmable in increments of 8.5 $\mu$ A via register PLLCPI | 8.5 |  | 2168 | $\mu$ A |
|----------|---------------------|---|-----|--|------|---------|

**Internal VCO (VCOSEL = 0)**

|             |   |   |     |      |      |        |
|-------------|---|---|-----|------|------|--------|
| $f_{RF}$    | RF frequency range  | RFDIV = 1   | 400 |      | 525  | MHz    |
|             |   | RFDIV = 0   | 800 |      | 1050 |        |
| $f_{step}$  | RF frequency step   | RFDIV = 1, $f_{xtal} = 16.000000$ MHz   |     | 0.98 |      | Hz     |
| BW          | Synthesizer loop bandwidth  | The synthesizer loop bandwidth and start-up time can be programmed with registers PLLLOOP and PLLCPI.   | 50  |      | 500  | kHz    |
| $T_{start}$ | Synthesizer start-up time if crystal oscillator and reference are running | For recommendations see the AX5043 Programming Manual, the AX-RadioLab software and AX5043 Application Notes on compliance with regulatory regimes. | 5   |      | 25   |        |
| PN868       | Synthesizer phase noise 868 MHz<br>$f_{REF} = 48$ MHz                     | 10 kHz offset from carrier  |     | -95  |      | dBc/Hz |
|             |   | 1 MHz offset from carrier   |     | -120 |      |        |
| PN433       | Synthesizer phase noise 433 MHz<br>$f_{REF} = 48$ MHz                     | 10 kHz offset from carrier  |     | -105 |      | dBc/Hz |
|             |   | 1 MHz offset from carrier   |     | -120 |      |        |

**VCO with external inductors (VCOSEL = 1, VCO2INT = 1)**

|                |  |                     |    |      |     |        |
|----------------|--|---------------------|----|------|-----|--------|
| $f_{RFmg\_lo}$ | RF frequency range<br>For choice of $L_{ext}$ values as well as VCO gains see Figure 3 and Figure 4  | RFDIV = 1           | 27 |      | 262 | MHz    |
| $f_{RFmg\_hi}$ |  | RFDIV = 0           | 54 |      | 525 |        |
| PN169          | Synthesizer phase noise 169 MHz<br>$L_{ext}=47$ nH (wire wound 0603)<br>RFDIV = 0, $f_{REF}= 16$ MHz<br>Note: phase noises can be improved with higher $f_{REF}$ | 10 kHz from carrier |    | -97  |     | dBc/Hz |
|                |  | 1 MHz from carrier  |    | -115 |     |        |

**External VCO (VCOSEL = 1, VCO2INT = 0)**

|            |  |  |    |     |      |     |
|------------|--|--|----|-----|------|-----|
| $f_{RF}$   | RF frequency range fully external VCO            | Note: The external VCO frequency needs to be $2 \times f_{RF}$ | 27 |     | 1000 | MHz |
| $V_{amp}$  | Differential input amplitude at L1, L2 terminals |  |    | 0.7 |      | V   |
| $V_{inL}$  | Input voltage levels at L1, L2 terminals         |  | 0  |     | 1.8  | V   |
| $V_{ctrl}$ | Control voltage range                            | Available at FILT in external loop filter mode                 | 0  |     | 1.8  | V   |

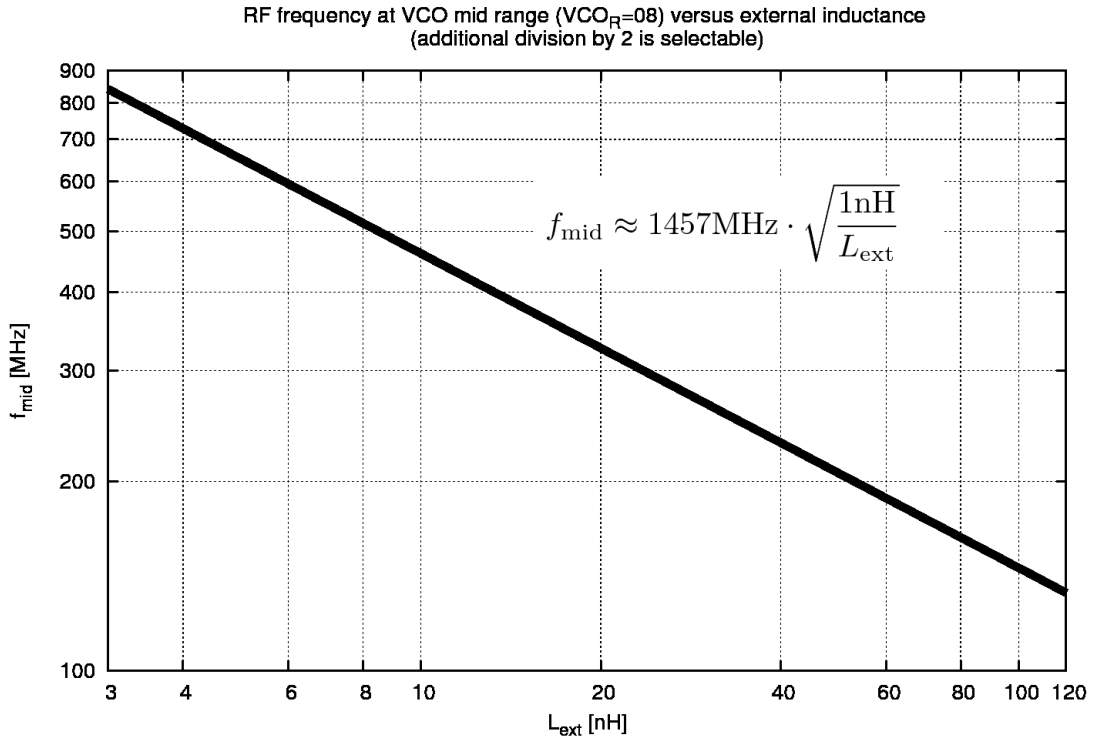

Figure 3. VCO with External Inductors: Typical Frequency vs. L<sub>ext</sub>

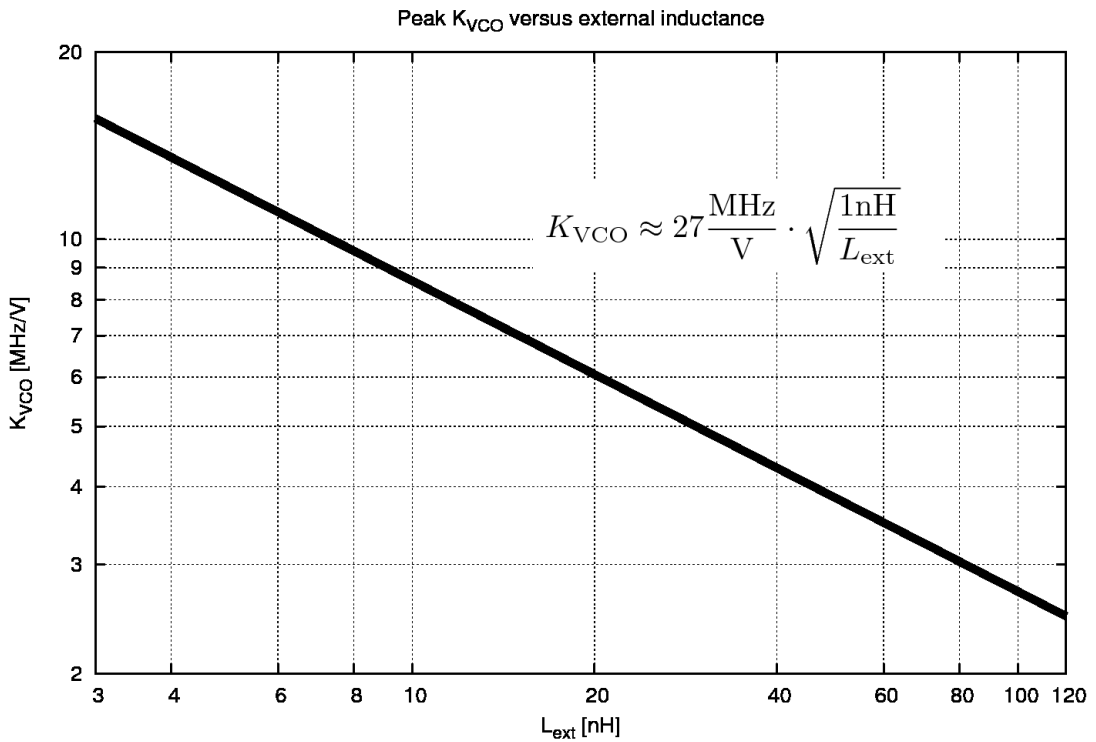

Figure 4. VCO with External Inductors: Typical K<sub>VCO</sub> vs. L<sub>ext</sub>

## AX5043

The following table shows the typical frequency ranges for frequency synthesis with external VCO inductor for different inductor values.

**Table 9.**

| <b>Lext [nH]</b> | <b>Freq [MHz]<br/>RFDIV = 0</b> | <b>Freq [MHz]<br/>RFDIV = 1</b> | <b>PLL Range</b> |
|------------------|---------------------------------|---------------------------------|------------------|
| 8.2              | 482                             | 241                             | 0                |
| 8.2              | 437                             | 219                             | 15               |
| 10               | 432                             | 216                             | 0                |
| 10               | 390                             | 195                             | 15               |
| 12               | 415                             | 208                             | 0                |
| 12               | 377                             | 189                             | 15               |
| 15               | 380                             | 190                             | 0                |
| 15               | 345                             | 173                             | 15               |
| 18               | 345                             | 173                             | 0                |
| 18               | 313                             | 157                             | 15               |
| 22               | 308                             | 154                             | 0                |
| 22               | 280                             | 140                             | 14               |
| 27               | 285                             | 143                             | 0                |
| 27               | 258                             | 129                             | 15               |

|     |     |     |    |
|-----|-----|-----|----|
| 33  | 260 | 130 | 0  |
| 33  | 235 | 118 | 15 |
| 39  | 245 | 123 | 0  |
| 39  | 223 | 112 | 14 |
| 47  | 212 | 106 | 0  |
| 47  | 194 | 97  | 14 |
| 56  | 201 | 101 | 0  |
| 56  | 182 | 91  | 15 |
| 68  | 178 | 89  | 0  |
| 68  | 161 | 81  | 15 |
| 82  | 160 | 80  | 1  |
| 82  | 146 | 73  | 14 |
| 100 | 149 | 75  | 1  |
| 100 | 136 | 68  | 14 |
| 120 | 136 | 68  | 0  |
| 120 | 124 | 62  | 14 |

For tuning or changing of ranges a capacitor can be added in parallel to the inductor.

**Table 10. TRANSMITTER**

| Symbol                   | Description  | Condition  | Min | Typ   | Max | Units |
|--------------------------|--|--|-----|-------|-----|-------|
| SBR                      | Signal bit rate  |  | 0.1 |       | 125 | kbps  |
| PTX                      | Transmitter power @ 868 MHz  | Differential PA, 50 Ω single ended measurement at an SMA connector behind the matching network, Note 2 | -10 |       | 16  | dBm   |
|                          | Transmitter power @ 433 MHz  |  | -10 |       | 16  |       |
|                          | Transmitter power @ 169 MHz  |  | -10 |       | 16  |       |
| PTX <sub>step</sub>      | Programming step size output power   | Note 1   |     |       | 0.5 | dB    |
| dTX <sub>temp</sub>      | Transmitter power variation vs. temperature  | -40°C to +85°C<br>Note 2   |     | ± 0.5 |     | dB    |
| dTX <sub>Vdd</sub>       | Transmitter power variation vs. VDD_IO   | 1.8 to 3.6 V<br>Note 2   |     | ± 0.5 |     | dB    |
| Padj                     | Adjacent channel power<br>GFSK BT = 0.5, 500 Hz deviation,<br>1.2 kbps, 25 kHz channel spacing,<br>10 kHz channel BW | 868 MHz  |     | -44   |     | dBc   |
|                          |  | 433 MHz  |     | -51   |     |       |
| PTX <sub>868-harm2</sub> | Emission @ 2 <sup>nd</sup> harmonic  | 868 MHz, Note 2  |     | -40   |     | dBc   |
| PTX <sub>868-harm3</sub> | Emission @ 3 <sup>rd</sup> harmonic  |  |     | -60   |     |       |
| PTX <sub>433-harm2</sub> | Emission @ 2 <sup>nd</sup> harmonic  | 433 MHz, Note 2  |     | -40   |     | dBc   |
| PTX <sub>433-harm3</sub> | Emission @ 3 <sup>rd</sup> harmonic  |  |     | -40   |     |       |

$$1. P_{out} = \frac{TXPWRCOEFFB}{2^{12} - 1} \times P_{max}$$

- 50 Ω single ended measurements at an SMA connector behind the matching network. For recommended matching networks see section: Application Information.

**Table 11. RECEIVER SENSITIVITIES**

The table lists typical input sensitivities (without FEC) in dBm at the SMA connector with the complete matching network for BER=10<sup>-3</sup> at 433 or 868 MHz.

| Data rate [kbps] |                    | FSK<br>h = 0.66 | FSK<br>h = 1 | FSK<br>h = 2 | FSK<br>h = 4 | FSK<br>h = 5 | FSK<br>h = 8 | FSK<br>h = 16 | PSK  |
|------------------|--------------------|-----------------|--------------|--------------|--------------|--------------|--------------|---------------|------|
| 0.1              | Sensitivity [dBm]  | -135            | -134.5       | -132.5       | -133         | -133.5       | -133         | -132.5        | -138 |
|                  | RX Bandwidth [kHz] | 0.2             | 0.2          | 0.3          | 0.5          | 0.6          | 0.9          | 2.1           | 0.2  |
|                  | Deviation [kHz]    | 0.033           | 0.05         | 0.1          | 0.2          | 0.25         | 0.4          | 0.8           |      |
| 1                | Sensitivity [dBm]  | -126            | -125         | -123         | -123.5       | -124         | -123.5       | -122.5        | -130 |
|                  | RX Bandwidth [kHz] | 1.5             | 2            | 3            | 6            | 7            | 11           | 21            | 1    |
|                  | Deviation [kHz]    | 0.33            | 0.5          | 1            | 2            | 2.5          | 4            | 8             |      |
| 10               | Sensitivity [dBm]  | -117            | -116         | -113         | -114         | -113.5       | -113         |               | -120 |
|                  | RX Bandwidth [kHz] | 15              | 20           | 30           | 50           | 60           | 110          |               | 10   |
|                  | Deviation [kHz]    | 3.3             | 5            | 10           | 20           | 25           | 40           |               |      |
| 100              | Sensitivity [dBm]  | -107            | -105.5       |              |              |              |              |               | -109 |
|                  | RX Bandwidth [kHz] | 150             | 200          |              |              |              |              |               | 100  |
|                  | Deviation [kHz]    | 33              | 50           |              |              |              |              |               |      |
| 125              | Sensitivity [dBm]  | -105            | -104         |              |              |              |              |               | -108 |
|                  | RX Bandwidth [kHz] | 187.5           | 200          |              |              |              |              |               | 125  |
|                  | Deviation [kHz]    | 42.3            | 62.5         |              |              |              |              |               |      |

- Sensitivities are equivalent for 1010 data streams and PN9 whitened data streams.
- RX bandwidths < 0.9 kHz cannot be achieved with an 48 MHz TCXO. A 16 MHz TCXO was used for all measurements at 0.1 kbps.

Table 12. RECEIVER

| Symbol                  | Description   | Condition  | Min  | Typ   | Max | Units |
|-------------------------|---|--|------|-------|-----|-------|
| SBR                     | Signal bit rate   |  | 0.1  |       | 125 | kbps  |
| IS <sub>BER868</sub>    | Input sensitivity at BER = 10 <sup>-3</sup> for 868 MHz operation, continuous data, without FEC | FSK, h = 0.5, 100 kbps   |      | -106  |     | dBm   |
|                         |   | FSK, h = 0.5, 10 kbps  |      | -116  |     |       |
|                         |   | FSK, 500 Hz deviation, 1.2 kbps  |      | -126  |     |       |
|                         |   | PSK, 100 kbps  |      | -109  |     |       |
|                         |   | PSK, 10 kbps   |      | -120  |     |       |
|                         |   | PSK, 1 kbps  |      | -130  |     |       |
| IS <sub>BER868FEC</sub> | Input sensitivity at BER = 10 <sup>-3</sup> , for 868 MHz operation, continuous data, with FEC  | FSK, h = 0.5, 50 kbps  |      | -111  |     | dBm   |
|                         |   | FSK, h = 0.5, 5 kbps   |      | -122  |     |       |
|                         |   | FSK, 500 Hz deviation, 0.1 kbps  |      | -137  |     |       |
| IS <sub>PER868</sub>    | Input sensitivity at PER = 1%, for 868 MHz operation, 144 bit packet data, without FEC          | FSK, h = 0.5, 100 kbps   |      | -103  |     | dBm   |
|                         |   | FSK, h = 0.5, 10 kbps  |      | -115  |     |       |
|                         |   | FSK, 1.2 kbps  |      | -125  |     |       |
| IS <sub>WOR868</sub>    | Input sensitivity at PER = 1% for 868 MHz operation, 144 bit packet data, WOR-mode, without FEC | FSK, h = 0.5, 100 kbps   |      | -102  |     | dBm   |
| IL                      | Maximum input level   | Full selectivity   |      | 0     |     | dBm   |
| IL <sub>max</sub>       | Maximum input level   | FSK, reduced selectivity   |      | 10    |     |       |
| CP <sub>1dB</sub>       | Input referred compression point  | 2 tones separated by 100 kHz   |      | -35   |     | dBm   |
| RSSIR                   | RSSI control range  | FSK, 500 Hz deviation, 1.2 kbps  | -126 |       | -46 | dB    |
| RSSIS <sub>1</sub>      | RSSI step size  | Before digital channel filter; calculated from register AGCCOUNTER   |      | 0.625 |     | dB    |
| RSSIS <sub>2</sub>      | RSSI step size  | Behind digital channel filter; calculated from registers AGCCOUNTER, TRKAMPL   |      | 0.1   |     | dB    |
| RSSIS <sub>3</sub>      | RSSI step size  | Behind digital channel filter; reading register RSSI   |      | 1     |     | dB    |
| SEL <sub>868</sub>      | Adjacent channel suppression  | 25 kHz channels , Note 1   |      | 45    |     | dB    |
|                         |   | 100 kHz channels, Note 1   |      | 47    |     |       |
| BLK <sub>868</sub>      | Blocking at ± 10 MHz offset   | Note 2   |      | 78    |     | dB    |
| R <sub>AFC</sub>        | AFC pull-in range   | The AFC pull-in range can be programmed with the MAXRFOFFSET registers.<br>The AFC response time can be programmed with the FREQGAIN register. | ± 15 |       |     | %     |
| R <sub>DROFF</sub>      | Bitrate offset pull-in range  | The bitrate pull-in range can be programmed with the MAXDROFFSET registers.  | ± 10 |       |     | %     |

1. Interferer/Channel @ BER = 10<sup>-3</sup>, channel level is +3 dB above the typical sensitivity, the interfering signal is CW; channel signal is modulated with shaping
2. Channel/Blocker @ BER = 10<sup>-3</sup>, channel level is +3 dB above the typical sensitivity, the blocker signal is CW; channel signal is modulated with shaping

**Table 13. RECEIVER AND TRANSMITTER SETTLING PHASES**

| Symbol                       | Description   | Condition   | Min | Typ                       | Max                  | Units |
|------------------------------|---|---|-----|---------------------------|----------------------|-------|
| T <sub>x<sub>tal</sub></sub> | XTAL settling time  | Powermodes:<br>POWERDOWN to STANDBY<br>Note that T <sub>x<sub>tal</sub></sub> depends on the specific crystal used.   |     | 0.5                       |                      | ms    |
| T <sub>synth</sub>           | Synthesizer settling time   | Powermodes:<br>STANDBY to SYNTHTX or SYNTHRX  |     | 40                        |                      | μs    |
| T <sub>tx</sub>              | TX settling time  | Powermodes:<br>SYNTHTX to FULLTX<br>T <sub>tx</sub> is the time used for power ramping, this can be programmed to be 1 x t <sub>bit</sub> , 2 x t <sub>bit</sub> , 4 x t <sub>bit</sub> or 8 x t <sub>bit</sub> .<br>Notes 1, 2 | 0   | 1 x t <sub>bit</sub>      | 8 x t <sub>bit</sub> | μs    |
| T <sub>rx_init</sub>         | RX initialization time  |   |     | 150                       |                      | μs    |
| T <sub>rx_rssi</sub>         | RX RSSI acquisition time (after T <sub>rx_init</sub> )  | Powermodes:<br>SYNTHRX to FULLRX  |     | 80 + 3 x t <sub>bit</sub> |                      | μs    |
| T <sub>rx_preamble</sub>     | RX signal acquisition time to valid data RX at full sensitivity/selectivity (after T <sub>rx_init</sub> ) | Modulation (G)FSK<br>Notes 1, 2   |     | 9 x t <sub>bit</sub>      |                      | μs    |

1. t<sub>bit</sub> depends on the datarate, e.g. for 10 kbps t<sub>bit</sub> = 100 μs
2. In wire mode there is a processing delay of typically 6 x t<sub>bit</sub> between antenna and DCLK/DATA pins

**Table 14. OVERALL STATE TRANSITION TIMES**

| Symbol               | Description   | Condition  | Min | Typ                        | Max | Units |
|----------------------|---|--|-----|----------------------------|-----|-------|
| T <sub>tx_on</sub>   | TX startup time   | Powermodes:<br>STANDBY to FULLTX<br>Notes 1, 2               | 40  | 40 + 1 x t <sub>bit</sub>  |     | μs    |
| T <sub>rx_on</sub>   | RX startup time   | Powermodes:<br>STANDBY to FULLRX                             |     | 190                        |     | μs    |
| T <sub>rx_rssi</sub> | RX startup time to valid RSSI                                 | Powermodes:<br>STANDBY to FULLRX                             |     | 270 + 3 x t <sub>bit</sub> |     | μs    |
| T <sub>rx_data</sub> | RX startup time to valid data at full sensitivity/selectivity | Modulation (G)FSK<br>Notes 1, 2                              |     | 190 + 9 x t <sub>bit</sub> |     | μs    |
| T <sub>rtx</sub>     | RX to TX switching  | Powermodes:<br>FULLRX to FULLTX                              |     | 62                         |     | μs    |
| T <sub>trx</sub>     | TX to RX switching (to preamble start)                        | Powermodes:<br>FULLTX to FULLRX                              |     | 200                        |     | μs    |
| T <sub>hop</sub>     | Frequency hop   | Switch between frequency defined in register FREQA and FREQB |     | 30                         |     | μs    |

1. t<sub>bit</sub> depends on the datarate, e.g. for 10 kbps t<sub>bit</sub> = 100 μs
2. In wire mode there is a processing delay of typically 6 x t<sub>bit</sub> between antenna and DCLK/DATA pins

**Table 15. SPI TIMING**

| Symbol | Description                         | Condition | Min | Typ | Max | Units |
|--------|-------------------------------------|-----------|-----|-----|-----|-------|
| Tss    | SEL falling edge to CLK rising edge |           | 10  |     |     | ns    |
| Tsh    | CLK falling edge to SEL rising edge |           | 10  |     |     | ns    |
| Tssd   | SEL falling edge to MISO driving    |           | 0   |     | 10  | ns    |
| Tssz   | SEL rising edge to MISO high-Z      |           | 0   |     | 10  | ns    |
| Ts     | MOSI setup time                     |           | 10  |     |     | ns    |
| Th     | MOSI hold time                      |           | 10  |     |     | ns    |
| Tco    | CLK falling edge to MISO output     |           |     |     | 10  | ns    |
| Tck    | CLK period                          | Note 1    | 50  |     |     | ns    |
| Tcl    | CLK low duration                    |           | 40  |     |     | ns    |
| Tch    | CLK high duration                   |           | 40  |     |     | ns    |

1. For SPI access during power-down mode the period should be relaxed to 100 ns

For a figure showing the SPI timing parameters see section: Serial Peripheral Interface (SPI).

**Table 16. WIRE MODE INTERFACE TIMING**

| Symbol | Description                                     | Condition                       | Min | Typ | Max    | Units |
|--------|---|---------------------------------|-----|-----|--------|-------|
| Tdck   | SEL falling edge to CLK rising edge             | Depends on bit rate programming | 1.6 |     | 10,000 | μs    |
| Tdcl   | DCLK low duration                               |                                 | 25  |     | 75     | %     |
| Tdch   | DCLK high duration                              |                                 | 25  |     | 75     | %     |
| Tds    | DATA setup time relative to active DCLK edge    |                                 | 10  |     |        | ns    |
| Tdh    | DATA hold time relative to active DCLK edge     |                                 | 10  |     |        | ns    |
| Tdco   | DATA output change relative to active DCLK edge |                                 |     |     | 10     | ns    |

For a figure showing the wire mode interface timing parameters see section: Wire Mode Interface.

**Table 17. GENERAL PURPOSE ADC (GPADC)**

| Symbol               | Description  | Condition | Min  | Typ | Max  | Units |
|----------------------|--|-----------|------|-----|------|-------|
| Res                  | Nominal ADC resolution   |           |      | 10  |      | bit   |
| F <sub>conv</sub>    | Conversion rate  |           | 0.03 |     | 1    | MS/s  |
| DR                   | Dynamic range  |           |      | 60  |      | dB    |
| INL                  | Integral nonlinearity  |           |      | ± 1 |      | LSB   |
| DNL                  | Differential nonlinearity  |           |      | ± 1 |      | LSB   |
| Z <sub>in</sub>      | Input impedance  |           |      | 50  |      | kΩ    |
| V <sub>DC-IN</sub>   | Input DC level   |           |      | 0.8 |      | V     |
| V <sub>IN-DIFF</sub> | Input signal range (differential)  |           | -500 |     | 500  | mV    |
| V <sub>IN-SE</sub>   | Input signal range (single-ended, signal input at pin GPADC1, pin GPADC2 open) |           | 300  |     | 1300 | mV    |

## CIRCUIT DESCRIPTION

The AX5043 is a true single chip ultra-low power narrow-band CMOS transceiver for use in licensed and unlicensed bands from 27 and 1050 MHz. The on-chip transceiver consists of a fully integrated RF front-end with modulator, and demodulator. Base band data processing is implemented in an advanced and flexible communication controller that enables user friendly communication via the SPI interface.

AX5043 can be operated from a 1.8 V to 3.6 V power supply over a temperature range of  $-40^{\circ}\text{C}$  to  $85^{\circ}\text{C}$ . It consumes 7 – 48 mA for transmitting at 868 MHz carrier frequency, 4 – 51 mA for transmitting at 169 MHz depending on the output power. In receive operation AX 5043 consumes 9 – 11 mA at 868 MHz carrier frequency and 6.5 – 8.5 mA at 169 MHz.

The AX5043 features make it an ideal interface for integration into various battery powered solutions such as ticketing or as transceiver for telemetric applications e.g. in sensors. As primary application, the transceiver is intended for UHF radio equipment in accordance with the European Telecommunication Standard Institute (ETSI) specification EN 300 220-1 and the US Federal Communications Commission (FCC) standard Title 47 CFR Part 15 as well as Part 90. AX5043 is compliant with respective narrow-band regulations. Additionally AX5043 is suited for systems targeting compliance with Wireless M-Bus standard EN 13757-4:2005. Wireless M-Bus frame support (S, T, R) is built-in.

AX5043 supports any data rate from 0.1 kbps to 125 kbps for FSK, 4-FSK, GFSK, GMSK, MSK, ASK and PSK. To achieve optimum performance for specific data rates and modulation schemes several register settings to configure the AX5043 are necessary, for details see the AXSEM RadioLab Software which calculates the necessary register settings and the AX5043 Programming Manual.

The AX5043 can be operated in two fundamentally different modes.

In **frame mode** data is sent and received via the SPI port in frames. Pre- and post-ambles as well as checksums can be generated automatically. Interrupts control the data flow between a micro-controller and the AX5043.

In **wire mode** the IC behaves as an extension of any wire. The internal communication controller is disabled and the modem data is directly available on a dedicated pin (DATA). The bit clock is also output on a dedicated pin (DCLK). In this mode the user can connect the data pin to any port of a micro-controller or to a UART, but has to control coding, checksums, pre and post ambles. The user can choose between synchronous and asynchronous wire mode, asynchronous wire mode performs RS232 start bit recognition and re-synchronization for transmit.

Both modes can be used both for transmit and receive. In both cases the AX5043 behaves as a SPI slave interface. Configuration of the AX5043 is always done via the SPI interface.

The receiver and the transmitter support multi-channel operation for all data rates and modulation schemes.

### Voltage Regulators

The AX5043 uses an on-chip voltage regulator system to create stable supply voltages for the internal circuitry from the primary supply VDD\_IO. The I/O level of the digital pins is VDD\_IO.

Pins VDD\_ANA are supplied for external decoupling of the power supply used for the on-chip PA.

The voltage regulator system must be set into the appropriate state before receive or transmit operations can be initiated. This is handled automatically when programming the device modes via the PWRMODE register.

Register POWSTAT contains status bits that can be read to check if the regulated voltages are ready (bit SVIO) or if VDD\_IO has dropped below the brown-out level of 1.3V (bit SSUM).

In power-down mode the core supply voltages for digital and analog functions are switched off to minimize leakage power. Most register contents are preserved but access to the FIFO is not possible and FIFO contents are lost. SPI access to registers is possible, but at lower speed.

In deep-sleep mode all supply voltages are switched off. All digital and analog functions are disabled. All register contents are lost. To leave deep-sleep mode the pin SEL has to be pulled low. This will initiate startup and reset of the AX5043. Then the MISO line should be polled, as it will be held low during initialization and will rise to high at the end of the initialization, when the chip becomes ready for operation.

### Crystal Oscillator and TCXO Interface

The AX5043 is normally operated with an external TCXO, which is required by most narrow-band regulation with a tolerance of 0.5 ppm to 1.5 ppm depending on the regulation. The on-chip crystal oscillator allows the use of an inexpensive quartz crystal as the RF generation subsystem's timing reference when possible from a regulatory point of view.

A wide range of crystal frequencies can be handled by the crystal oscillator circuit. As the reference frequency impacts both the spectral performance of the transmitter as well as the current consumption of the receiver, the choice of reference frequency should be made according to the regulatory regime targeted by the application. For guidelines see the separate Application Notes for usage of AX5043 in compliance with various regulatory regimes.

The crystal or TCXO reference frequency should be chosen so that the RF carrier frequency is not an integer multiple of the crystal or TCXO frequency.

The oscillator circuit is enabled by programming the PWRMODE register. At power-up it is enabled.



To adjust the circuit's characteristics to the quartz crystal being used, without using additional external components, the tuning capacitance of the crystal oscillator can be programmed. The transconductance of the oscillator is automatically regulated, to allow for fastest start-up times together with lowest power operation during steady-state oscillation.

The integrated programmable tuning capacitor bank makes it possible to connect the oscillator directly to pins CLK16N and CLK16P without the need for external capacitors. It is programmed using bits XTALCAP[5:0] in register XTALCAP.

To synchronize the receiver frequency to a carrier signal, the oscillator frequency could be tuned using the capacitor bank however, the recommended method to implement frequency synchronization is to make use of the high resolution RF frequency generation sub-system together with the Automatic Frequency Control, both are described further down.

Alternatively a single ended reference (TXCO, CXO) may be used. For detailed TCXO network recommendations depending on TCXO output swing refer to the AX5043 Application Note: Use with a TCXO Reference Clock.

**Low Power Oscillator and Wake-on-Radio (WOR) Mode**

The AX5043 features an internal lowest power fully integrated oscillator. In default mode the frequency of

oscillation is 640 Hz ± 1.5%, in fast mode it is 10.2 kHz ± 1.5%. These accuracies are reached after the internal hardware has been used to calibrate the low power oscillator versus the RF reference clock. This procedure can be run in the background during transmit or receive operations.

The low power oscillator makes a WOR mode with a power consumption of 500 nA possible.

If Wake on Radio Mode is enabled, the receiver wakes up periodically at a user selectable interval, and checks for a radio signal on the selected channel. If no signal is detected, the receiver shuts down again. If a radio signal is detected, and a valid packet is received, the microcontroller is alerted by asserting an interrupt.

The AX5043 can thus autonomously poll for radio signals, while the micro-controller can stay powered down, and only wakes up once a valid packet is received. This allows for very low average receiver power, at the expense of longer preambles at the transmitter.

**GPIO Pins**

Pins DATA, DCLK, SYSCLK, IRQ, ANTSEL, PWRAMP can be used as general purpose I/O pins by programming pin configuration registers PINFUNCSYSCLK, PINFUNCDCLK, PINFUNCDATA, PINFUNCIRQ, PINFUNCNANTSEL, PINFUNCPWRAMP. Pin input values can be read via register PINSTATE. Pull-ups are disabled if output data is programmed to the GPIO pin.

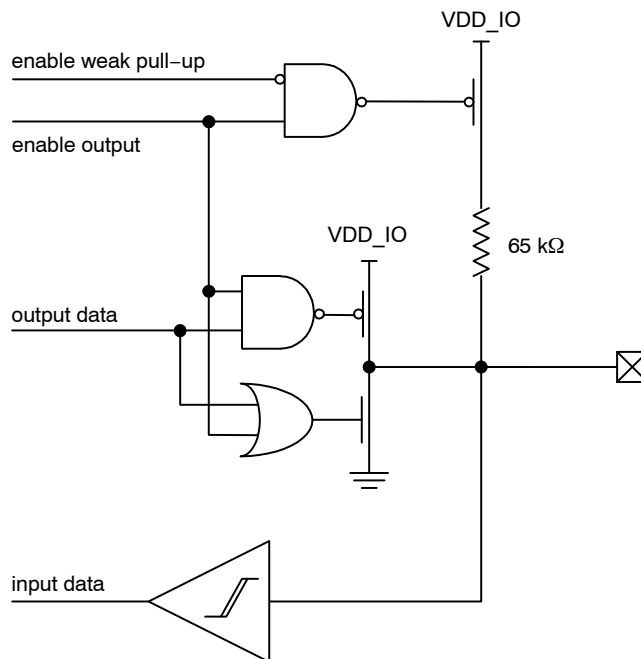

Figure 5. GPIO Pin

### SYCLK Output

The SYCLK pin outputs either the reference clock signal divided by a programmable power of two or the low power oscillator clock. Division ratios from 1 to 1024 are possible. For divider ratios > 1 the duty cycle is 50%. Bits SYCLK[4:0] in the PINFUNCSYCLK register set the divider ratio. The SYCLK output can be disabled.

After power-up SYCLK outputs 1/16 of the crystal oscillator clock, making it possible to use this clock to boot a micro-controller.

### Power-on-Reset (POR)

AX5043 has an integrated power-on-reset block. No external POR circuit is required.

After POR the AX5043 can be reset by first setting the SPI SEL pin to high for at least 100 ns, then setting followed by resetting the bit RST in the PWRMODE register.

After POR or reset all registers are set to their default values.

### RF Frequency Generation Subsystem

The RF frequency generation subsystem consists of a fully integrated synthesizer, which multiplies the reference frequency from the crystal oscillator to get the desired RF frequency. The advanced architecture of the synthesizer enables frequency resolutions of 1 Hz, as well as fast settling times of 5 – 50  $\mu$ s depending on the settings (see section AC Characteristics). Fast settling times mean fast start-up and fast RX/TX switching, which enables low-power system design.

For receive operation the RF frequency is fed to the mixer, for transmit operation to the power-amplifier.

The frequency must be programmed to the desired carrier frequency.

The synthesizer loop bandwidth can be programmed, this serves three purposes:

1. Start-up time optimization, start-up is faster for higher synthesizer loop bandwidths
2. TX spectrum optimization, phase-noise at 300 kHz to 1 MHz distance from the carrier improves with lower synthesizer loop bandwidths
3. Adaptation of the bandwidth to the data-rate. For transmission of FSK and MSK it is required that the synthesizer bandwidth must be in the order of the data-rate.

### VCO

An on-chip VCO converts the control voltage generated by the charge pump and loop filter into an output frequency. This frequency is used for transmit as well as for receive operation. The frequency can be programmed in 1 Hz steps in the FREQ registers. For operation in the 433 MHz band, the RFDIV bit in the PLLVCODIV register must be programmed.

The fully integrated VCO allows to operate the device in the frequency ranges 800 – 1050 MHz and 400 – 525 MHz.

The carrier frequency range can be extended to 54 – 525 MHz and 27 – 262 MHz by using an appropriate external inductor between device pins L1 and L2. The bit VCO2INT in the PLLVCODIV register must be set high to enter this mode.

It is also possible to use a fully external VCO by setting bits VCO2INT = 0 and VCOSEL = 1 in the PLLVCODIV register. A differential input at a frequency of double the desired RF frequency must be input at device pins L1 and L2. The control voltage for the VCO can be output at device pin FILT when using external filter mode. The voltage range of this output pin is 0 – 1.8 V.

This mode of operation is recommended for special applications where the phase noise requirements are not met when using the fully internal VCO or the internal VCO with external inductor.

### VCO Auto-Ranging

The AX5043 has an integrated auto-ranging function, which allows to set the correct VCO range for specific frequency generation subsystem settings automatically. Typically it has to be executed after power-up. The function is initiated by setting the RNG\_START bit in the PLLRANGINGA or PLLRANGINGB register. The bit is readable and a 0 indicates the end of the ranging process. Setting RNG\_START in the PLLRANGINGA register ranges the frequency in FREQA, while setting RNG\_START in the PLLRANGINGB register ranges the frequency in FREQB. The RNGERR bit indicates the correct execution of the auto-ranging.

VCO auto-ranging works with the fully integrated VCO and with the internal VCO with external inductor.

### Loop Filter and Charge Pump

The AX5043 internal loop filter configuration together with the charge pump current sets the synthesizer loop bandwidth. The internal loop-filter has three configurations that can be programmed via the register bits FLT[1:0] in registers PLLLOOP or PLLLOOPBOOST the charge pump current can be programmed using register bits PLLCPI[7:0] in registers PLLCPI or PLLCPIBOOST. Synthesizer bandwidths are typically 50 – 500 kHz depending on the PLLLOOP or PLLLOOPBOOST settings, for details see the section: AC Characteristics.

The AX5043 can be setup in such a way that when the synthesizer is started, the settings in the registers PLLLOOPBOOST and PLLCPIBOOST are applied first for a programmable duration before reverting to the settings in PLLLOOP and PLLCPI. This feature enables automated fastest start-up.

Setting bits FLT[1:0] = 00 bypasses the internal loop filter and the VCO control voltage is output to an external loop filter at pin FILT. This mode of operation is recommended for achieving lower bandwidths than with the internal loop filter and for usage with a fully external VCO.

Table 18. RF FREQUENCY GENERATION REGISTERS

| Register                 | Bits     | Purpose   |
|--------------------------|----------|---|
| PLLLOOP<br>PLLLOOPBOOST  | FLT[1:0] | Synthesizer loop filter bandwidth and selection of external loop filter, recommended usage is to increase the bandwidth for faster settling time, bandwidth increases of factor 2 and 5 are possible. |
| PLLCPI<br>PLLCPIBOOST    |          | Synthesizer charge pump current, recommended usage is to decrease the bandwidth (and improve the phase-noise) for low data-rate transmissions.  |
| PLLVCODIV                | REFDIV   | Sets the synthesizer reference divider ratio.   |
|                          | RFDIV    | Sets the synthesizer output divider ratio.  |
|                          | VCOSEL   | Selects either the internal or the external VCO   |
|                          | VCO2INT  | Selects either the internal VCO inductor or an external inductor between pins L1 and L2   |
| FREQA, FREQB             |          | Programming of the carrier frequency  |
| PLLRANGINGA, PLLRANGINGB |          | Initiate VCO auto-ranging and check results   |

### RF Input and Output Stage (ANTP/ANTN/ANTP1)

The AX5043 has two main antenna interface modes:

- Both RX and TX use differential pins ANTP and ANTN. RX/TX switching is handled internally. This mode is recommended for highest output powers, highest sensitivities and for direct connection to dipole antennas. Also see Figure 13.
- RX uses the differential antenna pins ANTP and ANTN. TX uses the single ended antenna pin ANTP1. RX/TX switching is handled externally. This can be done either with an external RX/TX switch or with a direct tie configuration. This mode is recommended for low output powers at high efficiency (Figure 16) and for usage with external power amplifiers (Figure 15).

Pin PWRAMP can be used to control an external RX/TX switch when operating the device together with an external PA (Figure 15). Pin ANTSEL can be used to control an external antenna switch when receiving with two antennas (Figure 17).

When antenna diversity is enabled, the radio controller will, when not in the middle of receiving a packet, periodically probe both antennas and select the antenna with the highest signal strength. The radio controller can be instructed to periodically write both RSSI values into the FIFO. Antenna diversity mode is fully automatic.

### LNA

The LNA amplifies the differential RF signal from the antenna and buffers it to drive the I/Q mixer. An external matching network is used to adapt the antenna impedance to the IC impedance. A DC feed to GND must be provided at the antenna pins. For recommendations see section: Application Information.

### PA

In TX mode the PA drives the signal generated by the frequency generation subsystem out to either the differential antenna terminals or to the single ended antenna pin. The antenna terminals are chosen via the bits TXDIFF and TXSE in register MODECFGA.

The output power of the PA is programmed via the register TXPWRCOEFFB.

The PA can be digitally pre-distorted for high linearity.

The output amplitude can be shaped (raised cosine), this mode is selected with bit AMPLSHAPE in register MODECFGA. PA ramping is programmable in increments of the bit time and can be set to 1 – 8 bit times via bits SLOWRAMP in register MODECFGA.

Output power as well as harmonic content will depend on the external impedance seen by the PA, recommendations are given in the section: Application Information.

### Digital IF Channel Filter and Demodulator

The digital IF channel filter and the demodulator extract the data bit-stream from the incoming IF signal. They must be programmed to match the modulation scheme as well as the data-rate. Inaccurate programming will lead to loss of sensitivity.

The channel filter offers bandwidths of 995 Hz up to 221 kHz.

The AXSEM RadioLab Software calculates the necessary register settings for optimal performance and details can be found in the AX5043 Programming Manual. An overview of the registers involved is given in the following table as reference. The register setups typically must be done once at power-up of the device.

**Table 19. CHANNEL FILTER AND DEMODULATOR REGISTERS**

| Register   | Remarks  |
|--|--|
| DECIMATION   | This register programs the bandwidth of the digital channel filter.  |
| RXDATARATE2... RXDATARATE0                                       | These registers specify the receiver bit rate, relative to the channel filter bandwidth.   |
| MAXDROFFSET2... MAXDROFFSET0                                     | These registers specify the maximum possible data rate offset.   |
| MAXRFOFFSET2... MAXRFOFFSET0                                     | These registers specify the maximum possible RF frequency offset.  |
| TIMEGAIN, DRGAIN   | These registers specify the aggressiveness of the receiver bit timing recovery. More aggressive settings allow the receiver to synchronize with shorter preambles, at the expense of more timing jitter and thus a higher bit error rate at a given signal-to-noise ratio. |
| MODULATION   | This register selects the modulation to be used by the transmitter and the receiver, i.e. whether ASK, FSK should be used.   |
| PHASEGAIN, FREQGAINA, FREQGAINB, FRE-QGAINC, FREQGAIND, AMPLGAIN | These registers control the bandwidth of the phase, frequency offset and amplitude tracking loops.   |
| AGCGAIN  | This register controls the AGC (automatic gain control) loop slopes, and thus the speed of gain adjustments. The faster the bit-rate, the faster the AGC loop should be.   |
| TXRATE   | These registers control the bit rate of the transmitter.   |
| FSKDEV   | These registers control the frequency deviation of the transmitter in FSK mode. The receiver does not explicitly need to know the frequency deviation, only the channel filter bandwidth has to be set wide enough for the complete modulation to pass.                    |

**Encoder**

The encoder is located between the Framing Unit, the Demodulator and the Modulator. It can optionally transform the bit-stream in the following ways:

- It can invert the bit stream.
- It can perform differential encoding. This means that a zero is transmitted as no change in the level, and a one is transmitted as a change in the level.
- It can perform Manchester encoding. Manchester encoding ensures that the modulation has no DC content and enough transitions (changes from 0 to 1 and from 1 to 0) for the demodulator bit timing recovery to function correctly, but does so at a doubling of the data rate.
- It can perform spectral shaping (also known as whitening). Spectral shaping removes DC content of the bit stream, ensures transitions for the demodulator bit timing recovery, and makes sure that the transmitted spectrum does not have discrete lines even if the transmitted data is cyclic. It does so without adding additional bits, i.e. without changing the data rate. Spectral Shaping uses a self synchronizing feedback shift register.

The encoder is programmed using the register ENCODING, details and recommendations on usage are given in the AX5043 Programming Manual.

**Framing and FIFO**

Most radio systems today group data into packets. The framing unit is responsible for converting these packets into

a bit-stream suitable for the modulator, and to extract packets from the continuous bit-stream arriving from the demodulator.

The Framing unit supports two different modes:

- Packet modes
- Raw modes

The micro-controller communicates with the framing unit through a 256 byte FIFO. Data in the FIFO is organized in Chunks. The chunk header encodes the length and what data is contained in the payload. Chunks may contain packet data, but also RSSI, Frequency offset, Timestamps, etc.

The AX5043 contains one FIFO. Its direction is switched depending on whether transmit or receive mode is selected.

The FIFO can be operated in polled or interrupt driven modes. In polled mode, the microcontroller must periodically read the FIFO status register or the FIFO count register to determine whether the FIFO needs servicing.

In interrupt mode EMPTY, NOT EMPTY, FULL, NOT FULL and programmable level interrupts are provided. The AX5043 signals interrupts by asserting (driving high) its IRQ line. The interrupt line is level triggered, active high. Interrupts are acknowledged by removing the cause for the interrupt, i.e. by emptying or filling the FIFO.

Basic FIFO status (EMPTY, FULL, Overrun, Underrun, FIFO fill level above threshold, FIFO free space above threshold) are also provided during each SPI access on MISO while the micro-controller shifts out the register address on MOSI. See the SPI interface section for details. This feature significantly reduces the number of SPI accesses necessary during transmit and receive.

## AX5043

### Packet Modes

The AX5043 offers different packet modes. For arbitrary packet sizes HDLC is recommended since the flag and bit-stuffing mechanism. The AX5043 also offers packet modes with fixed packet length with a byte indicating the length of the packet.

In packet modes a CRC can be computed automatically.

HDLC Mode is the main framing mode of the AX5043. In this mode, the AX5043 performs automatic packet

delimiting, and optional packet correctness check by inserting and checking a cyclic redundancy check (CRC) field.

NOTE: HDLC mode follows High-Level Data Link Control (HDLC, ISO 13239) protocol.

The packet structure is given in the following table.

**Table 20. HDLC PACKET STRUCTURE**

| Flag  | Address | Control     | Information                                       | FCS         | (Optional Flag) |
|-------|---------|-------------|---|-------------|-----------------|
| 8 bit | 8 bit   | 8 or 16 bit | Variable length, 0 or more bits in multiples of 8 | 16 / 32 bit | 8 bit           |

HDLC packets are delimited with flag sequences of content 0x7E.

In AX5043 the meaning of address and control is user defined. The Frame Check Sequence (FCS) can be programmed to be CRC-CCITT, CRC-16 or CRC-32.

The receiver checks the CRC, the result can be retrieved from the FIFO, the CRC is appended to the received data.

In Wireless M-Bus Mode, the packet structure is given in the following table.

NOTE: Wireless M-Bus mode follows EN13757-4

**Table 21. WIRELESS M-BUS PACKET STRUCTURE**

| Preamble | L     | C     | M      | A      | FCS    | Optional Data Block<br>(optionally repeated with FCS) | FCS    |
|----------|-------|-------|--------|--------|--------|---|--------|
| variable | 8 bit | 8 bit | 16 bit | 48 bit | 16 bit | 8 – 96 bit  | 16 bit |

For details on implementing a HDLC communication as well as Wireless M-Bus please use the AXSEM RadioLab software and see the AX5043 Programming Manual.

### Raw Modes

In Raw mode, the AX5043 does not perform any packet delimiting or byte synchronization. It simply serializes transmit bytes and de-serializes the received bit-stream and groups it into bytes. This mode is ideal for implementing legacy protocols in software.

Raw mode with preamble match is similar to raw mode. In this mode, however, the receiver does not receive anything until it detects a user programmable bit pattern (called the preamble) in the receive bit-stream. When it detects the preamble, it aligns the de-serialization to it.

The preamble can be between 4 and 32 bits long.

### RX AGC and RSSI

AX5043 features three receiver signal strength indicators (RSSI):

1. RSSI before the digital IF channel filter.

The gain of the receiver is adjusted in order to keep the analog IF filter output level inside the working range of the ADC and demodulator. The register AGCCOUNTER contains the current

value of the AGC and can be used as an RSSI. The step size of this RSSI is 0.625 dB. The value can be used as soon as the RF frequency generation sub-system has been programmed.

2. RSSI behind the digital IF channel filter.

The register RSSI contains the current value of the RSSI behind the digital IF channel filter. The step size of this RSSI is 1 dB.

3. RSSI behind the digital IF channel filter high accuracy.

The demodulator also provides amplitude information in the TRK\_AMPLITUDE register. By combining both the AGCCOUNTER and the TRK\_AMPLITUDE registers, a high resolution (better than 0.1 dB) RSSI value can be computed at the expense of a few arithmetic operations on the micro-controller. The AXSEM RadioLab Software calculates the necessary register settings for best performance and details can be found in the AX5043 Programming Manual.

### Modulator

Depending on the transmitter settings the modulator generates various inputs for the PA:

**Table 22. MODULATIONS**

| Modulation        | Bit = 0                            | Bit = 1                            | Main Lobe Bandwidth                 | Max. Bitrate |
|-------------------|------------------------------------|------------------------------------|-------------------------------------|--------------|
| ASK               | PA off                             | PA on                              | BW = BITRATE                        | 125 kBit/s   |
| FSK/MSK/GFSK/GMSK | $\Delta f = -f_{\text{deviation}}$ | $\Delta f = +f_{\text{deviation}}$ | $BW = (1 + h) \cdot \text{BITRATE}$ | 125 kBit/s   |
| PSK               | $\Delta\Phi = 0^\circ$             | $\Delta\Phi = 180^\circ$           | BW = BITRATE                        | 125 kBit/s   |

$h$  = modulation index. It is the ratio of the deviation compared to the bit-rate;  $f_{\text{deviation}} = 0.5 \cdot h \cdot \text{BITRATE}$ , AX5043 can demodulate signals with  $h < 32$ .

ASK = amplitude shift keying

FSK = frequency shift keying

MSK= minimum shift keying; MSK is a special case of FSK, where  $h = 0.5$ , and therefore

$f_{\text{deviation}} = 0.25 \cdot \text{BITRATE}$ ; the advantage of MSK over FSK is that it can be demodulated more robustly.

PSK = phase shift keying

All modulation schemes, except 4-FSK, are binary.

Amplitude can be shaped using a raised cosine waveform. Amplitude shaping will also be performed for constant amplitude modulation ((G)FSK, (G)MSK) for ramping up and down the PA. Amplitude shaping should always be enabled.

Frequency shaping can either be hard (FSK, MSK), or Gaussian (GMSK, GFSK), with selectable BT = 0.3 or BT = 0.5.

**Table 23. 4-FSK MODULATION**

| Modulation | DiBit = 00                          | DiBit = 01                         | DiBit = 11                         | DiBit = 10                          | Main Lobe Bandwidth                  | Max. Bitrate |
|------------|-------------------------------------|------------------------------------|------------------------------------|-------------------------------------|--------------------------------------|--------------|
| 4-FSK      | $\Delta f = -3f_{\text{deviation}}$ | $\Delta f = -f_{\text{deviation}}$ | $\Delta f = +f_{\text{deviation}}$ | $\Delta f = +3f_{\text{deviation}}$ | $BW = (1 + 3h) \cdot \text{BITRATE}$ | 125 kBit/s   |

4-FSK Frequency shaping is always hard.

$$\Delta f = \frac{\text{TRKRFFREQ}}{2^{24}} f_{\text{XTAL}}$$

**Automatic Frequency Control (AFC)**

The AX5043 features an automatic frequency tracking loop which is capable of tracking the transmitter frequency within the RX filter band width. On top of that the AX5043 has a frequency tracking register TRKRFFREQ to synchronize the receiver frequency to a carrier signal. For AFC adjustment, the frequency offset can be computed with the following formula:

The pull-in range of the AFC can be programmed with the MAXRFOFFSET Registers.

**PWRMODE Register**

The PWRMODE register controls, which parts of the chip are operating.

**Table 24. PWRMODE REGISTER**

| PWRMODE Register | Name      | Description  |
|------------------|-----------|--|
| 0000             | POWERDOWN | All digital and analog functions, except the register file, are disabled. The core supply voltages are switched off to conserve leakage power. Register contents are preserved and accessible registers via SPI, but at a slower speed.<br>Access to the FIFO is not possible and the contents are not preserved. POWERDOWN mode is only entered once the FIFO is empty.   |
| 0001             | DEEPSLEEP | AX5043 is fully turned off. All digital and analog functions are disabled. All register contents are lost.<br>To leave DEEPSLEEP mode the pin SEL has to be pulled low. This will initiate startup and reset of the AX5043. Then the MISO line should be polled, as it will be held low during initialization and will rise to high at the end of the initialization, when the chip becomes ready for operation. |
| 0101             | STANDBY   | The crystal oscillator and the reference are powered on; receiver and transmitter are off. Register contents are preserved and accessible registers via SPI.<br>Access to the FIFO is not possible and the contents are not preserved. STANDBY is only entered once the FIFO is empty.   |
| 0110             | FIFO      | The reference is powered on. Register contents are preserved and accessible registers via SPI.<br>Access to the FIFO is possible and the contents are preserved.   |
| 1000             | SYNTHRX   | The synthesizer is running on the receive frequency. Transmitter and receiver are still off. This mode is used to let the synthesizer settle on the correct frequency for receive.   |
| 1001             | FULLRX    | Synthesizer and receiver are running.  |

**Table 24. PWRMODE REGISTER**

| PWRMODE Register | Name    | Description  |
|------------------|---------|--|
| 1011             | WOR     | Receiver wakeup-on-radio mode. The mode the same as POWERDOWN, but the 640 Hz internal low power oscillator is running.  |
| 1100             | SYNTHTX | The synthesizer is running on the transmit frequency. Transmitter and receiver are still off. This mode is used to let the synthesizer settle on the correct frequency for transmit.                                   |
| 1101             | FULLTX  | Synthesizer and transmitter are running. Do not switch into this mode before the synthesizer has completely settled on the transmit frequency (in SYNTHTX mode), otherwise spurious spectral transmissions will occur. |

**Table 25. A TYPICAL PWRMODE SEQUENCE FOR A TRANSMIT SESSION**

| Step | PWRMODE   | Remarks  |
|------|-----------|--|
| 1    | POWERDOWN |  |
| 2    | STANDBY   | The settling time is dominated by the crystal used, typical value 3ms. |
| 3    | FULLTX    | Data transmission  |
| 4    | POWERDOWN |  |

**Table 26. A TYPICAL PWRMODE SEQUENCE FOR A RECEIVE SESSION**

| Step | PWRMODE [3:0] | Remarks  |
|------|---------------|--|
| 1    | POWERDOWN     |  |
| 2    | STANDBY       | The settling time is dominated by the crystal used, typical value 3ms. |
| 3    | FULLRX        | Data reception   |
| 4    | POWERDOWN     |  |

**Serial Peripheral Interface**

The AX5043 can be programmed via a four wire serial interface according SPI using the pins CLK, MOSI, MISO and SEL. Registers for setting up the AX5043 are programmed via the serial peripheral interface in all device modes.

When the interface signal SEL is pulled low, a configuration data stream is expected on the input signal pin MOSI, which is interpreted as D0...Dx, A0...Ax, R\_N/W. Data read from the interface appears on MISO.

Figure 6 shows a write/read access to the interface. The data stream is built of an address byte including read/write information and a data byte. Depending on the R\_N/W bit and address bits A[6..0], data D[7..0] can be written via MOSI or read at the pin MISO. R\_N/W = 0 means read mode, R\_N/W = 1 means write mode.

Most registers are 8 bits wide and accessed using the waveforms as detailed in Figure 7. The most important

registers are at the beginning of the address space, i.e. at addresses less than 0x70. These registers can be accessed more efficiently using the short address form, which is detailed in Figure 6.

Some registers are longer than 8 bits. These registers can be accessed more quickly than by reading and writing individual 8 bit parts. This is illustrated in Figure 8. Accesses are not limited by 16 bits either, reading and writing data bytes can be continued as long as desired. After each byte, the address counter is incremented by one. Also, this access form works with long addresses.

During the address phase of the access, the AX5043 outputs the most important status bits. This feature is designed to speed up the software decision on what to do in an interrupt handler.

The status bits contain the following information:

**Table 27. SPI STATUS BITS**

| SPI Bit Cell | Status | Meaning / Register Bit  |
|--------------|--------|---|
| 0            | -      | 1 (when transitioning out of deep sleep mode, this bit transitions from 0 → 1 when the power becomes ready) |
| 1            | S14    | PLL LOCK  |
| 2            | S13    | FIFO OVER   |

Table 27. SPI STATUS BITS

| SPI Bit Cell | Status | Meaning / Register Bit                   |
|--------------|--------|--|
| 3            | S12    | FIFO UNDER                               |
| 4            | S11    | THRESHOLD FREE (FIFOFREE > FIFOTHRESH)   |
| 5            | S10    | THRESHOLD COUNT (FIFOCOUNT > FIFOTHRESH) |
| 6            | S9     | FIFO FULL                                |
| 7            | S8     | FIFO EMPTY                               |
| 8            | S7     | PWRGOOD (not BROWNOUT)                   |
| 9            | S6     | PWR INTERRUPT PENDING                    |
| 10           | S5     | RADIO EVENT PENDING                      |
| 11           | S4     | XTAL OSCILLATOR RUNNING                  |
| 12           | S3     | WAKEUP INTERRUPT PENDING                 |
| 13           | S2     | LPOSC INTERRUPT PENDING                  |
| 14           | S1     | GPADC INTERRUPT PENDING                  |
| 15           | S0     | internal                                 |

NOTE: Device will meet the specifications after thermal equilibrium has been established when mounted in a test socket or printed circuit board with maintained transverse airflow greater than 500 lpm.

SPI Timing

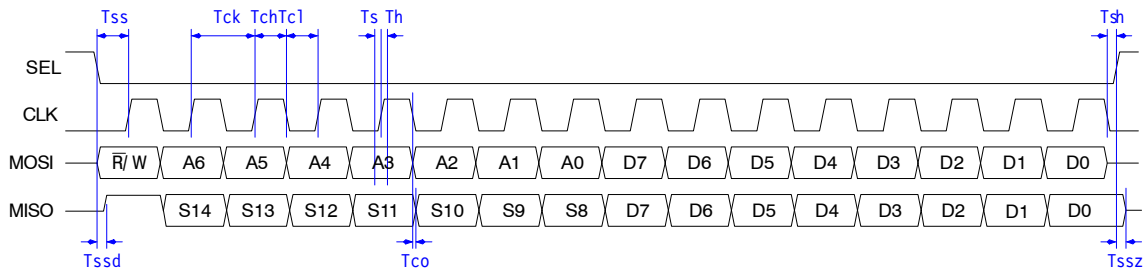

Figure 6. SPI 8 Bit Read/Write Access with Timing

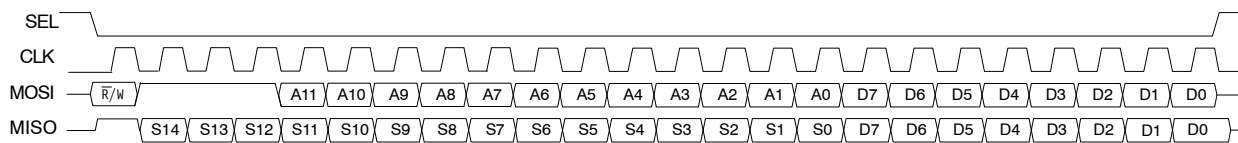

Figure 7. SPI 8 Bit Long Address Read/Write Access

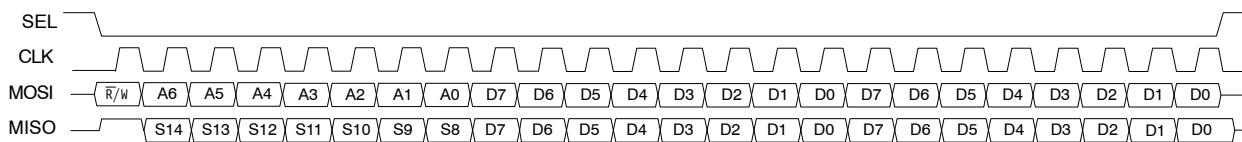

Figure 8. SPI 16 Bit Long Read/Write Access

Wire Mode Interface

In wire mode the transmitted or received data are transferred from and to the AX5043 using the pins DATA and DCLK. DATA is an input when transmitting and an output when receiving.

The direction can be chosen by programming the PWRMODE register.

Wire mode offers two variants: synchronous or asynchronous.



## AX5043

In synchronous wire mode the, the AX5043 always drives DCLK. Transmit data must be applied to DATA synchronously to DCLK, and receive data must be sampled synchronously to DCLK. Timing is given in Figure 9. In asynchronous wire mode, a low voltage RS232 type UART can be connected to DATA. DCLK is optional in this mode. The UART must be programmed to send two stop bits, but must be able to accept only one stop bit. Both the UART data rate and the AX5043 transmit and receive bit rate must match. The AX5043 synchronizes the RS232 signal to its internal transmission clock, by inserting or deleting a stop bit.

Wiremode is also available in 4-FSK mode. The two bits that encode one symbol are serialized on the DATA pin. The PWRAMP pin can be used as a synchronisation pin to allow symbol (dibit) boundaries to be reconstructed. Gray coding is used to reduce the number of bit errors in case of a wrong decision. The AXSEM RadioLab software calculates the necessary register settings for best performance and details can be found in the AX5043 Programming Manual.

Registers for setting up the AX5043 are programmed via the serial peripheral interface (SPI).

### Wire Mode Timing

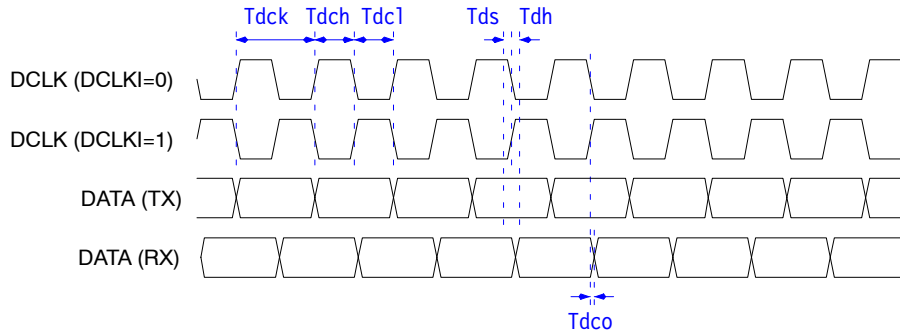

Figure 9. Wire Mode Interface Timing

### General Purpose ADC (GPADC)

The AX5043 features a general purpose ADC. The ADC input pins are GPADC1 and GPADC2. The ADC converts the voltage difference applied between pins GPADC1 and GPADC2. If pin GPADC2 is left open, the ADC converts the difference between an internally generated value of 800 mV and the voltage applied at pin GPADC1.

The GPADC can only be used if the receiver is disabled. To enable the GPADC write 1 to the GPADC13 bit in the GPADCCTRL register. To start a single conversion, write 1 to the BUSY bit in the GPADCCTRL register. Then wait for the BUSY bit to clear, or the GPADC Interrupt to be asserted.

The GPADC Interrupt is cleared by reading the result register GPADC13VALUE.

If continuous sampling is desired, set the CONT bit in register GPADCCTRL. The desired sampling rate can be specified in the GPADCPERIOD register.

### $\Sigma\Delta$ DAC

One digital Pin (ANTSEL or PWRAMP) may be used as a  $\Sigma\Delta$  Digital-to-Analog Converter. A simple RC lowpass filter is needed to smooth the output. The DAC may be used to output RSSI, many demodulator variables, or a constant value under software control.

**REGISTER BANK DESCRIPTION**

This section describes the bits of the register bank as reference. The registers are grouped by functional block to facilitate programming. The AXSEM RadioLab software calculates the necessary register settings for best performance and details can be found in the AX5043 Programming Manual.

An R in the retention column means that this register's contents are not lost during power-down mode.

No checks are made whether the programmed combination of bits makes sense! Bit 0 is always the LSB.

NOTES: Whole registers or register bits marked as reserved should be kept at their default values.

All addresses not documented here must not be accessed, neither in reading nor in writing.

The retention column indicates if the register contents are preserved in power-down mode.

**Table 28. CONTROL REGISTER MAP**

| Add                                     | Name             | Dir | Ret | Reset    | Bit                   |                |                    |               |                  |           |             |                     | Description                           |
|---|------------------|-----|-----|----------|-----------------------|----------------|--------------------|---------------|------------------|-----------|-------------|---------------------|---------------------------------------|
|   |                  |     |     |          | 7                     | 6              | 5                  | 4             | 3                | 2         | 1           | 0                   |                                       |
| <b>Revision &amp; Interface Probing</b> |                  |     |     |          |                       |                |                    |               |                  |           |             |                     |                                       |
| 000                                     | REVISION         | R   | R   | 01010001 | SILICONREV(7:0)       |                |                    |               |                  |           |             |                     | Silicon Revision                      |
| 001                                     | SCRATCH          | RW  | R   | 11000101 | SCRATCH(7:0)          |                |                    |               |                  |           |             |                     | Scratch Register                      |
| <b>Operating Mode</b>                   |                  |     |     |          |                       |                |                    |               |                  |           |             |                     |                                       |
| 002                                     | PWRMODE          | RW  | R   | 011-0000 | RST                   | XOEN           | REFEN              | WDS           | PWRMODE(3:0)     |           |             |                     | Power Mode                            |
| <b>Voltage Regulator</b>                |                  |     |     |          |                       |                |                    |               |                  |           |             |                     |                                       |
| 003                                     | POWSTAT          | R   | R   | -----    | SSUM                  | SREF           | SVREF              | SVANA         | SVMODEM          | SBEVANA   | SBEVMO-DEM  | SVIO                | Power Management Status               |
| 004                                     | POWSTICKYST-AT   | R   | R   | -----    | SSSUM                 | SREF           | SSVREF             | SSVANA        | SSVMODEM         | SSBEVANA  | SSBEVMO-DEM | SSVIO               | Power Management Sticky Status        |
| 005                                     | POWIRQMASK       | RW  | R   | 00000000 | MPWR GOOD             | MSREF          | MSVREF             | MS VANA       | MS VMO-DEM       | MSBE VANA | MSBE VMODEM | MSVIO               | Power Management Interrupt Mask       |
| <b>Interrupt Control</b>                |                  |     |     |          |                       |                |                    |               |                  |           |             |                     |                                       |
| 006                                     | IRQMASK1         | RW  | R   | -000000  | -                     | -              | IRQMASK(13:8)      |               |                  |           |             | IRQ Mask            |                                       |
| 007                                     | IRQMASK0         | RW  | R   | 00000000 | IRQMASK(7:0)          |                |                    |               |                  |           |             |                     | IRQ Mask                              |
| 008                                     | RADIOEVENTM-ASK1 | RW  | R   | -----0   | -                     | -              | -                  | -             | -                | -         | -           | RADIO EVENT MASK(8) | Radio Event Mask                      |
| 009                                     | RADIOEVENTM-ASK0 | RW  | R   | 00000000 | RADIO EVENT MASK(7:0) |                |                    |               |                  |           |             |                     | Radio Event Mask                      |
| 00A                                     | IRQINVERSION1    | RW  | R   | -000000  | -                     | -              | IRQINVERSION(13:8) |               |                  |           |             | IRQ Inversion       |                                       |
| 00B                                     | IRQINVERSION0    | RW  | R   | 00000000 | IRQINVERSION(7:0)     |                |                    |               |                  |           |             |                     | IRQ Inversion                         |
| 00C                                     | IRQREQUEST1      | R   | R   | -----    | -                     | -              | IRQREQUEST(13:8)   |               |                  |           |             | IRQ Request         |                                       |
| 00D                                     | IRQREQUEST0      | R   | R   | -----    | IRQREQUEST(7:0)       |                |                    |               |                  |           |             |                     | IRQ Request                           |
| 00E                                     | RADIOEVENTR-EQ1  | R   |     | -----    | -                     | -              | -                  | -             | -                | -         | -           | RADIO EVENT REQ(8)  | Radio Event Request                   |
| 00F                                     | RADIOEVENTR-EQ0  | R   |     | -----    | RADIO EVENT REQ(7:0)  |                |                    |               |                  |           |             |                     | Radio Event Request                   |
| <b>Modulation &amp; Framing</b>         |                  |     |     |          |                       |                |                    |               |                  |           |             |                     |                                       |
| 010                                     | MODULATION       | RW  | R   | -01000   | -                     | -              | -                  | RX HALF SPEED | MODULATION(3:0)  |           |             |                     | Modulation                            |
| 011                                     | ENCODING         | RW  | R   | -00010   | -                     | -              | -                  | ENC NOSYNC    | ENC MANCH        | ENC SCRAM | ENC DIFF    | ENC INV             | Encoder/Decoder Settings              |
| 012                                     | FRAMING          | RW  | R   | -0000000 | FRMRX                 | CRCMODE(2:0)   |                    |               | FRMMODE(2:0)     |           |             | FABORT              | Framing settings                      |
| 014                                     | CRCINIT3         | RW  | R   | 11111111 | CRCINIT(31:24)        |                |                    |               |                  |           |             |                     | CRC Initialisation Data               |
| 015                                     | CRCINIT2         | RW  | R   | 11111111 | CRCINIT(23:16)        |                |                    |               |                  |           |             |                     | CRC Initialisation Data               |
| 016                                     | CRCINIT1         | RW  | R   | 11111111 | CRCINIT(15:8)         |                |                    |               |                  |           |             |                     | CRC Initialisation Data               |
| 017                                     | CRCINIT0         | RW  | R   | 11111111 | CRCINIT(7:0)          |                |                    |               |                  |           |             |                     | CRC Initialisation Data               |
| <b>Forward Error Correction</b>         |                  |     |     |          |                       |                |                    |               |                  |           |             |                     |                                       |
| 018                                     | FEC              | RW  | R   | 00000000 | SHORT MEM             | RSTVI TER-BI   | FEC NEG            | FEC POS       | FECINPSHIFT(2:0) |           |             | FEC ENA             | FEC (Viterbi) Configuration           |
| 019                                     | FECSYNC          | RW  | R   | 01100010 | FECSYNC(7:0)          |                |                    |               |                  |           |             |                     | Interleaver Synchronisation Threshold |
| 01A                                     | FECSTATUS        | R   | R   | -----    | FEC INV               | MAXMETRIC(6:0) |                    |               |                  |           |             | FEC Status          |                                       |

Table 28. CONTROL REGISTER MAP

| Add                      | Name           | Dir | Ret | Reset    | Bit              |           |               |               |               |                 |             |                | Description                                 |
|--------------------------|----------------|-----|-----|----------|------------------|-----------|---------------|---------------|---------------|-----------------|-------------|----------------|---|
|                          |                |     |     |          | 7                | 6         | 5             | 4             | 3             | 2               | 1           | 0              |   |
| <b>Status</b>            |                |     |     |          |                  |           |               |               |               |                 |             |                |   |
| 01C                      | RADIOSTATE     | R   | –   | 0000     | –                | –         | –             | –             | –             | RADIOSTATE(3:0) |             |                | Radio Controller State                      |
| 01D                      | XTALSTATUS     | R   | R   | –        | –                | –         | –             | –             | –             | –               | –           | XTAL RUN       | Crystal Oscillator Status                   |
| <b>Pin Configuration</b> |                |     |     |          |                  |           |               |               |               |                 |             |                |   |
| 020                      | PINSTATE       | R   | R   | –        | –                | –         | PS PWR AMP    | PS ANT SEL    | PS IRQ        | PS DATA         | PS DCLK     | PS SYS CLK     | Pinstate                                    |
| 021                      | PINFUNCSYSC-LK | RW  | R   | 0—01000  | PU SYSCLK        | –         | –             | PFSYSCLK(4:0) |               |                 |             | –              | SYSCLK Pin Function                         |
| 022                      | PINFUNCDCLK    | RW  | R   | 00—100   | PU DCLK          | PI DCLK   | –             | –             | –             | PFDCLK(2:0)     |             | –              | DCLK Pin Function                           |
| 023                      | PINFUNCDATA    | RW  | R   | 10—111   | PU DATA          | PI DATA   | –             | –             | –             | PFDATA(2:0)     |             | –              | DATA Pin Function                           |
| 024                      | PINFUNCIRQ     | RW  | R   | 00—011   | PU IRQ           | PI IRQ    | –             | –             | –             | PFIRQ(2:0)      |             | –              | IRQ Pin Function                            |
| 025                      | PINFUNCANTS-EL | RW  | R   | 00—110   | PU ANTSEL        | PI ANTSEL | –             | –             | –             | PFANTSEL(2:0)   |             | –              | ANTSEL Pin Function                         |
| 026                      | PINFUNCPWRAMP  | RW  | R   | 00—0110  | PU PWRAMP        | PI PWRAMP | –             | –             | PFPWRAMP(3:0) |                 |             | –              | PWRAMP Pin Function                         |
| 027                      | PWRAMP         | RW  | R   | –—0      | –                | –         | –             | –             | –             | –               | –           | PWRAMP         | PWRAMP Control                              |
| <b>FIFO</b>              |                |     |     |          |                  |           |               |               |               |                 |             |                |   |
| 028                      | FIFOSTAT       | R   | R   | 0—       | FIFO AUTO COMMIT | –         | FIFO FREE THR | FIFO CNT THR  | FIFO OVER     | FIFO UN-DER     | FIFO FULL   | FIFO EMPTY     | FIFO Control                                |
|                          |                | W   | R   | –        | –                | –         | FIFOCMD(5:0)  |               |               |                 |             | –              |   |
| 029                      | FIFODATA       | RW  |     | –        | FIFODATA(7:0)    |           |               |               |               |                 |             | –              | FIFO Data                                   |
| 02A                      | FIFOCOUNT1     | R   | R   | –—0      | –                | –         | –             | –             | –             | –               | –           | FIFO COUNT(8)  | Number of Words currently in FIFO           |
| 02B                      | FIFOCOUNT0     | R   | R   | 00000000 | FIFOCOUNT(7:0)   |           |               |               |               |                 |             | –              | Number of Words currently in FIFO           |
| 02C                      | FIFOFREE1      | R   | R   | –—1      | –                | –         | –             | –             | –             | –               | –           | FIFO FREE(8)   | Number of Words that can be written to FIFO |
| 02D                      | FIFOFREE0      | R   | R   | 00000000 | FIFOFREE(7:0)    |           |               |               |               |                 |             | –              | Number of Words that can be written to FIFO |
| 02E                      | FIFOTHRESH1    | RW  | R   | –—0      | –                | –         | –             | –             | –             | –               | –           | FIFO THRESH(8) | FIFO Threshold                              |
| 02F                      | FIFOTHRESH0    | RW  | R   | 00000000 | FIFOTHRESH(7:0)  |           |               |               |               |                 |             | –              | FIFO Threshold                              |
| <b>Synthesizer</b>       |                |     |     |          |                  |           |               |               |               |                 |             |                |   |
| 030                      | PLLLOOP        | RW  | R   | 0—1001   | FREQB            | –         | –             | –             | DIRECT        | FILT EN         | FLT(1:0)    |                | PLL Loop Filter Settings                    |
| 031                      | PLLCPI         | RW  | R   | 00001000 | PLLCPI           |           |               |               |               |                 |             | –              | PLL Charge Pump Current (Boosted)           |
| 032                      | PLLVCODIV      | RW  | R   | –00–000  | –                | VCOI MAN  | VCO2INT       | VCOSEL        | –             | RFDIV           | REFDIV(1:0) |                | PLL Divider Settings                        |
| 033                      | PLLRANGINGA    | RW  | R   | 00001000 | STICKY LOCK      | PLL LOCK  | RNGERR        | RNG START     | VCORA(3:0)    |                 |             |                | PLL Autoranging                             |
| 034                      | FREQA3         | RW  | R   | 00111001 | FREQA(31:24)     |           |               |               |               |                 |             | –              | Synthesizer Frequency                       |
| 035                      | FREQA2         | RW  | R   | 00110100 | FREQA(23:16)     |           |               |               |               |                 |             | –              | Synthesizer Frequency                       |
| 036                      | FREQA1         | RW  | R   | 11001100 | FREQA(15:8)      |           |               |               |               |                 |             | –              | Synthesizer Frequency                       |
| 037                      | FREQA0         | RW  | R   | 11001101 | FREQA(7:0)       |           |               |               |               |                 |             | –              | Synthesizer Frequency                       |
| 038                      | PLLLOOPBOOS-T  | RW  | R   | 0—1011   | FREQB            | –         | –             | –             | DIRECT        | FILT EN         | FLT(1:0)    |                | PLL Loop Filter Settings (Boosted)          |
| 039                      | PLLCPIBOOST    | RW  | R   | 11001000 | PLLCPI           |           |               |               |               |                 |             | –              | PLL Charge Pump Current                     |
| 03B                      | PLLRANGINGB    | RW  | R   | 00001000 | STICKY LOCK      | PLL LOCK  | RNGERR        | RNG START     | VCORB(3:0)    |                 |             |                | PLL Autoranging                             |
| 03C                      | FREQB3         | RW  | R   | 00111001 | FREQB(31:24)     |           |               |               |               |                 |             | –              | Synthesizer Frequency                       |
| 03D                      | FREQB2         | RW  | R   | 00110100 | FREQB(23:16)     |           |               |               |               |                 |             | –              | Synthesizer Frequency                       |
| 03E                      | FREQB1         | RW  | R   | 11001100 | FREQB(15:8)      |           |               |               |               |                 |             | –              | Synthesizer Frequency                       |
| 03F                      | FREQB0         | RW  | R   | 11001101 | FREQB(7:0)       |           |               |               |               |                 |             | –              | Synthesizer Frequency                       |
| <b>Signal Strength</b>   |                |     |     |          |                  |           |               |               |               |                 |             |                |   |
| 040                      | RSSI           | R   | R   | –        | RSSI(7:0)        |           |               |               |               |                 |             | –              | Received Signal Strength Indicator          |
| 041                      | BGNDRSSI       | RW  | R   | 00000000 | BGNDRSSI(7:0)    |           |               |               |               |                 |             | –              | Background RSSI                             |
| 042                      | DIVERSITY      | RW  | R   | –—00     | –                | –         | –             | –             | –             | –               | ANT SEL     | DIV ENA        | Antenna Diversity Configuration             |

Table 28. CONTROL REGISTER MAP

| Add                              | Name          | Dir | Ret | Reset    | Bit                |                 |                   |   |                    |   |   |                          | Description                      |
|----------------------------------|---------------|-----|-----|----------|--------------------|-----------------|-------------------|---|--------------------|---|---|--------------------------|----------------------------------|
|                                  |               |     |     |          | 7                  | 6               | 5                 | 4 | 3                  | 2 | 1 | 0                        |                                  |
| 043                              | AGCCOUNTER    | RW  | R   | ————     | AGCCOUNTER(7:0)    |                 |                   |   |                    |   |   |                          | AGC Current Value                |
| <b>Receiver Tracking</b>         |               |     |     |          |                    |                 |                   |   |                    |   |   |                          |                                  |
| 045                              | TRKDATARATE2  | R   | R   | ————     | TRKDATARATE(23:16) |                 |                   |   |                    |   |   |                          | Datarate Tracking                |
| 046                              | TRKDATARATE1  | R   | R   | ————     | TRKDATARATE(15:8)  |                 |                   |   |                    |   |   |                          | Datarate Tracking                |
| 047                              | TRKDATARATE0  | R   | R   | ————     | TRKDATARATE(7:0)   |                 |                   |   |                    |   |   |                          | Datarate Tracking                |
| 048                              | TRKAMPL1      | R   | R   | ————     | TRKAMPL(15:8)      |                 |                   |   |                    |   |   |                          | Amplitude Tracking               |
| 049                              | TRKAMPL0      | R   | R   | ————     | TRKAMPL(7:0)       |                 |                   |   |                    |   |   |                          | Amplitude Tracking               |
| 04A                              | TRKPHASE1     | R   | R   | ————     | —                  | —               | —                 | — | TRKPHASE(11:8)     |   |   |                          | Phase Tracking                   |
| 04B                              | TRKPHASE0     | R   | R   | ————     | TRKPHASE(7:0)      |                 |                   |   |                    |   |   |                          | Phase Tracking                   |
| 04D                              | TRKRFFREQ2    | RW  | R   | ————     | —                  | —               | —                 | — | TRRKFREQ(19:16)    |   |   |                          | RF Frequency Tracking            |
| 04E                              | TRKRFFREQ1    | RW  | R   | ————     | TRRKFREQ(15:8)     |                 |                   |   |                    |   |   |                          | RF Frequency Tracking            |
| 04F                              | TRKRFFREQ0    | RW  | R   | ————     | TRRKFREQ(7:0)      |                 |                   |   |                    |   |   |                          | RF Frequency Tracking            |
| 050                              | TRKFREQ1      | RW  | R   | ————     | TRKFREQ(15:8)      |                 |                   |   |                    |   |   |                          | Frequency Tracking               |
| 051                              | TRKFREQ0      | RW  | R   | ————     | TRKFREQ(7:0)       |                 |                   |   |                    |   |   |                          | Frequency Tracking               |
| 052                              | TRKFSKDEMOD1  | R   | R   | ————     | —                  | —               | TRKFSKDEMOD(13:8) |   |                    |   |   | FSK Demodulator Tracking |                                  |
| 053                              | TRKFSKDEMOD0  | R   | R   | ————     | TRKFSKDEMOD(7:0)   |                 |                   |   |                    |   |   |                          | FSK Demodulator Tracking         |
| 054                              | TRKAFSKDEMOD1 | R   | R   | ————     | TRKAFSKDEMOD(15:8) |                 |                   |   |                    |   |   |                          | AFSK Demodulator Tracking        |
| 055                              | TRKAFSKDEMOD0 | R   | R   | ————     | TRKAFSKDEMOD(7:0)  |                 |                   |   |                    |   |   |                          | AFSK Demodulator Tracking        |
| <b>Timer</b>                     |               |     |     |          |                    |                 |                   |   |                    |   |   |                          |                                  |
| 059                              | TIMER2        | R   | —   | ————     | TIMER(23:16)       |                 |                   |   |                    |   |   |                          | 1MHz Timer                       |
| 05A                              | TIMER1        | R   | —   | ————     | TIMER(15:8)        |                 |                   |   |                    |   |   |                          | 1MHz Timer                       |
| 05B                              | TIMER0        | R   | —   | ————     | TIMER(7:0)         |                 |                   |   |                    |   |   |                          | 1MHz Timer                       |
| <b>Wakeup Timer</b>              |               |     |     |          |                    |                 |                   |   |                    |   |   |                          |                                  |
| 068                              | WAKEUPTIMER1  | R   | R   | ————     | WAKEUPTIMER(15:8)  |                 |                   |   |                    |   |   |                          | Wakeup Timer                     |
| 069                              | WAKEUPTIMER0  | R   | R   | ————     | WAKEUPTIMER(7:0)   |                 |                   |   |                    |   |   |                          | Wakeup Timer                     |
| 06A                              | WAKEUP1       | RW  | R   | 00000000 | WAKEUP(15:8)       |                 |                   |   |                    |   |   |                          | Wakeup Time                      |
| 06B                              | WAKEUP0       | RW  | R   | 00000000 | WAKEUP(7:0)        |                 |                   |   |                    |   |   |                          | Wakeup Time                      |
| 06C                              | WAKEUPFREQ1   | RW  | R   | 00000000 | WAKEUPFREQ(15:8)   |                 |                   |   |                    |   |   |                          | Wakeup Frequency                 |
| 06D                              | WAKEUPFREQ0   | RW  | R   | 00000000 | WAKEUPFREQ(7:0)    |                 |                   |   |                    |   |   |                          | Wakeup Frequency                 |
| 06E                              | WAKEUPXOEARLY | RW  | R   | 00000000 | WAKEUPXOEARLY      |                 |                   |   |                    |   |   |                          | Wakeup Crystal Oscillator Early  |
| <b>Physical Layer Parameters</b> |               |     |     |          |                    |                 |                   |   |                    |   |   |                          |                                  |
| <b>Receiver Parameters</b>       |               |     |     |          |                    |                 |                   |   |                    |   |   |                          |                                  |
| 100                              | IFFREQ1       | RW  | R   | 00010001 | IFFREQ(15:8)       |                 |                   |   |                    |   |   |                          | 2nd LO / IF Frequency            |
| 101                              | IFFREQ0       | RW  | R   | 00100111 | IFFREQ(7:0)        |                 |                   |   |                    |   |   |                          | 2nd LO / IF Frequency            |
| 102                              | DECIMATION    | RW  | R   | —0001101 | —                  | DECIMATION(6:0) |                   |   |                    |   |   | Decimation Factor        |                                  |
| 103                              | RXDATARATE2   | RW  | R   | 00000000 | RXDATARATE(23:16)  |                 |                   |   |                    |   |   |                          | Receiver Datarate                |
| 104                              | RXDATARATE1   | RW  | R   | 00111101 | RXDATARATE(15:8)   |                 |                   |   |                    |   |   |                          | Receiver Datarate                |
| 105                              | RXDATARATE0   | RW  | R   | 10001010 | RXDATARATE(7:0)    |                 |                   |   |                    |   |   |                          | Receiver Datarate                |
| 106                              | MAXDROFFSET2  | RW  | R   | 00000000 | MAXDROFFSET(23:16) |                 |                   |   |                    |   |   |                          | Maximum Receiver Datarate Offset |
| 107                              | MAXDROFFSET1  | RW  | R   | 00000000 | MAXDROFFSET(15:8)  |                 |                   |   |                    |   |   |                          | Maximum Receiver Datarate Offset |
| 108                              | MAXDROFFSET0  | RW  | R   | 10011110 | MAXDROFFSET(7:0)   |                 |                   |   |                    |   |   |                          | Maximum Receiver Datarate Offset |
| 109                              | MAXRFOFFSET2  | RW  | R   | 0—0000   | FREQ OFFS CORR     | —               | —                 | — | MAXRFOFFSET(19:16) |   |   |                          | Maximum Receiver RF Offset       |

Table 28. CONTROL REGISTER MAP

| Add | Name           | Dir | Ret | Reset    | Bit               |   |            |                    |                 |           |            |  | Description                        |                                |
|-----|----------------|-----|-----|----------|-------------------|---|------------|--------------------|-----------------|-----------|------------|--|------------------------------------|--------------------------------|
|     |                |     |     |          | 7                 | 6 | 5          | 4                  | 3               | 2         | 1          | 0  |                                    |                                |
| 10A | MAXRFOFFSET1   | RW  | R   | 00010110 | MAXRFOFFSET(15:8) |   |            |                    |                 |           |            |  | Maximum Receiver RF Offset         |                                |
| 10B | MAXRFOFFSET0   | RW  | R   | 10000111 | MAXRFOFFSET(7:0)  |   |            |                    |                 |           |            |  | Maximum Receiver RF Offset         |                                |
| 10C | FSKDMAX1       | RW  | R   | 00000000 | FSKDEVMAX(15:8)   |   |            |                    |                 |           |            |  | Four FSK Rx Deviation              |                                |
| 10D | FSKDMAX0       | RW  | R   | 10000000 | FSKDEVMAX(7:0)    |   |            |                    |                 |           |            |  | Four FSK Rx Deviation              |                                |
| 10E | FSKDMIN1       | RW  | R   | 11111111 | FSKDEVMIN(15:8)   |   |            |                    |                 |           |            |  | Four FSK Rx Deviation              |                                |
| 10F | FSKDMIN0       | RW  | R   | 10000000 | FSKDEVMIN(7:0)    |   |            |                    |                 |           |            |  | Four FSK Rx Deviation              |                                |
| 110 | AFSKSPACE1     | RW  | R   | 0000     | -                 | - | -          | -                  | AFSKSPACE(11:8) |           |            |  | AFSK Space (0) Frequency           |                                |
| 111 | AFSKSPACE0     | RW  | R   | 01000000 | AFSKSPACE(7:0)    |   |            |                    |                 |           |            |  | AFSK Space (0) Frequency           |                                |
| 112 | AFSKMARK1      | RW  | R   | 0000     | -                 | - | -          | -                  | AFSKMARK(11:8)  |           |            |  | AFSK Mark (1) Frequency            |                                |
| 113 | AFSKMARK0      | RW  | R   | 01110101 | AFSKMARK(7:0)     |   |            |                    |                 |           |            |  | AFSK Mark (1) Frequency            |                                |
| 114 | AFSKCTRL       | RW  | R   | 00100    | -                 | - | -          | AFSKSHIFT0(4:0)    |                 |           |            | AFSK Control                               |                                    |                                |
| 115 | AMPLFILTER     | RW  | R   | 0000     | -                 | - | -          | AMPLFILTER(3:0)    |                 |           |            | Amplitude Filter                           |                                    |                                |
| 116 | FREQUENCYLEAK  | RW  | R   | 0000     | -                 | - | -          | FREQUENCYLEAK(3:0) |                 |           |            | Baseband Frequency Recovery Loop Leakiness |                                    |                                |
| 117 | RXPARAMSETS    | RW  | R   | 00000000 | RXPS3(1:0)        |   | RXPS2(1:0) |                    | RXPS1(1:0)      |           | RXPS0(1:0) |  | Receiver Parameter Set Indirection |                                |
| 118 | RXPARAMCURRENT | R   | R   |          | -                 | - | -          | RXSN(2)            |                 | RXSN(1:0) |            | RXSI(1:0)                                  |                                    | Receiver Parameter Current Set |

Receiver Parameter Set 0

|     |            |    |   |          |                 |                |               |                 |                 |                |                |                  |  |
|-----|------------|----|---|----------|-----------------|----------------|---------------|-----------------|-----------------|----------------|----------------|------------------|--|
| 120 | AGCGAIN0   | RW | R | 10110100 | AGCDECAY0(3:0)  |                |               |                 | AGCATTACK0(3:0) |                |                |                  | AGC Speed                              |
| 121 | AGCTARGET0 | RW | R | 01110110 | AGCTARGET0(7:0) |                |               |                 |                 |                |                |                  | AGC Target                             |
| 122 | AGCAHYST0  | RW | R | 000      | -               |                |               |                 |                 |                | AGCAHYST0(2:0) |                  | AGC Digital Threshold Range            |
| 123 | AGCMINMAX0 | RW | R | 000000   | -               | AGCMAXDA0(2:0) |               |                 | -               | AGCMINDA0(2:0) |                |                  | AGC Digital Min/Max Set Points         |
| 124 | TIMEGAIN0  | RW | R | 11111000 | TIMEGAIN0M      |                |               |                 | TIMEGAIN0E      |                |                |                  | Timing Gain                            |
| 125 | DRGAIN0    | RW | R | 11110010 | DRGAIN0M        |                |               |                 | DRGAIN0E        |                |                |                  | Data Rate Gain                         |
| 126 | PHASEGAIN0 | RW | R | 110011   | FILTERIDX0(1:0) |                | -             | -               | PHASEGAIN0(3:0) |                |                |                  | Filter Index, Phase Gain               |
| 127 | FREQGAINA0 | RW | R | 00001111 | FREQ LIM0       | FREQ MODULE0   | FREQ HALFMOD0 | FREQ AMPL GATE0 | FREQGAINA0(3:0) |                |                |                  | Frequency Gain A                       |
| 128 | FREQGAINB0 | RW | R | 00111111 | FREQ FREEZE0    | FREQ AVG0      | -             | FREQGAINB0(4:0) |                 |                |                | Frequency Gain B |  |
| 129 | FREQGAINC0 | RW | R | 001010   | -               | -              | -             | FREQGAINC0(4:0) |                 |                |                | Frequency Gain C |  |
| 12A | FREQGAIND0 | RW | R | 001010   | RFFREQ FREEZE0  | -              | -             | FREQGAIND0(4:0) |                 |                |                | Frequency Gain D |  |
| 12B | AMPLGAIN0  | RW | R | 010110   | AMPL AVG        | AMPL AGC       | -             | -               | AMPLGAIN0(3:0)  |                |                |                  | Amplitude Gain                         |
| 12C | FREQDEV10  | RW | R | 0000     | -               | -              | -             | -               | FREQDEV0(11:8)  |                |                |                  | Receiver Frequency Deviation           |
| 12D | FREQDEV00  | RW | R | 00100000 | FREQDEV0(7:0)   |                |               |                 |                 |                |                |                  | Receiver Frequency Deviation           |
| 12E | FOURFSK0   | RW | R | 010110   | -               | -              | -             | DEV UP-DATE0    | DEVDECAY0(3:0)  |                |                |                  | Four FSK Control                       |
| 12F | BBOFFSRES0 | RW | R | 10001000 | RESINTB0(3:0)   |                |               |                 | RESINTA0(3:0)   |                |                |                  | Baseband Offset Compensation Resistors |

Receiver Parameter Set 1

|     |            |    |   |          |                 |                |   |   |                 |                |                |  |                                |
|-----|------------|----|---|----------|-----------------|----------------|---|---|-----------------|----------------|----------------|--|--------------------------------|
| 130 | AGCGAIN1   | RW | R | 10110100 | AGCDECAY1(3:0)  |                |   |   | AGCATTACK1(3:0) |                |                |  | AGC Speed                      |
| 131 | AGCTARGET1 | RW | R | 01110110 | AGCTARGET1(7:0) |                |   |   |                 |                |                |  | AGC Target                     |
| 132 | AGCAHYST1  | RW | R | 000      | -               |                |   |   |                 |                | AGCAHYST1(2:0) |  | AGC Digital Threshold Range    |
| 133 | AGCMINMAX1 | RW | R | 000000   | -               | AGCMAXDA1(2:0) |   |   | -               | AGCMINDA1(2:0) |                |  | AGC Digital Min/Max Set Points |
| 134 | TIMEGAIN1  | RW | R | 11110110 | TIMEGAIN1M      |                |   |   | TIMEGAIN1E      |                |                |  | Timing Gain                    |
| 135 | DRGAIN1    | RW | R | 11110001 | DRGAIN1M        |                |   |   | DRGAIN1E        |                |                |  | Data Rate Gain                 |
| 136 | PHASEGAIN1 | RW | R | 110011   | FILTERIDX1(1:0) |                | - | - | PHASEGAIN1(3:0) |                |                |  | Filter Index, Phase Gain       |

Table 28. CONTROL REGISTER MAP

| Add | Name       | Dir | Ret | Reset    | Bit            |              |               |                  |                 |   |  |                  | Description |
|-----|------------|-----|-----|----------|----------------|--------------|---------------|------------------|-----------------|---|--|------------------|-------------|
|     |            |     |     |          | 7              | 6            | 5             | 4                | 3               | 2 | 1                                      | 0                |             |
| 137 | FREQGAINA1 | RW  | R   | 00001111 | FREQ LIM1      | FREQ MODULO1 | FREQ HALFMOD1 | FREQ AM-PL GATE1 | FREQGAINA1(3:0) |   |  | Frequency Gain A |             |
| 138 | FREQGAINB1 | RW  | R   | 00—1111  | FREQ FREEZE1   | FREQ AVG1    | —             | FREQGAINB1(4:0)  |                 |   | Frequency Gain B                       |                  |             |
| 139 | FREQGAINC1 | RW  | R   | —01011   | —              | —            | —             | FREQGAINC1(4:0)  |                 |   | Frequency Gain C                       |                  |             |
| 13A | FREQGAIND1 | RW  | R   | 0—01011  | RFFREQ FREEZE1 | —            | —             | FREQGAIND1(4:0)  |                 |   | Frequency Gain D                       |                  |             |
| 13B | AMPLGAIN1  | RW  | R   | 01—0110  | AMPL AVG1      | AMPL1 AGC1   | —             | —                | AMPLGAIN1(3:0)  |   | Amplitude Gain                         |                  |             |
| 13C | FREQDEV11  | RW  | R   | —0000    | —              | —            | —             | FREQDEV1(11:8)   |                 |   | Receiver Frequency Deviation           |                  |             |
| 13D | FREQDEV01  | RW  | R   | 00100000 | FREQDEV1(7:0)  |              |               |                  |                 |   | Receiver Frequency Deviation           |                  |             |
| 13E | FOURFSK1   | RW  | R   | —11000   | —              | —            | —             | DEV UP-DATE1     | DEVDECAY1(3:0)  |   | Four FSK Control                       |                  |             |
| 13F | BBOFFSRES1 | RW  | R   | 10001000 | RESINTB1(3:0)  |              |               | RESINTA1(3:0)    |                 |   | Baseband Offset Compensation Resistors |                  |             |

Receiver Parameter Set 2

|     |            |    |   |          |                 |                |               |                  |                 |  |  |                  |
|-----|------------|----|---|----------|-----------------|----------------|---------------|------------------|-----------------|--|--|------------------|
| 140 | AGCGAIN2   | RW | R | 11111111 | AGCDECAY2(3:0)  |                |               | AGCATTACK2(3:0)  |                 |  | AGC Speed                              |                  |
| 141 | AGCTARGET2 | RW | R | 01110110 | AGCTARGET2(7:0) |                |               |                  |                 |  | AGC Target                             |                  |
| 142 | AGCAHYST2  | RW | R | —000     | —               |                |               | AGCAHYST2(2:0)   |                 |  | AGC Digital Threshold Range            |                  |
| 143 | AGCMINMAX2 | RW | R | —000—000 | —               | AGCMAXDA2(2:0) |               | —                | AGCMINDA2(2:0)  |  | AGC Digital Min/Max Set Points         |                  |
| 144 | TIMEGAIN2  | RW | R | 11110101 | TIMEGAIN2M      |                |               | TIMEGAIN2E       |                 |  | Timing Gain                            |                  |
| 145 | DRGAIN2    | RW | R | 11110000 | DRGAIN2M        |                |               | DRGAIN2E         |                 |  | Data Rate Gain                         |                  |
| 146 | PHASEGAIN2 | RW | R | 11—0011  | FILTERIDX2(1:0) |                | —             | —                | PHASEGAIN2(3:0) |  | Filter Index, Phase Gain               |                  |
| 147 | FREQGAINA2 | RW | R | 00001111 | FREQ LIM2       | FREQ MODULO2   | FREQ HALFMOD2 | FREQ AM-PL GATE2 | FREQGAINA2(3:0) |  |  | Frequency Gain A |
| 148 | FREQGAINB2 | RW | R | 00—1111  | FREQ FREEZE2    | FREQ AVG2      | —             | FREQGAINB2(4:0)  |                 |  | Frequency Gain B                       |                  |
| 149 | FREQGAINC2 | RW | R | —01101   | —               | —              | —             | FREQGAINC2(4:0)  |                 |  | Frequency Gain C                       |                  |
| 14A | FREQGAIND2 | RW | R | 0—01101  | RFFREQ FREEZE2  | —              | —             | FREQGAIND2(4:0)  |                 |  | Frequency Gain D                       |                  |
| 14B | AMPLGAIN2  | RW | R | 01—0110  | AMPL AVG2       | AMPL AGC2      | —             | —                | AMPLGAIN2(3:0)  |  | Amplitude Gain                         |                  |
| 14C | FREQDEV12  | RW | R | —0000    | —               | —              | —             | FREQDEV2(11:8)   |                 |  | Receiver Frequency Deviation           |                  |
| 14D | FREQDEV02  | RW | R | 00100000 | FREQDEV2(7:0)   |                |               |                  |                 |  | Receiver Frequency Deviation           |                  |
| 14E | FOURFSK2   | RW | R | —11010   | —               | —              | —             | DEV UP-DATE2     | DEVDECAY2(3:0)  |  | Four FSK Control                       |                  |
| 14F | BBOFFSRES2 | RW | R | 10001000 | RESINTB2(3:0)   |                |               | RESINTA2(3:0)    |                 |  | Baseband Offset Compensation Resistors |                  |

Receiver Parameter Set 3

|     |            |    |   |          |                 |                |               |                  |                 |  |                                |                  |
|-----|------------|----|---|----------|-----------------|----------------|---------------|------------------|-----------------|--|--------------------------------|------------------|
| 150 | AGCGAIN3   | RW | R | 11111111 | AGCDECAY3(3:0)  |                |               | AGCATTACK3(3:0)  |                 |  | AGC Speed                      |                  |
| 151 | AGCTARGET3 | RW | R | 01110110 | AGCTARGET3(7:0) |                |               |                  |                 |  | AGC Target                     |                  |
| 152 | AGCAHYST3  | RW | R | —000     | —               |                |               | AGCAHYST3(2:0)   |                 |  | AGC Digital Threshold Range    |                  |
| 153 | AGCMINMAX3 | RW | R | —000—000 | —               | AGCMAXDA3(2:0) |               | —                | AGCMINDA3(2:0)  |  | AGC Digital Min/Max Set Points |                  |
| 154 | TIMEGAIN3  | RW | R | 11110101 | TIMEGAIN3M      |                |               | TIMEGAIN3E       |                 |  | Timing Gain                    |                  |
| 155 | DRGAIN3    | RW | R | 11110000 | DRGAIN3M        |                |               | DRGAIN3E         |                 |  | Data Rate Gain                 |                  |
| 156 | PHASEGAIN3 | RW | R | 11—0011  | FILTERIDX3(1:0) |                | —             | —                | PHASEGAIN3(3:0) |  | Filter Index, Phase Gain       |                  |
| 157 | FREQGAINA3 | RW | R | 00001111 | FREQ LIM3       | FREQ MODULO3   | FREQ HALFMOD3 | FREQ AM-PL GATE3 | FREQGAINA3(3:0) |  |                                | Frequency Gain A |
| 158 | FREQGAINB3 | RW | R | 00—1111  | FREQ FREEZE3    | FREQ AVG3      | —             | FREQGAINB3(4:0)  |                 |  | Frequency Gain B               |                  |
| 159 | FREQGAINC3 | RW | R | —01101   | —               | —              | —             | FREQGAINC3(4:0)  |                 |  | Frequency Gain C               |                  |
| 15A | FREQGAIND3 | RW | R | 0—01101  | RFFREQ FREEZE3  | —              | —             | FREQGAIND3(4:0)  |                 |  | Frequency Gain D               |                  |
| 15B | AMPLGAIN3  | RW | R | 01—0110  | AMPL AVG3       | AMPL AGC3      | —             | —                | AMPLGAIN3(3:0)  |  | Amplitude Gain                 |                  |

Table 28. CONTROL REGISTER MAP

| Add | Name       | Dir | Ret | Reset    | Bit           |   |   |              |                |   |   |   | Description                            |
|-----|------------|-----|-----|----------|---------------|---|---|--------------|----------------|---|---|---|--|
|     |            |     |     |          | 7             | 6 | 5 | 4            | 3              | 2 | 1 | 0 |  |
| 15C | FREQDEV13  | RW  | R   | 0000     | –             | – | – | –            | FREQDEV3(11:8) |   |   |   | Receiver Frequency Deviation           |
| 15D | FREQDEV03  | RW  | R   | 00100000 | FREQDEV3(7:0) |   |   |              |                |   |   |   | Receiver Frequency Deviation           |
| 15E | FOURFSK3   | RW  | R   | 11010    | –             | – | – | DEV UP-DATE3 | DEVDECAY3(3:0) |   |   |   | Four FSK Control                       |
| 15F | BBOFFSRES3 | RW  | R   | 10001000 | RESINTB3(3:0) |   |   |              | RESINTA3(3:0)  |   |   |   | Baseband Offset Compensation Resistors |

**Transmitter Parameters**

|     |               |    |   |          |                   |             |           |   |   |            |            |                           |   |
|-----|---------------|----|---|----------|-------------------|-------------|-----------|---|---|------------|------------|---------------------------|---|
| 160 | MODCFGF       | RW | R | 00       | –                 | –           | –         | – | – | –          | FREQ SHAPE | Modulator Configuration F |   |
| 161 | FSKDEV2       | RW | R | 00000000 | FSKDEV(23:16)     |             |           |   |   |            |            |                           | FSK Frequency Deviation                 |
| 162 | FSKDEV1       | RW | R | 00001010 | FSKDEV(15:8)      |             |           |   |   |            |            |                           | FSK Frequency Deviation                 |
| 163 | FSKDEV0       | RW | R | 00111101 | FSKDEV(7:0)       |             |           |   |   |            |            |                           | FSK Frequency Deviation                 |
| 164 | MODCFGGA      | RW | R | 0000–101 | BROWN GATE        | PTTLCK GATE | SLOW RAMP |   | – | AMPL SHAPE | TX SE      | TX DIFF                   | Modulator Configuration A               |
| 165 | TXRATE2       | RW | R | 00000000 | TXRATE(23:16)     |             |           |   |   |            |            |                           | Transmitter Bitrate                     |
| 166 | TXRATE1       | RW | R | 00101000 | TXRATE(15:8)      |             |           |   |   |            |            |                           | Transmitter Bitrate                     |
| 167 | TXRATE0       | RW | R | 11110110 | TXRATE(7:0)       |             |           |   |   |            |            |                           | Transmitter Bitrate                     |
| 168 | TXPWRCOEFF-A1 | RW | R | 00000000 | TXPWRCOEFFA(15:8) |             |           |   |   |            |            |                           | Transmitter Predistortion Coefficient A |
| 169 | TXPWRCOEFF-A0 | RW | R | 00000000 | TXPWRCOEFFA(7:0)  |             |           |   |   |            |            |                           | Transmitter Predistortion Coefficient A |
| 16A | TXPWRCOEFF-B1 | RW | R | 00001111 | TXPWRCOEFFB(15:8) |             |           |   |   |            |            |                           | Transmitter Predistortion Coefficient B |
| 16B | TXPWRCOEFF-B0 | RW | R | 11111111 | TXPWRCOEFFB(7:0)  |             |           |   |   |            |            |                           | Transmitter Predistortion Coefficient B |
| 16C | TXPWRCOEFF-C1 | RW | R | 00000000 | TXPWRCOEFFC(15:8) |             |           |   |   |            |            |                           | Transmitter Predistortion Coefficient C |
| 16D | TXPWRCOEFF-C0 | RW | R | 00000000 | TXPWRCOEFFC(7:0)  |             |           |   |   |            |            |                           | Transmitter Predistortion Coefficient C |
| 16E | TXPWRCOEFF-D1 | RW | R | 00000000 | TXPWRCOEFFD(15:8) |             |           |   |   |            |            |                           | Transmitter Predistortion Coefficient D |
| 16F | TXPWRCOEFF-D0 | RW | R | 00000000 | TXPWRCOEFFD(7:0)  |             |           |   |   |            |            |                           | Transmitter Predistortion Coefficient D |
| 170 | TXPWRCOEFF-E1 | RW | R | 00000000 | TXPWRCOEFFE(15:8) |             |           |   |   |            |            |                           | Transmitter Predistortion Coefficient E |
| 171 | TXPWRCOEFF-E0 | RW | R | 00000000 | TXPWRCOEFFE(7:0)  |             |           |   |   |            |            |                           | Transmitter Predistortion Coefficient E |

**PLL Parameters**

|     |            |    |   |          |             |            |           |   |                |               |                       |                       |
|-----|------------|----|---|----------|-------------|------------|-----------|---|----------------|---------------|-----------------------|-----------------------|
| 180 | PLLVCOI    | RW | R | 0–010010 | VCOIE       | –          | VCOI(5:0) |   |                |               |                       | VCO Current           |
| 181 | PLLVCOIR   | RW | R | –        | –           | VCOIR(5:0) |           |   |                |               | VCO Current Read-back |                       |
| 182 | PLLLOCKDET | RW | R | –011     | LOCKDETDLYR |            | –         | – | –              | LOCK DET DLYM | LOCKDETDLY            | PLL Lock Detect Delay |
| 183 | PLLRNGCLK  | RW | R | –011     | –           | –          | –         | – | PLLRNGCLK(2:0) |               |                       | PLL Ranging Clock     |

**Crystal Oscillator**

|     |         |    |   |          |              |  |  |  |  |  |  |  |                                     |
|-----|---------|----|---|----------|--------------|--|--|--|--|--|--|--|-------------------------------------|
| 184 | XTALCAP | RW | R | 00000000 | XTALCAP(7:0) |  |  |  |  |  |  |  | Crystal Oscillator Load Capacitance |
|-----|---------|----|---|----------|--------------|--|--|--|--|--|--|--|-------------------------------------|

Table 28. CONTROL REGISTER MAP

| Add                         | Name           | Dir | Ret | Reset    | Bit              |                |              |                 |               |                |   |   | Description |
|-----------------------------|----------------|-----|-----|----------|------------------|----------------|--------------|-----------------|---------------|----------------|---|---|-------------|
|                             |                |     |     |          | 7                | 6              | 5            | 4               | 3             | 2              | 1   | 0                                       |             |
| <b>Baseband</b>             |                |     |     |          |                  |                |              |                 |               |                |   |   |             |
| 188                         | BBTUNE         | RW  | R   | —01001   | —                | —              | —            | BB TUNE RUN     | BBTUNE(3:0)   |                |   | Baseband Tuning                         |             |
| 189                         | BBOFFSCAP      | RW  | R   | —111—111 | —                | CAP INT B(2:0) |              |                 | —             | CAP INT A(2:0) |   | Baseband Offset Compensation Capacitors |             |
| <b>MAC Layer Parameters</b> |                |     |     |          |                  |                |              |                 |               |                |   |   |             |
| <b>Packet Format</b>        |                |     |     |          |                  |                |              |                 |               |                |   |   |             |
| 200                         | PKTADDRCFG     | RW  | R   | 001—0000 | MSB FIRST        | CRC SKIP FIRST | FEC SYNC DIS | —               | ADDR POS(3:0) |                |   | Packet Address Config                   |             |
| 201                         | PKTLENCFG      | RW  | R   | 00000000 | LEN BITS(3:0)    |                |              | LEN POS(3:0)    |               |                | Packet Length Config                        |   |             |
| 202                         | PKTLENOFFSET   | RW  | R   | 00000000 | LEN OFFSET(7:0)  |                |              |                 |               |                | Packet Length Offset                        |   |             |
| 203                         | PKTMAXLEN      | RW  | R   | 00000000 | MAX LEN(7:0)     |                |              |                 |               |                | Packet Maximum Length                       |   |             |
| 204                         | PKTADDR3       | RW  | R   | 00000000 | ADDR(31:24)      |                |              |                 |               |                | Packet Address 3                            |   |             |
| 205                         | PKTADDR2       | RW  | R   | 00000000 | ADDR(23:16)      |                |              |                 |               |                | Packet Address 2                            |   |             |
| 206                         | PKTADDR1       | RW  | R   | 00000000 | ADDR(15:8)       |                |              |                 |               |                | Packet Address 1                            |   |             |
| 207                         | PKTADDR0       | RW  | R   | 00000000 | ADDR(7:0)        |                |              |                 |               |                | Packet Address 0                            |   |             |
| 208                         | PKTADDRMASK3   | RW  | R   | 00000000 | ADDRMASK(31:24)  |                |              |                 |               |                | Packet Address Mask 1                       |   |             |
| 209                         | PKTADDRMASK2   | RW  | R   | 00000000 | ADDRMASK(23:16)  |                |              |                 |               |                | Packet Address Mask 0                       |   |             |
| 20A                         | PKTADDRMASK1   | RW  | R   | 00000000 | ADDRMASK(15:8)   |                |              |                 |               |                | Packet Address Mask 1                       |   |             |
| 20B                         | PKTADDRMASK0   | RW  | R   | 00000000 | ADDRMASK(7:0)    |                |              |                 |               |                | Packet Address Mask 0                       |   |             |
| <b>Pattern Match</b>        |                |     |     |          |                  |                |              |                 |               |                |   |   |             |
| 210                         | MATCHOPAT3     | RW  | R   | 00000000 | MATCHOPAT(31:24) |                |              |                 |               |                | Pattern Match Unit 0, Pattern               |   |             |
| 211                         | MATCHOPAT2     | RW  | R   | 00000000 | MATCHOPAT(23:16) |                |              |                 |               |                | Pattern Match Unit 0, Pattern               |   |             |
| 212                         | MATCHOPAT1     | RW  | R   | 00000000 | MATCHOPAT(15:8)  |                |              |                 |               |                | Pattern Match Unit 0, Pattern               |   |             |
| 213                         | MATCHOPAT0     | RW  | R   | 00000000 | MATCHOPAT(7:0)   |                |              |                 |               |                | Pattern Match Unit 0, Pattern               |   |             |
| 214                         | MATCH0LEN      | RW  | R   | 0—00000  | MATCH0 RAW       | —              | —            | MATCH0LEN       |               |                | Pattern Match Unit 0, Pattern Length        |   |             |
| 215                         | MATCH0MIN      | RW  | R   | —00000   | —                | —              | —            | MATCH0MIN       |               |                | Pattern Match Unit 0, Minimum Match         |   |             |
| 216                         | MATCH0MAX      | RW  | R   | —11111   | —                | —              | —            | MATCH0MAX       |               |                | Pattern Match Unit 0, Maximum Match         |   |             |
| 218                         | MATCH1PAT1     | RW  | R   | 00000000 | MATCH1PAT(15:8)  |                |              |                 |               |                | Pattern Match Unit 1, Pattern               |   |             |
| 219                         | MATCH1PAT0     | RW  | R   | 00000000 | MATCH1PAT(7:0)   |                |              |                 |               |                | Pattern Match Unit 1, Pattern               |   |             |
| 21C                         | MATCH1LEN      | RW  | R   | 0—0000   | MATCH1 RAW       | —              | —            | —               | MATCH1LEN     |                |   | Pattern Match Unit 1, Pattern Length    |             |
| 21D                         | MATCH1MIN      | RW  | R   | —0000    | —                | —              | —            | MATCH1MIN       |               |                | Pattern Match Unit 1, Minimum Match         |   |             |
| 21E                         | MATCH1MAX      | RW  | R   | —1111    | —                | —              | —            | MATCH1MAX       |               |                | Pattern Match Unit 1, Maximum Match         |   |             |
| <b>Packet Controller</b>    |                |     |     |          |                  |                |              |                 |               |                |   |   |             |
| 220                         | TMGTXBBOOST    | RW  | R   | 00110010 | TMGTXBBOOSTE     |                |              | TMGTXBBOOSTM    |               |                | Transmit PLL Boost Time                     |   |             |
| 221                         | TMGTXSETTLE    | RW  | R   | 00001010 | TMGTXSETTLEE     |                |              | TMGTXSETTLEM    |               |                | Transmit PLL (post Boost) Settling Time     |   |             |
| 223                         | TMGRXBBOOST    | RW  | R   | 00110010 | TMGRXBBOOSTE     |                |              | TMGRXBBOOSTM    |               |                | Receive PLL Boost Time                      |   |             |
| 224                         | TMGRXSETTLE    | RW  | R   | 00010100 | TMGRXSETTLEE     |                |              | TMGRXSETTLEM    |               |                | Receive PLL (post Boost) Settling Time      |   |             |
| 225                         | TMGRXOFFSACQ   | RW  | R   | 01110011 | TMGRXOFFSACQE    |                |              | TMGRXOFFSACQM   |               |                | Receive Baseband DC Offset Acquisition Time |   |             |
| 226                         | TMGRXCOARSEAGC | RW  | R   | 00111001 | TMGRXCOARSEAGCE  |                |              | TMGRXCOARSEAGCM |               |                | Receive Coarse AGC Time                     |   |             |
| 227                         | TMGRXAGC       | RW  | R   | 00000000 | TMGRXAGCE        |                |              | TMGRXAGCM       |               |                | Receiver AGC Settling Time                  |   |             |



Table 28. CONTROL REGISTER MAP

| Add | Name           | Dir | Ret | Reset    | Bit             |             |             |                   |                 |           |            |                                    | Description                             |
|-----|----------------|-----|-----|----------|-----------------|-------------|-------------|-------------------|-----------------|-----------|------------|------------------------------------|---|
|     |                |     |     |          | 7               | 6           | 5           | 4                 | 3               | 2         | 1          | 0                                  |   |
| 228 | TMGRXRSSI      | RW  | R   | 00000000 | TMGRXRSSIE      |             |             |                   | TMGRXRSSIM      |           |            |                                    | Receiver RSSI Settling Time             |
| 229 | TMGRXPREAMBLE1 | RW  | R   | 00000000 | TMGRXPREAMBLE1E |             |             |                   | TMGRXPREAMBLE1M |           |            |                                    | Receiver Preamble 1 Timeout             |
| 22A | TMGRXPREAMBLE2 | RW  | R   | 00000000 | TMGRXPREAMBLE2E |             |             |                   | TMGRXPREAMBLE2M |           |            |                                    | Receiver Preamble 2 Timeout             |
| 22B | TMGRXPREAMBLE3 | RW  | R   | 00000000 | TMGRXPREAMBLE3E |             |             |                   | TMGRXPREAMBLE3M |           |            |                                    | Receiver Preamble 3 Timeout             |
| 22C | RSSIREFERENCE  | RW  | R   | 00000000 | RSSIREFERENCE   |             |             |                   |                 |           |            |                                    | RSSI Offset                             |
| 22D | RSSIABSTHR     | RW  | R   | 00000000 | RSSIABSTHR      |             |             |                   |                 |           |            |                                    | RSSI Absolute Threshold                 |
| 22E | BGNDRSSIGAIN   | RW  | R   | —0000    | —               | —           | —           | —                 | BGNDRSSIGAIN    |           |            |                                    | Background RSSI Averaging Time Constant |
| 22F | BGNDRSSITHR    | RW  | R   | —000000  | —               | —           | BGNDRSSITHR |                   |                 |           |            | Background RSSI Relative Threshold |   |
| 230 | PKTCHUNKSIZE   | RW  | R   | —0000    | —               | —           | —           | PKTCHUNKSIZE(3:0) |                 |           |            | Packet Chunk Size                  |   |
| 231 | PKTMISCFLAGS   | RW  | R   | —00000   | —               | —           | —           | WOR MULTI PKT     | AGC SETTLE      | BGND RSSI | RXAGC CLK  | RXRSSI CLK                         | Packet Controller Miscellaneous Flags   |
| 232 | PKTSTOREFLAGS  | RW  | R   | —0000000 | —               | ST ANT RSSI | ST CRCB     | ST RSSI           | ST DR           | ST RFOFFS | ST FOFFS   | ST TIMER                           | Packet Controller Store Flags           |
| 233 | PKTACCEPTFLAGS | RW  | R   | —000000  | —               | —           | ACCPTRGRP   | ACCPTRSZF         | ACCPTRDRF       | ACCPTRCRF | ACCPTRABRT | ACCPTRRESIDUE                      | Packet Controller Accept Flags          |

Special Functions

General Purpose ADC

|     |               |    |   |          |                   |   |   |   |   |                   |      |               |                             |
|-----|---------------|----|---|----------|-------------------|---|---|---|---|-------------------|------|---------------|-----------------------------|
| 300 | GPADCCTRL     | RW | R | —000000  | BUSY              | — | 0 | 0 | 0 | GPADC13           | CONT | CH ISOL       | General Purpose ADC Control |
| 301 | GPADCPERIOD   | RW | R | 00111111 | GPADCPERIOD(7:0)  |   |   |   |   |                   |      |               | GPADC Sampling Period       |
| 308 | GPADC13VALUE1 | R  |   | —        | —                 | — | — | — | — | GPADC13VALUE(9:8) |      | GPADC13 Value |                             |
| 309 | GPADC13VALUE0 | R  |   | —        | GPADC13VALUE(7:0) |   |   |   |   |                   |      |               | GPADC13 Value               |

Low Power Oscillator Calibration

|     |             |    |  |          |                  |                   |              |              |            |            |            |           |  |
|-----|-------------|----|--|----------|------------------|-------------------|--------------|--------------|------------|------------|------------|-----------|--|
| 310 | LPOSCCONFIG | RW |  | 00000000 | LPOSC OSC INVERT | LPOSC OSC DOUBBLE | LPOSC CALIBR | LPOSC CALIBF | LPOSC IRQR | LPOSC IRQF | LPOSC FAST | LPOSC ENA | Low Power Oscillator Configuration               |
| 31  | LPOSCSTATUS | R  |  | —        | —                | —                 | —            | —            | —          | LPOSC IRQ  | LPOSC EDGE |           | Low Power Oscillator Status                      |
| 312 | LPOSCFILT1  | RW |  | 00100000 | LPOSCFILT(15:8)  |                   |              |              |            |            |            |           | Low Power Oscillator Calibration Filter Constant |
| 313 | LPOSCFILT0  | RW |  | 11000100 | LPOSCFILT(7:0)   |                   |              |              |            |            |            |           | Low Power Oscillator Calibration Filter Constant |
| 314 | LPOSCREF1   | RW |  | 01100001 | LPOSCREF(15:8)   |                   |              |              |            |            |            |           | Low Power Oscillator Calibration Reference       |
| 315 | LPOSCREF0   | RW |  | 10101000 | LPOSCREF(7:0)    |                   |              |              |            |            |            |           | Low Power Oscillator Calibration Reference       |
| 316 | LPOSCFREQ1  | RW |  | 00000000 | LPOSCFREQ(9:2)   |                   |              |              |            |            |            |           | Low Power Oscillator Calibration Frequency       |
| 317 | LPOSCFREQ0  | RW |  | 0000—    | LPOSCFREQ(1:–2)  |                   |              |              | —          | —          | —          | —         | Low Power Oscillator Calibration Frequency       |
| 318 | LPOSCPER1   | RW |  | —        | LPOSCPER(15:8)   |                   |              |              |            |            |            |           | Low Power Oscillator Calibration Period          |
| 319 | LPOSCPER0   | RW |  | —        | LPOSCPER(7:0)    |                   |              |              |            |            |            |           | Low Power Oscillator Calibration Period          |

DAC

|     |           |    |   |          |               |            |   |                |               |  |  |  |                   |
|-----|-----------|----|---|----------|---------------|------------|---|----------------|---------------|--|--|--|-------------------|
| 330 | DACVALUE1 | RW | R | —0000    | —             | —          | — | DACVALUE(11:8) |               |  |  |  | DAC Value         |
| 331 | DACVALUE2 | RW | R | 00000000 | DACVALUE(7:0) |            |   |                |               |  |  |  | DAC Value         |
| 332 | DACCONFIG | RW | R | 00—0000  | DAC PWM       | DAC CLK X2 | — | —              | DACINPUT(3:0) |  |  |  | DAC Configuration |

APPLICATION INFORMATION

Typical Application Diagrams

Match to 50 Ω for Differential Antenna Pins  
(868 / 915 / 433 / 169 MHz RX / TX Operation)

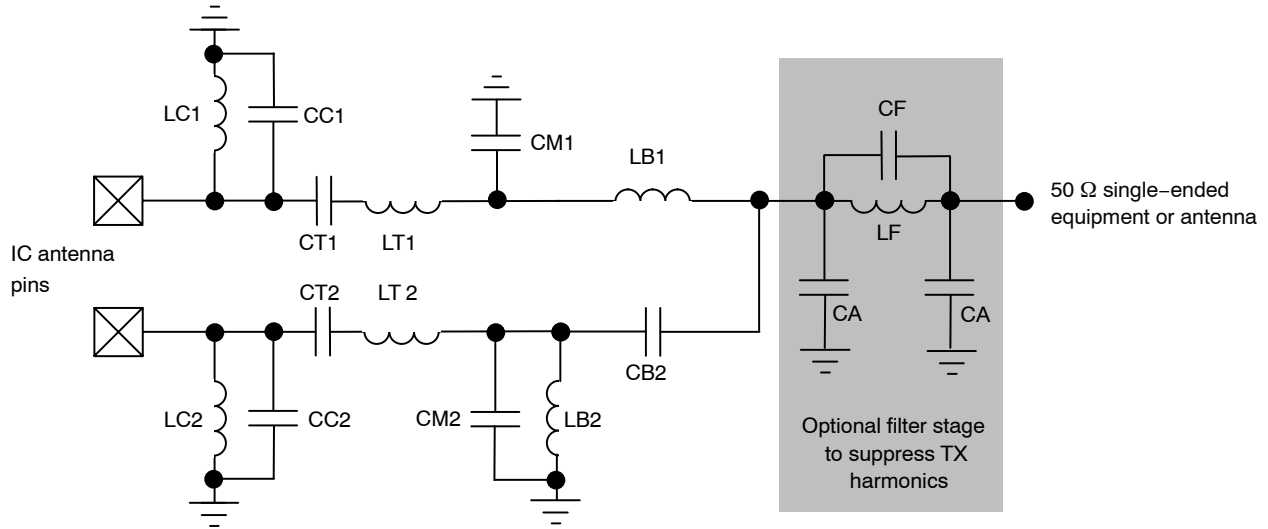

Figure 10. Structure of the Differential Antenna Interface for TX/RX Operation to 50 Ω Single-ended Equipment or Antenna

Table 29. TYPICAL COMPONENT VALUES

| Frequency Band | LC1,2 [nH] | CC1,2 [pF] | CT1,2 [pF] | LT1,2 [nH] | CM1 [pF] | CM2 [pF] | LB1,2 [nH] | CB2 [pF] | CF [pF] optional | LF [nH] optional | CA [pF] optional |
|----------------|------------|------------|------------|------------|----------|----------|------------|----------|------------------|------------------|------------------|
| 868 / 915 MHz  | 18         | nc         | 2.7        | 18         | 6.2      | 3.6      | 12         | 2.7      | nc               | 0 Ω              | nc               |
| 433 MHz        | 100        | nc         | 4.3        | 43         | 11       | 5.6      | 27         | 5.1      | nc               | 0 Ω              | nc               |
| 470 MHz        | 100        | nc         | 3.9        | 33         | 4.7      | nc       | 22         | 4.7      | nc               | 0 Ω              | nc               |
| 169 MHz        | 150        | 10         | 10         | 120        | 12       | nc       | 68         | 12       | 6.8              | 30               | 27               |

Match to 50 Ω for Single-ended Antenna Pin  
(868 / 915 / 433 MHz TX Operation)

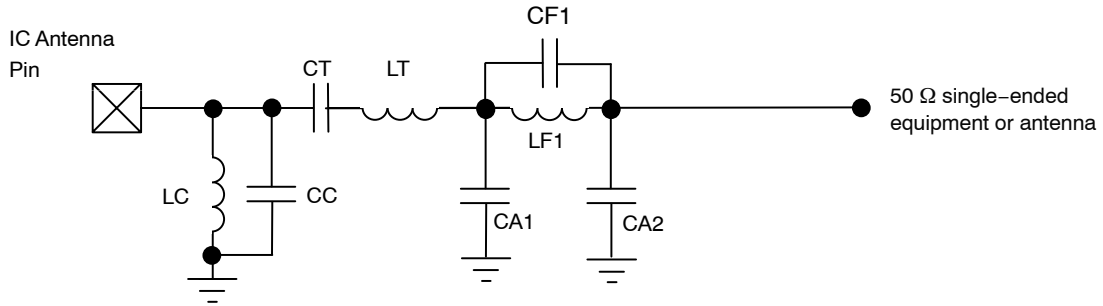

Figure 11. Structure of the Single-ended Antenna Interface for TX Operation to 50 Ω Single-ended Equipment or Antenna

Table 30. TYPICAL COMPONENT VALUES

| Frequency Band | LC [nH] | CC [pF] | CT [pF] | LT [nH] | CF1 [pF] | LF1 [nH] | CA1 [pF] | CA2 [pF] |
|----------------|---------|---------|---------|---------|----------|----------|----------|----------|
| 868 / 915 MHz  | 18      | nc      | 2.7     | 18      | 3.6      | 2.2      | 3.6      | nc       |
| 433 MHz        | 100     | nc      | 4.3     | 43      | 6.8      | 4.7      | 5.6      | nc       |

Match to 50 Ω for Single-ended Antenna Pin  
(169 MHz TX Operation)

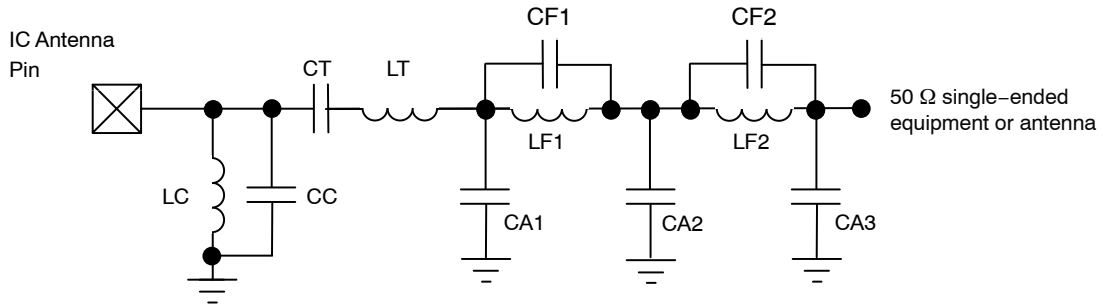

Figure 12. Structure of the Single-ended Antenna Interface for TX Operation to 50 Ω Single-ended Equipment or Antenna

Table 31. TYPICAL COMPONENT VALUES

| Frequency Band | LC [nH] | CC [pF] | CT [pF] | LT [nH] | CF1 [pF] | LF1 [nH] | CF2 [pF] | LF2 [nH] | CA1 [pF] | CA2 [pF] | CA3 [pF] |
|----------------|---------|---------|---------|---------|----------|----------|----------|----------|----------|----------|----------|
| 169 MHz        | 150     | 2.2     | 22      | 120     | 4.7      | 39       | 1.8      | 47       | 33       | 47       | 15       |

# AX5043

Using a Dipole Antenna and the Internal TX/RX Switch

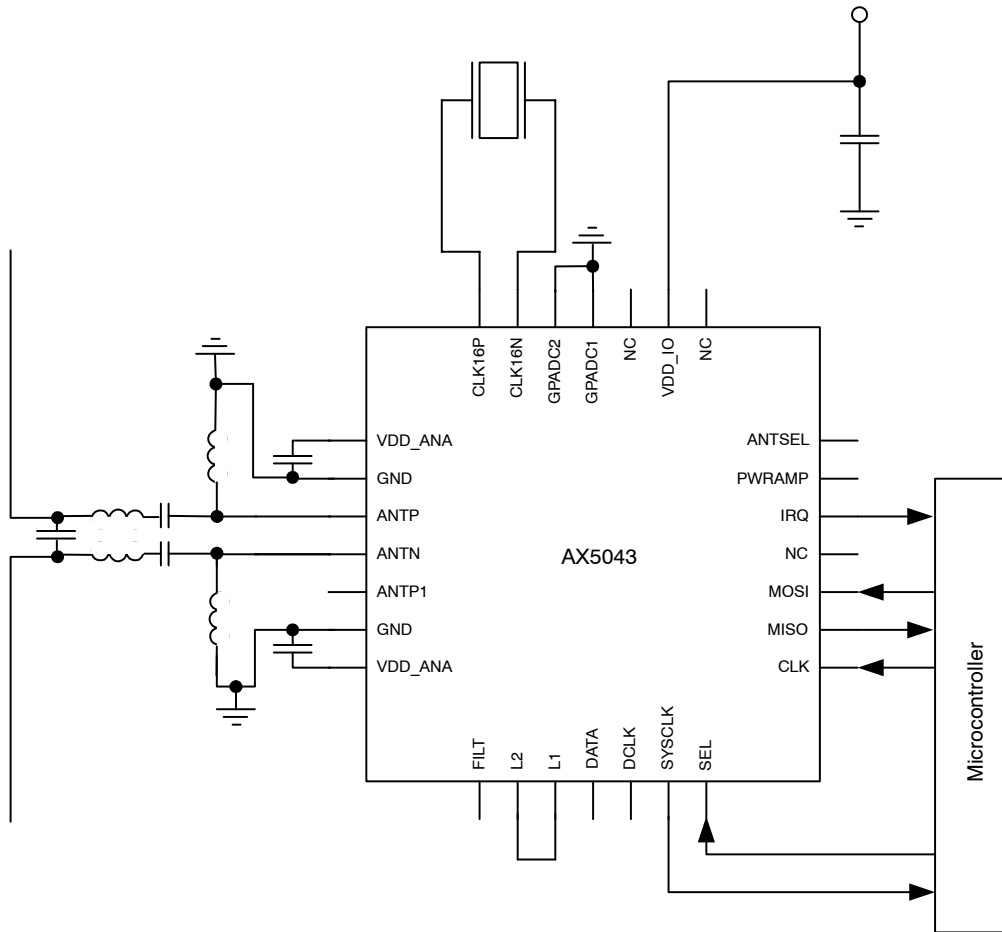

Figure 13. Typical Application Diagram with Dipole Antenna and Internal TX/RX Switch

# AX5043

Using a Single-ended Antenna and the Internal TX/RX Switch

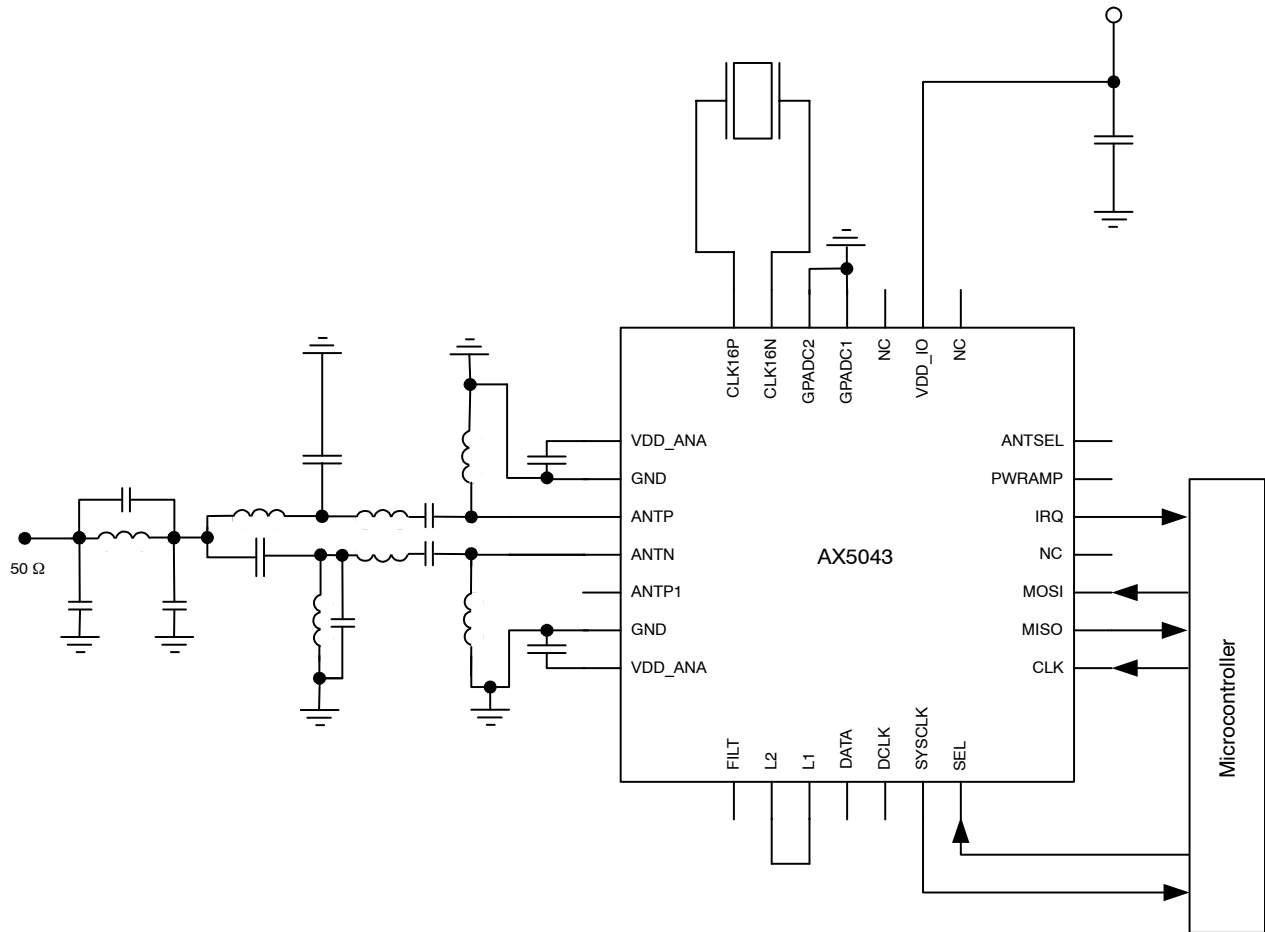

Figure 14. Typical Application Diagram with Single-ended Antenna and Internal TX/RX Switch

# AX5043

Using an External High-power PA and an External TX/RX Switch

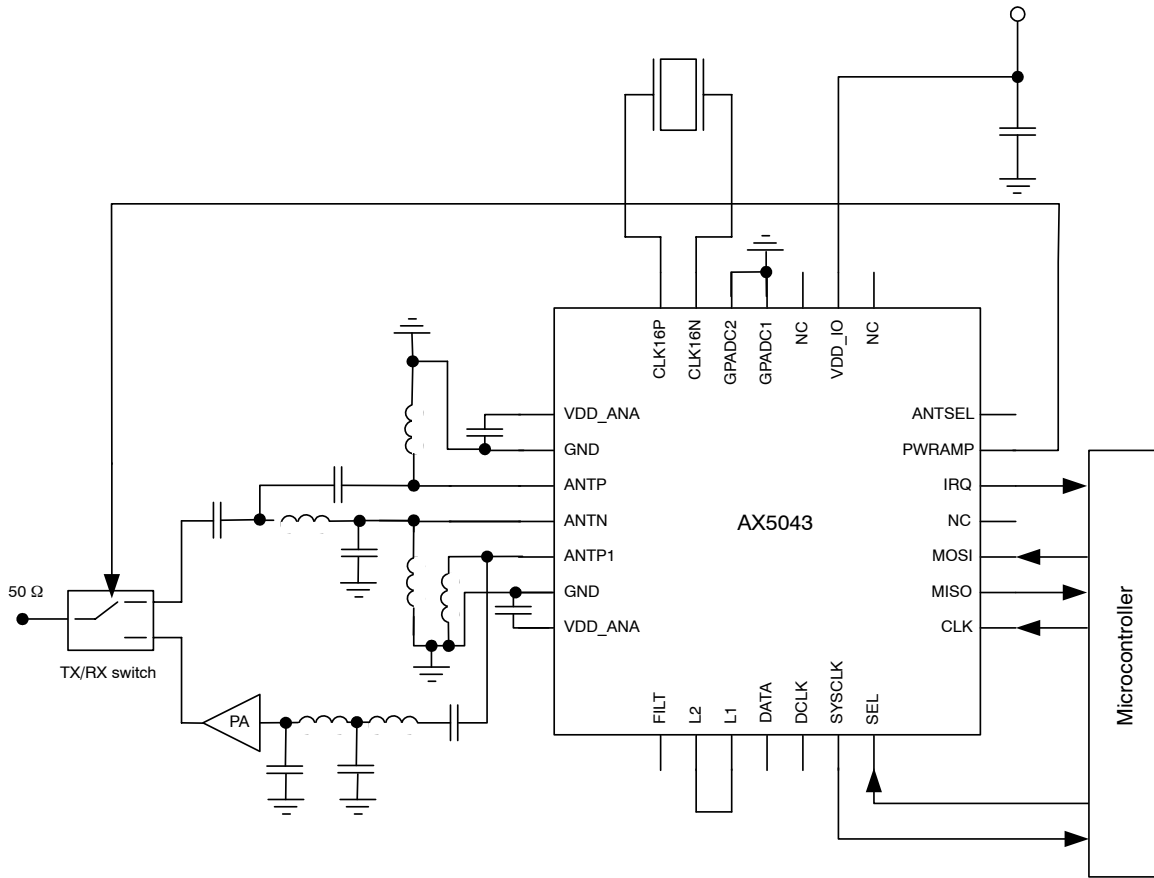
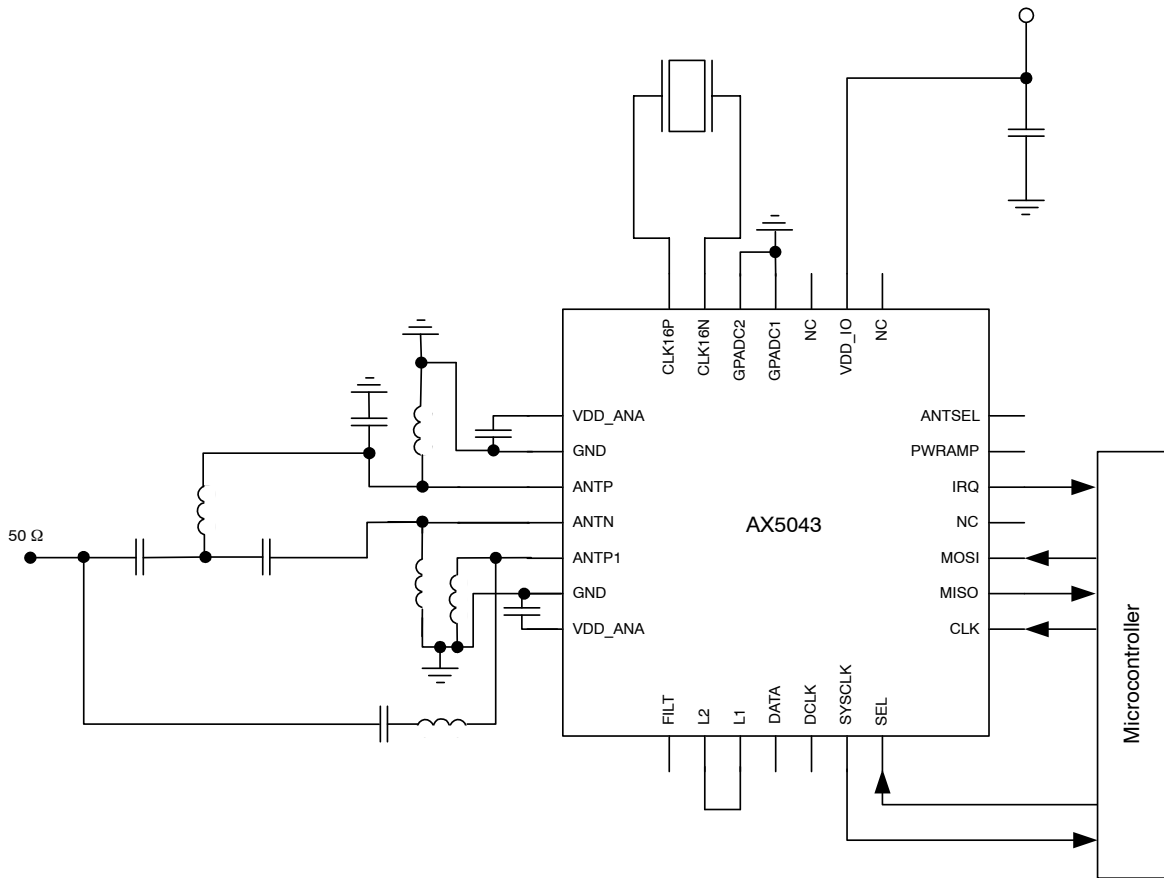

Figure 15. Typical Application Diagram with Single-ended Antenna, External PA and External Antenna Switch

# AX5043

Using the Single-ended PA



**Figure 16. Typical Application Diagram with Single-ended Antenna, Single-ended Internal PA, without RX/TX Switch**

NOTE: For details and recommendations on implementing this configuration refer to the AX5043 Application Note: 0 dBm / 8 mA TX and 9.5 mA RX Configuration for the 868 MHz Band.

# AX5043

## Using Two Antenna

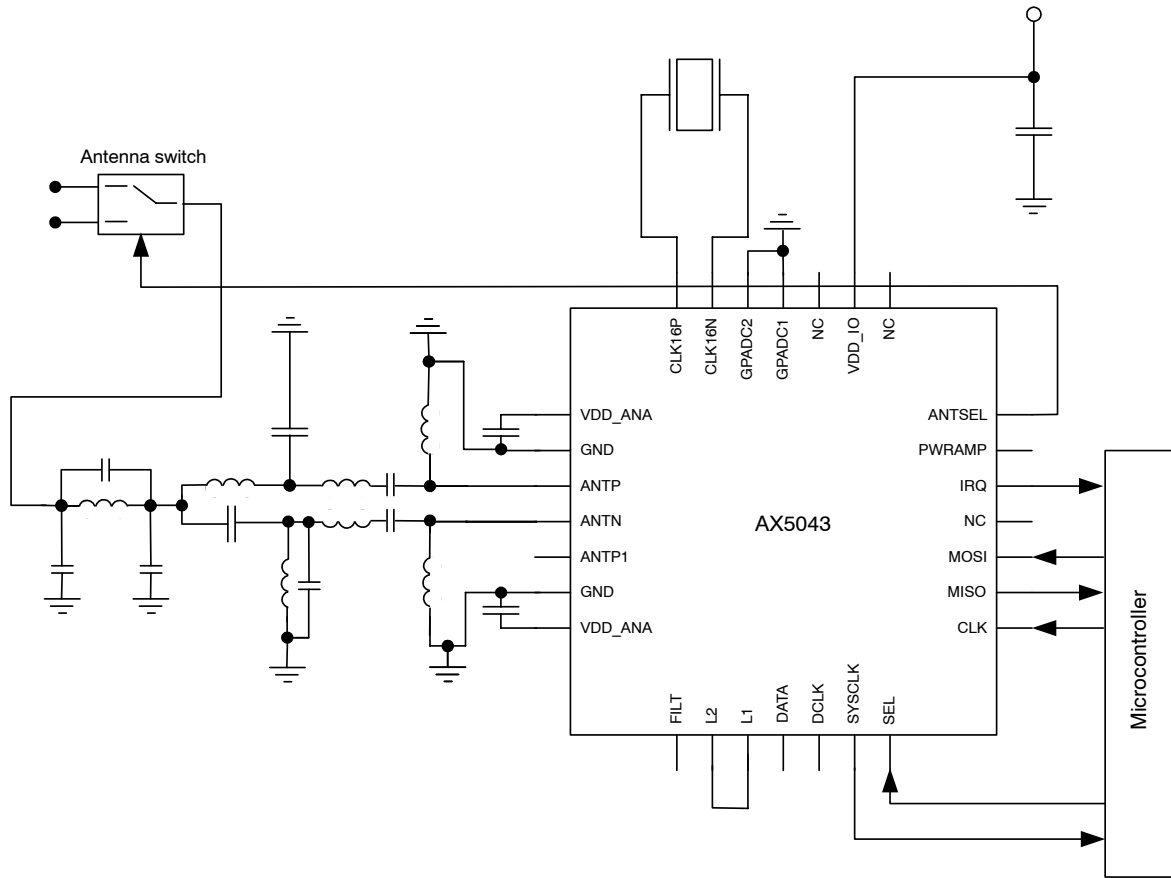

Figure 17. Typical Application Diagram with Two Single-ended Antenna and External Antenna Switch



# AX5043

Using an External VCO Inductor

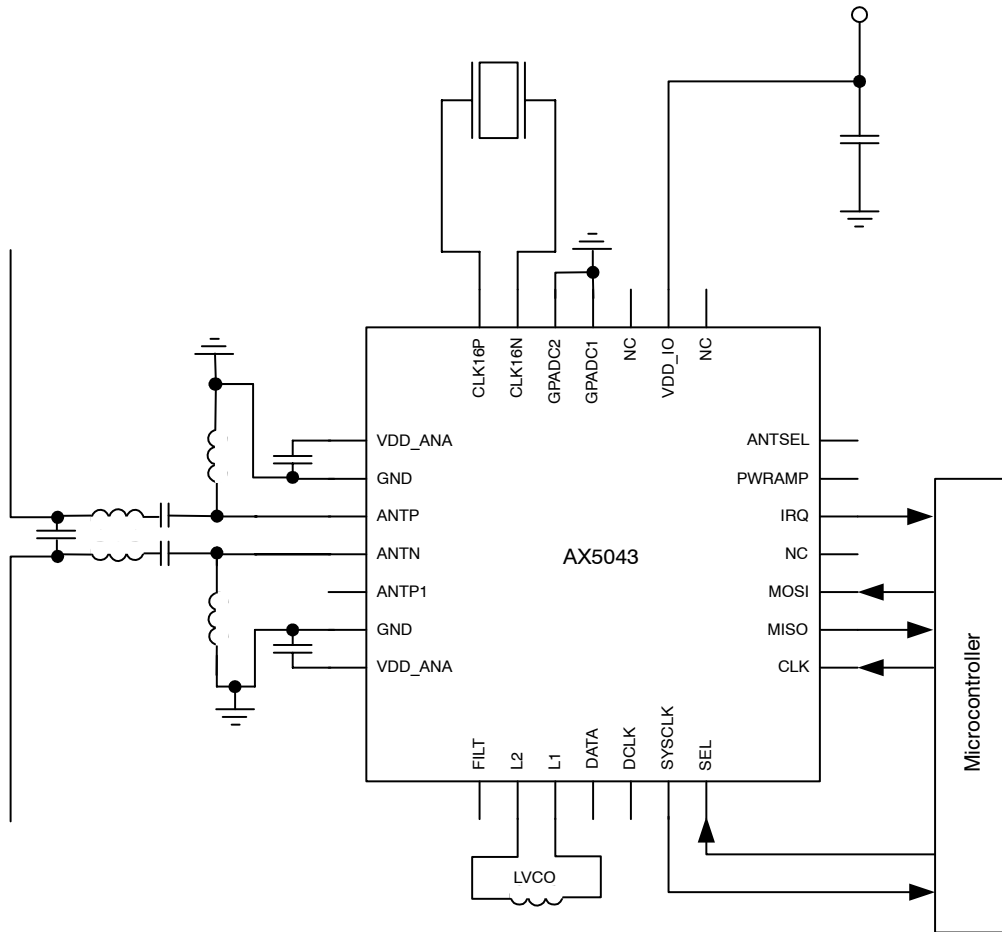

Figure 18. Typical Application Diagram with External VCO Inductor

# AX5043

Using an External VCO

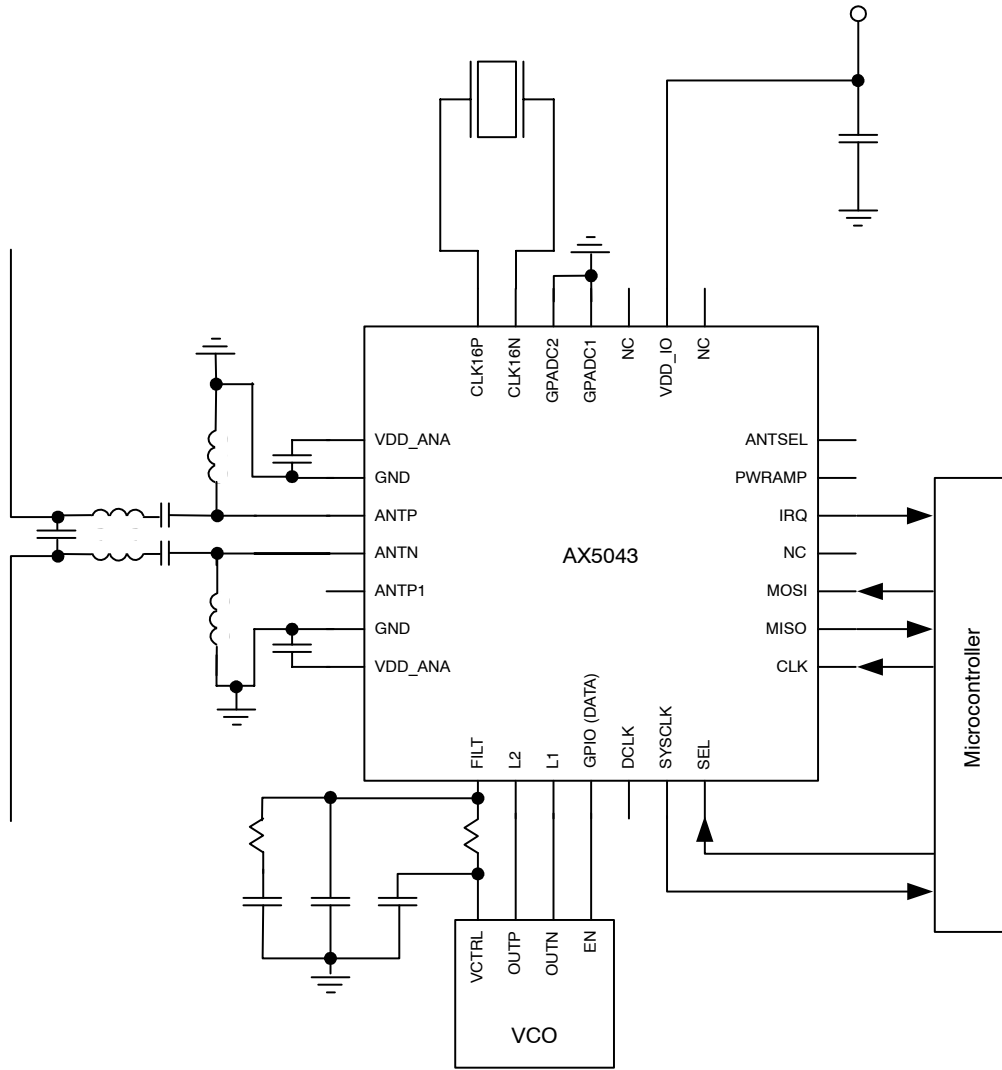
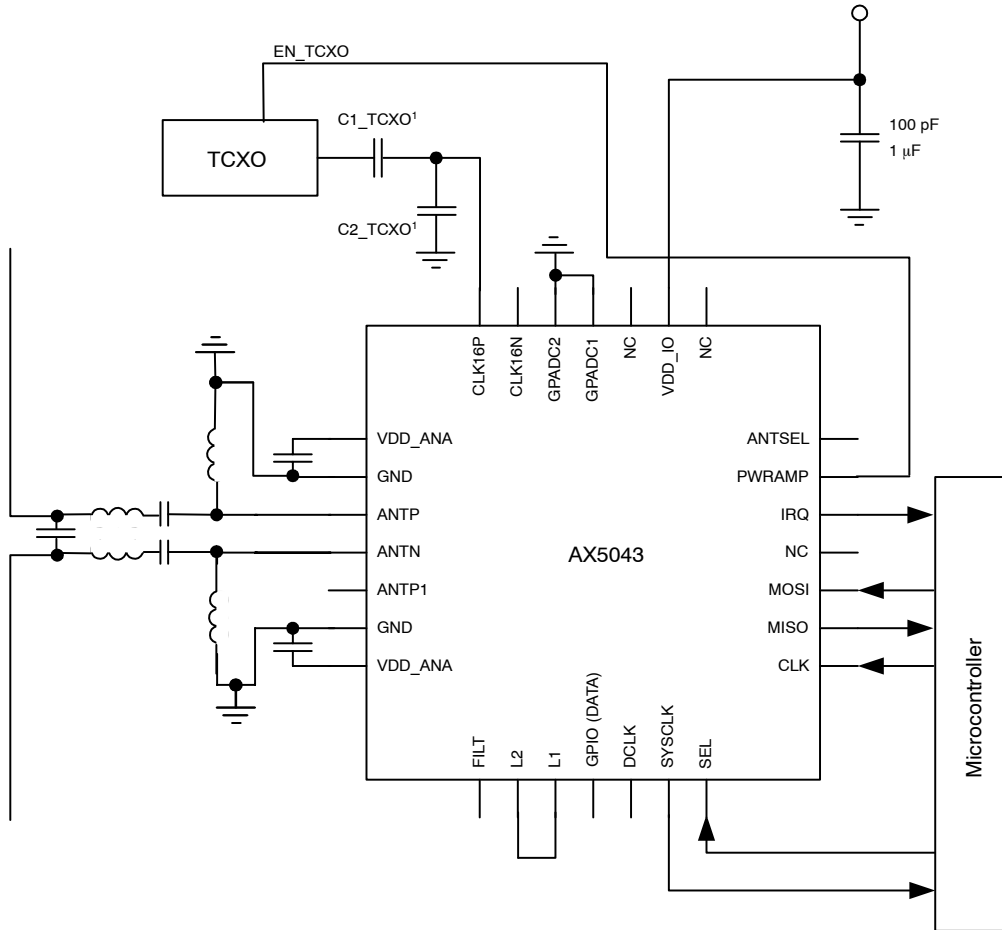

Figure 19. Typical Application Diagram with External VCO

# AX5043

Using a TCXO



Note 1: For detailed TCXO network recommendations depending on TCXO output swing refer to the AX5043 Application Note: Use with a TCXO Reference Clock.

Figure 20. Typical Application Diagram with a TCXO

# AX5043

## QFN28 PACKAGE INFORMATION

### Package Outline QFN28 5 mm x 5 mm

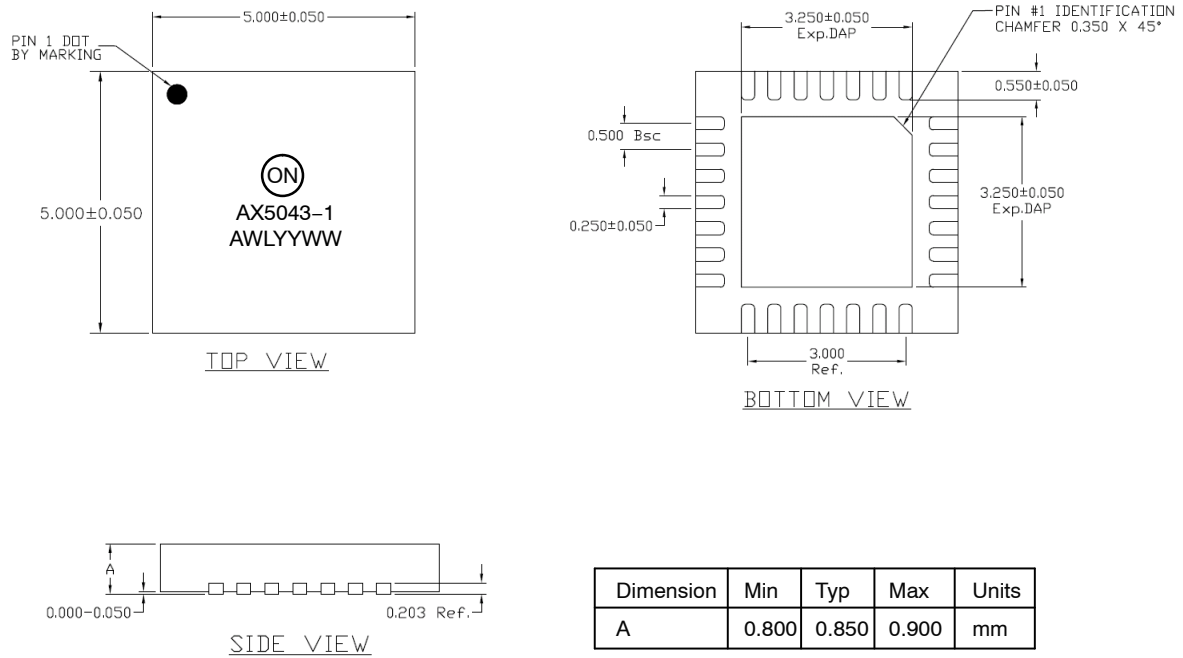

#### NOTES:

1. JEDEC ref MO-220
2. All dimensions are in millimeters
3. Pin 1 is identified by chamfer on corner of exposed die pad
4. Package warp is 0.050 maximum
5. Coplanarity applies to the exposed pad as well as the terminal
6. AWLYYWW is the packaging lot code
7. RoHS

**Figure 21. Package Outline QFN28 5 mm x 5 mm**

QFN28 Soldering Profile

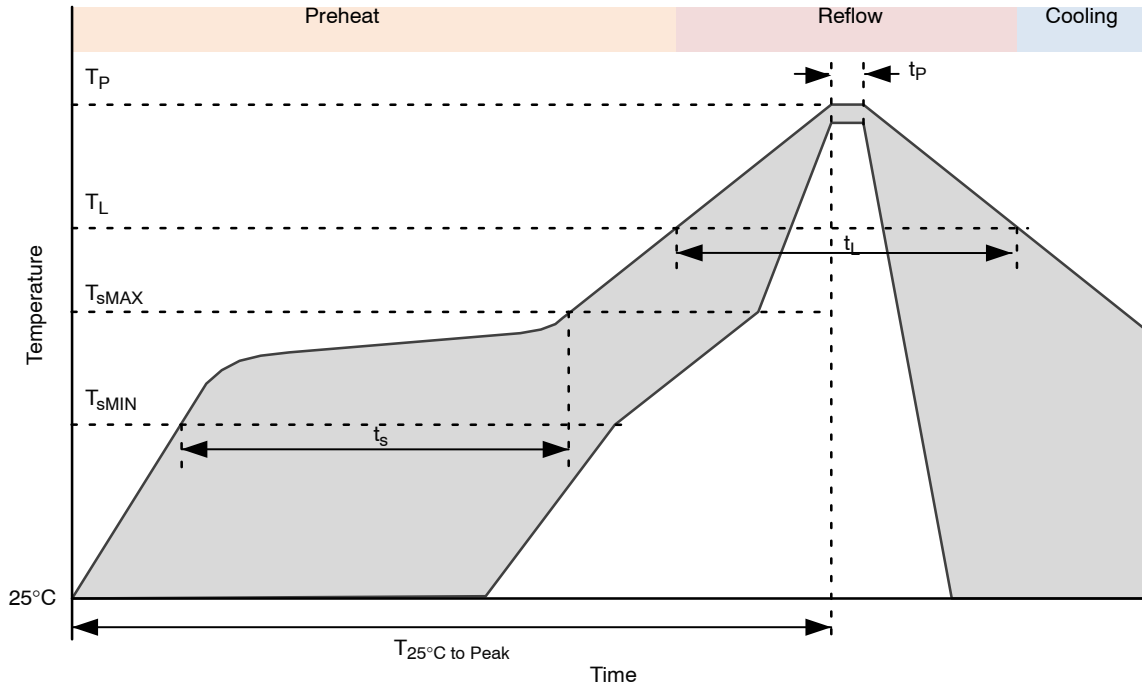

Figure 22. QFN40 Soldering Profile

Table 32.

| Profile Feature                            | Pb-Free Process                          |
|--|--|
| Average Ramp-Up Rate                       | 3°C/s max.                               |
| Preheat Preheat                            |  |
| Temperature Min                            | $T_{sMIN}$<br>150°C                      |
| Temperature Max                            | $T_{sMAX}$<br>200°C                      |
| Time ( $T_{sMIN}$ to $T_{sMAX}$ )          | $t_s$<br>60 – 180 sec                    |
| Time 25°C to Peak Temperature              | $T_{25°C \text{ to Peak}}$<br>8 min max. |
| Reflow Phase                               |  |
| Liquidus Temperature                       | $T_L$<br>217°C                           |
| Time over Liquidus Temperature             | $t_L$<br>60 – 150 s                      |
| Peak Temperature                           | $t_p$<br>260°C                           |
| Time within 5°C of actual Peak Temperature | $T_p$<br>20 – 40 s                       |
| Cooling Phase                              |  |
| Ramp-down rate                             | 6°C/s max.                               |

1. All temperatures refer to the top side of the package, measured on the the package body surface.

**QFN28 Recommended Pad Layout**

1. PCB land and solder masking recommendations are shown in Figure 23.

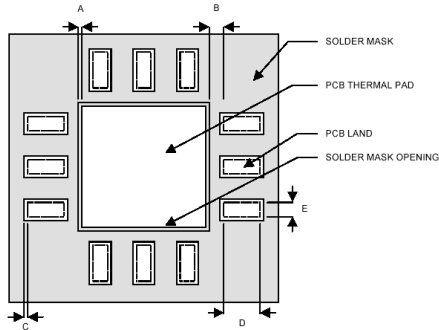

- A = Clearance from PCB thermal pad to solder mask opening, 0.0635 mm minimum
- B = Clearance from edge of PCB thermal pad to PCB land, 0.2 mm minimum
- C = Clearance from PCB land edge to solder mask opening to be as tight as possible to ensure that some solder mask remains between PCB pads.
- D = PCB land length = QFN solder pad length + 0.1 mm
- E = PCB land width = QFN solder pad width + 0.1 mm

**Figure 23. PCB Land and Solder Mask Recommendations**

- 2. Thermal vias should be used on the PCB thermal pad (middle ground pad) to improve thermal conductivity from the device to a copper ground plane area on the reverse side of the printed circuit board. The number of vias depends on the package thermal requirements, as determined by thermal simulation or actual testing.
- 3. Increasing the number of vias through the printed circuit board will improve the thermal conductivity to the reverse side ground plane and external heat sink. In general, adding more metal through the PCB under the IC will improve operational heat transfer, but will require careful attention to uniform heating of the board during assembly.

**Assembly Process**

*Stencil Design & Solder Paste Application*

- 1. Stainless steel stencils are recommended for solder paste application.
- 2. A stencil thickness of 0.125 – 0.150 mm (5 – 6 mils) is recommended for screening.

- 3. For the PCB thermal pad, solder paste should be printed on the PCB by designing a stencil with an array of smaller openings that sum to 50% of the QFN exposed pad area. Solder paste should be applied through an array of squares (or circles) as shown in Figure 24.
- 4. The aperture opening for the signal pads should be between 50–80% of the QFN pad area as shown in Figure 25.
- 5. Optionally, for better solder paste release, the aperture walls should be trapezoidal and the corners rounded.
- 6. The fine pitch of the IC leads requires accurate alignment of the stencil and the printed circuit board. The stencil and printed circuit assembly should be aligned to within + 1 mil prior to application of the solder paste.
- 7. No-clean flux is recommended since flux from underneath the thermal pad will be difficult to clean if water-soluble flux is used.

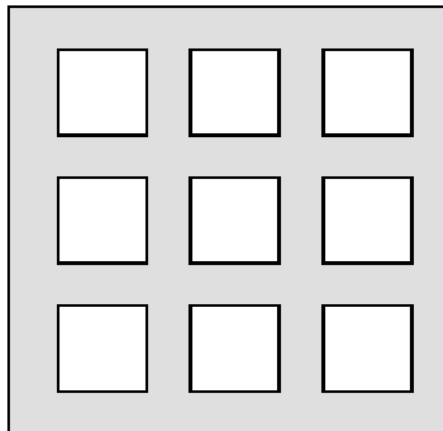

**Figure 24. Solder Paste Application on Exposed Pad**

# AX5043

Minimum 50% coverage

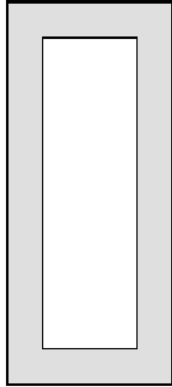

62% coverage

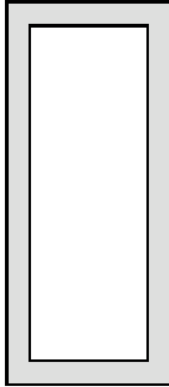

Maximum 80% coverage

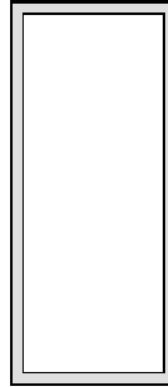

Figure 25. Solder Paste Application on Pins

## Life Support Applications

This product is not designed for use in life support appliances, devices, or in systems where malfunction of this product can reasonably be expected to result in personal injury. AXSEM customers using or selling this product for

use in such applications do so at their own risk and agree to fully indemnify AXSEM for any damages resulting from such improper use or sale.

**onsemi, Onsemi**, and other names, marks, and brands are registered and/or common law trademarks of Semiconductor Components Industries, LLC dba "onsemi" or its affiliates and/or subsidiaries in the United States and/or other countries. onsemi owns the rights to a number of patents, trademarks, copyrights, trade secrets, and other intellectual property. A listing of onsemi's product/patent coverage may be accessed at [www.onsemi.com/site/pdf/Patent-Marking.pdf](http://www.onsemi.com/site/pdf/Patent-Marking.pdf). onsemi reserves the right to make changes at any time to any products or information herein, without notice. The information herein is provided "as-is" and onsemi makes no warranty, representation or guarantee regarding the accuracy of the information, product features, availability, functionality, or suitability of its products for any particular purpose, nor does onsemi assume any liability arising out of the application or use of any product or circuit, and specifically disclaims any and all liability, including without limitation special, consequential or incidental damages. Buyer is responsible for its products and applications using onsemi products, including compliance with all laws, regulations and safety requirements or standards, regardless of any support or applications information provided by onsemi. "Typical" parameters which may be provided in onsemi data sheets and/or specifications can and do vary in different applications and actual performance may vary over time. All operating parameters, including "Typicals" must be validated for each customer application by customer's technical experts. onsemi does not convey any license under any of its intellectual property rights nor the rights of others. onsemi products are not designed, intended, or authorized for use as a critical component in life support systems or any FDA Class 3 medical devices or medical devices with a same or similar classification in a foreign jurisdiction or any devices intended for implantation in the human body. Should Buyer purchase or use onsemi products for any such unintended or unauthorized application, Buyer shall indemnify and hold onsemi and its officers, employees, subsidiaries, affiliates, and distributors harmless against all claims, costs, damages, and expenses, and reasonable attorney fees arising out of, directly or indirectly, any claim of personal injury or death associated with such unintended or unauthorized use, even if such claim alleges that onsemi was negligent regarding the design or manufacture of the part. onsemi is an Equal Opportunity/Affirmative Action Employer. This literature is subject to all applicable copyright laws and is not for resale in any manner.

## PUBLICATION ORDERING INFORMATION

LITERATURE FULFILLMENT:  
Email Requests to: [orderlit@onsemi.com](mailto:orderlit@onsemi.com)

onsemi Website: [www.onsemi.com](http://www.onsemi.com)

TECHNICAL SUPPORT  
North American Technical Support:  
Voice Mail: 1 800-282-9855 Toll Free USA/Canada  
Phone: 011 421 33 790 2910

Europe, Middle East and Africa Technical Support:  
Phone: 00421 33 790 2910  
For additional information, please contact your local Sales Representative

## X-ON Electronics

Largest Supplier of Electrical and Electronic Components

*Click to view similar products for [RF Transceiver](#) category:*

*Click to view products by [ON Semiconductor](#) manufacturer:*

Other Similar products are found below :

[ADRV9026BBCZ](#) [ADRV9026-MB/PCBZ](#) [ADL6316ACCZ](#) [ADL6316ACCZ-R7](#) [ADL6317ACCZ](#) [SYN480R](#) [VI4455](#) [NRF51822-CEAA-R\(E0\)](#) [ADF7242BCPZ-RL](#) [AT86RF232-ZX](#) [ADF7021-NBCPZ-RL](#) [Si4055-C2A-GM](#) [ADRV9008BBCZ-2](#) [ADF7030-1BSTZN-RL](#) [AD9874ABSTRL](#) [ADF7020-1BCPZ-RL7](#) [ADF7020BCPZ](#) [ADF7020BCPZ-RL](#) [ADF7021BCPZ](#) [ADF7021BCPZ-RL](#) [ADF7021BCPZ-RL7](#) [ADF7021-NBCPZ](#) [ADF7021-VBCPZ](#) [ADF7023-JBCPZ](#) [ADF7025BCPZ](#) [ADF7241BCPZ](#) [ADRV9029BBCZ](#) [AT86RF231-ZU](#) [AT86RF232-ZXR](#) [AT86RF233-ZU](#) [ATA8520-GHQW](#) [FM11NC08S](#) [MC3361BPL-D16-T](#) [SX1236IMLTRT](#) [HT9170D](#) [BGT 24MTR11 E6327](#) [BGT24MTR11E6327XUMA1](#) [BGT24MTR12E6327XUMA1](#) [MAX2510EEI+](#) [MAX2511EEI+](#) [MAX2510EEI+T](#) [MAX2832ETM+](#) [MAX7030LATJ+](#) [SX1212IWLTRT](#) [MAX9947ETE+](#) [AT86RF212B-ZU](#) [AT86RF231-ZUR](#) [ATA5429-PLSW](#) [NRF24LE1-O17Q32-R](#) [AT86RF233-ZUR](#)