

Bluetooth® 5 Radio System-on-Chip (SoC)

RSL10

Introduction

RSL10 is an ultra-low-power, highly flexible multi-protocol 2.4 GHz radio specifically designed for use in high-performance wearable and medical applications. With its Arm® Cortex®-M3 Processor and LPDSP32 DSP core, RSL10 supports Bluetooth low energy technology and 2.4 GHz proprietary protocol stacks, without sacrificing power consumption.

Key Features

- Rx Sensitivity (Bluetooth Low Energy Mode, 1 Mbps): -94 dBm
- Data Rate: 62.5 to 2000 kbps
- Transmitting Power: -17 to +6 dBm
- Peak Rx Current = 5.6 mA (1.25 V VBAT)
- Peak Rx Current = 3.0 mA (3 V VBAT)
- Peak Tx Current (0 dBm) = 8.9 mA (1.25 V VBAT)
- Peak Tx Current (0 dBm) = 4.6 mA (3 V VBAT)
- Bluetooth 5 Certified
- Support for Bluetooth 5 features: LE 2-Mbit PHY (High Speed), as well as backwards compatibility and support for earlier Bluetooth Low Energy specifications
- Arm Cortex-M3 Processor Clocked at up to 48 MHz
- LPDSP32 for Audio Codec
- Supply Voltage Range: 1.1 – 3.3 V
- Current Consumption (1.25 V VBAT):
 - ◆ Deep Sleep, IO Wake-up: 50 nA
 - ◆ Deep Sleep, 8 kB RAM Retention: 300 nA
 - ◆ Audio Streaming at 7 kHz Audio BW: 1.8 mA RX, 1.8 mA TX
- Current Consumption (3 V VBAT):
 - ◆ Deep Sleep, IO Wake-up: 25 nA
 - ◆ Deep Sleep, 8 kB RAM Retention: 100 nA
 - ◆ Audio Streaming at 7 kHz Audio BW: 0.9 mA RX, 0.9 mA TX
- 384 kB of Flash Memory
- Highly-integrated System-on-Chip (SoC)
- Supports FOTA (Firmware Over-The-Air) Updates

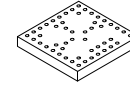

WLCSP51
CASE 567MT

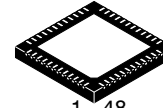

QFN48
CASE 485BA

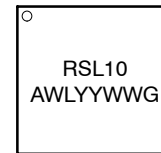

(QFN48)

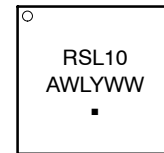

(WLCSP51)

XXXXXX = Specific Device Code
A = Assembly Location
WL = Wafer Lot
Y or YY = Year
WW = Work Week
G or ■ = Pb-Free Package

ORDERING INFORMATION

Device	Package	Shipping†
NCH-RSL10-101WC51-ABG	WLCSP51 (Pb-Free)	5000 / Tape & Reel
NCH-RSL10-101Q48-ABG	QFN48 (Pb-Free)	3000 / Tape & Reel

†For information on tape and reel specifications, including part orientation and tape sizes, please refer to our Tape and Reel Packaging Specification Brochure, BRD8011/D.

RSL10

FEATURES

- **Arm Cortex–M3 Processor:** A 32–bit core for real–time applications, specifically developed to enable high–performance low–cost platforms for a broad range of low–power applications.
- **LPDSP32:** A 32–bit Dual Harvard DSP core that efficiently supports audio codecs required for wireless audio communication. Various codecs are available to customers through libraries that are included in RSL10’s development tools.
- **Radio Frequency Front–End:** Based on a 2.4 GHz RF transceiver, the RFFE implements the physical layer of the Bluetooth low energy technology standard and other proprietary or custom protocols.
- **Protocol Baseband Hardware:** Bluetooth 5 certified and includes support for a 2 Mbps RF link and custom protocol options. The RSL10 baseband stack is supplemented by support structures that enable implementation of **onsemi** and customer designed custom protocols.
- **Highly–Integrated SoC:** The dual–core architecture is complemented by high–efficiency power management units, oscillators, flash and RAM memories, a DMA controller, along with a full complement of peripherals and interfaces.
- **Deep Sleep Mode:** RSL10 can be put into a Deep Sleep Mode when no operations are required. Various Deep Sleep Mode configurations are available, including:
 - ◆ “IO wake–up” configuration. The power consumption in deep sleep mode is 50 nA (1.25 V VBAT).
 - ◆ Embedded 32 kHz oscillator running with interrupts from timer or external pin. The total current drain is 90 nA (1.25 V VBAT).
 - ◆ As above with 8 kB RAM data retention. The total current drain is 300 nA (1.25 V VBAT).
 - ◆ The DC–DC converter can be used in buck mode or LDO mode during Sleep Mode, depending on VBAT voltage.
- **Standby Mode:** Can be used to reduce the average power consumption for off–duty cycle operation, ranging typically from a few ms to a few hundreds of ms. The typical chip power consumption is 30 μ A in Standby Mode.
- **Multi–Protocol Support:** Using the flexibility provided by LPDSP32, the Arm Cortex–M3 processor, and the RF front–end; proprietary protocols and other custom protocols are supported.
- **Flexible Supply Voltage:** RSL10 integrates high–efficiency power regulators and has a VBAT range of 1.1 to 3.3 V. See Table 2. RECOMMENDED OPERATING CONDITIONS.
- **Highly Configurable Interfaces:** I²C, UART, two SPI interfaces, PCM interface, multiple GPIOs. It also supports a digital microphone interface (DMIC) and an output driver (OD).
- **The Asynchronous Sample Rate Converter (ASRC) Block and Audio Sink Clock Blocks:** Provides a means of synchronizing the audio sample rate between an audio source and an audio sink. The audio sink clock also provides a high accuracy mechanism to measure an input clock used for the RTC or protocol timing.
- **Flexible Clocking Scheme:** RSL10 must be clocked from the XTAL/PLL of the radio front–end at 48 MHz when transmitting or receiving RF traffic. When RSL10 is not transmitting/receiving RF traffic, it can run off the 48 MHz XTAL, the internal RC oscillators, the 32 kHz oscillator, or an external clock. A low frequency RTC clock at 32 kHz can also be used in Deep Sleep Mode. It can be sourced from either the internal XTAL, the RC oscillator, or a digital input pad.
- **Diverse Memory Architecture:** 76 kB of SRAM program memory (4 kB of which is PROM containing the chip boot–up program, and is thus unavailable to the user) and 88 kB of SRAM data memory are available. A total of 384 kB of flash is available to store the Bluetooth stack and other applications. The Arm Cortex–M3 processor can execute from SRAM and/or flash.
- **Security:** AES128 encryption hardware block for custom secure algorithms and code protection with authenticated debug port access (JTAG ‘lock’)
- **Ultra–Low Power Consumption Application Examples:**
 - ◆ **Audio Signal Streaming:** IDD = 1.8 mA @ VBAT 1.25 V in Rx Mode for receiving, decoding and sending an 7 kHz bandwidth audio signal to the SPI interface using a proprietary custom audio protocol from **onsemi**.
 - ◆ **Low Duty Cycle Advertising:** IDD 1.1 μ A for advertising at all three channels at 5 second intervals @ VBAT 3 V, DCDC converter enabled.
- **RoHS Compliant Device**

RSL10

RSL10 INTERNAL BLOCK DIAGRAM

The block diagram of the RSL10 chip is shown in Figure 1.

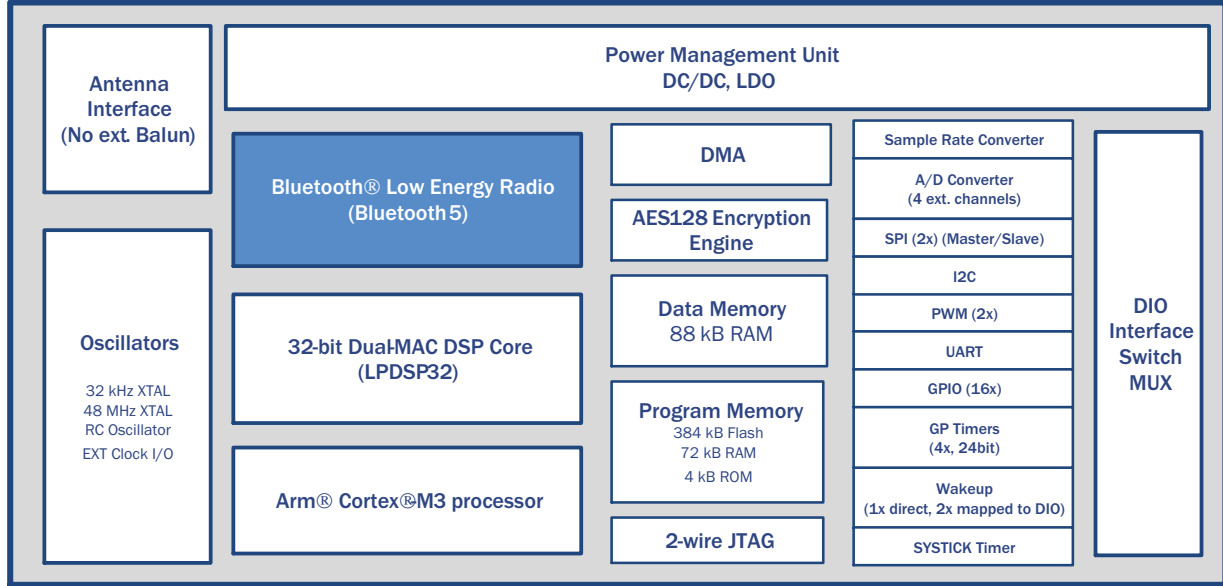

Figure 1. RSL10 Block Diagram

Table 1. ABSOLUTE MAXIMUM RATINGS

Symbol	Parameter	Min	Max	Unit
V _{BAT}	Power Supply Voltage		3.63	V
V _{DDO}	I/O Supply Voltage (Notes 1 and 3)		3.63	V
V _{SSRF}	RF Front-end Ground	-0.3		V
V _{SSA}	Analog Ground	-0.3		V
V _{SSD}	Digital Core and I/O Ground	-0.3		V
V _{in}	Voltage at Any Input Pin	V _{SSD} -0.3	V _{DDO} + 0.3 (Note 2)	V
T _{functional}	Functional Temperature Range	-40	85	°C
T _{storage}	Storage Temperature Range	-40	85	°C

Caution: Class 2 ESD Sensitivity, JESD22-A114-B (2000 V)
The QFN package meets 450 V CDM level

Stresses exceeding those listed in the Maximum Ratings table may damage the device. If any of these limits are exceeded, device functionality should not be assumed, damage may occur and reliability may be affected.

- V_{DDO} voltage must not be applied before V_{BAT} voltage on cold start.
- Up to a maximum of 3.63 V.
- For applications where V_{BAT} and V_{DDO} are connected externally (typical connection approach) there is an initial, small power surge during V_{BAT} rise, i.e. cold start of RSL10. This power surge corresponds to:
 - 900 μC max @ V_{BAT} = 3 V
 - 240 μC max @ V_{BAT} = 1.5 V
 - 180 μC max @ V_{BAT} = 1.25 V

The power surge can be prevented if there is a minimum delay of 5 ms between the supply voltage reaching 1 V on the V_{BAT} pin, and the supply voltage reaching 1 V on the V_{DDO} pin. This assumes a 4.7 μF capacitor on V_{CC}.

RSL10

Table 2. RECOMMENDED OPERATING CONDITIONS

Description	Symbol	Conditions	Min	Typ	Max	Units
Supply Voltage Operating Range	VBAT	Input supply voltage on VBAT pin (Note 4)	1.18	1.25	3.3	V

Functional operation above the stresses listed in the Recommended Operating Ranges is not implied. Extended exposure to stresses beyond the Recommended Operating Ranges limits may affect device reliability.

4. In order to be able to use a VBAT Min of 1.1 V, the following reduced operating conditions should be observed:

- Maximum Tx power 0 dBm.
- SYSCLK \leq 24 MHz.
- Functional temperature range limited to 0–50 °C

The following trimming parameters should be used:

- VCC = 1.10 V
- VDDC = 0.92 V
- VDDM = 1.05 V, will be limited by VCC at end of battery life
- VDDRF = 1.05 V, will be limited by VCC at end of battery life. VDDPA should be disabled

RSL10 should enter in end-of-battery-life operating mode if VCC falls below 1.03 V. VCC will remain above 1.03 V if VBAT \geq 1.10 V under the restricted operating conditions described above.

Table 3. ELECTRICAL PERFORMANCE SPECIFICATIONS

Unless otherwise noted, the specifications mentioned in the table below are valid at 25°C for VBAT = VDDO = 1.25 V in LDO mode, or VBAT = VDDO = 3 V in DC-DC (buck) mode.

Description	Symbol	Conditions	Min	Typ	Max	Units
-------------	--------	------------	-----	-----	-----	-------

OVERALL

Current consumption RX, VBAT = 1.25 V, low latency	I _{VBAT}	RX Mode, onsemi proprietary audio streaming protocol at 7 kHz audio BW, 5.5 ms delay.		1.8		mA
Current consumption TX, VBAT = 1.25 V, low latency	I _{VBAT}	TX Mode, onsemi proprietary audio streaming protocol at 7 kHz audio BW, 5.5 ms delay. Transmit power: 0 dBm		1.8		mA
Current consumption RX, VBAT = 1.25 V	I _{VBAT}	RX Mode, onsemi proprietary audio streaming protocol at 7 kHz audio BW, 37 ms delay.		1.15		mA
Deep sleep current, example 1, VBAT = 1.25 V	I _{ds1}	Wake up from wake up pin or DIO wake up.		50		nA
Deep sleep current, example 2, VBAT = 1.25 V	I _{ds2}	Embedded 32 kHz oscillator running with interrupts from timer or external pin.		90		nA
Deep sleep current, example 3, VBAT = 1.25 V	I _{ds3}	As I _{ds2} but with 8 kB RAM data retention.		300		nA
Standby Mode current, VBAT = 1.25 V	I _{stb}	Digital blocks and memories are not clocked and are powered at a reduced voltage.		30		μA
Current consumption RX, VBAT = 3 V	I _{VBAT}	RX Mode, onsemi proprietary audio streaming protocol at 7 kHz audio BW, 5.5 ms delay.		0.9		mA
Current consumption TX, VBAT = 3 V	I _{VBAT}	TX Mode, onsemi proprietary audio streaming protocol at 7 kHz audio BW, 5.5 ms delay. Transmit power: 0 dBm		0.9		mA
Deep sleep current, example 1, VBAT = 3 V	I _{ds1}	Wake up from wake up pin or DIO wake up.		25		nA
Deep sleep current, example 2, VBAT = 3 V	I _{ds2}	Embedded 32 kHz oscillator running with interrupts from timer or external pin.		40		nA
Deep sleep current, example 3, VBAT = 3 V	I _{ds3}	As I _{ds2} but with 8 kB RAM data retention.		100		nA
Standby Mode current, VBAT = 3 V	I _{stb}	Digital blocks and memories are not clocked and are powered at a reduced voltage.		17		μA

EEMBC ULPMark BENCHMARK, CORE PROFILE

ULPMark CP 3.0 V		Arm Cortex-M3 processor running from RAM, VBAT= 3.0 V, IAR C/C++ Compiler for ARM 8.20.1.14183		1090		ULP Mark
------------------	--	--	--	------	--	----------

RSL10

Table 3. ELECTRICAL PERFORMANCE SPECIFICATIONS (continued)

Unless otherwise noted, the specifications mentioned in the table below are valid at 25°C for VBAT = VDDO = 1.25 V in LDO mode, or VBAT = VDDO = 3 V in DC-DC (buck) mode.

Description	Symbol	Conditions	Min	Typ	Max	Units
EEMBC ULPMark BENCHMARK, CORE PROFILE						
ULPMark CP 2.1 V		Arm Cortex-M3 processor running from RAM, VBAT = 2.1 V, IAR C/C++ Compiler for ARM 8.20.1.14183		1260		ULP Mark

EEMBC CoreMark BENCHMARK for the Arm Cortex-M3 Processor and the LPDSP32 DSP						
Arm Cortex-M3 processor running from RAM		At 48 MHz SYSCLK. Using the IAR 8.10.1 C compiler, certified		159		Core Mark
LPDSP32 running from RAM		At 48 MHz SYSCLK Using the 2020.03 release of the Synopsys LPDSP32 C compiler		174		Core Mark
Arm Cortex-M3 processor and LPDSP32 running from RAM, VBAT = 1.25 V		At 48 MHz SYSCLK		123		Core Mark/ mA
Arm Cortex-M3 processor and LPDSP32 running from RAM, VBAT = 3 V		At 48 MHz SYSCLK		293		Core Mark/ mA
Arm Cortex-M3 processor running CoreMark from RAM, VBAT = 1.25 V		At 48 MHz SYSCLK		29.1		μA/MHz
Arm Cortex-M3 processor running CoreMark from RAM, VBAT = 3 V		At 48 MHz SYSCLK		12.3		μA/MHz
Arm Cortex-M3 processor running CoreMark from Flash, VBAT = 1.25 V		At 48 MHz SYSCLK		34.3		μA/MHz
Arm Cortex-M3 processor running CoreMark from Flash, VBAT = 3 V		At 48 MHz SYSCLK		14.6		μA/MHz
LPDSP32 running CoreMark from RAM, VBAT = 1.25 V		At 48 MHz SYSCLK		19.5		μA/MHz
LPDSP32 running CoreMark from RAM, VBAT = 3 V		At 48 MHz SYSCLK		8.2		μA/MHz

INTERNALLY GENERATED VDDC: Digital Block Supply Voltage

Supply voltage: operating range	VDDC		0.92	1.15	1.32 (Note 5)	V
Supply voltage: trimming range	VDDC _{RANGE}		0.75		1.38	V
Supply voltage: trimming step	VDDC _{STEP}			10		mV

INTERNALLY GENERATED VDDM: Memories Supply Voltage

Supply voltage: operating range	VDDM		1.05	1.15	1.32 (Note 6)	V
Supply voltage: trimming range	VDDM _{RANGE}		0.75		1.38	V
Supply voltage: trimming step	VDDM _{STEP}			10		mV

INTERNALLY GENERATED VDDRF: Radio Front end supply voltage

Supply voltage: operating range	VDDRF		1.00	1.10	1.32 (Notes 7 and 8)	V
Supply voltage: trimming range	VDDRF _{RANGE}		0.75		1.38	V
Supply voltage: trimming step	VDDRF _{STEP}			10		mV

INTERNALLY GENERATED VDDPA: Optional Radio Power Amplifier Supply Voltage

Supply voltage: operating range	VDDPA		1.05	1.3	1.68	V
Supply voltage: trimming range	VDDPA _{RANGE}		1.05		1.68	V
Supply voltage: trimming step	VDDPA _{STEP}			10		mV

RSL10

Table 3. ELECTRICAL PERFORMANCE SPECIFICATIONS (continued)

Unless otherwise noted, the specifications mentioned in the table below are valid at 25°C for VBAT = VDDO = 1.25 V in LDO mode, or VBAT = VDDO = 3 V in DC-DC (buck) mode.

Description	Symbol	Conditions	Min	Typ	Max	Units
INTERNALLY GENERATED VDDPA: Optional Radio Power Amplifier Supply Voltage						
Supply voltage: trimming step	DCDC _{STEP}			10		mV
VDDO PAD SUPPLY VOLTAGE: Digital Level High Voltage						
Digital I/O supply	VDDO		1.1	1.25	3.3	V
INDUCTIVE BUCK DC-DC CONVERTER						
VBAT range when the DC-DC converter is active (Note 9)	DCDC IN_RANGE		1.4		3.3	V
VBAT range when the LDO is active	LDO IN_RANGE		1.1		3.3	V
Output voltage: trimming range	DCDC OUT_RANGE		1.1	1.2	1.32	V
Supply voltage: trimming step	DCDC _{STEP}			10		mV
POWER-ON RESET						
POR voltage	VBAT _{POR}		0.4	0.8	1.0	V
RADIO FRONT-END: General Specifications						
RF input impedance	Z _{in}	Single ended		50		Ω
Input reflection coefficient	S ₁₁	All channels			-8	dB
Data rate FSK / MSK / GFSK	R _{FSK}	OQPSK as MSK	62.5	1000	3000	kbps
Data rate 4-FSK					4000	kbps
On-air data rate	bps	GFSK	250		2000	kbps
RADIO FRONT-END: Crystal and Clock Specifications						
Xtal frequency	F _{XTAL}	Fundamental		48		MHz
Equiv. series Res.	ESR _{XTAL}	RSL10 has internal load capacitors, additional external capacitors are not required	20		80	Ω
Differential equivalent load capacitance	CL _{XTAL}	Internal load capacitors (NO EXTERNAL LOAD CAPACITORS REQUIRED)	6	8	10	pF
Settling time				0.5	1.5	ms
RADIO FRONT-END: Synthesizer Specifications						
Frequency range	F _{RF}	Supported carrier frequencies	2360		2500	MHz
RX frequency step		RX Mode frequency synthesizer resolution			100	Hz
TX frequency step		TX Mode frequency synthesizer resolution			600	Hz
PLL Settling time, RX	t _{PLL_RX}	RX Mode		15	25	μs
PLL Settling time, TX	t _{PLL_TX}	TX mode, BLE modulation		5	10	μs
RADIO FRONT-END: Receive Mode Specifications						
Current consumption at 1 Mbps, V _{BAT} = 1.25 V	IBAT _{RFRX}	VDDRF = 1.1 V, 100% duty cycle		5.6		mA
Current consumption at 2 Mbps, V _{BAT} = 1.25 V	IBAT _{RFRX}	VDDRF = 1.1 V, 100% duty cycle		6.2		mA
Current consumption at 1 Mbps, V _{BAT} = 3 V, DC-DC	IBAT _{RFRX}	VDDRF = 1.1 V, 100% duty cycle		3.0		mA
Current consumption at 2 Mbps, V _{BAT} = 3 V, DC-DC	IBAT _{RFRX}	VDDRF = 1.1 V, 100% duty cycle		3.4		mA
RX Sensitivity, 0.25 Mbps		0.1% BER (Notes 10, 11)		-97		dBm
RX Sensitivity, 0.5 Mbps		0.1% BER (Notes 10, 11)		-96		dBm

RSL10

Table 3. ELECTRICAL PERFORMANCE SPECIFICATIONS (continued)

Unless otherwise noted, the specifications mentioned in the table below are valid at 25°C for VBAT = VDDO = 1.25 V in LDO mode, or VBAT = VDDO = 3 V in DC-DC (buck) mode.

Description	Symbol	Conditions	Min	Typ	Max	Units
RADIO FRONT-END: Receive Mode Specifications						
RX Sensitivity, 1 Mbps, BLE		0.1% BER (Notes 10, 11) Single-ended on chip antenna match to 50 Ω		-94		dBm
RX Sensitivity, 2 Mbps, BLE		0.1% BER (Notes 10, 11)		-92		dBm
RSSI effective range		Without AGC		60		dB
RSSI step size				2.4		dB
RX AGC range				48		dB
RX AGC step size		Programmable		6		dB
Max usable signal level		0.1% BER	0	5		dBm

RADIO FRONT-END: Transmit Mode Specifications

Tx peak power consumption at VBAT = 1.25 V (Note 12)	IBAT _{RFTX}	Tx power 0 dBm, VDDRF = 1.07 V, VDDPA: off, LDO mode		8.9		mA
		Tx power 3 dBm, VDDRF = 1.1 V, VDDPA = 1.26 V, LDO mode		17.4		mA
		Tx power 6 dBm, VDDRF = 1.1 V, VDDPA = 1.60 V, LDO mode		25		mA
Tx peak power consumption at VBAT = 3 V (Note 12)	IBAT _{RFTX}	Tx power 0 dBm, VDDRF = 1.07 V, VDDPA: off, DC-DC mode		4.6		mA
		Tx power 3 dBm, VDDRF = 1.1 V, VDDPA = 1.26 V, DC-DC mode		8.6		mA
		Tx power 6 dBm, VDDRF = 1.1 V, VDDPA = 1.60 V, DC-DC mode		12		mA
Transmit power range		BLE or 802.15.4 OQPSK	-17		+6	dBm
Transmit power step size		Full band.		1		dB
Transmit power accuracy		Tx power 3 dBm. Full band. Relative to the typical value.	-1.5		+1	dB
		Tx power 0 dBm. Full band. Relative to the typical value.	-1.5		1.5	dB
Power in 2 nd harmonic		0 dBm mode. 50 Ω for "Typ" value. (Note 13)		-31	-18	dBm
Power in 3 rd harmonic		0 dBm mode. 50 Ω for "Typ" value. (Note 13)		-40	-31	dBm
Power in 4 th harmonic		0 dBm mode. 50 Ω for "Typ" value. (Note 13)		-49	-42	dBm

ADC

Resolution	ADC _{RES}		8	12	14	bits
Input voltage range	ADC _{RANGE}		0		2	V
INL	ADC _{INL}		-2		+2	mV
DNL	ADC _{DNL}		-1		+1	mV
Channel sampling frequency	ADC _{CH_SF}	For the 8 channels sequentially, SLOWCLK = 1 MHz	0.0195		6.25	kHz

32 kHz ON-CHIP RC OSCILLATOR

Untrimmed Frequency	Freq _{UNTR}		20	32	50	kHz
Trimming steps	Steps			1.5		%

3 MHz ON-CHIP RC OSCILLATOR

Untrimmed Frequency	Freq _{UNTR}		2	3	5	MHz
Trimming steps	Steps			1.5		%
Hi Speed mode	Fhi			10		MHz

RSL10

Table 3. ELECTRICAL PERFORMANCE SPECIFICATIONS (continued)

Unless otherwise noted, the specifications mentioned in the table below are valid at 25°C for VBAT = VDDO = 1.25 V in LDO mode, or VBAT = VDDO = 3 V in DC-DC (buck) mode.

Description	Symbol	Conditions	Min	Typ	Max	Units
32 kHz ON-CHIP CRYSTAL OSCILLATOR (Note 14)						
Output Frequency	Freq _{32k}	Depends on xtal parameters		32768		Hz
Startup time				1	3	s
Internal load trimming range		Steps of 0.4 pF	0		25.2	pF
Load Capacitance		No external load capacitors required. Maximum external parasitic capacity allowed (package, routing, etc.)			3.5	pF
ESR					100	kΩ
Duty Cycle			40	50	60	%

DC CHARACTERISTICS OF THE DIGITAL PADS – With VDDO = 2.97 V – 3.3 V, nominal: 3.0 V Logic

Voltage level for high input	V _{IH}		2		VDDO+0.3	V
Voltage level for low input	V _{IL}		VSSD-0.3		0.8	V

DC CHARACTERISTICS OF THE DIGITAL PADS – With VDDO = 1.1 V – 1.32 V, nominal: 1.2 V Logic

Voltage level for high Input	V _{IH}		0.65* VDDO		VDDO+0.3	V
Voltage level for low input	V _{IL}		VSSD-0.3		0.35* VDDO	V

DIO DRIVE STRENGTH

DIO drive strength	IDIO		2	12	12	mA
--------------------	------	--	---	----	----	----

FLASH SPECIFICATIONS

Endurance of the 384 kB of flash			100,000			write/erase cycles
Endurance for sections NVR1, NVR2, and NVR3 (6 kB in total)			1000			write/erase cycles
Retention			25			years

Product parametric performance is indicated in the Electrical Characteristics for the listed test conditions, unless otherwise noted. Product performance may not be indicated by the Electrical Characteristics if operated under different conditions.

5. The maximum VDDC voltage cannot exceed the VBAT input voltage or the VCC output from the buck converter.
6. The maximum VDDM voltage cannot exceed the VBAT input voltage or the VCC output from the buck converter.
7. The maximum VDDRF voltage cannot exceed the VBAT input voltage or the VCC output from the buck converter.
8. The VDDRF calibrated targets are:
 - 1.10 V (TX power > 0 dBm, with optimal RX sensitivity)
 - 1.07 V (TX power = 0 dBm)
 - 1.20 V (TX power = 2 dBm)
 The VDDPA calibrated targets are:
 - 1.30 V
 - 1.26 V (TX power = 3 dBm, assumes VDDRF = 1.10 V)
 - 1.60 V (TX power = 6 dBm, assumes VDDRF = 1.10 V)
9. The LDO can be used to regulate down from VBAT and generate VCC. For VBAT values higher than 1.5 V, the LDO is less efficient and it is possible to save power by activating the DC-DC converter to generate VCC.
10. Signal generated by RF tester.
11. 0.5 to 1.0 dB degradation in the RX sensitivity is present on the QFN package vs WLCSP. This is attributed to the presence of the metal slug of the QFN package which is in close proximity to on-chip inductors.
12. All values are based on evaluation board performance at the antenna connector, including the harmonic filter loss.
13. The values shown here are without RF filter. Harmonics need to be filtered with an external filter (See "RF Filter" on Table 6).
14. These specifications have been validated with the Epson Toyocom MC – 306 crystal.

RSL10

Table 4. VDDM TARGET TRIMMING VOLTAGE IN FUNCTION OF VDDO VOLTAGE

VDDM Voltage (V)	DIO_PAD_CFG DRIVE	Maximum VDDO Voltage (V)
1.05	1	2.7
1.05	0	3.2
1.10	0	3.3

NOTE: These are trimming targets at room/ATE temperature 25~30°C.

Table 5. VDDC TARGET TRIMMING VOLTAGE IN FUNCTION OF SYSCLK FREQUENCY

VDDC Voltage (V)	Maximum SYSCLK Frequency (MHz)	Restriction
0.92	≤ 24	The ADC will be functional in low frequency mode and between 0 and 85°C only.
1.00	≤ 24	Fully functional
1.05	48	Fully functional

NOTE: These are trimming targets at room/ATE temperature 25~30°C.

Table 6. RECOMMENDED EXTERNAL COMPONENTS:

Components	Function	Recommended typical value	Tolerance
Cap (VBAT-VSSA)	VBAT decoupling	4.7 μF // 100 pF (Note 15)	±20%
Cap (VDDO-VSSD)	VDDO decoupling	1 μF	±20%
Cap (VDDRF-VSSRF)	VDDRF decoupling	2.2 μF	±20%
Cap (VCC-VSSA)	VCC decoupling	Low ESR 2.2 μF (Note 16) or 4.7 μF	±20%
Cap (VDDA-VSSA)	VDDA decoupling	1 μF	±20%
Cap (CAP0-CAP1)	Pump capacitor for the charge pump	1 μF	±20%
Inductor (DC-DC)	DC-DC converter inductance	Low ESR 2.2 μH (See Table 7 below)	±20%
Xtal_32 kHz	Xtal for 32 kHz oscillator	- MC - 306, Epson - CM8V-T1A, Micro Crystal Switzerland WMRAG32K76CS1C00R0, Murata	
Xtal_48 MHz	Xtal for 48 MHz oscillator	8Q-48.000MEEV-T, TXC Corporation, Taiwan XRCTD48M000NXQ2ER0, Murata	
RF filter (Note 17)	External harmonic filter	1.5 pF / 3 nH / 1.5 pF / 1.8 nH	±20%

NOTE: All capacitors used must have good RF performance.

15. The recommended decoupling capacitance uses 2 capacitors with the values specified.

16. Example: AMK105BJ225_P, Taiyo Yuden.

17. For improved harmonic performance in environments where RSL10 is operating in close proximity to smartphones or base stations, FBAR filters such as the Broadcom ACPF-7924 can be applied instead of the suggested discrete harmonic filter.

Table 7. RECOMMENDED DC-DC CONVERTER INDUCTANCE TABLE

Manufacturer	Part Number	Case Size	Comments
Taiyo Yuden	CKP2012N_2R2	0805 SMD with T _{max} = 1.0 mm	A degradation of 1 dB in the RX sensitivity is expected in DC-DC mode (Vbat = 3.3 V) versus LDO mode operation.
Taiyo Yuden	CBMF1608T2R2M	0603 SMD with T _{max} = 1.0 mm	A degradation of <1 dB in RX sensitivity is expected in DC-DC mode (Vbat = 3.3 V) versus LDO mode operation. Also, the current drawn from the battery will be 4-10% higher than when the CKP2012N_2R2 is used depending on operation mode and settings.

NOTE: Values have been measured on the QFN version of the RSL10 development board.

RSL10

PCB Design Guidelines

1. Decoupling capacitors should be placed as close to the related balls as possible.
2. Differential output signals should be routed as symmetrically as possible.
3. Analog input signals should be shielded as well as possible.
4. Pay close attention to the parasitic coupling capacitors.
5. Special care should be made for PCB design in order to obtain good RF performance.
6. Multi-layer PCB should be used with a keep-out area on the inner layers directly below the antenna matching circuitry in order to reduce the stray capacitances that influence RF performance.
7. All the supply voltages should be decoupled as close as possible to their respective pin with high performance RF capacitors. These supplies should be routed separately from each other and if possible on different layers with short lines on the PCB from the chip's pin to the supply source.
8. Digital signals shouldn't be routed close to the crystal or the power supply lines.
9. Proper DC-DC component placement and layout is critical to RX sensitivity performance in DC-DC mode.

RSL10

Table 8. BUMP AND COATING SPECIFICATIONS

Subject	Specification
Bump metallization	Sn 97.7%/Ag 2.3%
Backside coating specification	Lintec Adwill LC2850
Backside coating thickness	25 μm

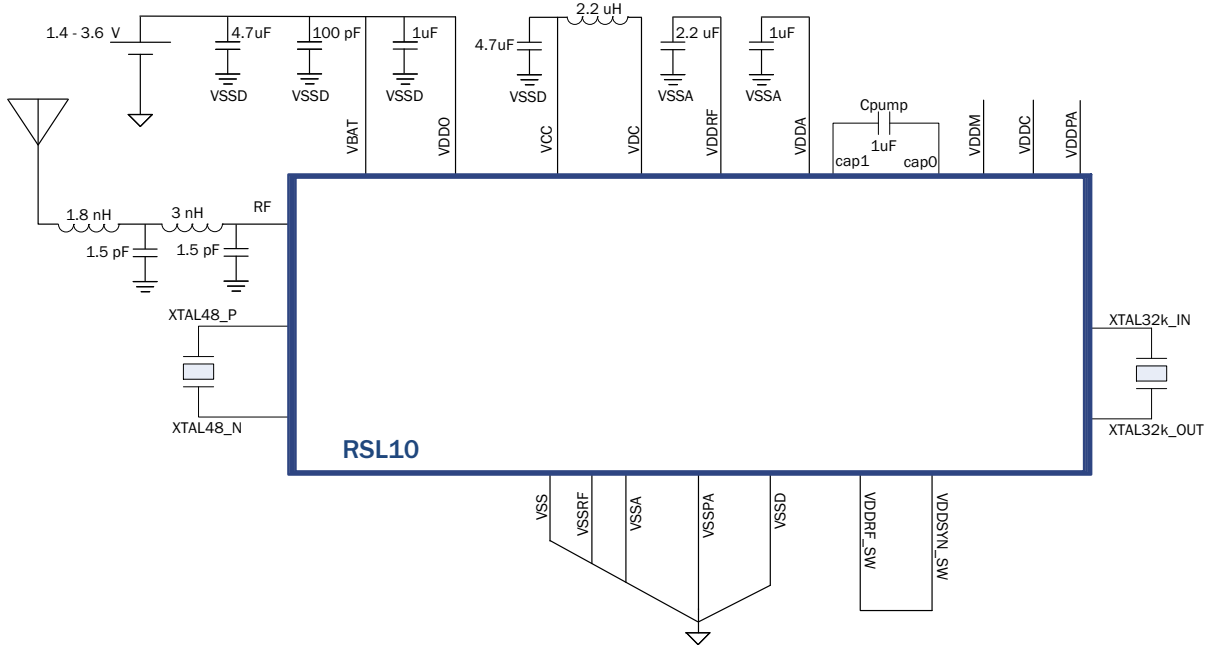
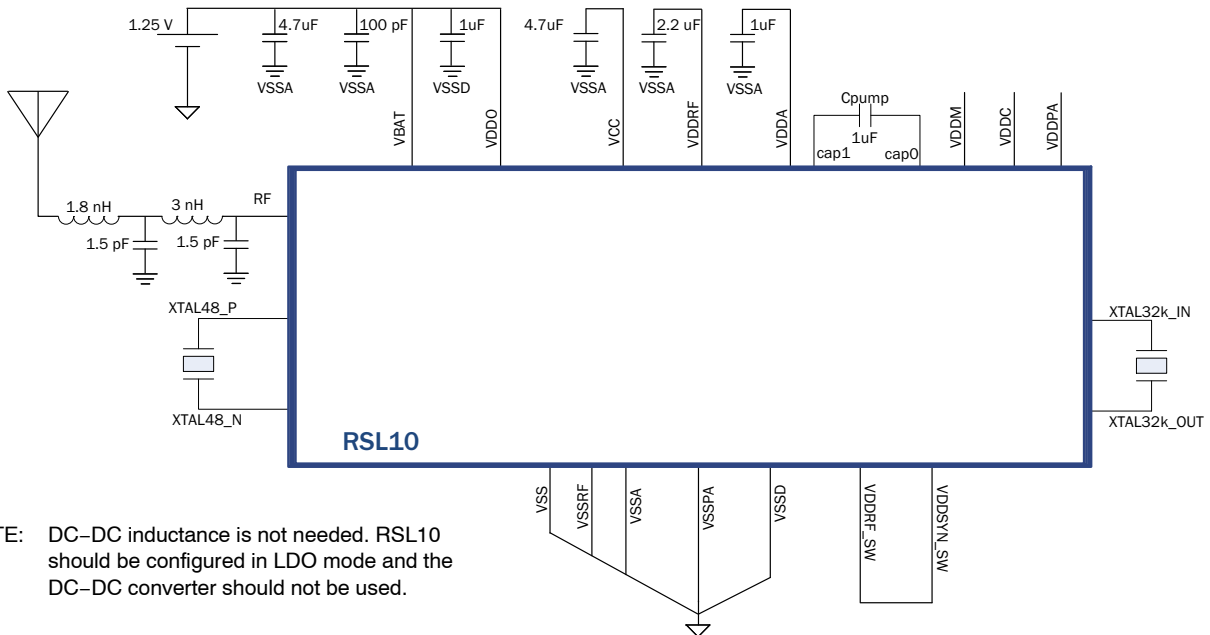

Figure 2. RSL10 Application Diagram in Buck Mode



NOTE: DC-DC inductance is not needed. RSL10 should be configured in LDO mode and the DC-DC converter should not be used.

Figure 3. RSL10 Application Diagram in LDO Mode

RSL10

Table 9. CHIP INTERFACE SPECIFICATIONS

Pad Name	Description	Power Domain	I/O	A/D	Pull	Pad #, WLCSP	Pad #, QFN48
VBAT	Battery input voltage	VBAT	I	P		K5,K7,K10	9
VDC	DC-DC output voltage to external LC filter		O	A		J11	10
VCC	DC-DC filtered output		I	P/A		K11	12
XTAL32_IN	Xtal input pin for 32 kHz xtal		I/O	A		L10	14
XTAL32_OUT	Xtal output pin for 32 kHz xtal		I/O	A		L11	13
VSSA	Analog ground		I/O	P		E10	8
RES	RESERVED		I	D	D	F8	11
VDDA	Charge pump output for analog and flash supplies	VDDA	I/O	P/A		F11	5
VDDRF	LDO's output for radio voltage supply		I/O	P/A		A11	48
CAP0	Pump capacitor connection		O	A		H11	7
CAP1	Pump capacitor connection		O	A		G10	6
AOUT	Analog test pin		O	A		L6	4
VDDRF_SW	Supply pin for the RF	VDDRF_SW		P/A		A9	47
VDDSYN_SW	Supply pin for the radio synthesizer			P/A		B8	45
VSSRF	RF analog ground		I/O	P		B9	46
XTAL48_N	Negative input for the 48 MHz xtal block		I/O	A		A6	43
XTAL48_P	Positive input for the 48 MHz xtal block		I/O	A		A8	44
VDDPA	Radio power amplifier voltage supply	VDDPA	I/O	P/A		C11	2
VSSPA	Radio power amplifier ground		I/O	P		D11	3
RF	RF signal input/output (Antenna)	RF	I/O	A		B11	1
VPP	Flash high voltage access	VPP	I/O	A		J6	17

RSL10

Table 9. CHIP INTERFACE SPECIFICATIONS (continued)

Pad Name	Description	Power Domain	I/O	A/D	Pull	Pad #, WLCSP	Pad #, QFN48
NRESET	Reset pin	VDDO	I	D	U1	L9	16
WAKEUP	Wake-up pin for power modes		I	A		L8	15
VDDC	LDO output for Core logic voltage supply		I/O	P		H6	19
VDDM	LDO output for memories voltage supply		I/O	P		F4	21
VDDO	Digital I/O voltage supply		I	P		B4	36
VSSD	Digital ground pad for I/O		I/O	P		F3, D6, F9	28, 35
VSS (*)	Substrate connection for the RF part		I/O	P		B6	42
EXTCLK	External clock input		I	D	U	F1	31
DIO[0]	Digital input output / ADC 0 / Wakeup 0 / STANDBYCLK input		I/O	A/D	U/D	L4	18
DIO[1]	Digital input output / ADC 1 / Wakeup 1 / STANDBYCLK input		I/O	A/D	U/D	L3	20
DIO[2]	Digital input output / ADC 2 / Wakeup 2 / STANDBYCLK input		I/O	A/D	U/D	L2	23
DIO[3]	Digital input output / ADC 3 / Wakeup 3 / STANDBYCLK input		I/O	A/D	U/D	L1	25
DIO[4]	Digital input output 4		I/O	D	U/D	K2	24
DIO[5]	Digital input output 5		I/O	D	U/D	K1	27
DIO[6]	Digital input output 6		I/O	D	U/D	J1	29
DIO[7]	Digital input output 7		I/O	D	U/D	H1	30
DIO[8]	Digital input output 8		I/O	D	U/D	G2	26
DIO[9]	Digital input output 9		I/O	D	U/D	E2	22
DIO[10]	Digital input output 10		I/O	D	U/D	D1	32
DIO[11]	Digital input output 11		I/O	D	U/D	B2	38
DIO[12]	Digital input output 12		I/O	D	U/D	A1	37
DIO[13]	Digital input output / CM3-JTAG Test Reset		I/O	D	U/D	A2	39
DIO[14]	Digital input output / CM3-JTAG Test Data In		I/O	D	U/D	A3	41
DIO[15]	Digital input output / CM3-JTAG Test Data Out		I/O	D	U/D	A4	40
JTCK	CM3-JTAG Test Clock		I/O	D	U	C1	33
JTMS	CM3-JTAG Test Mode State		I/O	D	U	B1	34

*VSS should be connected to VSSRF at the PCB level.

NOTE: It is recommended that the QFN package metal slug be left open/floating for optimal Rx sensitivity performance.

Legend:

Type: A = analog; D = digital; I = input; O = output; P = power

Pull: U = pull up; D = pull down

Pull up: selectable between 10 kΩ and 250 kΩ. U1 = pull up, 200 kΩ.

Pull down: 250 kΩ

All digital pads have a Schmitt trigger input.

All DIO pads have a programmable I²C low pass filter. All DIOs can be configured to no pull.

RSL10

ARCHITECTURE OVERVIEW

The architecture of the RSL10 chip is shown in Figure 4.

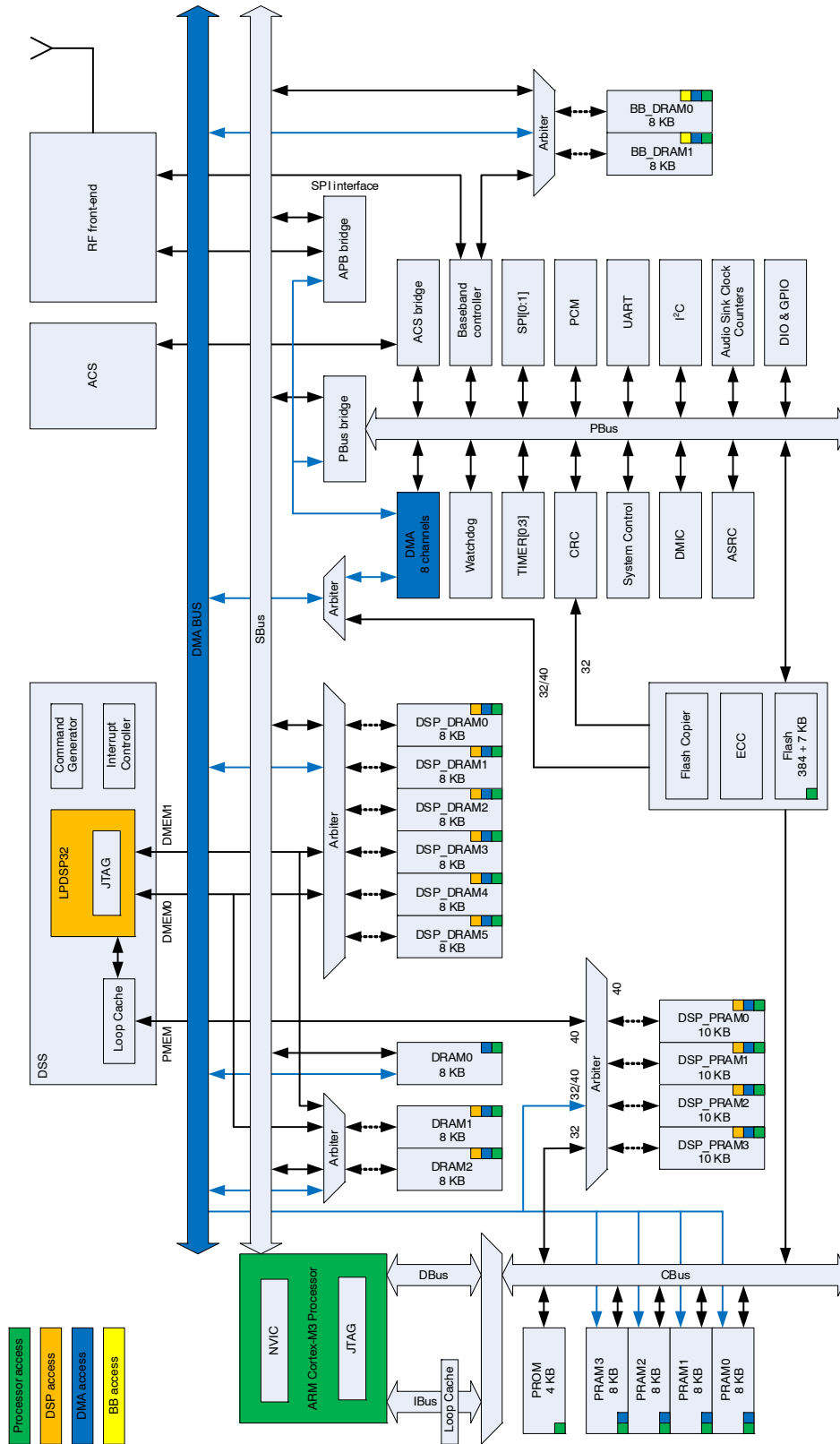

Figure 4. RSL10 Architecture

Power Management Unit

The RSL10 power management unit prevents system brown-outs in case the battery voltage dips below the specified minimum voltage required for reliable operation. It does this by:

1. Monitoring the power supply and safely shutting down the system if needed.
2. Preventing possible damage to RSL10 when the battery is inserted or removed.
3. Allowing operation across wide temperature and voltage ranges at low power consumption.

RSL10 allows the use of either the DC-DC converter for a better efficiency when the battery voltage is higher than 1.4 V or the internal LDO when VBAT is lower than 1.4 V. The output of the DC-DC converter or the LDO regulator is used to supply other voltage regulator blocks of RSL10. These blocks are:

- A programmable voltage regulator to supply the digital cores (VDDC)
- A programmable voltage regulator to supply the memories (VDDM)
- A charge pump supplying the analog blocks and the flash memory (VDDA)
- A programmable voltage regulator to supply the radio front-end (VDDRF)
- A programmable voltage regulator to supply the power amplifier of the radio (VDDPA): This regulator is used only for the +6 dBm output power case or if we want to transmit at +3 dBm output power with a battery level less than 1.4 V. The VDDPA regulator can be disabled if RSL10 doesn't have to transmit at high power, and VDDRF only should be used.

Clock and Clocking Options

RSL10's system clock (SYSCLK) can come from various sources:

- A 48 MHz crystal oscillator, used in normal operation mode
- An internal trimmable RC oscillator that supplies a 3 MHz – 12 MHz clock used at system startup
- A Real Time Clock, used in stand-by mode, generated from one of:
 - ◆ A 32 kHz RC oscillator
 - ◆ A 32 kHz crystal oscillator
 - ◆ An external input on one of DIO0 to DIO3
- A JTAG clock, used in debug mode, coming from the JTCK pad
- An external clock source, coming from the EXTCLK pad

Every clock generated in the system can be disabled when they are not needed. Also, every clock has an associated configurable prescaler to minimize the power dissipated on the clock tree.

A clock detector unit can be used to monitor the system clock and/or the RTC clock in sleep and standby modes. In the event the clock frequency goes below a certain threshold, the RSL10 IC will be reset. The clock detector threshold is nominally 2 kHz. This block and the reset it triggers is enabled by default, but both can be disabled.

Radio Front-End

RSL10 2.4 GHz radio front-end implements the physical layer for the Bluetooth low energy technology standard and other standard, proprietary, and custom protocols. It operates in the worldwide deployable 2.4 GHz ISM band (2.4000 to 2.4835 GHz) and supports:

- Bluetooth 5 certified with LE 2M PHY support
- **onsemi's** custom audio protocol and other custom protocols

The RSL10 Radio Front End includes the necessary hardware to support the following protocols:

- The IEEE 802.15.4 standard, used as the physical layer for many standard and proprietary protocols including ZigBee and Thread
- Proprietary protocols or proprietary audio protocols

The 2.4 GHz radio front-end is based on a low-IF architecture and comprises the following building blocks:

- High performance single-ended RF port
- On-chip matching network with 50 ohm RF input
- High gain, low power LNA (low noise amplifier), and mixer
- PA (Power Amplifier) with +3 dBm output power for Bluetooth and 802.15.4 OQPSK applications, and up to +6 dBm with dedicated PA voltage supply
- ADC converter
- RSSI (Received Signal Strength Indication) with 60 dB nominal range with 2.4 dB steps (not considering AGC)
- Fully integrated ultra-low power frequency synthesis with fast settling time, with direct digital modulation in transmission (pulse shape programmable)
- 48 MHz XTAL reference (finely trimmable)
- Fully-integrated FSK-based modem with programmable pulse shape, data rate, and modulation index
- Digital baseband (DBB) with Link layer functionalities, including automatic packet handling with preamble & sync, CRC, and separate Rx and Tx 128-bytes FIFOs
- Serial and parallel digital interfaces

The 2.4 GHz radio front-end contains a full transceiver with the following features:

- IEEE 802.15.4 chip encoding & decoding
- Manchester encoding
- Data whitening

The 2.4 GHz radio front-end contains also a highly-flexible digital baseband—in terms of modulations, configurability and programmability – in order to support Bluetooth low energy technology, 802.15.4 OQPSK and DSSS, and proprietary protocols. It allows for programmable data rates from 62.5 kbps up to 2 Mbps, FSK with programmable pulse shape and modulation index.

The 2.4 GHz radio front-end also include IEEE 802.15.4 chip encoding & decoding, Manchester encoding and Data whitening. Its packet handling includes:

- Automatic preamble and sync word insertion
- Automatic packet length handler
- Basic address check
- Automatic CRC calculation and verification with a programmable CRC polynomial
- Multi-frame support
- 2x128 byte FIFOs

Baseband Controller and Software Stack

The RSL10 Bluetooth baseband controller is connected to the radio front-end. It configures the physical layer of the RSL10 for use as a Bluetooth low energy technology device. It provides access and support for the Direct-Test Mode (DTM) layer for RF testing, and it implements portions of the link layer and other controller level components from the Bluetooth stack. It is dedicated to low level bitwise operations and data packet processing.

RSL10 is Bluetooth 5 certified and includes LE 2 Mbps support and all optional features from earlier versions of Bluetooth low energy technology.

The RSL10 device also supports custom software stacks for:

- Custom audio protocol to support low-latency audio streaming
- Custom audio protocol to support low-power audio streaming from a remote dongle

Also, the coexistence between Bluetooth and a custom protocol is supported. For example, when streaming audio from a remote dongle, it is possible to also use the phone to control the audio device using the standard Bluetooth low energy technology protocol.

The software stack, including the profiles and the application, handles the protocol functions and is executed on the Arm Cortex-M3 processor. The Bluetooth IP implementation is split among software and hardware as shown in Figure 5.

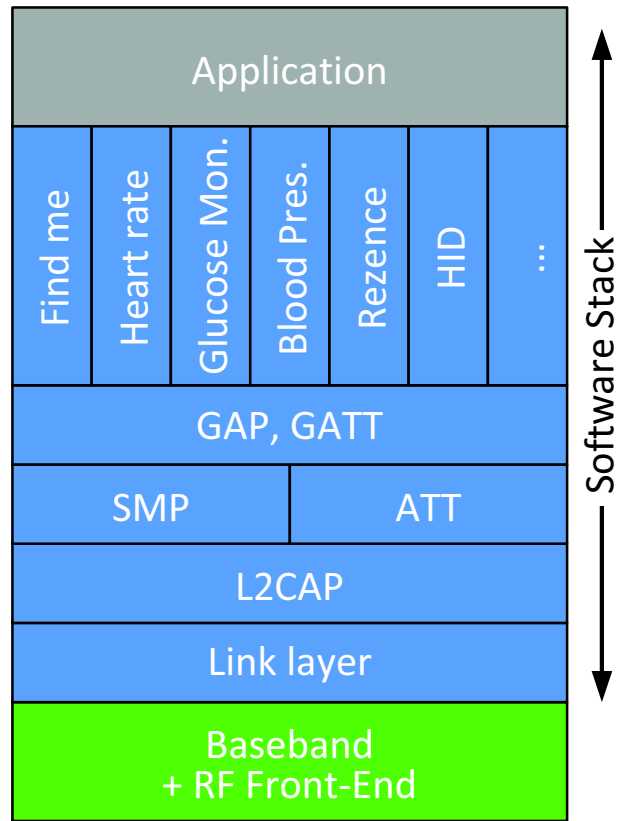

Figure 5. Bluetooth Protocol Implementation

The following is a sample of the Bluetooth low energy profiles supported by RSL10. For more information and a complete list of the profiles offered, please download the RSL10 development tools kit.

- Find Me
- Proximity
- Health Thermometer
- Heart Rate
- Time
- Blood Pressure
- Glucose Monitor
- HID over GATT (HOG)
- Alert Notification
- Phone Alert Status
- Running Speed
- Cycling Speed
- Cycling Power
- Location and Navigation
- Rezenze (custom protocol defined by AirFuel™ Alliance to support wireless battery charging)

Arm Cortex–M3 Processor Subsystem

The Arm Cortex–M3 processor subsystem includes the Arm Cortex–M3 processor, which is the master processor of the RSL10 chip. It also contains the Bluetooth baseband controller, and all interfaces and other peripherals.

Arm Cortex–M3 Processor

The Arm Cortex–M3 processor is a state-of-the-art 32-bit core with embedded multiplier and ALU for handling typical control functions. Software development is done in C.

It features a low gate count, low interrupt latency, and low-cost debug functionality. It is primarily intended for deeply embedded applications that require low power consumption with fast interrupt response. The processor implements the Arm architecture v7–M. For power management, the processor can be placed under firmware control, into a Standby mode, in which the processor clock is disabled. The Nested Vectored Interrupt Controller (NVIC) will continue to run to enable exiting Standby mode on an interrupt.

LPDSP32

LPDSP32 is a C-programmable, 32-bit DSP developed by **onsemi**. LPDSP32 is a high efficiency, dual Harvard DSP that supports both single (32-bit) and double precision (64-bit) arithmetic.

LPDSP32's dual MAC unit, load store architecture is specifically optimized to support audio processing tasks. The advanced architecture also provides:

- Two 72-bit ALUs capable of doing single and double precision arithmetic and logical operations
- Two 32-bit integer/fractional multipliers
- Four 64-bit accumulators with 8-bit overflow (extension bits)

LPDSP32 can typically support the audio codecs needed to deploy audio device communication use cases. This includes (but is not limited to) codecs to support:

- A 16 kHz sample rate, producing a signal with a 7 kHz bandwidth (E.g.; G.722 and mSBC codec)
- A 24 kHz sample rate, producing a signal with an 11 kHz bandwidth (E.g.: G.722, CELT codec from the OPUS standard)

Communications to the Arm Cortex–M3 processor are completed via interrupts and shared memories. Software development is done in C, and the development tools are provided upon request from Synopsys.

Interfaces

RSL10 includes:

- Two independent SPI interfaces that can be configured in master and slave mode
- A fully configurable PCM interface
- A standard general purpose I²C interface
- A standard general purpose UART interface

- Two PWM (Pulse Width Modulation) drivers that can generate a single bit output signal at a given frequency
- A two-channel digital microphone (DMIC) input
- An output driver (OD) to allow direct connection to high impedance speakers
- SWJ–DP interface for the Arm Cortex–M3 processor
- JTAG interface for the Arm Cortex–M3 processor, internal Flash memory, and the LPDSP32

RSL10 includes 16 DIO pads (Digital Input/Output) that all can be assigned to any of the interfaces above, or used as general purpose DIOs.

Peripherals

RSL10 includes:

- Four general purpose timers
- A DMA (Direct Memory Access) controller to transfer data between peripherals and memories without any core intervention
- A flash copier to initialize SRAM memories and that can be used with the CRC blocks to validate flash memory contents
- An Analog to Digital converter (ADC), accessed by the Arm Cortex–M3 processor. The ADC can read 4 external values (DIO[0]–DIO[3]), AOUT, VDDC, VBAT/2 and the ADC offset value.
- Two standard Cyclic Redundancy Code (CRC) blocks to ensure data integrity of the user application code and data
- An Asynchronous Sample Rate Converter (ASRC) and Audio Sink Clock Counters blocks to provide a means of synchronizing the audio sample rate between the radio link and the host device
- A Watchdog timer to detect and recover from RSL10 malfunctions.
- Four autonomous 32-bit Activity Counters. These counters help analyze how long the system has been running and how much the Arm Cortex–M3 processor, LPDSP32, and the flash memory have been used by the application. This is useful information to estimate and optimize the power consumption of the application.
- An IP protection system to ensure that the flash content cannot be copied by a third party. It can be used to prevent any core or memory of the RSL10 from being accessed externally after the RSL10 has booted.
- Program memory loop caches for each processor to reduce the RSL10 power consumption. This reduces the number of flash and RAM memory accesses by caching the program words that are read in these loops.

RSL10 Memory Structure

Table 10 lists the memory structures attached to RSL10, and the size and width of each memory structure.

RSL10

Table 10. RSL10 MEMORY STRUCTURES

Memory Type	Data Width	Memory Size	Accessed by
Program memory (ROM)	32	4 kB	Arm Cortex-M3 processor
Program memory (RAM)	32	4 instances of 8 kB	Arm Cortex-M3 processor
Program memory (RAM)	40	4 instances of 10 kB	LPDSP32 / Arm Cortex-M3 processor
Data memory (RAM)	32	1 instances of 8 kB	Arm Cortex-M3 processor
Data memory (RAM)	32	2 instances of 8 kB	Arm Cortex-M3 processor / LPDSP32
Data memory (RAM)	32	6 instances of 8 kB	LPDSP32 / Arm Cortex-M3 processor
Data memory (RAM)	32	2 instances of 8 kB	Baseband / Arm Cortex-M3 processor
Flash	32	384 kB	Arm Cortex-M3 processor / Flash copier

Chip Identification

System identification is used to identify different system components. For the RSL10 chip, the key identifier components and values are as follows:

- Chip Family: 0x09
- Chip Version: 0x01
- Chip Major Revision: 0x01

Electrostatic Discharge (ESD) Sensitive Device

CAUTION: ESD sensitive device. Permanent damage may occur on devices subjected to high-energy electrostatic discharges. Proper ESD precautions in handling, packaging and testing are recommended to avoid performance degradation or loss of functionality.

Solder Information

The RSL10 QFN package is constructed with all RoHS compliant material and should be reflowed accordingly.

This device is Moisture Sensitive Class MSL3 and must be stored and handled accordingly. Re-flow according to IPC/JEDEC standard J-STD-020C, Joint Industry Standard: Re-flow Sensitivity Classification for

Nonhermetic Solid State Surface Mount Devices. Hand soldering is not recommended for this part.

For more information, see SOLDERRM/D available from <http://onsemi.com>.

Development Tools

RSL10 is supported by a full suite of comprehensive tools including:

- An easy-to-use development board
- Software Development Kit (SDK) including an Oxygen Eclipse-based development environment, Bluetooth protocol stacks, sample code, libraries, and documentation

Export Control Classification Number (ECCN)

The ECCN designation for RSL10 is 5A991.

Company or Product Inquiries

For more information about **onsemi** products or services visit our Web site at <http://onsemi.com>.

For sales or technical support, contact your local representative or authorized distributor.

MECHANICAL CASE OUTLINE

PACKAGE DIMENSIONS

ON Semiconductor®



1 48
SCALE 2:1

QFN48 6x6, 0.4P
CASE 485BA
ISSUE A

DATE 16 FEB 2010



NOTES:

1. DIMENSIONING AND TOLERANCING PER ASME Y14.5M, 1994.
2. CONTROLLING DIMENSIONS: MILLIMETERS.
3. DIMENSION b APPLIES TO PLATED TERMINAL AND IS MEASURED BETWEEN 0.15 AND 0.30mm FROM TERMINAL TIP.
4. COPLANARITY APPLIES TO THE EXPOSED PAD AS WELL AS THE TERMINALS.

DIM	MILLIMETERS	
	MIN	MAX
A	0.80	1.00
A1	0.00	0.05
A3	0.20	REF
b	0.15	0.25
D	6.00	BSC
D2	4.40	4.60
E	6.00	BSC
E2	4.40	4.60
e	0.40	BSC
K	0.20	MIN
L	0.30	0.50
L1	0.00	0.15

GENERIC MARKING DIAGRAM*

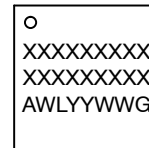

- XXX = Specific Device Code
- A = Assembly Location
- WL = Wafer Lot
- YY = Year
- WW = Work Week
- G = Pb-Free Package

*This information is generic. Please refer to device data sheet for actual part marking. Pb-Free indicator, "G" or microdot "•", may or may not be present. Some products may not follow the Generic Marking.

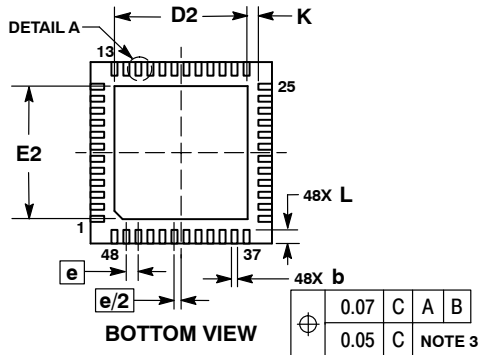

*For additional information on our Pb-Free strategy and soldering details, please download the ON Semiconductor Soldering and Mounting Techniques Reference Manual, SOLDERRM/D.

DOCUMENT NUMBER:	98AON39236E	Electronic versions are uncontrolled except when accessed directly from the Document Repository. Printed versions are uncontrolled except when stamped "CONTROLLED COPY" in red.
DESCRIPTION:	QFN48, 6x6, 0.4MM PITCH	PAGE 1 OF 1

ON Semiconductor and ON are trademarks of Semiconductor Components Industries, LLC dba ON Semiconductor or its subsidiaries in the United States and/or other countries. ON Semiconductor reserves the right to make changes without further notice to any products herein. ON Semiconductor makes no warranty, representation or guarantee regarding the suitability of its products for any particular purpose, nor does ON Semiconductor assume any liability arising out of the application or use of any product or circuit, and specifically disclaims any and all liability, including without limitation special, consequential or incidental damages. ON Semiconductor does not convey any license under its patent rights nor the rights of others.

MECHANICAL CASE OUTLINE

PACKAGE DIMENSIONS

ON Semiconductor®

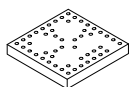

WLCSP51, 2.364x2.325
CASE 567MT
ISSUE A

DATE 13 DEC 2016

SCALE 4:1

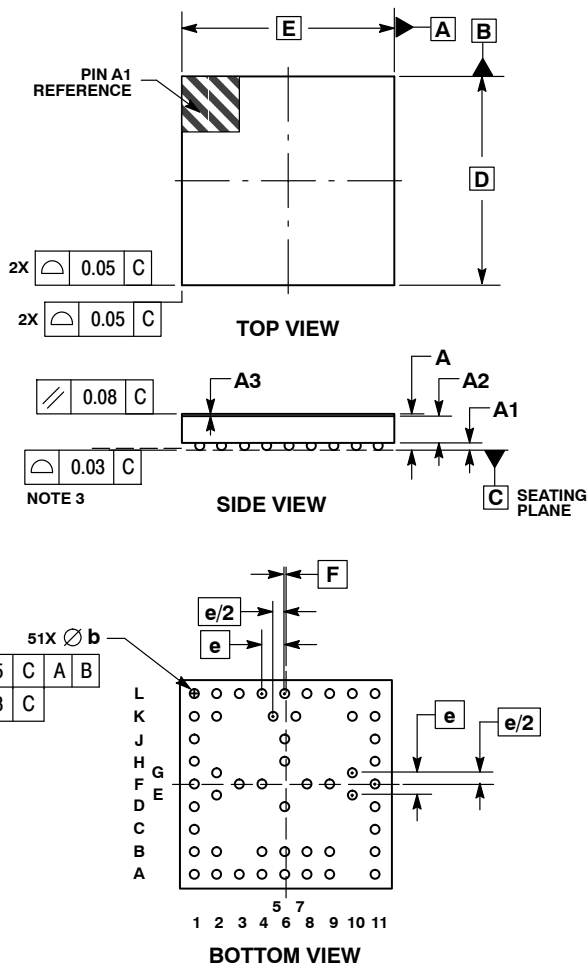

- NOTES:
- DIMENSIONING AND TOLERANCING PER ASME Y14.5M, 1994.
 - CONTROLLING DIMENSION: MILLIMETERS.
 - COPLANARITY APPLIES TO SPHERICAL CROWNS OF SOLDER BALLS.
 - PACKAGE CENTER AND FOOTPRINT CENTER ARE NOT COINCIDENT. REFER TO DIMENSION F FOR OFFSETS.

DIM	MILLIMETERS		
	MIN	NOM	MAX
A	0.319	0.350	0.381
A1	0.060	0.075	0.090
A2	0.237	0.250	0.263
A3	0.022	0.025	0.028
b	0.09	0.10	0.12
D	2.325 BSC		
E	2.364 BSC		
e	0.252 BSC		
F	0.0198 BSC		

GENERIC MARKING DIAGRAM*

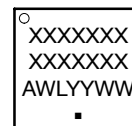

- XXXXXX = Specific Device Code
 A = Assembly Location
 WL = Wafer Lot
 YY = Year
 WW = Work Week
 ■ = Pb-Free Package

*This information is generic. Please refer to device data sheet for actual part marking. Pb-Free indicator, "G" or microdot "■", may or may not be present.

RECOMMENDED SOLDERING FOOTPRINT*

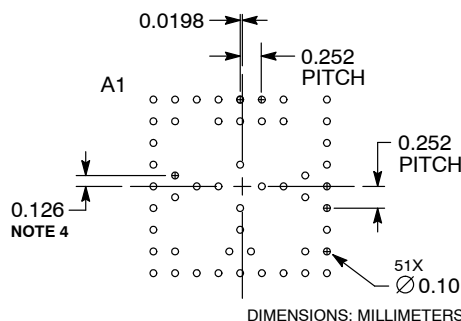

*For additional information on our Pb-Free strategy and soldering details, please download the ON Semiconductor Soldering and Mounting Techniques Reference Manual, SOLDERRM/D.

DOCUMENT NUMBER:	98AON05534G	Electronic versions are uncontrolled except when accessed directly from the Document Repository. Printed versions are uncontrolled except when stamped "CONTROLLED COPY" in red.
DESCRIPTION:	WLCSP51, 2.364X2.325	PAGE 1 OF 1

ON Semiconductor and are trademarks of Semiconductor Components Industries, LLC dba ON Semiconductor or its subsidiaries in the United States and/or other countries. ON Semiconductor reserves the right to make changes without further notice to any products herein. ON Semiconductor makes no warranty, representation or guarantee regarding the suitability of its products for any particular purpose, nor does ON Semiconductor assume any liability arising out of the application or use of any product or circuit, and specifically disclaims any and all liability, including without limitation special, consequential or incidental damages. ON Semiconductor does not convey any license under its patent rights nor the rights of others.

onsemi, **Onsemi**, and other names, marks, and brands are registered and/or common law trademarks of Semiconductor Components Industries, LLC dba "**onsemi**" or its affiliates and/or subsidiaries in the United States and/or other countries. **onsemi** owns the rights to a number of patents, trademarks, copyrights, trade secrets, and other intellectual property. A listing of **onsemi**'s product/patent coverage may be accessed at www.onsemi.com/site/pdf/Patent-Marking.pdf. **onsemi** reserves the right to make changes at any time to any products or information herein, without notice. The information herein is provided "as-is" and **onsemi** makes no warranty, representation or guarantee regarding the accuracy of the information, product features, availability, functionality, or suitability of its products for any particular purpose, nor does **onsemi** assume any liability arising out of the application or use of any product or circuit, and specifically disclaims any and all liability, including without limitation special, consequential or incidental damages. Buyer is responsible for its products and applications using **onsemi** products, including compliance with all laws, regulations and safety requirements or standards, regardless of any support or applications information provided by **onsemi**. "Typical" parameters which may be provided in **onsemi** data sheets and/or specifications can and do vary in different applications and actual performance may vary over time. All operating parameters, including "Typicals" must be validated for each customer application by customer's technical experts. **onsemi** does not convey any license under any of its intellectual property rights nor the rights of others. **onsemi** products are not designed, intended, or authorized for use as a critical component in life support systems or any FDA Class 3 medical devices or medical devices with a same or similar classification in a foreign jurisdiction or any devices intended for implantation in the human body. Should Buyer purchase or use **onsemi** products for any such unintended or unauthorized application, Buyer shall indemnify and hold **onsemi** and its officers, employees, subsidiaries, affiliates, and distributors harmless against all claims, costs, damages, and expenses, and reasonable attorney fees arising out of, directly or indirectly, any claim of personal injury or death associated with such unintended or unauthorized use, even if such claim alleges that **onsemi** was negligent regarding the design or manufacture of the part. **onsemi** is an Equal Opportunity/Affirmative Action Employer. This literature is subject to all applicable copyright laws and is not for resale in any manner.

PUBLICATION ORDERING INFORMATION

LITERATURE FULFILLMENT:

Email Requests to: orderlit@onsemi.com

onsemi Website: www.onsemi.com

TECHNICAL SUPPORT

North American Technical Support:

Voice Mail: 1 800-282-9855 Toll Free USA/Canada

Phone: 011 421 33 790 2910

Europe, Middle East and Africa Technical Support:

Phone: 00421 33 790 2910

For additional information, please contact your local Sales Representative

X-ON Electronics

Largest Supplier of Electrical and Electronic Components

Click to view similar products for [Bluetooth Development Tools - 802.15.1 category](#):

Click to view products by [ON Semiconductor manufacturer](#):

Other Similar products are found below :

[DA14580PRODTLKT](#) [1628](#) [SP14808ST](#) [MBH7BLZ02-EF-KIT](#) [CYBLE-014008-PROG](#) [FWM7BLZ20-EB-KIT](#) [SP14801-DUT](#)
[ATSAMB11ZR-XPRO](#) [SKY66111-21EK1](#) [SECO-RSL10-TAG-GEVB](#) [ENW89857AXKF](#) [3026](#) [MIKROE-2471](#) [MOD-NRF8001](#) [BLE-IOT-](#)
[GEVB](#) [450-0184](#) [EKSHCNZXZ](#) [EVAL_PAN1026](#) [EVAL_PAN1720](#) [EVAL_PAN1740](#) [2267](#) [2479](#) [2487](#) [2633](#) [STEVAL-IDB005V1D](#)
[STEVAL-IDB001V1](#) [MIKROE-2545](#) [SIPKITSLF001](#) [2995](#) [STEVAL-IDB007V1M](#) [2829](#) [DFR0267](#) [DFR0296](#) [DFR0492](#) [TEL0073](#) [BM-70-](#)
[CDB](#) [WSM-BL241-ADA-008DK](#) [STEVAL-BTDP1](#) [ACD52832](#) [TEL0095](#) [ISP1507-AX-TB](#) [RN-4871-PICTAIL](#) [DA14695-00HQDEVKT-P](#)
[DA14695-00HQDEVKT-U](#) [EVK-NINA-B112](#) [EBSHJNZXZ](#) [EKSGJNZWY](#) [EKSHJNZXZ](#) [BMD-200-EVAL-S](#) [ACN BREAKOUT BOARD](#)