

CAT130xx

Voltage Supervisor with Microwire Serial CMOS EEPROM

Description

The CAT130xx (see table below) are memory and supervisory solutions for microcontroller based systems. A CMOS serial EEPROM memory and a system power supervisor with brown-out protection are integrated together. Memory interface is via Microwire serial protocol.

The CAT130xx provides a precision V_{CC} sense circuit with two reset output options: CMOS active low output or CMOS active high. The RESET output is active whenever V_{CC} is below the reset threshold or falls below the reset threshold voltage.

The power supply monitor and reset circuit protect system controllers during power up/down and against brownout conditions. Seven reset threshold voltages support 5 V, 3.3 V, 3 V and 2.5 V systems. If power supply voltages are out of tolerance reset signals become active, preventing the system microcontroller, ASIC or peripherals from operating. Reset signals become inactive typically 240 ms after the supply voltage exceeds the reset threshold level.

Features

- Precision Power Supply Voltage Monitor
 - ◆ 5 V, 3.3 V, 3 V and 2.5 V Systems
 - ◆ 7 Threshold Voltage Options
- Active High or Low Reset
 - ◆ Valid Reset Guaranteed at $V_{CC} = 1$ V
- High Speed Operation
- Selectable x8 or x16 Memory Organization
- Low Power CMOS Technology
- 1,000,000 Program/Erase Cycles
- 100 Year Data Retention
- Industrial Temperature Range
- RoHS-Compliant 8-Pin SOIC Package
- These Devices are Pb-Free, Halogen Free/BFR Free and are RoHS Compliant

THRESHOLD SUFFIX SELECTOR

Nominal Threshold Voltage	Threshold Suffix Designation
4.63 V	L
4.38 V	M
4.00 V	J
3.08 V	T
2.93 V	S
2.63 V	R
2.32 V	Z



ON Semiconductor®

<http://onsemi.com>

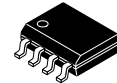

SOIC-8
CASE 751BD

PIN CONFIGURATION

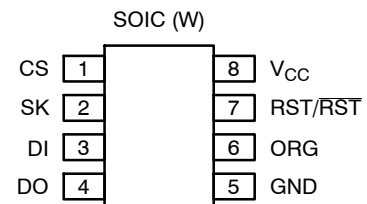

PIN FUNCTION

Pin Name	Function
CS	Chip Select
SK	Clock Input
DI	Serial Data Input
DO	Serial Data Output
GND	Ground
ORG	Memory Organization
RST/RST	Reset Output
V_{CC}	Power Supply

NOTE:

When the ORG pin is connected to V_{CC} , the x16 organization is selected. When it is connected to ground, the x8 pin is selected. If the ORG pin is left unconnected, then an internal pullup device will select the x16 organization.

MEMORY SIZE SELECTOR

Product	Memory Density
13001	1-Kbit
13004	4-Kbit
13008	8-Kbit
13016	16-Kbit

ORDERING INFORMATION

For Ordering Information details, see page 10.

CAT130xx

BLOCK DIAGRAM

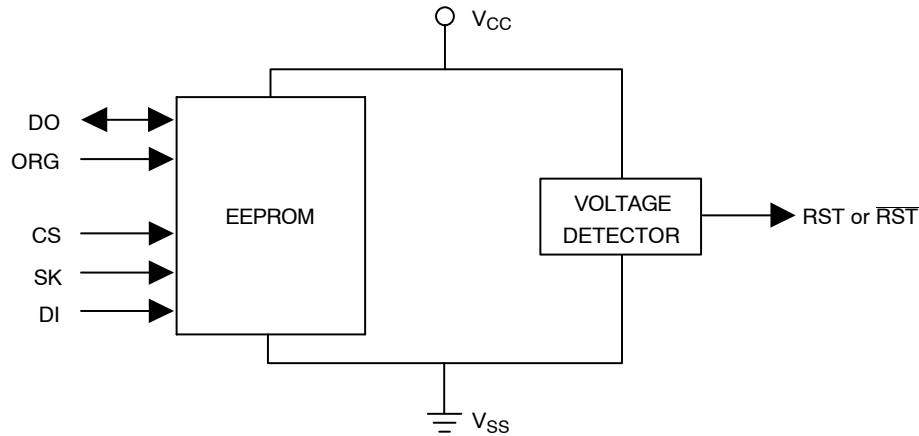

SPECIFICATIONS

Table 1. ABSOLUTE MAXIMUM RATINGS

Parameters	Ratings	Units
Storage Temperature	-65 to +150	°C
Voltage on Any Pin with Respect to Ground (Note 1)	-0.5 to +6.5	V

Stresses exceeding Maximum Ratings may damage the device. Maximum Ratings are stress ratings only. Functional operation above the Recommended Operating Conditions is not implied. Extended exposure to stresses above the Recommended Operating Conditions may affect device reliability.

1. The DC input voltage on any pin should not be lower than -0.5 V or higher than $V_{CC} + 0.5$ V. During transitions, the voltage on any pin may undershoot to no less than -1.5 V or overshoot to no more than $V_{CC} + 1.5$ V, for periods of less than 20 ns.

Table 2. RELIABILITY CHARACTERISTICS (Note 2)

Symbol	Parameter	Min	Units
NEND (Note 3)	Endurance	1,000,000	Program/ Erase Cycles
TDR	Data Retention	100	Years

2. These parameters are tested initially and after a design or process change that affects the parameter according to appropriate AEC-Q100 and JEDEC test methods.
3. Block Mode, $V_{CC} = 5$ V, 25°C

Table 3. D.C. OPERATING CHARACTERISTICS

$V_{CC} = +2.5$ V to +5.5 V, unless otherwise specified.

Symbol	Parameter	Test Conditions	Min	Typ	Max	Units
I_{CC}	Supply Current	Read or Write at 1 MHz			3	mA
I_{SB}	Standby Current	$V_{CC} < 5.5$ V; All I/O Pins at V_{SS} or V_{CC}		12	25	μ A
		$V_{CC} < 3.6$ V; All I/O Pins at V_{SS} or V_{CC}		10	20	
I_L	I/O Pin Leakage	Pin at GND or V_{CC}			2	μ A
V_{IL}	Input Low Voltage		-0.5		0.8	V
V_{IH}	Input High Voltage		2.0		$V_{CC} + 0.5$	V
V_{OL}	Output Low Voltage	$V_{CC} \geq 2.5$ V, $I_{OL} = 2.1$ mA			0.4	V
V_{OH}	Output High Voltage	$V_{CC} \geq 4.5$ V, $I_{OL} = -0.4$ mA	2.4			V

CAT130xx

Table 4. A.C. CHARACTERISTICS (MEMORY) (Note 1)

$V_{CC} = +2.5\text{ V to }5.5\text{ V}$, $T_A = -40^\circ\text{C to }85^\circ\text{C}$, unless otherwise specified.

Symbol	Parameter	Min	Max	Units
f_{SK}	Clock Frequency	DC	2000	kHz
t_{CSS}	CS Setup Time	50		ns
t_{CSH}	CS Hold Time	0		ns
t_{CSMIN}	Minimum CS Low Time	0.25		μs
t_{SKHI}	Minimum SK High Time	0.25		μs
t_{SKLOW}	Minimum SK Low Time	0.25		μs
t_{DIS}	DI Setup Time	100		ns
t_{DIH}	DI Hold Time	100		ns
t_{PD1}	Output Delay to 1		0.25	μs
t_{PD0}	Output Delay to 0		0.25	μs
t_{HZ} (Note 1)	Output Delay to High-Z		100	ns
t_{SV}	Output Delay to Status Valid		0.25	μs
t_{EW}	Program/Erase Pulse Width		5	ms
t_{PU} (Notes 2 & 3)	Power-up to Ready Mode		1	ms

1. Test conditions according to "A.C. Test Conditions" table.
2. Tested initially and after a design or process change that affects this parameter.
3. t_{PU} is the delay between the time V_{CC} is stable and the device is ready to accept commands.

Table 5. A.C. TEST CONDITIONS

Parameter	Test Conditions
Input Rise and Fall Times	$\leq 50\text{ ns}$
Input Levels	0.4 V to 2.4 V ($4.5\text{ V} < V_{CC} < 5.5\text{ V}$)
Input Levels	0.2 V_{CC} to 0.7 V_{CC} ($2.5\text{ V} < V_{CC} < 4.5\text{ V}$)
Timing Reference Levels	0.8 V, 2.0 V ($4.5\text{ V} < V_{CC} < 5.5\text{ V}$)
Timing Reference Levels	0.5 V_{CC} ($2.5\text{ V} < V_{CC} < 4.5\text{ V}$)
Output Load	Current Source: $I_{OL\text{ max}}$ / $I_{OH\text{ max}}$; $C_L = 100\text{ pF}$

CAT130xx

Table 6. ELECTRICAL CHARACTERISTICS (SUPERVISORY FUNCTION)

V_{CC} = Full range, T_A = -40°C to $+85^{\circ}\text{C}$ unless otherwise noted. Typical values at T_A = $+25^{\circ}\text{C}$ and V_{CC} = 5 V for L/M/J versions, V_{CC} = 3.3 V for T/S versions, V_{CC} = 3 V for R version and V_{CC} = 2.5 V for Z version.

Symbol	Parameter	Threshold	Conditions	Min	Typ	Max	Units
V_{TH}	Reset Threshold Voltage	L	$T_A = +25^{\circ}\text{C}$	4.56	4.63	4.70	V
			$T_A = -40^{\circ}\text{C}$ to $+85^{\circ}\text{C}$	4.50		4.75	
		M	$T_A = +25^{\circ}\text{C}$	4.31	4.38	4.45	
			$T_A = -40^{\circ}\text{C}$ to $+85^{\circ}\text{C}$	4.25		4.50	
		J	$T_A = +25^{\circ}\text{C}$	3.93	4.00	4.06	
			$T_A = -40^{\circ}\text{C}$ to $+85^{\circ}\text{C}$	3.89		4.10	
		T	$T_A = +25^{\circ}\text{C}$	3.04	3.08	3.11	
			$T_A = -40^{\circ}\text{C}$ to $+85^{\circ}\text{C}$	3.00		3.15	
		S	$T_A = +25^{\circ}\text{C}$	2.89	2.93	2.96	
			$T_A = -40^{\circ}\text{C}$ to $+85^{\circ}\text{C}$	2.85		3.00	
		R	$T_A = +25^{\circ}\text{C}$	2.59	2.63	2.66	
			$T_A = -40^{\circ}\text{C}$ to $+85^{\circ}\text{C}$	2.55		2.70	
Z	$T_A = +25^{\circ}\text{C}$	2.28	2.32	2.35			
	$T_A = -40^{\circ}\text{C}$ to $+85^{\circ}\text{C}$	2.25		2.38			
Symbol	Parameter	Conditions		Min	Typ (Note 1)	Max	Units
	Reset Threshold Tempco				30		ppm/ $^{\circ}\text{C}$
t_{RPD}	V_{CC} to Reset Delay (Note 2)	$V_{CC} = V_{TH}$ to $(V_{TH} - 100\text{ mV})$			20		μs
t_{PURST}	Reset Active Timeout Period	$T_A = -40^{\circ}\text{C}$ to $+85^{\circ}\text{C}$		140	240	460	ms
V_{OL}	RESET Output Voltage Low (Push-pull, Active LOW, CAT130xx9)	$V_{CC} = V_{TH}$ min, $I_{SINK} = 1.2\text{ mA}$ R/S/T/Z				0.3	V
		$V_{CC} = V_{TH}$ min, $I_{SINK} = 3.2\text{ mA}$ J/L/M				0.4	
		$V_{CC} > 1.0\text{ V}$, $I_{SINK} = 50\text{ }\mu\text{A}$				0.3	
V_{OH}	RESET Output Voltage High (Push-pull, Active LOW, CAT130xx9)	$V_{CC} = V_{TH}$ max, $I_{SOURCE} = -500\text{ }\mu\text{A}$ R/S/T/Z		$0.8 V_{CC}$			V
		$V_{CC} = V_{TH}$ max, $I_{SOURCE} = -800\text{ }\mu\text{A}$ J/L/M		$V_{CC} - 1.5$			
V_{OL}	RESET Output Voltage Low (Push-pull, Active HIGH, CAT130xx1)	$V_{CC} > V_{TH}$ max, $I_{SINK} = 1.2\text{ mA}$ R/S/T/Z				0.3	V
		$V_{CC} > V_{TH}$ max, $I_{SINK} = 3.2\text{ mA}$ J/L/M				0.4	
V_{OH}	RESET Output Voltage High (Push-pull, Active HIGH, CAT130xx1)	$1.8\text{ V} < V_{CC} \leq V_{TH}$ min, $I_{SOURCE} = -150\text{ }\mu\text{A}$		$0.8 V_{CC}$			V

1. Production testing done at $T_A = +25^{\circ}\text{C}$; limits over temperature guaranteed by design only.
2. RESET output for the CAT130xx9; RESET output for the CAT130xx1.

CAT130xx

PIN DESCRIPTION

RESET/RESET: The reset output is available in two versions: CMOS Active Low (CAT130xx9) and CMOS Active High (CAT130xx1). Both versions are push-pull outputs for high efficiency.

DI: The serial data input pin accepts op-codes, addresses and data. The input data is latched on the rising edge of the SK clock input.

SK: The serial clock input pin accepts the clock provided by the host and used for synchronizing communication between host and CAT130xx device.

CS: The chip select input pin is used to enable/disable the CAT130xx. When CS is high, the device is selected and accepts op-codes, addresses and data. Upon receiving a Write or Erase instruction, the falling edge of CS will start the internal write cycle to the selected memory location.

ORG: The memory organization input selects the memory configuration as either register of 16 bits (ORG tied to V_{CC} or floating) or 8 bits (ORG connected to GND).

DEVICE OPERATION

The CAT130xx products combine the accurate voltage monitoring capabilities of a standalone voltage supervisor with the high quality and reliability of standard EEPROMs from ON Semiconductor.

Reset Controller Description

The reset signal is asserted LOW for the CAT130xx9 and HIGH for the CAT130xx1 when the power supply voltage falls below the threshold trip voltage and remains asserted for at least 140 ms (t_{PURST}) after the power supply voltage has risen above the threshold. Reset output timing is shown in Figure 2.

The CAT130xx devices protect μ Ps against brownout failure. Short duration V_{CC} transients of 4 μ sec or less and 100 mV amplitude typically do not generate a Reset pulse.

Figure 1 shows the maximum pulse duration of negative-going V_{CC} transients that do not cause a reset condition. As the amplitude of the transient goes further below the threshold (increasing $V_{TH} - V_{CC}$), the maximum pulse duration decreases. In this test, the V_{CC} starts from an

initial voltage of 0.5 V above the threshold and drops below it by the amplitude of the overdrive voltage ($V_{TH} - V_{CC}$).

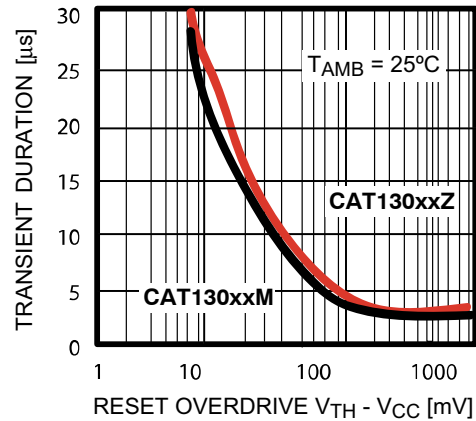

Figure 1. Maximum Transient Duration without Causing a Reset Pulse vs. Overdrive Voltage

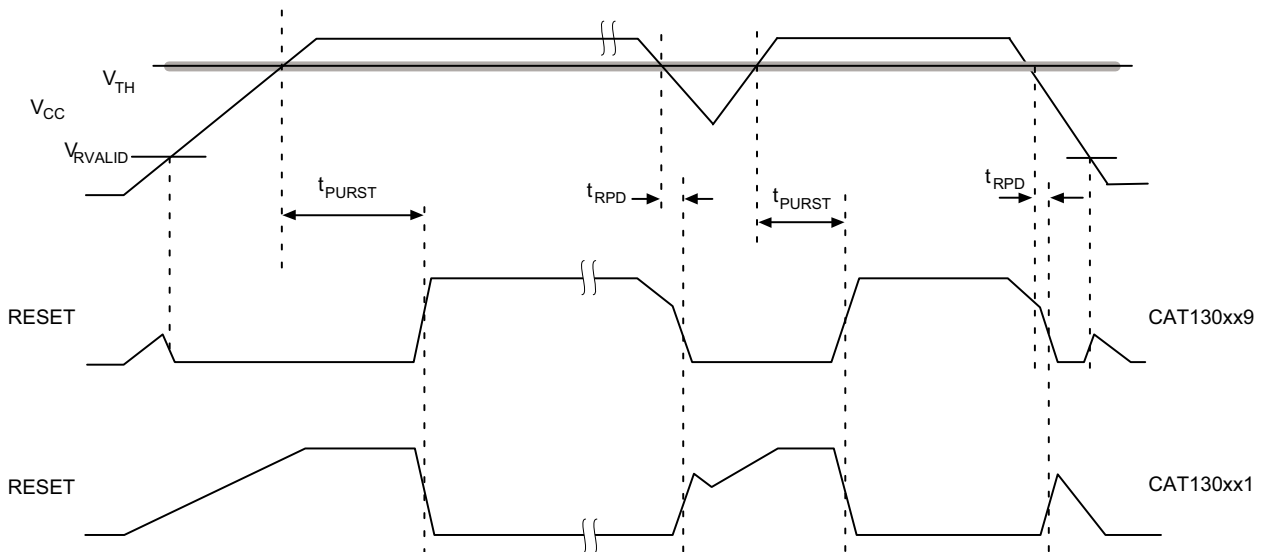

Figure 2. RESET Output Timing

CAT130xx

EMBEDDED EEPROM OPERATION

The CAT130xx has a nonvolatile embedded memory intended for use with industry standard microprocessors. The memory can be organized as either registers of 16 bits or 8 bits. The CAT130xx operates on a single power supply and will generate on chip the high voltage required during any write operation.

The format for all instructions sent to the device is a logical “1” start bit, a 2-bit (or 4-bit) opcode, 6-bit (13001) / 8-bit (13004) / 9-bit (13008) / 10-bit (13016) address (an additional bit when organized as x8) and for write operations a 16-bit data field (8-bit for x8 organization). The instruction format is shown in Instruction Set Table.

Table 7. INSTRUCTION SET

Instruction	Device	Start Bit	Opcode	Address		Data		Comments
				x 8	x 16	x 8	x 16	
READ	13001	1	10	A6-A0	A5-A0			Read Address AN-A0
	13004	1	10	A8-A0	A7-A0			
	13008	1	10	A9-A0	A8-A0			
	13016	1	10	A10-A0	A9-A0			
ERASE	13001	1	11	A6-A0	A5-A0			Clear Address AN-A0
	13004	1	11	A8-A0	A7-A0			
	13008	1	11	A9-A0	A8-A0			
	13016	1	11	A10-A0	A9-A0			
WRITE	13001	1	01	A6-A0	A5-A0	D7-D0	D15-D0	Write Address AN-A0
	13004	1	01	A8-A0	A7-A0	D7-D0	D15-D0	
	13008	1	01	A9-A0	A8-A0	D7-D0	D15-D0	
	13016	1	01	A10-A0	A9-A0	D7-D0	D15-D0	
EWEN	13001	1	00	11xxxxx	11xxxx			Write Enable
	13004	1	00	11xxxxxxx	11xxxxxxx			
	13008	1	00	11xxxxxxxxx	11xxxxxxxxx			
	13016	1	00	11xxxxxxxxxxx	11xxxxxxxxxxx			
EWDS	13001	1	00	00xxxxx	00xxxx			Write Disable
	13004	1	00	00xxxxxxx	00xxxxxxx			
	13008	1	00	00xxxxxxxxx	00xxxxxxxxx			
	13016	1	00	00xxxxxxxxxxx	00xxxxxxxxxxx			
ERAL	13001	1	00	10xxxxx	10xxxx			Clear All Addresses
	13004	1	00	10xxxxxxx	10xxxxxxx			
	13008	1	00	10xxxxxxxxx	10xxxxxxxxx			
	13016	1	00	10xxxxxxxxxxx	10xxxxxxxxxxx			
WRAL	13001	1	00	01xxxxx	01xxxx	D7-D0	D15-D0	Write All Address
	13004	1	00	01xxxxxxx	01xxxxxxx	D7-D0	D15-D0	
	13008	1	00	01xxxxxxxxx	01xxxxxxxxx	D7-D0	D15-D0	
	13016	1	00	01xxxxxxxxxxx	01xxxxxxxxxxx	D7-D0	D15-D0	

CAT130xx

Instructions, addresses, and write data are clocked into the DI pin on the rising edge of the clock (SK). The DO pin is normally in a high impedance state except when reading data from the device, or when checking the ready/busy status during a write operation. The serial communication protocol follows the timing shown in Figure 3.

The ready/busy status can be determined after the start of internal write cycle by selecting the device (CS high) and polling the DO pin; DO low indicates that the write operation is not completed, while DO high indicates that the device is ready for the next instruction. If necessary, the DO pin may be placed back into a high impedance state during chip select by shifting a dummy "1" into the DI pin. The DO pin will enter the high impedance state on the rising edge of the clock (SK). Placing the DO pin into the high impedance state is recommended in the applications where the DI pin and the DO pin are to be tied together to form a common DI/O pin. The Ready/Busy flag can be disabled only in Ready state; no change is allowed in Busy state.

Read

Upon receiving a READ command and an address (clocked into the DI pin), the DO pin of the CAT130xx will come out of the high impedance state and, after sending an initial dummy zero bit, will begin shifting out the data addressed (MSB first). The output data bits will toggle on the rising edge of the SK clock and are stable after the specified time delay (t_{PD0} or t_{PD1}). The READ instruction timing is illustrated in Figure 4.

For the CAT13004/08/16, after the initial data word has been shifted out and CS remains asserted with the SK clock continuing to toggle, the device will automatically increment to the next address and shift out the next data word in a sequential READ mode. As long as CS is continuously asserted and SK continues to toggle, the device will keep incrementing to the next address automatically until it reaches to the end of the address space, then loops back to address 0. In the sequential READ mode, only the initial data word is preceded by a dummy zero bit. All subsequent data words will follow without a dummy zero bit.

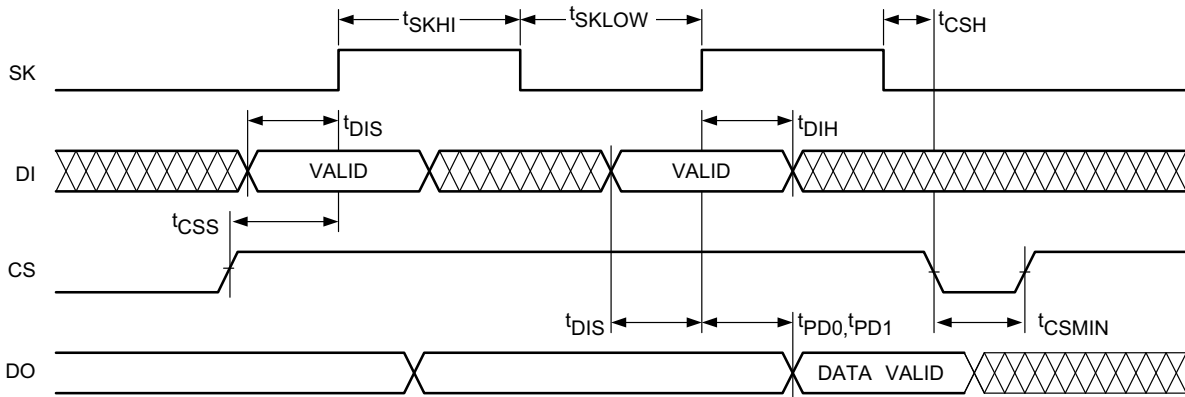

Figure 3. Synchronous Data Timing

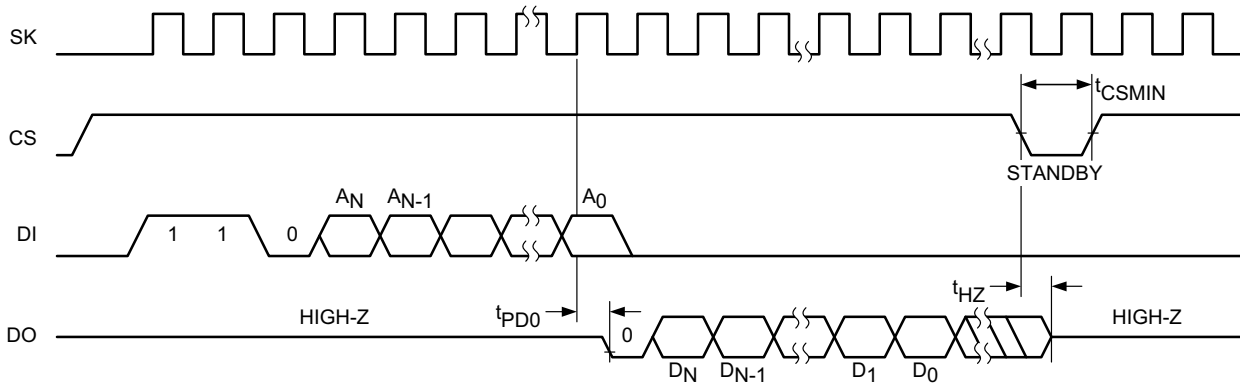

Figure 4. Read Instruction Timing

CAT130xx

Erase/Write Enable and Disable

The CAT130xx powers up in the write disable state. Any writing after power-up or after an EWDS (write disable) instruction must first be preceded by the EWEN (write enable) instruction. Once the write instruction is enabled, it will remain enabled until power to the device is removed, or the EWDS instruction is sent. The EWDS instruction can be used to disable all CAT130xx write and erase instructions, and will prevent any accidental writing or clearing of the device. Data can be read normally from the device regardless of the write enable/disable status. The EWEN and EWDS instructions timing is shown in Figure 5.

Write

After receiving a WRITE command (Figure 6), address and the data, the CS (Chip Select) pin must be deselected for a minimum of t_{CSMIN} . The falling edge of CS will start the self clocking for auto-clear and data store cycles on the memory location specified in the instruction. The clocking of the SK pin is not necessary after the device has entered the self clocking mode. The ready/busy status of the CAT130xx can be determined by selecting the device and polling the DO pin. Since this device features Auto-Clear before write, it is NOT necessary to erase a memory location before it is written into.

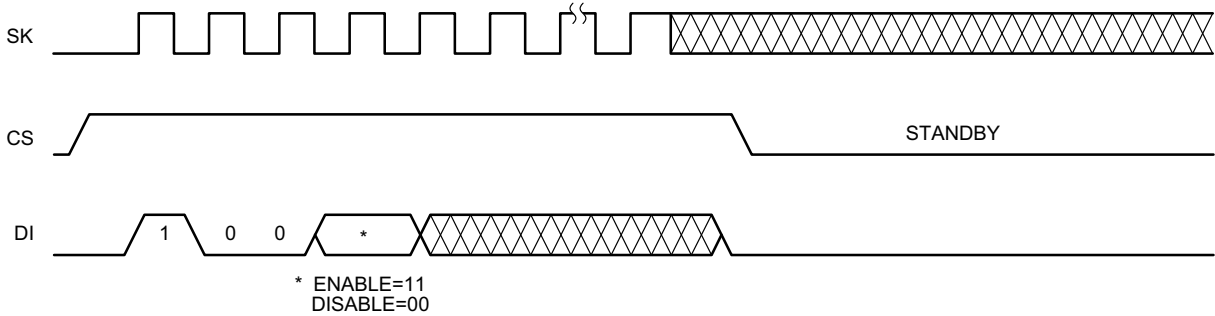

Figure 5. EWEN/EWDS Instruction Timing

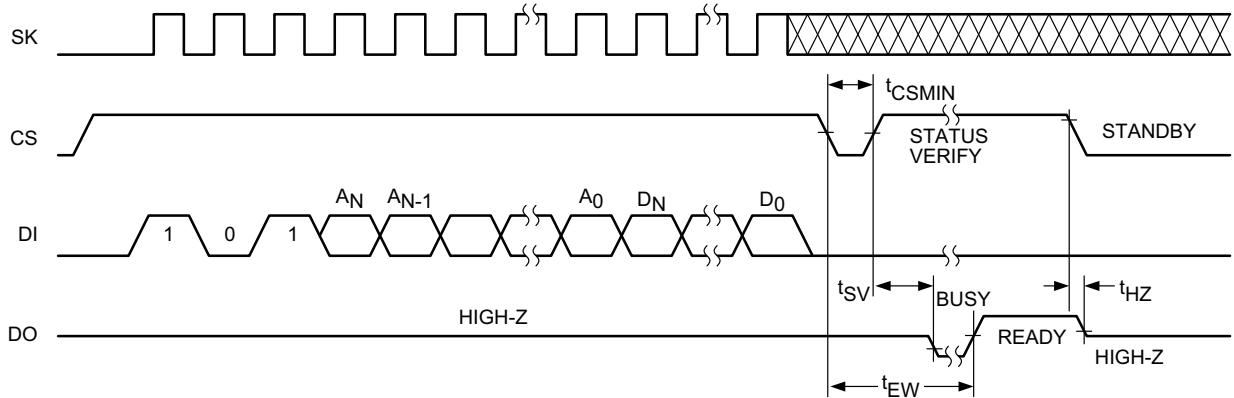

Figure 6. Write Instruction Timing

CAT130xx

Erase

Upon receiving an ERASE command and address, the CS (Chip Select) pin must be deasserted for a minimum of t_{CSMIN} (Figure 7). The falling edge of CS will start the self clocking clear cycle of the selected memory location. The clocking of the SK pin is not necessary after the device has entered the self clocking mode. The ready/busy status of the CAT130xx can be determined by selecting the device and polling the DO pin. Once cleared, the content of a cleared location returns to a logical "1" state.

Erase All

Upon receiving an ERAL command (Figure 8), the CS (Chip Select) pin must be deselected for a minimum of t_{CSMIN} . The falling edge of CS will start the self clocking clear cycle of all memory locations in the device. The clocking of the SK pin is not necessary after the device has entered the self clocking mode. The ready/busy status of the CAT130xx can be determined by selecting the device and polling the DO pin. Once cleared, the contents of all memory bits return to a logical "1" state.

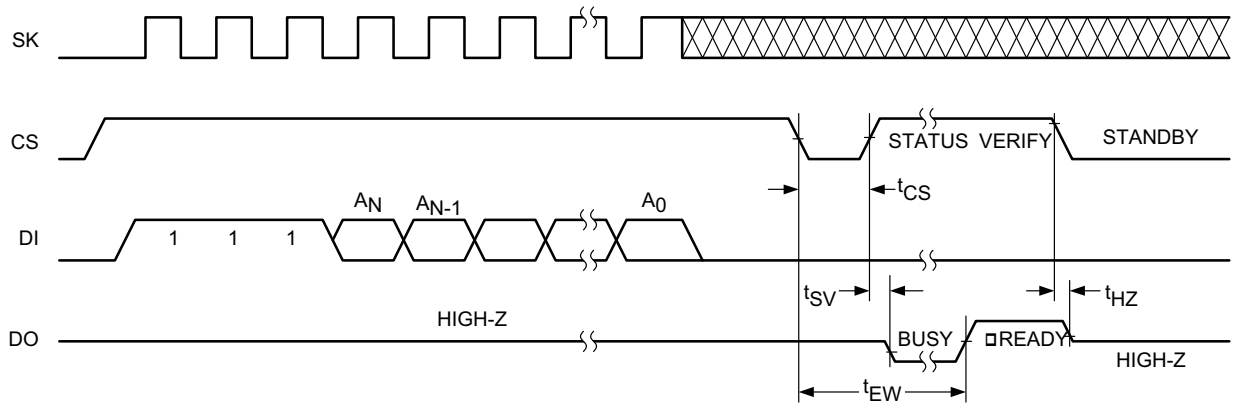

Figure 7. Erase Instruction Timing

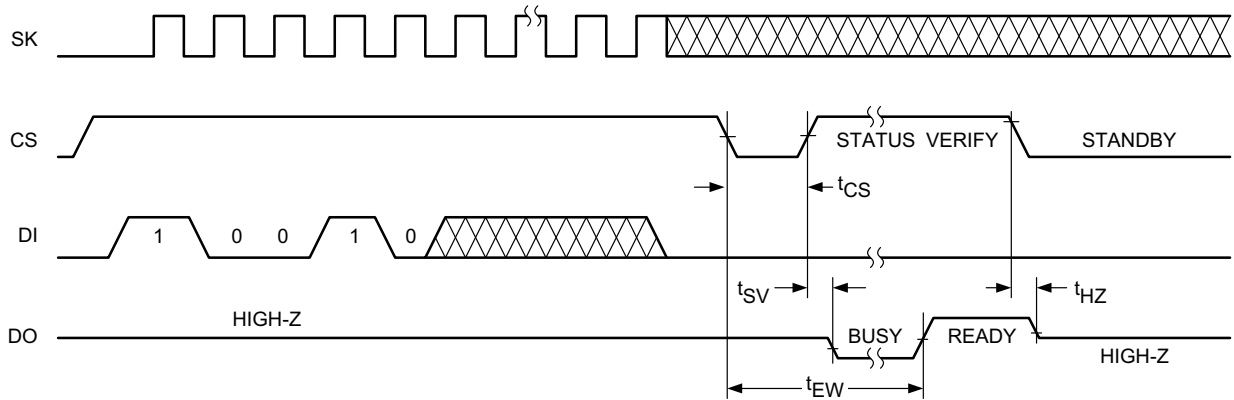

Figure 8. ERAL Instruction Timing

CAT130xx

Write All

Upon receiving a WRAL command and data, the CS (Chip Select) pin must be deselected for a minimum of t_{CSMIN} (Figure 9). The falling edge of CS will start the self clocking data write to all memory locations in the device. The clocking of the SK pin is not necessary after the device has entered the self clocking mode.

The ready/busy status of the CAT130xx can be determined by selecting the device and polling the DO pin. It is not necessary for all memory locations to be cleared before the WRAL command is executed.

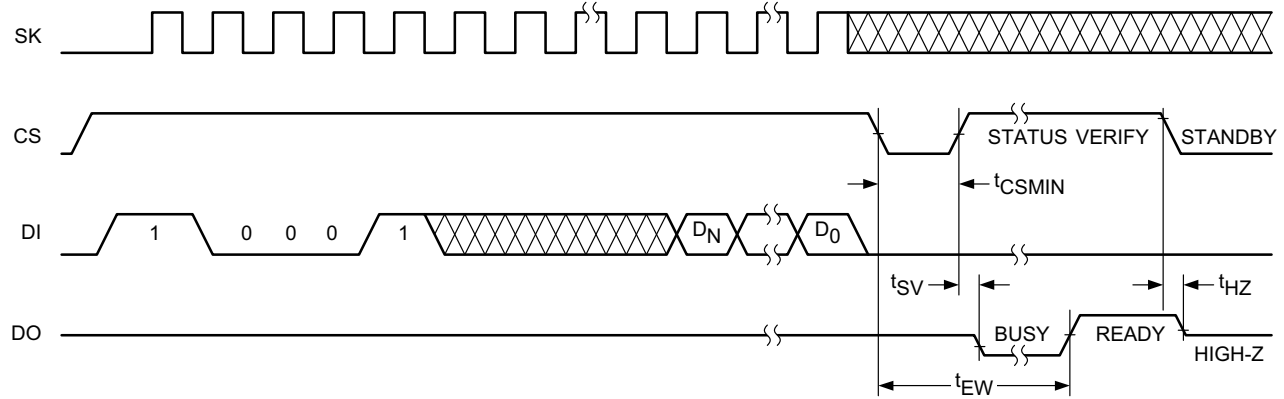

Figure 9. WRAL Instruction Timing

ORDERING INFORMATION

Orderable Part Numbers – CAT130xx Series (See Notes 1 – 5)			
Device	Reset Threshold Voltage	Package–Pins	Shipping
CAT130019SWI–GT3	2.85 to 3.00 V	SOIC–8	3000 Tape & Reel
CAT130019TWI–GT3	3.00 to 3.15 V		
CAT130019SWI–G	2.85 to 3.00 V		100 Tube

1. All packages are RoHS–compliant (Lead–free, Halogen–free).
2. The standard lead finish is NiPdAu.
3. For additional package and temperature options, please contact your nearest ON Semiconductor Sales office.
4. For 8–Kb and 16–Kb embedded EEPROM option availability please contact your nearest ON Semiconductor Sales office.
5. For detailed information and a breakdown of device nomenclature and numbering systems, please see the ON Semiconductor Device Nomenclature document, TND310/D, available at www.onsemi.com

CAT130xx

PACKAGE DIMENSIONS

SOIC 8, 150 mils
CASE 751BD-01
ISSUE 0

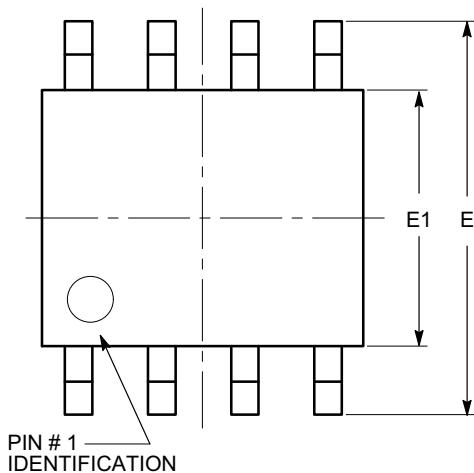

TOP VIEW

SYMBOL	MIN	NOM	MAX
A	1.35		1.75
A1	0.10		0.25
b	0.33		0.51
c	0.19		0.25
D	4.80		5.00
E	5.80		6.20
E1	3.80		4.00
e	1.27 BSC		
h	0.25		0.50
L	0.40		1.27
θ	0°		8°

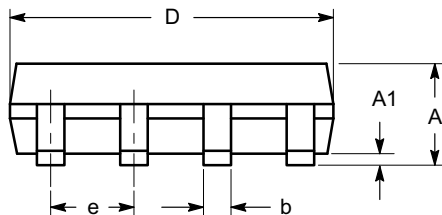

SIDE VIEW

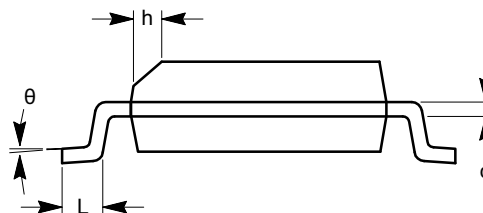

END VIEW

Notes:

- (1) All dimensions are in millimeters. Angles in degrees.
- (2) Complies with JEDEC MS-012.

ON Semiconductor and  are registered trademarks of Semiconductor Components Industries, LLC (SCILLC). SCILLC reserves the right to make changes without further notice to any products herein. SCILLC makes no warranty, representation or guarantee regarding the suitability of its products for any particular purpose, nor does SCILLC assume any liability arising out of the application or use of any product or circuit, and specifically disclaims any and all liability, including without limitation special, consequential or incidental damages. "Typical" parameters which may be provided in SCILLC data sheets and/or specifications can and do vary in different applications and actual performance may vary over time. All operating parameters, including "Typicals" must be validated for each customer application by customer's technical experts. SCILLC does not convey any license under its patent rights nor the rights of others. SCILLC products are not designed, intended, or authorized for use as components in systems intended for surgical implant into the body, or other applications intended to support or sustain life, or for any other application in which the failure of the SCILLC product could create a situation where personal injury or death may occur. Should Buyer purchase or use SCILLC products for any such unintended or unauthorized application, Buyer shall indemnify and hold SCILLC and its officers, employees, subsidiaries, affiliates, and distributors harmless against all claims, costs, damages, and expenses, and reasonable attorney fees arising out of, directly or indirectly, any claim of personal injury or death associated with such unintended or unauthorized use, even if such claim alleges that SCILLC was negligent regarding the design or manufacture of the part. SCILLC is an Equal Opportunity/Affirmative Action Employer. This literature is subject to all applicable copyright laws and is not for resale in any manner.

PUBLICATION ORDERING INFORMATION

LITERATURE FULFILLMENT:
Literature Distribution Center for ON Semiconductor
P.O. Box 5163, Denver, Colorado 80217 USA
Phone: 303-675-2175 or 800-344-3860 Toll Free USA/Canada
Fax: 303-675-2176 or 800-344-3867 Toll Free USA/Canada
Email: orderlit@onsemi.com

N. American Technical Support: 800-282-9855 Toll Free USA/Canada
Europe, Middle East and Africa Technical Support:
Phone: 421 33 790 2910
Japan Customer Focus Center
Phone: 81-3-5817-1050

ON Semiconductor Website: www.onsemi.com
Order Literature: <http://www.onsemi.com/orderlit>

For additional information, please contact your local Sales Representative

X-ON Electronics

Largest Supplier of Electrical and Electronic Components

Click to view similar products for [Supervisory Circuits](#) category:

Click to view products by [ON Semiconductor](#) manufacturer:

Other Similar products are found below :

[CAT1161LI-25-G](#) [CAT853STBI-T3](#) [CAT1026LI-30-G](#) [CAT1320LI-25-G](#) [TC54VN2402EMB713](#) [MCP1316T-44NE/OT](#) [MCP1316MT-45GE/OT](#) [MCP1316MT-23LI/OT](#) [MAX8997EWW+](#) [MAX6725AKASYD3-LF-T](#) [DS1232L](#) [NCV302HSN45T1G](#) [PT7M6130NLTA3EX](#) [PT7M7811STBEX-2017](#) [S-1000N28-I4T1U](#) [CAT1161LI-28-G](#) [MCP1321T-29AE/OT](#) [MCP1319MT-47QE/OT](#) [S-1000N23-I4T1U](#) [S-1000N19-I4T1U](#) [CAT824UTDI-GT3](#) [TC54VC2502ECB713](#) [PT7M6133NLTA3EX](#) [PT7M6127NLTA3EX](#) [VDA2510NTA](#) [AP0809ES3-r](#) [HG811RM4/TR](#) [MD7030C](#) [MD7033C](#) [MD7019](#) [MD7020](#) [MD7021](#) [MD7023](#) [MD7024](#) [MD7027](#) [MD7030](#) [MD7033](#) [MD7035](#) [MD7036](#) [MD7039](#) [MD7040](#) [MD7044](#) [MD7050](#) [MD7015](#) [MD7022](#) [MD7028](#) [MD7031](#) [MD7042](#) [MD7043](#) [MD7047](#)