

CD40106BC Hex Schmitt Trigger

General Description

The CD40106BC Hex Schmitt Trigger is a monolithic complementary MOS (CMOS) integrated circuit constructed with N and P-channel enhancement transistors. The positive and negative-going threshold voltages, V_{T+} and V_{T-} , show low variation with respect to temperature (typ 0.0005V/°C at $V_{DD} = 10V$), and hysteresis, $V_{T+} - V_{T-} \geq 0.2 V_{DD}$ is guaranteed.

All inputs are protected from damage due to static discharge by diode clamps to V_{DD} and V_{SS} .

Features

- Wide supply voltage range: 3V to 15V
- High noise immunity: $0.7 V_{DD}$ (typ.)
- Low power TTL compatibility: Fan out of 2 driving 74L or 1 driving 74LS
- Hysteresis: $0.4 V_{DD}$ (typ.), $0.2 V_{DD}$ guaranteed
- Equivalent to MM74C14
- Equivalent to MC14584B

Ordering Code:

Order Number	Package Number	Package Description
CD40106BCM	M14A	14-Lead Small Outline integrated Circuit (SOIC), JEDEC MS-120, 0.150" Narrow Body
CD40106BCN	N14A	14-Lead Plastic Dual-In-Line Package (PDIP), JEDEC MS-001, 0.300" Wide

Devices also available in Tape and Reel. Specify by appending the suffix letter "X" to the ordering code.

Connection Diagram

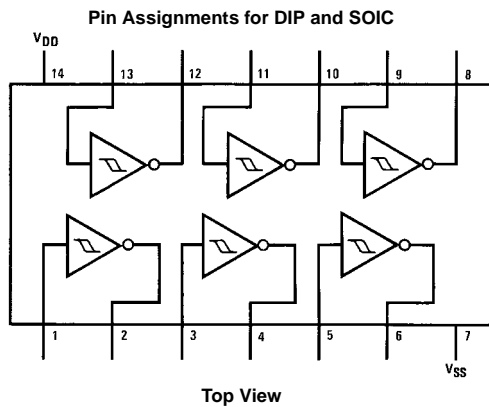

Schematic Diagram

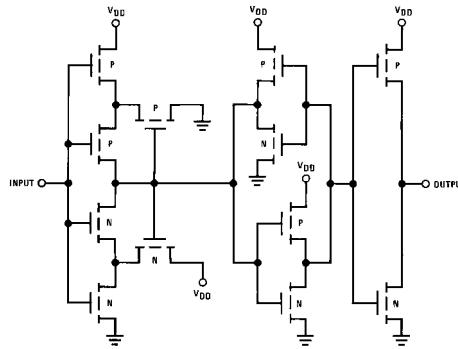

Absolute Maximum Ratings(Note 1)

(Note 2)

DC Supply Voltage (V_{DD})	-0.5 to +18 V_{DC}
Input Voltage (V_{IN})	-0.5 to V_{DD} +0.5 V_{DC}
Storage Temperature Range (T_S)	-65°C to +150°C
Power Dissipation (P_D)	
Dual-In-Line	700 mW
Small Outline	500 mW
Lead Temperature (T_L)	
(Soldering, 10 seconds)	260°C

Recommended Operating

Conditions (Note 2)

DC Supply Voltage (V_{DD})	3 to 15 V_{DC}
Input Voltage (V_{IN})	0 to V_{DD} V_{DC}
Operating Temperature Range (T_A)	-40°C to +85°C

Note 1: "Absolute Maximum Ratings" are those values beyond which the safety of the device cannot be guaranteed. They are not meant to imply that the devices should be operated at these limits. The table of "Recommended Operating Conditions" and "Electrical Characteristics" provides conditions for actual device operation.

Note 2: $V_{SS} = 0V$ unless otherwise specified.

DC Electrical Characteristics (Note 3)

Symbol	Parameter	Conditions	-40°C		+25°C			+85°C		Units
			Min	Max	Min	Typ	Max	Min	Max	
I_{DD}	Quiescent Device Current	$V_{DD} = 5V$		4.0				4.0	30	μA
		$V_{DD} = 10V$		8.0				8.0	60	μA
		$V_{DD} = 15V$		16.0				16.0	120	μA
V_{OL}	LOW Level Output Voltage	$ I_O < 1 \mu A$								
		$V_{DD} = 5V$		0.05				0.05	0.05	V
		$V_{DD} = 10V$		0.05				0.05	0.05	V
V_{OH}	HIGH Level Output Voltage	$ I_O < 1 \mu A$								
		$V_{DD} = 5V$	4.95		4.95	5		4.95		V
		$V_{DD} = 10V$	9.95		9.95	10		9.95		V
V_{T-}	Negative-Going Threshold Voltage	$V_{DD} = 5V, V_O = 4.5V$	0.7	2.0	0.7	1.4	2.0	0.7	2.0	V
		$V_{DD} = 10V, V_O = 9V$	1.4	4.0	1.4	3.2	4.0	1.4	4.0	V
		$V_{DD} = 15V, V_O = 13.5V$	2.1	6.0	2.1	5.0	6.0	2.1	6.0	V
V_{T+}	Positive-Going Threshold Voltage	$V_{DD} = 5V, V_O = 0.5V$	3.0	4.3	3.0	3.6	4.3	3.0	4.3	V
		$V_{DD} = 10V, V_O = 1V$	6.0	8.6	6.0	6.8	8.6	6.0	8.6	V
		$V_{DD} = 15V, V_O = 1.5V$	9.0	12.9	9.0	10.0	12.9	9.0	12.9	V
V_H	Hysteresis ($V_{T+} - V_{T-}$) Voltage	$V_{DD} = 5V$	1.0	3.6	1.0	2.2	3.6	1.0	3.6	V
		$V_{DD} = 10V$	2.0	7.2	2.0	3.6	7.2	2.0	7.2	V
		$V_{DD} = 15V$	3.0	10.8	3.0	5.0	10.8	3.0	10.8	V
I_{OL}	LOW Level Output Current (Note 3)	$V_{DD} = 5V, V_O = 0.4V$	0.52		0.44	0.88		0.36		mA
		$V_{DD} = 10V, V_O = 0.5V$	1.3		1.1	2.25		0.9		mA
		$V_{DD} = 15V, V_O = 1.5V$	3.6		3.0	8.8		2.4		mA
I_{OH}	HIGH Level Output Current (Note 3)	$V_{DD} = 5V, V_O = 4.6V$	-0.52		-0.44	-0.88		-0.36		mA
		$V_{DD} = 10V, V_O = 9.5V$	-1.3		-1.1	-2.25		-0.9		mA
		$V_{DD} = 15V, V_O = 13.5V$	-3.6		-3.0	-8.8		-2.4		mA
I_{IN}	Input Current	$V_{DD} = 15V, V_{IN} = 0V$		-0.30		-10^{-5}	-0.30		-1.0	μA
		$V_{DD} = 15V, V_{IN} = 15V$		0.30		10^{-5}	0.30		1.0	μA

Note 3: I_{OH} and I_{OL} are tested one output at a time.

AC Electrical Characteristics (Note 4)

T_A = 25°C, C_L = 50 pF, R_L = 200k, t_r and t_f = 20 ns, unless otherwise specified

Symbol	Parameter	Conditions	Min	Typ	Max	Units
t _{PHL} or t _{PLH}	Propagation Delay Time from Input to Output	V _{DD} = 5V V _{DD} = 10V V _{DD} = 15V		220 80 70	400 200 160	ns
t _{THL} or t _{TLH}	Transition Time	V _{DD} = 5V V _{DD} = 10V V _{DD} = 15V		100 50 40	200 100 80	ns
C _{IN}	Average Input Capacitance	Any Input		5	7.5	pF
C _{PD}	Power Dissipation Capacity	Any Gate (Note 5)		14		pF

Note 4: AC Parameters are guaranteed by DC correlated testing.

Note 5: C_{PD} determines the no load ac power consumption of any CMOS device. For complete explanation see 74C Family Characteristics Application Note, AN-90.

Switching Time Waveforms

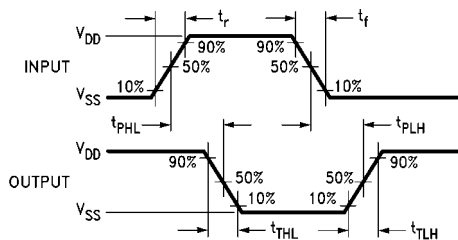

t_r = t_f = 20 ns

Typical Applications

Low Power Oscillator

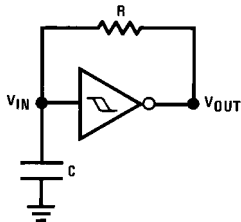

$$t_1 \approx RC \ln \frac{V_{T+}}{V_{T-}}$$

$$t_2 \approx RC \ln \frac{V_{DD} - V_{T-}}{V_{DD} - V_{T+}}$$

$$f \approx \frac{1}{RC \ln \frac{V_{T+} (V_{DD} - V_{T-})}{V_{T-} (V_{DD} - V_{T+})}}$$

Note: The equations assume
t₁ + t₂ >> t_{PHL} + t_{PLH}

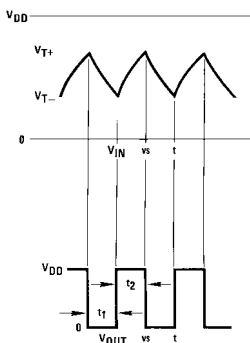

Typical Performance Characteristics

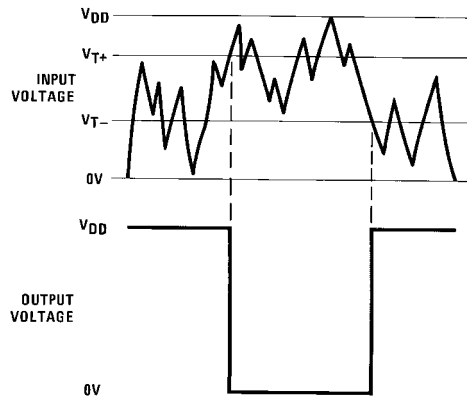
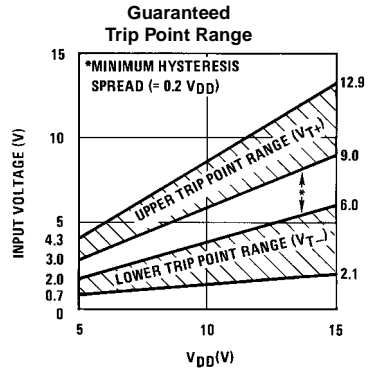
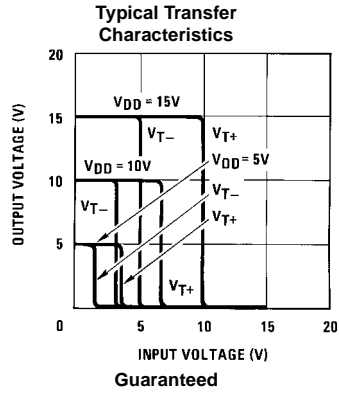

Physical Dimensions inches (millimeters) unless otherwise noted

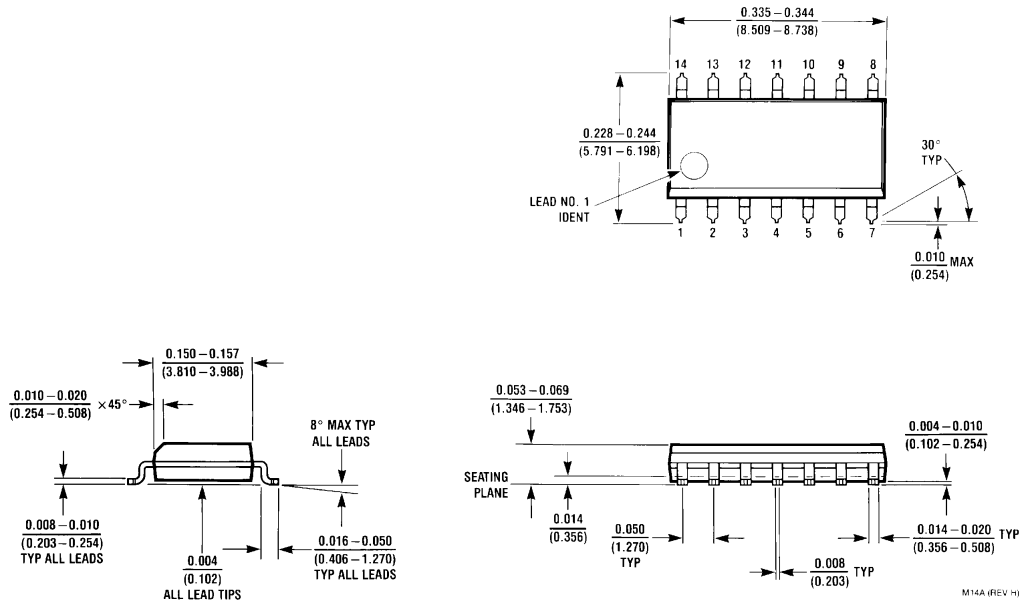

**16-Lead Small Outline Integrated Circuit (SOIC), JEDEC MS-120, 0.150" Narrow Body
Package Number M14A**

Physical Dimensions inches (millimeters) unless otherwise noted (Continued)

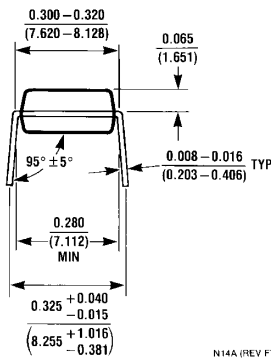
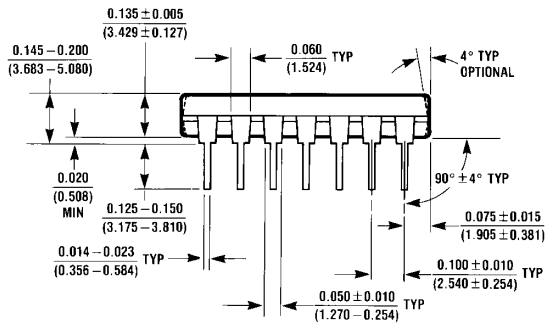
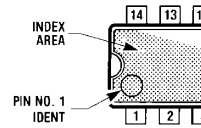
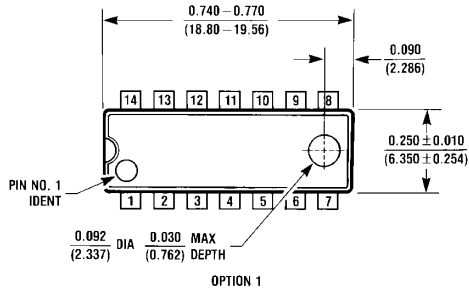

N14A (REV F)

14-Lead Plastic Dual-In-Line Package (PDIP), JEDEC MS-001, 0.300" Wide Package Number N14A

LIFE SUPPORT POLICY

FAIRCHILD'S PRODUCTS ARE NOT AUTHORIZED FOR USE AS CRITICAL COMPONENTS IN LIFE SUPPORT DEVICES OR SYSTEMS WITHOUT THE EXPRESS WRITTEN APPROVAL OF THE PRESIDENT OF FAIRCHILD SEMICONDUCTOR CORPORATION. As used herein:

1. Life support devices or systems are devices or systems which, (a) are intended for surgical implant into the body, or (b) support or sustain life, and (c) whose failure to perform when properly used in accordance with instructions for use provided in the labeling, can be reasonably expected to result in a significant injury to the user.
2. A critical component in any component of a life support device or system whose failure to perform can be reasonably expected to cause the failure of the life support device or system, or to affect its safety or effectiveness.

www.fairchildsemi.com

X-ON Electronics

Largest Supplier of Electrical and Electronic Components

Click to view similar products for [Inverters](#) category:

Click to view products by [ON Semiconductor](#) manufacturer:

Other Similar products are found below :

[E5-652Z](#) [NLX2G04BMX1TCG](#) [CD4009UBE](#) [TC4584BFN](#) [NL17SG14AMUTCG](#) [NLU2GU04BMX1TCG](#) [NLV17SZ14DFT2G](#)
[TC74VHC04FK\(EL,K\)](#) [NLV74HC04ADTR2G](#) [NLU1G04AMUTCG](#) [NLX2G04CMUTCG](#) [NLX2G04AMUTCG](#) [NLV27WZ04DFT1G](#)
[NLU1G04CMUTCG](#) [NL17SZU04P5T5G](#) [74LVC06ADTR2G](#) [74LVC04ADR2G](#) [NLV37WZ04USG](#) [NLX3G14FMUTCG](#) [NL17SZ04P5T5G](#)
[NL17SG14P5T5G](#) [NLV17SG14DFT2G](#) [NLVHC1G04DFT2G](#) [MC14069UBD](#) [NLU3G14CMX1TCG](#) [NLX2G14BMX1TCG](#)
[NLX2GU04AMX1TCG](#) [74HCT04DT](#) [74HCT14DT](#) [74LCX14FT\(AJ\)](#) [TC7S14F\(TE85L,F\)](#) [MM74HC14MTCX](#) [74VHC14MX](#) [BU4069UBF-](#)
[E2](#) [EMPP008Z](#) [NC7WZ14P6X](#) [NL27WZU04DTT1G](#) [NLU3G14MUTAG](#) [NLV74AC14DTR2G](#) [SN74HCT04DE4](#) [ODE-3-120023-1F12](#)
[74LVC2G04GW-Q100H](#) [74VHCT04AM](#) [TC7SH04F,LJ\(CT](#) [JM38510/30003BCA](#) [CD74HC14M96](#) [TC7W14FK,LF](#) [TC7WH04FU,LJ\(CT](#)
[74VHC14MTCX](#) [74LVC2G14FZ4-7](#)