

MOSFET - Power for 1-Cell Lithium-ion Battery Protection



ON Semiconductor®

www.onsemi.com

EFC2K103NUZ 12 V, 1.8 mΩ, 40 A, Dual N-Channel

This power MOSFET features a low on-state resistance. This device is suitable for applications such as power switches of portable machines. Best suited for 1-cell lithium-ion battery applications.

Features

- 2.5 V drive
- Common-Drain type
- ESD Diode-Protected Gate
- Pb-Free, Halogen Free and RoHS Compliance

Typical Applications

- 1-Cell Lithium-ion Battery Charging and Discharging Switch

SPECIFICATIONS

ABSOLUTE MAXIMUM RATINGS at $T_A = 25^\circ\text{C}$

Parameter	Symbol	Value	Unit
Source to Source Voltage	V_{SSS}	12	V
Gate to Source Voltage	V_{GSS}	± 8	V
Source Current (DC)	I_S	40	A
Source Current (Pulse) $PW \leq 10 \mu\text{s}$, Duty Cycle $\leq 1\%$	I_{SP}	140	A
Total Dissipation (Note 1)	P_T	3.3	W
Junction Temperature	T_J	150	$^\circ\text{C}$
Storage Temperature	T_{stg}	-55 to +150	$^\circ\text{C}$

Stresses exceeding those listed in the Maximum Ratings table may damage the device. If any of these limits are exceeded, device functionality should not be assumed, damage may occur and reliability may be affected.

THERMAL RESISTANCE MAXIMUM RATINGS

Parameter	Symbol	Value	Unit
Junction to Ambient (Note 1)	$R_{\theta JA}$	37	$^\circ\text{C/W}$

1. Surface mounted on ceramic substrate ($5000 \text{ mm}^2 \times 0.8 \text{ mm}$)

V_{SSS}	$R_{SS(ON)} \text{ MAX}$	$I_S \text{ MAX}$
12 V	1.8 mΩ @ 4.5 V	40 A
	1.9 mΩ @ 3.8 V	
	2.6 mΩ @ 3.1 V	
	4.2 mΩ @ 2.5 V	

ELECTRICAL CONNECTION N-Channel

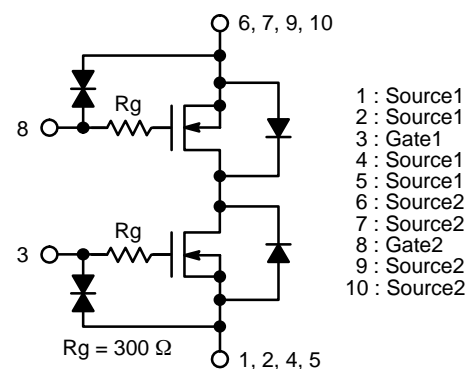

PIN ASSIGNMENT

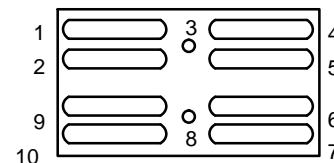

MARKING DIAGRAM

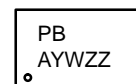
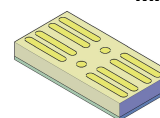

WLCSP10
3.54x1.77x0.140
CASE 567XB

PB = Specific Device Code
A = Assembly Location
Y = Year
W = Work Week
ZZ = Assembly Lot

ORDERING INFORMATION

See detailed ordering, marking and shipping information in the package dimensions section on page 2 of this data sheet.

EFC2K103NUZ

ELECTRICAL CHARACTERISTICS at $T_A = 25^\circ\text{C}$

Parameter	Symbol	Conditions	Value			Unit
			Min	Typ	Max	
Source to Source Breakdown Voltage	$V_{(BR)SSS}$	$I_S = 1 \text{ mA}, V_{GS} = 0 \text{ V}$ Test Circuit 1	12	–	–	V
Zero Gate Voltage Source Current	I_{SSS}	$V_{SS} = 10 \text{ V}, V_{GS} = 0 \text{ V}$ Test Circuit 1	–	–	1	μA
Gate to Source Leakage Current	I_{GSS}	$V_{GS} = \pm 8 \text{ V}, V_{SS} = 0 \text{ V}$ Test Circuit 2	–	–	± 1	μA
Gate Threshold Voltage	$V_{GS(th)}$	$V_{SS} = 6 \text{ V}, I_S = 1 \text{ mA}$ Test Circuit 3	0.4	–	1.3	V
Static Source to Source On-State Resistance	$R_{SS(on)}$	$I_S = 5 \text{ A}, V_{GS} = 4.5 \text{ V}$ Test Circuit 4	0.8	1.25	1.8	$\text{m}\Omega$
		$I_S = 5 \text{ A}, V_{GS} = 3.8 \text{ V}$ Test Circuit 4	0.85	1.35	1.9	$\text{m}\Omega$
		$I_S = 5 \text{ A}, V_{GS} = 3.1 \text{ V}$ Test Circuit 4	1.0	1.7	2.6	$\text{m}\Omega$
		$I_S = 5 \text{ A}, V_{GS} = 2.5 \text{ V}$ Test Circuit 4	1.2	2.1	4.2	$\text{m}\Omega$
Turn-ON Delay Time	$t_d(on)$	$V_{SS} = 6 \text{ V}, V_{GS} = 3.8 \text{ V}, I_S = 5 \text{ A},$ $R_G = 10 \text{ k}\Omega$ Test Circuit 5	–	25	–	μs
Rise Time	t_r		–	100	–	μs
Turn-OFF Delay Time	$t_d(off)$		–	165	–	μs
Fall Time	t_f		–	148	–	μs
Total Gate Charge	Q_g	$V_{SS} = 6 \text{ V}, V_{GS} = 3.8 \text{ V}, I_S = 5 \text{ A}$ Test Circuit 6	–	62	–	nC
Forward Source to Source Voltage	$V_{F(S-S)}$	$I_S = 3 \text{ A}, V_{GS} = 0 \text{ V}$ Test Circuit 7	–	0.75	1.2	V

Product parametric performance is indicated in the Electrical Characteristics for the listed test conditions, unless otherwise noted. Product performance may not be indicated by the Electrical Characteristics if operated under different conditions.

ORDERING INFORMATION

Device	Marking	Package	Shipping (Qty / Packing) [†]
EFC2K103NUZTDG	PB	WLCSP10, $3.54 \times 1.77 \times 0.140$ (Pb-Free / Halogen Free)	5,000 / Tape & Reel

[†]For information on tape and reel specifications, including part orientation and tape sizes, please refer to our Tape and Reel Packaging Specifications Brochure, BRD8011/D.

TYPICAL CHARACTERISTICS

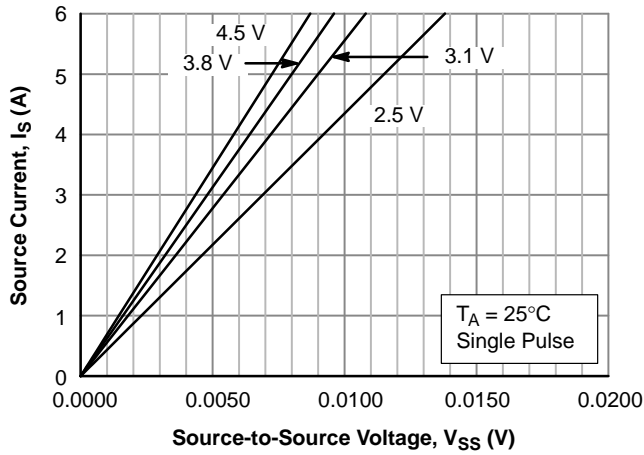

Figure 1. $I_S - V_{SS}$

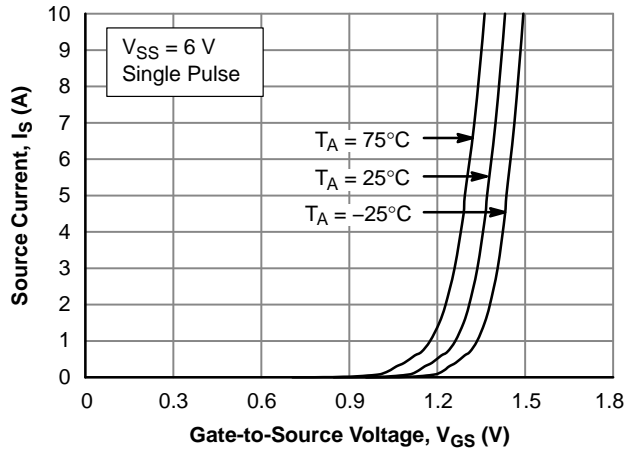

Figure 2. $I_S - V_{GS}$

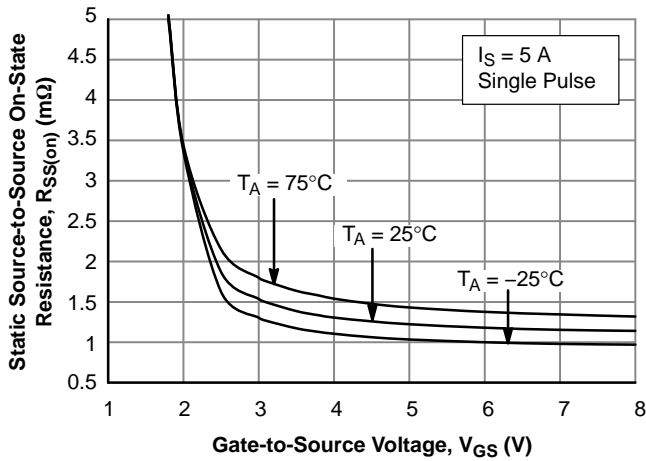

Figure 3. $R_{SS(on)} - V_{GS}$

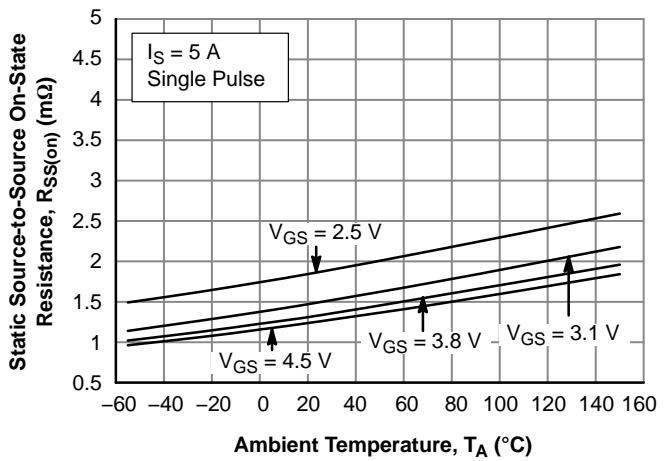

Figure 4. $R_{SS(on)} - T_A$

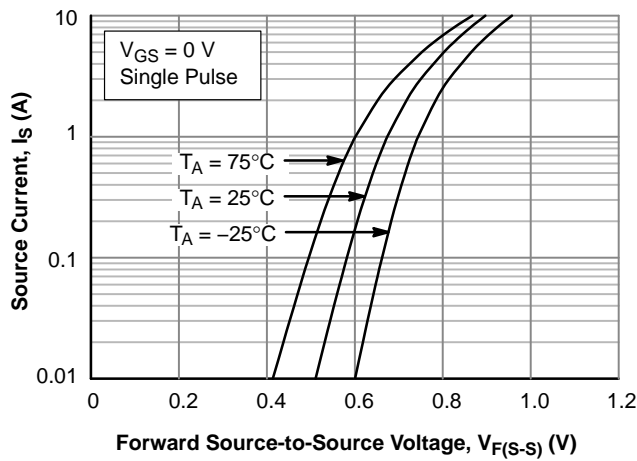

Figure 5. $I_S - V_{F(S-S)}$

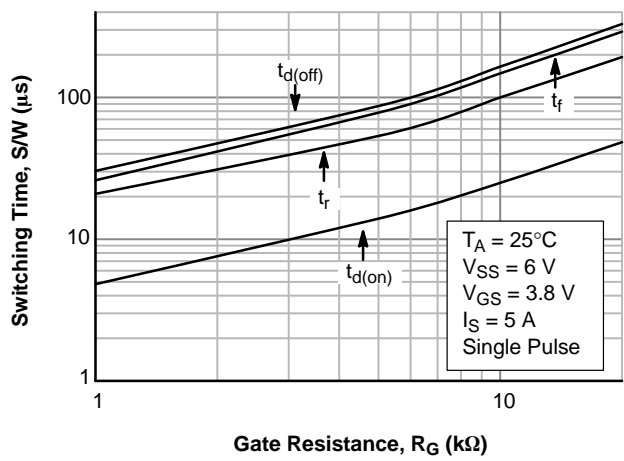

Figure 6. SW Time - R_G

EFC2K103NUZ

TYPICAL CHARACTERISTICS (Continued)

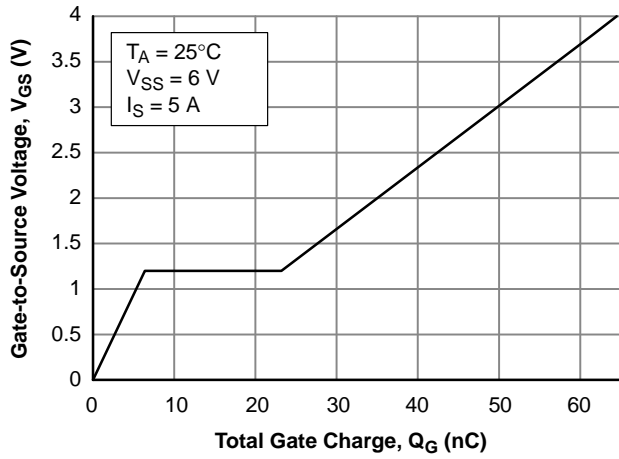

Figure 7. $V_{GS} - Q_G$

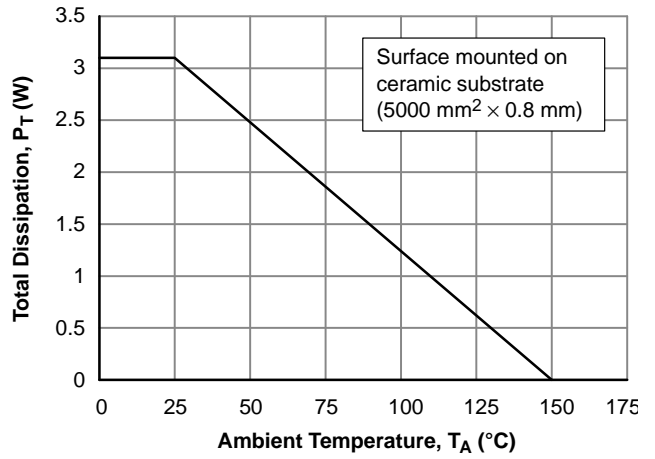

Figure 8. $P_T - T_A$

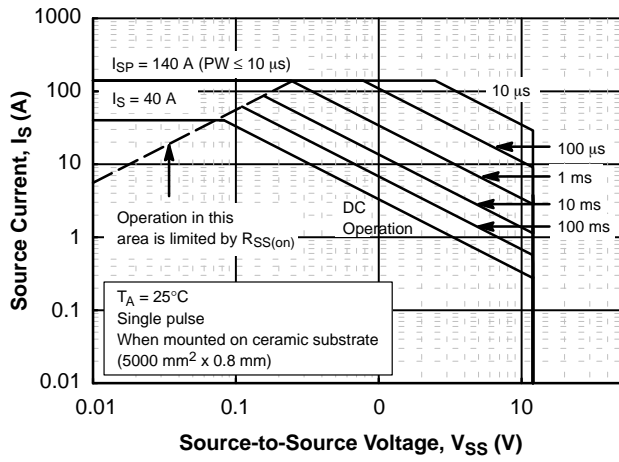

Figure 9. Safe Operating Area

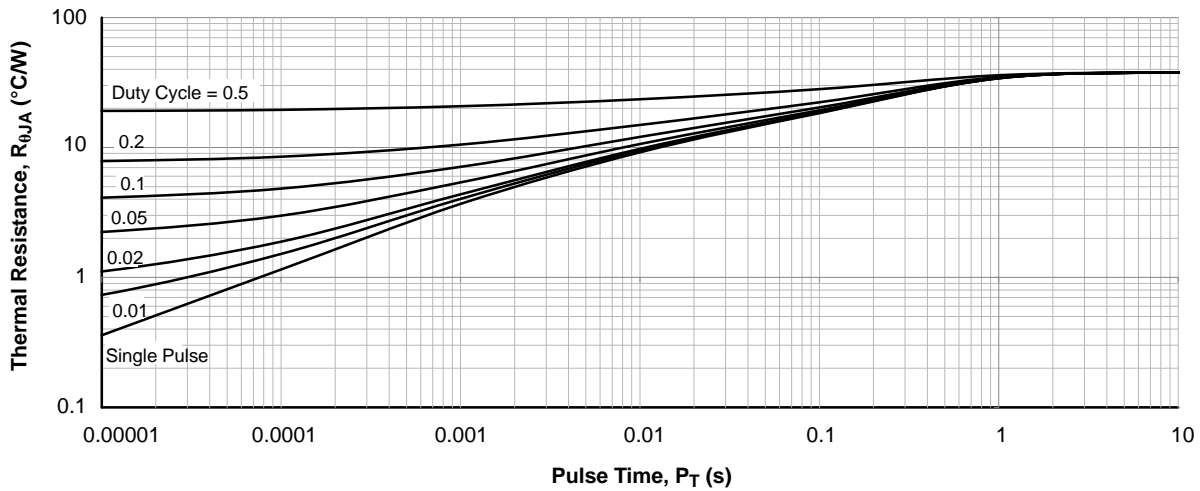

Figure 10. Thermal Response

TEST CIRCUITS ARE EXAMPLES OF MEASURING FET1 SIDE

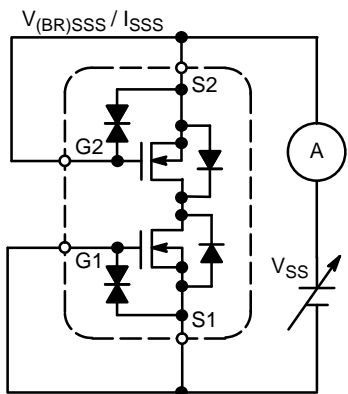

Figure 11. Test Circuit 1

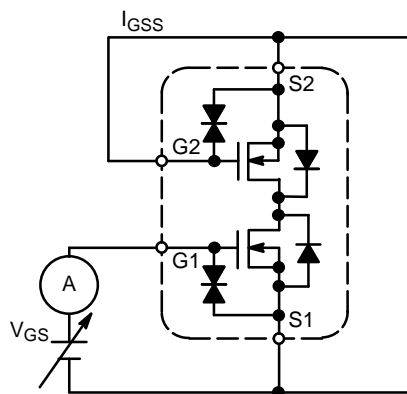
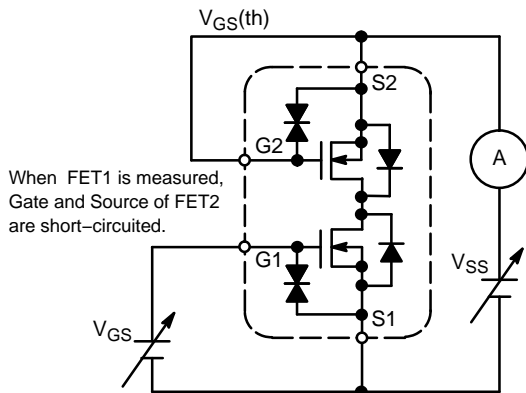

Figure 12. Test Circuit 2

When FET1 is measured, Gate and Source of FET2 are short-circuited.



When FET1 is measured, Gate and Source of FET2 are short-circuited.

Figure 13. Test Circuit 3

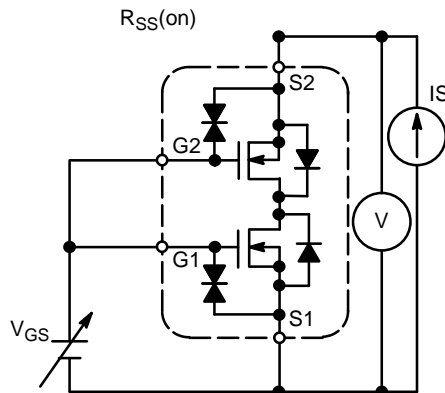
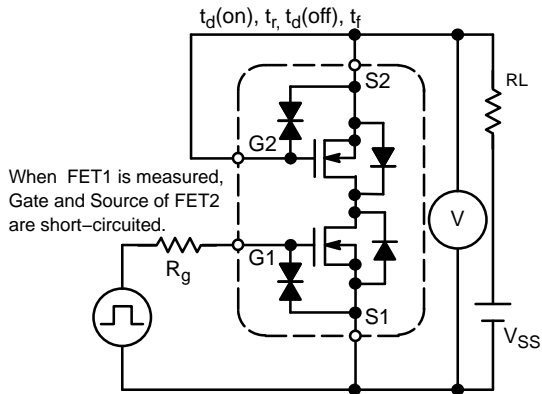
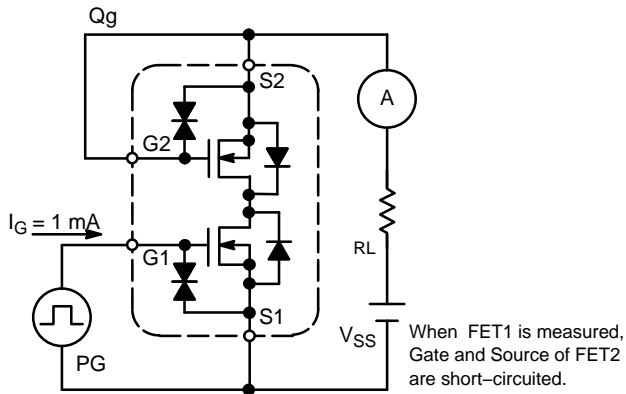

Figure 14. Test Circuit 4



When FET1 is measured, Gate and Source of FET2 are short-circuited.

Figure 15. Test Circuit 5



When FET1 is measured, Gate and Source of FET2 are short-circuited.

Figure 16. Test Circuit 6

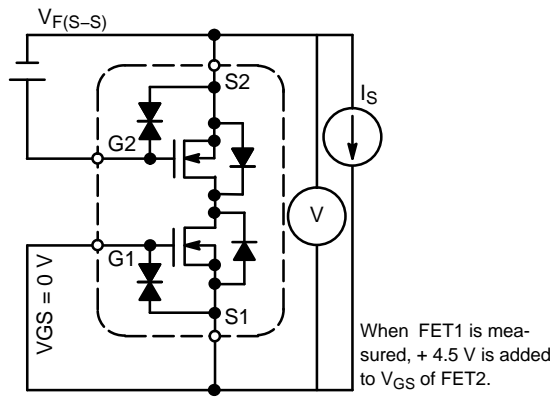

Figure 17. Test Circuit
7

NOTE: When FET2 is measured, the position of FET1 and FET2 is switched.

NOTE: Since the EFC2K103NUZ is a MOSFET product, please avoid using this device in the vicinity of highly charged objects. Please contact sales for use except the designated application.

MECHANICAL CASE OUTLINE

PACKAGE DIMENSIONS

ON Semiconductor®

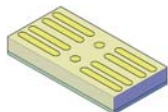

WLCSP10, 3.54x1.77x0.14
CASE 567XB
ISSUE O

DATE 09 OCT 2018

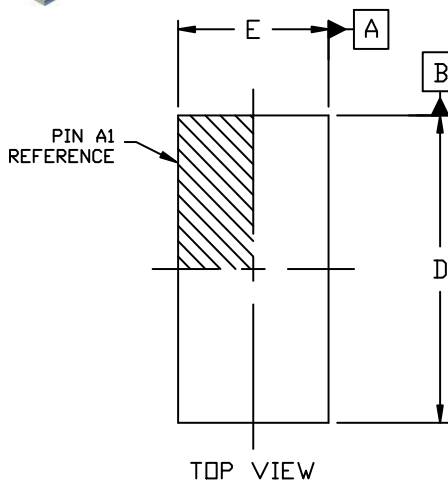

NOTES:

1. DIMENSIONING AND TOLERANCING PER ASME Y14.5M, 1994.
2. CONTROLLING DIMENSION: MILLIMETERS

DIM	MILLIMETERS		
	MIN.	NOM.	MAX.
A	0.11	0.14	0.17
A3	0.04 REF		
b	0.22	0.25	0.28
b1	0.17	0.20	0.23
b2	1.29	1.32	1.35
D	3.51	3.54	3.57
E	1.74	1.77	1.80
e	0.45 BSC		
e1	0.35 BSC		
e2	0.80 BSC		
e3	1.035 BSC		

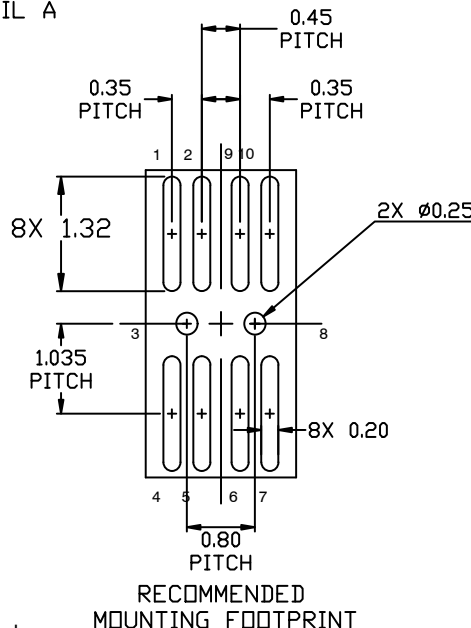
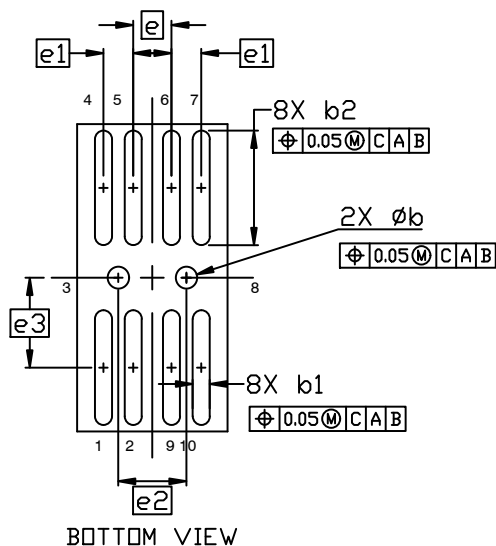
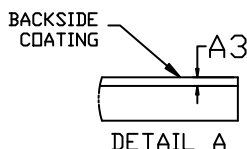
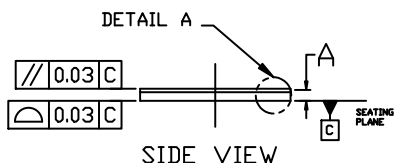

GENERIC MARKING DIAGRAM*

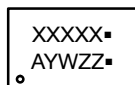

XXXX = Specific Device Code
 A = Assembly Location
 Y = Year
 W = Work Week
 ZZ = Assembly Lot Code
 ■ = Pb-Free Package

(Note: Microdot may be in either location)

*This information is generic. Please refer to device data sheet for actual part marking. Pb-Free indicator, "G" or microdot "■", may or may not be present. Some products may not follow the Generic Marking.

DOCUMENT NUMBER:	98AON98952G	Electronic versions are uncontrolled except when accessed directly from the Document Repository. Printed versions are uncontrolled except when stamped "CONTROLLED COPY" in red.
DESCRIPTION:	WLCSP10, 3.54x1.77x0.14	PAGE 1 OF 1

ON Semiconductor and are trademarks of Semiconductor Components Industries, LLC dba ON Semiconductor or its subsidiaries in the United States and/or other countries. ON Semiconductor reserves the right to make changes without further notice to any products herein. ON Semiconductor makes no warranty, representation or guarantee regarding the suitability of its products for any particular purpose, nor does ON Semiconductor assume any liability arising out of the application or use of any product or circuit, and specifically disclaims any and all liability, including without limitation special, consequential or incidental damages. ON Semiconductor does not convey any license under its patent rights nor the rights of others.

onsemi, **Onsemi**, and other names, marks, and brands are registered and/or common law trademarks of Semiconductor Components Industries, LLC dba "**onsemi**" or its affiliates and/or subsidiaries in the United States and/or other countries. **onsemi** owns the rights to a number of patents, trademarks, copyrights, trade secrets, and other intellectual property. A listing of **onsemi**'s product/patent coverage may be accessed at www.onsemi.com/site/pdf/Patent-Marking.pdf. **onsemi** reserves the right to make changes at any time to any products or information herein, without notice. The information herein is provided "as-is" and **onsemi** makes no warranty, representation or guarantee regarding the accuracy of the information, product features, availability, functionality, or suitability of its products for any particular purpose, nor does **onsemi** assume any liability arising out of the application or use of any product or circuit, and specifically disclaims any and all liability, including without limitation special, consequential or incidental damages. Buyer is responsible for its products and applications using **onsemi** products, including compliance with all laws, regulations and safety requirements or standards, regardless of any support or applications information provided by **onsemi**. "Typical" parameters which may be provided in **onsemi** data sheets and/or specifications can and do vary in different applications and actual performance may vary over time. All operating parameters, including "Typicals" must be validated for each customer application by customer's technical experts. **onsemi** does not convey any license under any of its intellectual property rights nor the rights of others. **onsemi** products are not designed, intended, or authorized for use as a critical component in life support systems or any FDA Class 3 medical devices or medical devices with a same or similar classification in a foreign jurisdiction or any devices intended for implantation in the human body. Should Buyer purchase or use **onsemi** products for any such unintended or unauthorized application, Buyer shall indemnify and hold **onsemi** and its officers, employees, subsidiaries, affiliates, and distributors harmless against all claims, costs, damages, and expenses, and reasonable attorney fees arising out of, directly or indirectly, any claim of personal injury or death associated with such unintended or unauthorized use, even if such claim alleges that **onsemi** was negligent regarding the design or manufacture of the part. **onsemi** is an Equal Opportunity/Affirmative Action Employer. This literature is subject to all applicable copyright laws and is not for resale in any manner.

PUBLICATION ORDERING INFORMATION

LITERATURE FULFILLMENT:

Email Requests to: orderlit@onsemi.com

onsemi Website: www.onsemi.com

TECHNICAL SUPPORT

North American Technical Support:

Voice Mail: 1 800-282-9855 Toll Free USA/Canada

Phone: 011 421 33 790 2910

Europe, Middle East and Africa Technical Support:

Phone: 00421 33 790 2910

For additional information, please contact your local Sales Representative

X-ON Electronics

Largest Supplier of Electrical and Electronic Components

Click to view similar products for [MOSFET](#) category:

Click to view products by [ON Semiconductor](#) manufacturer:

Other Similar products are found below :

[614233C](#) [648584F](#) [IRFD120](#) [JANTX2N5237](#) [FCA20N60_F109](#) [FDZ595PZ](#) [2SK2545\(Q,T\)](#) [405094E](#) [423220D](#) [TPCC8103,L1Q\(CM](#)
[MIC4420CM-TR](#) [VN1206L](#) [SBVS138LT1G](#) [614234A](#) [715780A](#) [NTNS3166NZT5G](#) [SSM6J414TU,LF\(T](#) [751625C](#) [BUK954R8-60E](#)
[NTE6400](#) [SQJ402EP-T1-GE3](#) [2SK2614\(Te16L1,Q\)](#) [2N7002KW-FAI](#) [DMN1017UCP3-7](#) [EFC2J004NUZTDG](#) [ECH8691-TL-W](#)
[FCAB21350L1](#) [P85W28HP2F-7071](#) [DMN1053UCP4-7](#) [NTE221](#) [NTE222](#) [NTE2384](#) [NTE2903](#) [NTE2941](#) [NTE2945](#) [NTE2946](#) [NTE2960](#)
[NTE2967](#) [NTE2969](#) [NTE2976](#) [NTE455](#) [NTE6400A](#) [NTE2910](#) [NTE2916](#) [NTE2956](#) [NTE2911](#) [DMN2080UCB4-7](#) [TK10A80W,S4X\(S](#)
[SSM6P69NU,LF](#) [DMP22D4UFO-7B](#)