

Ignition Gate Drive IC

FAD1110-F085



SOIC8
CASE 751EB

Description

The FAD1110-F085 is designed to directly drive an ignition IGBT and control the current and spark event of the coil. The coil current is controlled via the input pin. When the differential input is driven high, the output of the FAD1110-F085 is enabled to turn on the IGBT and start charging the coil.

An input spike filter suppresses differential input signals of less than 13 μ s in duration. A Max Dwell timer is included in the FAD1110-F085 which will turn off the IGBT if the input stays active for longer than the programmed time. This time interval can be modified through an external capacitor. When the Max Dwell timer is exceeded, the FAD1110-F085 will enter a Hard-Shut-Down mode (HSD) and turn off the IGBT immediately. The FAD1110-F085 will also limit the collector current of the IGBT to $I_{C(lim)}$ during charging. This again is done through the sense resistor in the emitter leg of the Ignition IGBT developing a signal input to the V_{SENSE} pin of the FAD1110-F085.

Features

- Differential Input for Ground Shift Disturbances Suppression
- Signal Line Input Buffer
- Input Spike Filter
- Operation from Ignition or Battery Line
- Ground Shift Tolerance – 2 V to 3 V
- Programmable Maximum Dwell Time
- Control IGBT Current Limiting through V_{SENSE} Pin
- Hard Shutdown Following Max Dwell Time Out
- This is a Pb-Free Device

Applications

The FAD1110-F085 is an advanced Ignition IGBT control IC available in a SO8 package or die sales. This full featured Smart Ignition IGBT Driver is particularly advantageous in “switch on coil” applications where size and system performance of the ignition driver are important.

MARKING DIAGRAM

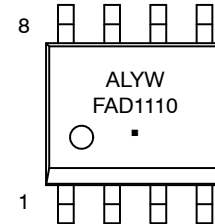

FAD1110	= Specific Device Code
AL	= Assembly Lot Code
Y	= Year
W	= Work Week
▪	= Pb-Free Package

ORDERING INFORMATION

See detailed ordering and shipping information on page 2 of this data sheet.

FAD1110-F085

ORDERING INFORMATION

Part Number	Operating Temperature Range	Package	Shipping [†]
FAD1110-F085	-40°C to 150°C	8-SOIC	2500 units / Tape & Reel

†For information on tape and reel specifications, including part orientation and tape sizes, please refer to our Tape and Reel Packaging Specification Brochure, BRD8011/D.

Recommended External Components

TYPICAL EXTERNAL COMPONENTS

Component	Description	Vendor	Parameter	Typ.	Unit
R _{BAT}	Limits transient currents during load dump		R	200 to 300	Ω
C _{BAT}	Battery or Ignition voltage filtering		C	0.47	μF
C _{BAT1}	Battery noise transients		C	10	nF
C _{INC}	Noise immunity		C	10	nF
C _{IND}	Differential mode Noise immunity		C	1	nF
R _{SENSE}	Sense the collector current		R	20	mΩ
R _{INH}	Input Res High		R	1	kΩ
R _{INL}	Input Res Low		R	1	kΩ
R _{IN}	Adjust input impedance		R		Ω

Typical Application

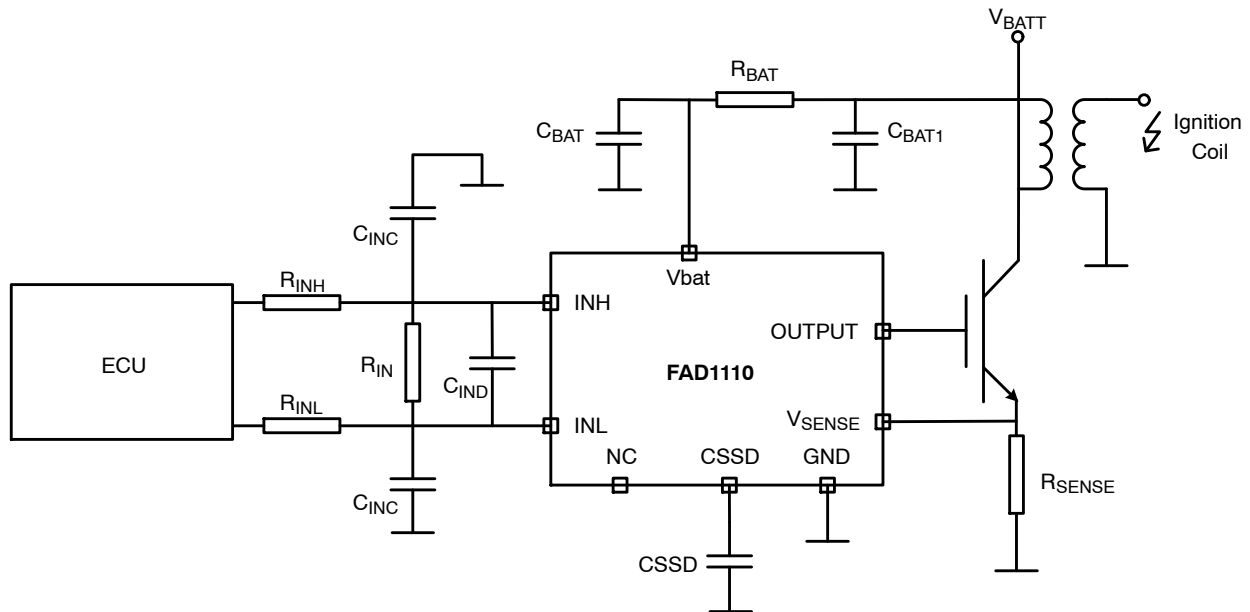

Figure 1. Typical Application

Block Diagram

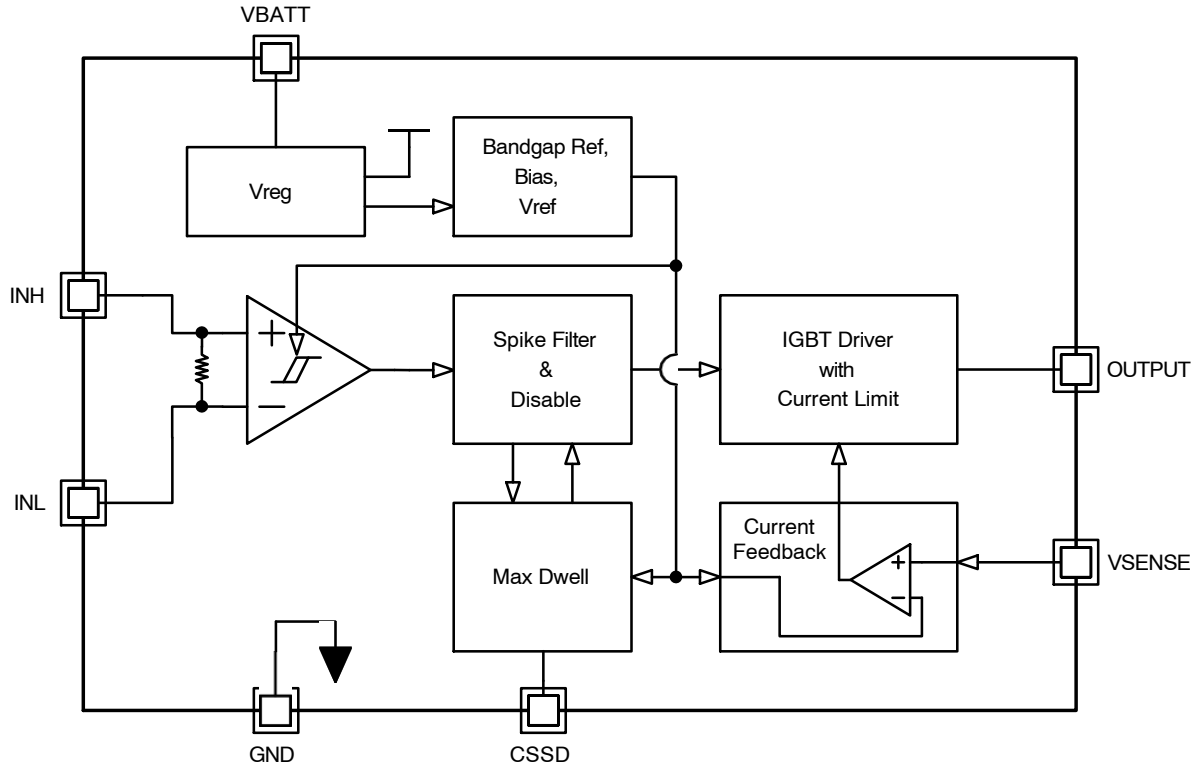

Figure 2. Block Diagram

FAD1110-F085

Package Outline

The FAD1110-F085 is assembled in an 8 lead SOIC Package.

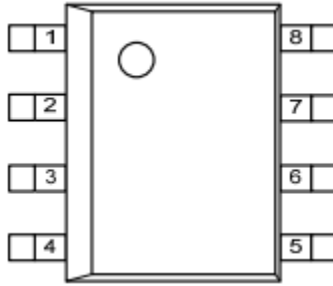

Figure 3. Pin Assignment (Top View)

PIN DESCRIPTION

Name	Type	Description
Pin1	GND	Ground Reference of the Control IC
Pin2	INL	Input ground signal
Pin3	INH	Positive input signal referenced to INL
Pin4	CSSD	Adjust maximum dwell time (to external capacitor)
Pin5	NC	
Pin6	Output	Gate Drive to the IGBT
Pin7	V _{SENSE}	Sense Input used for Ilim function
Pin8	V _{BAT}	Supply voltage

ABSOLUTE MAXIMUM RATINGS (-40°C to 150°C unless otherwise stated)

Symbol	Parameter	Min.	Max.	Unit
V _{BAT}	Voltage at V _{BAT} pin (excl. EMC transients)	-0.3	28	V
V _{INH}	Voltage at Input pin High	-5	18	V
V _{INL}	Voltage at Input pin Low	-5	18	V
V _{CSSD}	Voltage at C _{SSD}	-0.3	3.6	V
V _{OUTPUT}	Voltage at Gate Output	-0.3	6.5	V
V _{SENSE}	Voltage on V _{SENSE} pin	0	400	mV
T _J , T _{STG}	Operating and Storage Temperature Range	-40	150	°C
P _{MAX}	Maximum power dissipation (continuous) at T _C = 25°C		0.625	W
R _{θJC}	Thermal Resistance – Junction-to-Case (typical)		200	°C/W
V _{ESD} (pin to pin incl. V _{INH} and V _{INL})	Electrostatic Discharge Voltage (Human Body Model) according to MIL STD 883D, method 3015.7 and EOS/ESD Assn. standard S5.1 – 1993		2	kV

Stresses exceeding those listed in the Maximum Ratings table may damage the device. If any of these limits are exceeded, device functionality should not be assumed, damage may occur and reliability may be affected.

FAD1110-F085

RECOMMENDED OPERATING CONDITIONS (Reference Load Characteristics) (Note 1)

Symbol	Characteristic	Min.	Typ.	Max.	Units
I_{Ctyp}	Collector (Coil) Operating Current		12		A
L_P	Coil Primary Inductance		1.5		mH
R_P	Coil Primary Resistance (25°C)		0.4		Ω
R_{LOAD}	Load Resistance (for delay time measurements)		2		Ω

Functional operation above the stresses listed in the Recommended Operating Ranges is not implied. Extended exposure to stresses beyond the Recommended Operating Ranges limits may affect device reliability.

1. **onsemi** does not recommend exceeding them or designing to Absolute Maximum Ratings. (-40°C to 150°C unless otherwise stated)

ELECTRICAL CHARACTERISTICS

Symbol	Parameter	Conditions	Min.	Typ.	Max.	Unit
--------	-----------	------------	------	------	------	------

POWER SUPPLY CONDITIONS $V_{BAT} = 6$ to 28 V ; $T_J = -40^\circ\text{C}$ to 150°C (unless otherwise specified)

V_{BAT1}	Operating voltage	Coil switching function	4		28	V
V_{BAT2}	Operating voltage	All functions	6		28	V
I_{BAT}	Supply current	$T_J = 150^\circ\text{C}$, $V_{BAT} = 28$ V, Input = 5 V			4	mA
V_{CLAMP}	$V_{BATTERY}$ clamp	$I_{BATT} = 10$ mA	33		40	V

SENSE PIN CONDITIONS $V_{BAT} = 6$ to 28 V ; $T_J = -40^\circ\text{C}$ to 150 °C (unless otherwise specified)

V_{LIMIT}	Sense Voltage at current limit		200	220	240	mV
T_{SPIKE}	Input spike filter	Delay on rising and falling edge of Input		13		μs
T_{D1}	Turn on delay time	(Time from Input = 4.0 V to $V_{OUT} = 4.0$ V)		17		μs
T_{D2}	Turn off delay time	(Time from Input = 0.5 V to $V_{C-GND} = 1.0$ V)		17		μs

INPUT CONTROL CONDITIONS $V_{BAT} = 6$ to 28 V ; $T_J = -40^\circ\text{C}$ to + 150°C (unless otherwise specified)

V_{INLD}	Differential Input low voltage	INL = GND	1.3	1.7	2.1	V
V_{INHd}	Differential Input high voltage	INL = GND	1.7	2.2	2.7	V
V_{INHys}	Input voltage hysteresis		0.25	0.5	0.75	V
I_{IN}	Input current	$V_{BAT} = 0$ V, INL = GND		$0.10 \times V_{INH}$		mA
I_{IN}	Input current	$6 \text{ V} < V_{BAT} < 20 \text{ V}$, INL = GND		$0.10 \times V_{INH}$		mA
V_{CM}	Common mode voltage	Between V_{INH} and V_{INL} reference to GND	-2		3	V
V_{INHGF}	Floating INH voltage	($6 \text{ V} < V_S < 20 \text{ V}_{INH}$ and INL floating) refer to GND @ $T = 25^\circ\text{C}$		0.5		V
V_{INLGF}	Floating INL voltage	($6 \text{ V} < V_S < 20 \text{ V}_{INH}$ and INL floating) refer to GND @ $T = 25^\circ\text{C}$		0.5		V

GATE OUTPUT VOLTAGE MAX $V_{BAT} = 6$ to 28 V ; $T_J = -40^\circ\text{C}$ to 150°C (unless otherwise specified)

V_{GMAX}	Vgate max	16 K Ω pulldown resistor	4.5	5.4	6	V
V_{GLOW}	Vgate low	($0 \text{ mA} < I_{GATE} < 0.4 \text{ mA}$ @ $T = 25^\circ\text{C}$)	0.0		0.4	V

DIAGNOSTIC FUNCTIONS AND PROTECTION $V_{BAT} = 6$ to 28 V ; $T_J = -40^\circ\text{C}$ to 150°C (unless otherwise specified)

$CSSD_{MIN}$	Minimum dwell time capacitor			5		nF
TD_{MAX}	Maximum dwell time	($CSSD = 50$ nF)	65	100	135	ms
I_{CSSD1}	CSSD Pin current for TD_{MAX}		0.75	1.0	1.25	μA

Product parametric performance is indicated in the Electrical Characteristics for the listed test conditions, unless otherwise noted. Product performance may not be indicated by the Electrical Characteristics if operated under different conditions.

TYPICAL PERFORMANCE CHARACTERISTICS

Input and Spike Filter

When the differential input signal voltage between INH and INL pins reaches $V_{INH,D}$, the IGBT will be switched on charging the coil. When this differential input voltage goes below V_{INLD} , the coil current through the IGBT will be turned off. Positive and negative spikes of less than T_{SPIKE} duration at the input line will be filtered out and will not turn on/off the IGBT.

Maximum Dwell Time and Hard-Shutdown (HSD)

When the IGBT is turned on, a delay timer, dependent on the value of the external CSSD capacitor (see Figure 5), is started. If a valid falling edge has not been received after the time T_{DMAX} , the IGBT will be turned off immediately as shown in Figure 4.

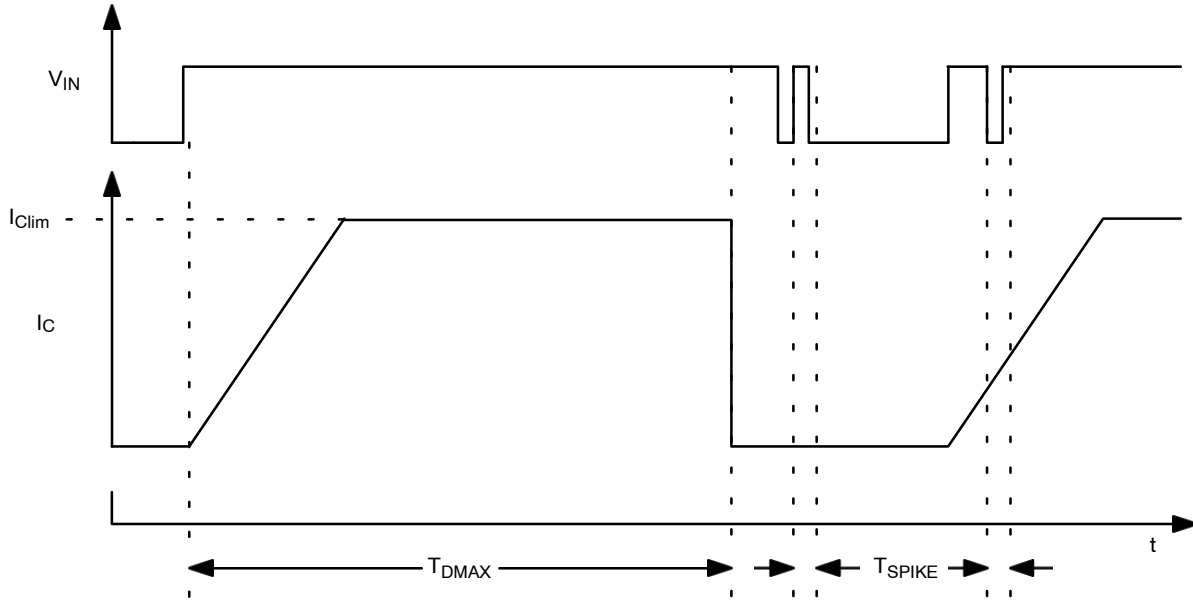

Figure 4. Dwell Time and Hard-Shut-Down

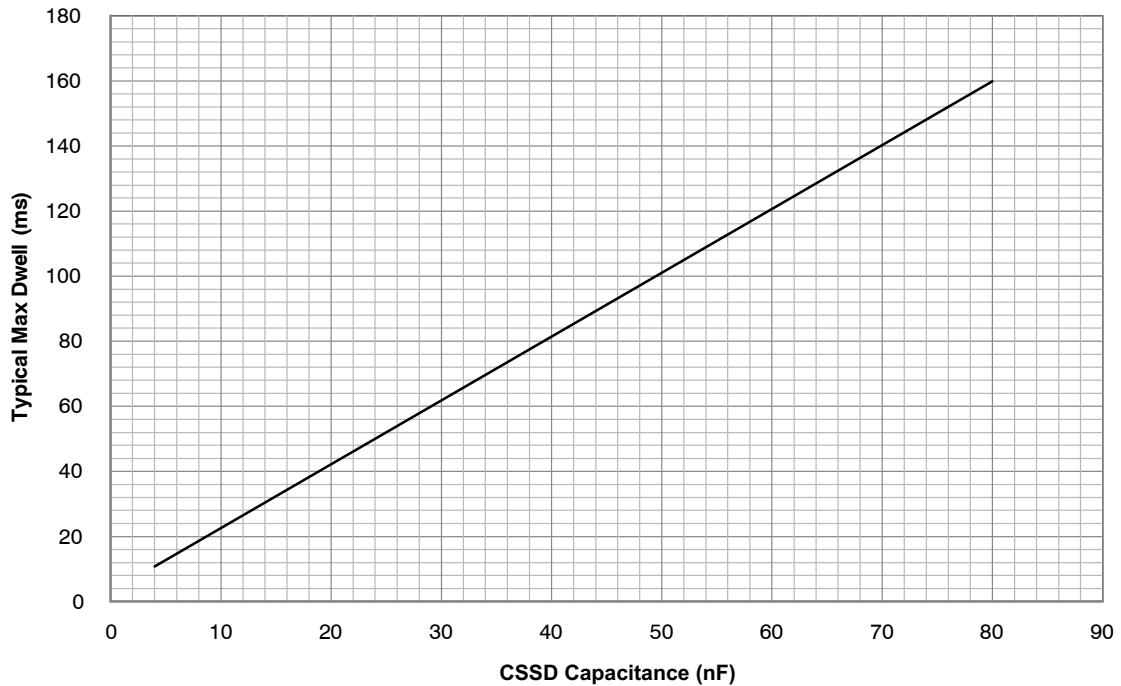
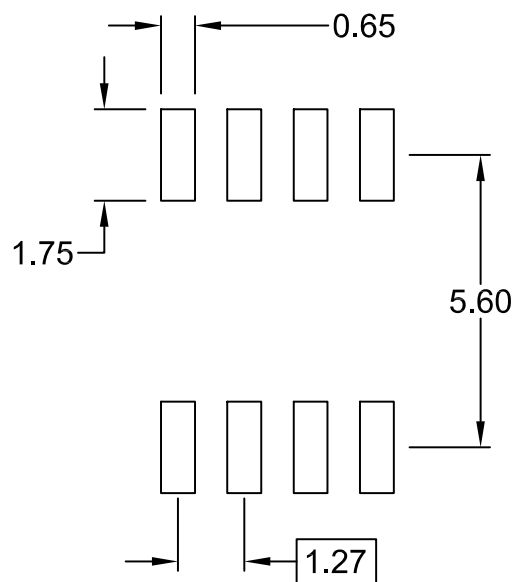
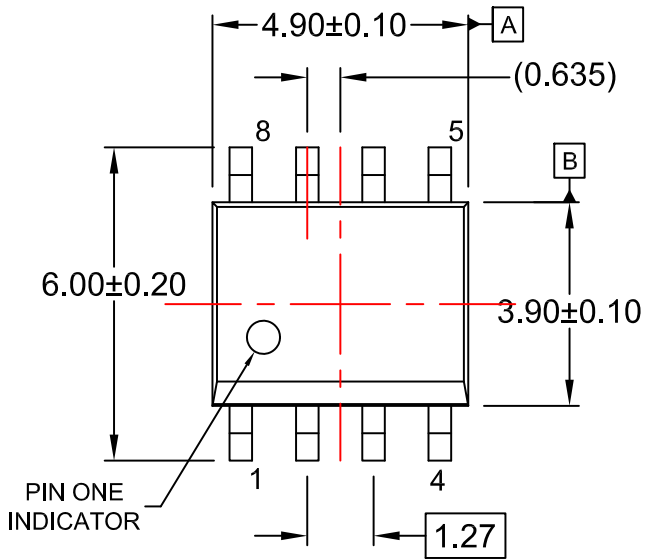

Figure 5. T_{DMAX} as Function of External CSSD Capacitor

FAD1110-F085

PACKAGE DIMENSIONS

SOIC8
CASE 751EB
ISSUE A



\varnothing	0.25(M)	C	B	A
---------------	---------	---	---	---

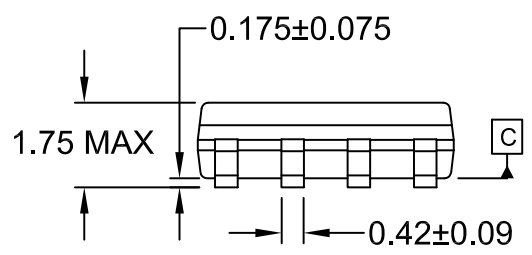

$\frac{1}{2}$	0.10
---------------	------

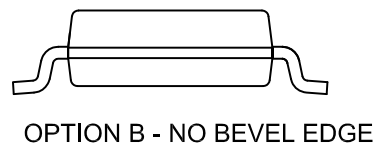
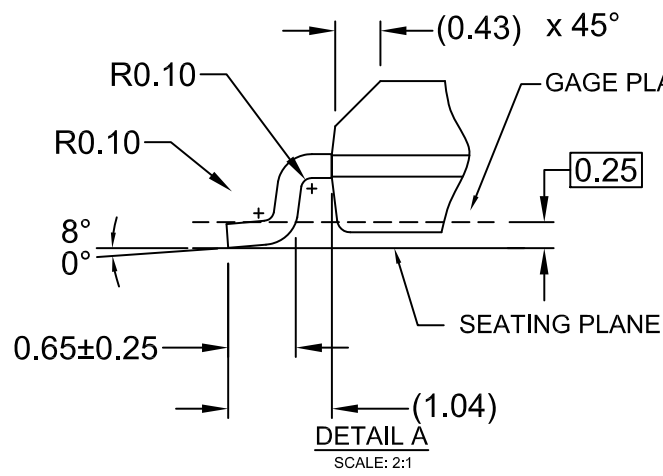
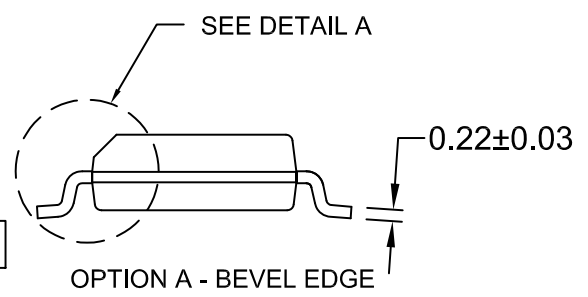

- NOTES:
- A) THIS PACKAGE CONFORMS TO JEDEC MS-012, VARIATION AA.
 - B) ALL DIMENSIONS ARE IN MILLIMETERS.
 - C) DIMENSIONS DO NOT INCLUDE MOLD FLASH OR BURRS.
 - D) LANDPATTERN STANDARD: SOIC127P600X175-8M

onsemi, **Onsemi**, and other names, marks, and brands are registered and/or common law trademarks of Semiconductor Components Industries, LLC dba "**onsemi**" or its affiliates and/or subsidiaries in the United States and/or other countries. **onsemi** owns the rights to a number of patents, trademarks, copyrights, trade secrets, and other intellectual property. A listing of **onsemi**'s product/patent coverage may be accessed at www.onsemi.com/site/pdf/Patent-Marking.pdf. **onsemi** reserves the right to make changes at any time to any products or information herein, without notice. The information herein is provided "as-is" and **onsemi** makes no warranty, representation or guarantee regarding the accuracy of the information, product features, availability, functionality, or suitability of its products for any particular purpose, nor does **onsemi** assume any liability arising out of the application or use of any product or circuit, and specifically disclaims any and all liability, including without limitation special, consequential or incidental damages. Buyer is responsible for its products and applications using **onsemi** products, including compliance with all laws, regulations and safety requirements or standards, regardless of any support or applications information provided by **onsemi**. "Typical" parameters which may be provided in **onsemi** data sheets and/or specifications can and do vary in different applications and actual performance may vary over time. All operating parameters, including "Typicals" must be validated for each customer application by customer's technical experts. **onsemi** does not convey any license under any of its intellectual property rights nor the rights of others. **onsemi** products are not designed, intended, or authorized for use as a critical component in life support systems or any FDA Class 3 medical devices or medical devices with a same or similar classification in a foreign jurisdiction or any devices intended for implantation in the human body. Should Buyer purchase or use **onsemi** products for any such unintended or unauthorized application, Buyer shall indemnify and hold **onsemi** and its officers, employees, subsidiaries, affiliates, and distributors harmless against all claims, costs, damages, and expenses, and reasonable attorney fees arising out of, directly or indirectly, any claim of personal injury or death associated with such unintended or unauthorized use, even if such claim alleges that **onsemi** was negligent regarding the design or manufacture of the part. **onsemi** is an Equal Opportunity/Affirmative Action Employer. This literature is subject to all applicable copyright laws and is not for resale in any manner.

ADDITIONAL INFORMATION

TECHNICAL PUBLICATIONS:

Technical Library: www.onsemi.com/design/resources/technical-documentation
onsemi Website: www.onsemi.com

ONLINE SUPPORT: www.onsemi.com/support

For additional information, please contact your local Sales Representative at www.onsemi.com/support/sales

X-ON Electronics

Largest Supplier of Electrical and Electronic Components

Click to view similar products for [Gate Drivers](#) category:

Click to view products by [ON Semiconductor](#) manufacturer:

Other Similar products are found below :

[56956](#) [57.404.7355.5](#) [LT4936](#) [57.904.0755.0](#) [0131700000](#) [LTP70N06](#) [LVP640](#) [5J0-1000LG-SIL](#) [LY2-US-AC240](#) [LY3-UA-DC24](#) [LZNQ2-US-DC12](#) [LZP40N10](#) [60100564](#) [60249-1-CUT-TAPE](#) [0134220000](#) [6035](#) [60713816](#) [61161-90](#) [6131-204-23149P](#) [6131-205-17149P](#) [6131-209-15149P](#) [6131-218-17149P](#) [6131-220-21149P](#) [6131-260-2358P](#) [6131-265-11149P](#) [CS1HCPU63](#) [6150-5001](#) [CSB4](#) [CSK-38-60006](#) [CSK-38-60008](#) [621A](#) [622-4053LF](#) [6273](#) [M40N08MA-H](#) [M55155/29XH06](#) [64-807](#) [65-1930-6](#) [CV500ISB02](#) [M83723/88Y1407N](#) [CWD012-2](#) [CWD03-3](#) [CX3225SB16934D0PPSC2](#) [CX5032GB10000D0PPS02](#) [687-772NF1](#) [70.140.1653](#) [70.200.0653.0](#) [703001B01F060](#) [70-3601](#) [706006D02F0601](#) [706210](#)