



Is Now Part of



ON Semiconductor®

To learn more about ON Semiconductor, please visit our website at
www.onsemi.com

Please note: As part of the Fairchild Semiconductor integration, some of the Fairchild orderable part numbers will need to change in order to meet ON Semiconductor's system requirements. Since the ON Semiconductor product management systems do not have the ability to manage part nomenclature that utilizes an underscore (_), the underscore (_) in the Fairchild part numbers will be changed to a dash (-). This document may contain device numbers with an underscore (_). Please check the ON Semiconductor website to verify the updated device numbers. The most current and up-to-date ordering information can be found at www.onsemi.com. Please email any questions regarding the system integration to Fairchild_questions@onsemi.com.

ON Semiconductor and the ON Semiconductor logo are trademarks of Semiconductor Components Industries, LLC dba ON Semiconductor or its subsidiaries in the United States and/or other countries. ON Semiconductor owns the rights to a number of patents, trademarks, copyrights, trade secrets, and other intellectual property. A listing of ON Semiconductor's product/patent coverage may be accessed at www.onsemi.com/site/pdf/Patent-Marking.pdf. ON Semiconductor reserves the right to make changes without further notice to any products herein. ON Semiconductor makes no warranty, representation or guarantee regarding the suitability of its products for any particular purpose, nor does ON Semiconductor assume any liability arising out of the application or use of any product or circuit, and specifically disclaims any and all liability, including without limitation special, consequential or incidental damages. Buyer is responsible for its products and applications using ON Semiconductor products, including compliance with all laws, regulations and safety requirements or standards, regardless of any support or applications information provided by ON Semiconductor. "Typical" parameters which may be provided in ON Semiconductor data sheets and/or specifications can and do vary in different applications and actual performance may vary over time. All operating parameters, including "Typicals" must be validated for each customer application by customer's technical experts. ON Semiconductor does not convey any license under its patent rights nor the rights of others. ON Semiconductor products are not designed, intended, or authorized for use as a critical component in life support systems or any FDA Class 3 medical devices or medical devices with a same or similar classification in a foreign jurisdiction or any devices intended for implantation in the human body. Should Buyer purchase or use ON Semiconductor products for any such unintended or unauthorized application, Buyer shall indemnify and hold ON Semiconductor and its officers, employees, subsidiaries, affiliates, and distributors harmless against all claims, costs, damages, and expenses, and reasonable attorney fees arising out of, directly or indirectly, any claim of personal injury or death associated with such unintended or unauthorized use, even if such claim alleges that ON Semiconductor was negligent regarding the design or manufacture of the part. ON Semiconductor is an Equal Opportunity/Affirmative Action Employer. This literature is subject to all applicable copyright laws and is not for resale in any manner.

FAN6292BMX/FAN6292MX

Compact Secondary-Side Synchronous Rectifier Control with USB Type-C Control

FAN6292BMX/FAN6292MX are highly integrated, secondary-side power adaptor controllers compatible with Type-C control. Internally adopted synchronous rectifier control helps for less BOM counts as well as easy design.

FAN6292BMX/FAN6292MX are also a source only USB Type-C controllers which are optimized for mobile chargers and power adapters. It supports standard 3 A VBUS current level. N-Channel MOSFET is compatible as a load switch, and helps to reduce BOM cost.

FAN6292BMX/FAN6292MX incorporate adaptive output under-voltage protection to improve system reliability.

Features

- Type-C Control for Standard 3 A VBUS Current
- N-Channel MOSFET Control as a Type-C Load Switch
- Internal Synchronous Rectifier Control Circuit
- Protections for Safe Operation; Output Under-Voltage-Protection

Typical Applications

- Battery Chargers for Smart Phones, Feature Phones, and Tablet PCs
- AC-DC Adapters for Portable Devices that Require CV/CC Control



ON Semiconductor[®]

www.onsemi.com

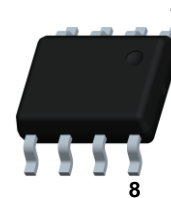

TSSOP-8

MARKING DIAGRAM

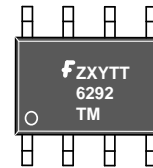

1st Line:

F: Corporate Logo
Z: Assembly Plant Code
X: Year Code
Y: Week Code
TT: Die Run Code

2nd Line:

6292 : IC Part Name for FAN6292MX
6292B: IC Part Name for FAN6292BMX

3rd Line:

T: Package Type (M=SOIC)
M: Manufacture Flow Code

PIN CONNECTIONS

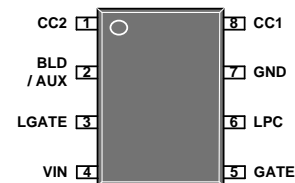

(TOP View)

ORDERING INFORMATION

See detailed ordering and shipping information in the package dimensions section on page 13 of this data sheet.

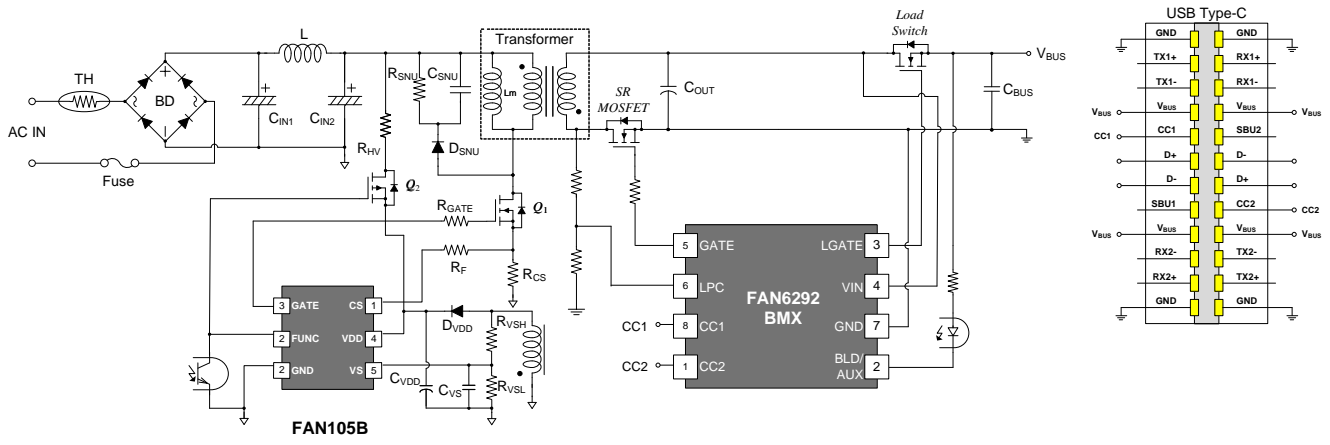

Figure 1 FAN6292BMX Typical Application Schematic

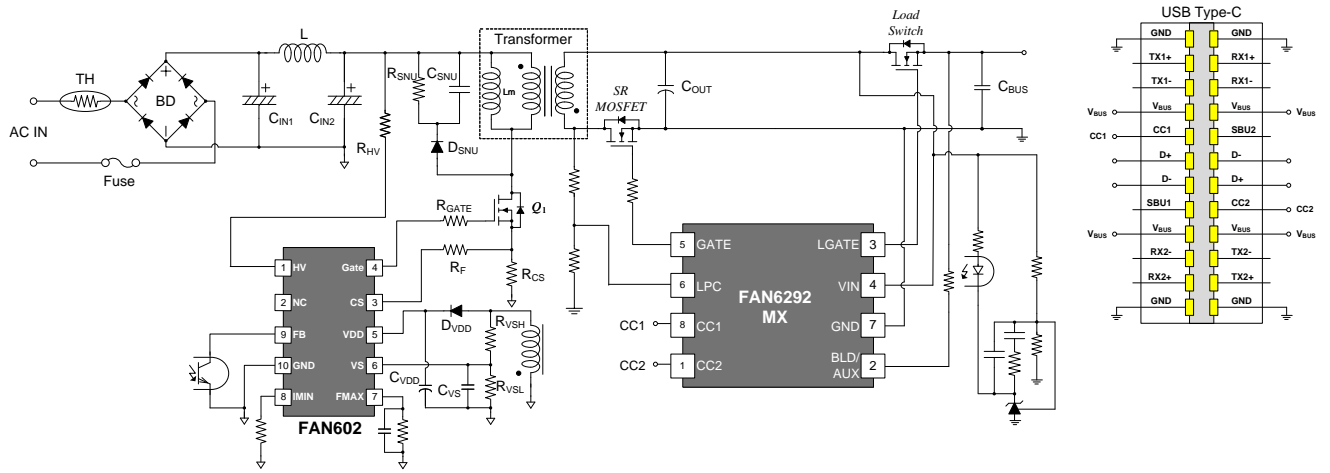
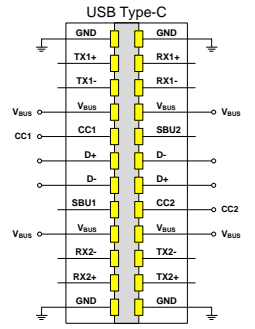
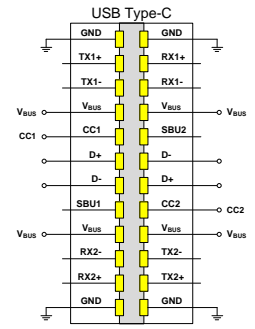

Figure 2 FAN6292MX Typical Application Schematic



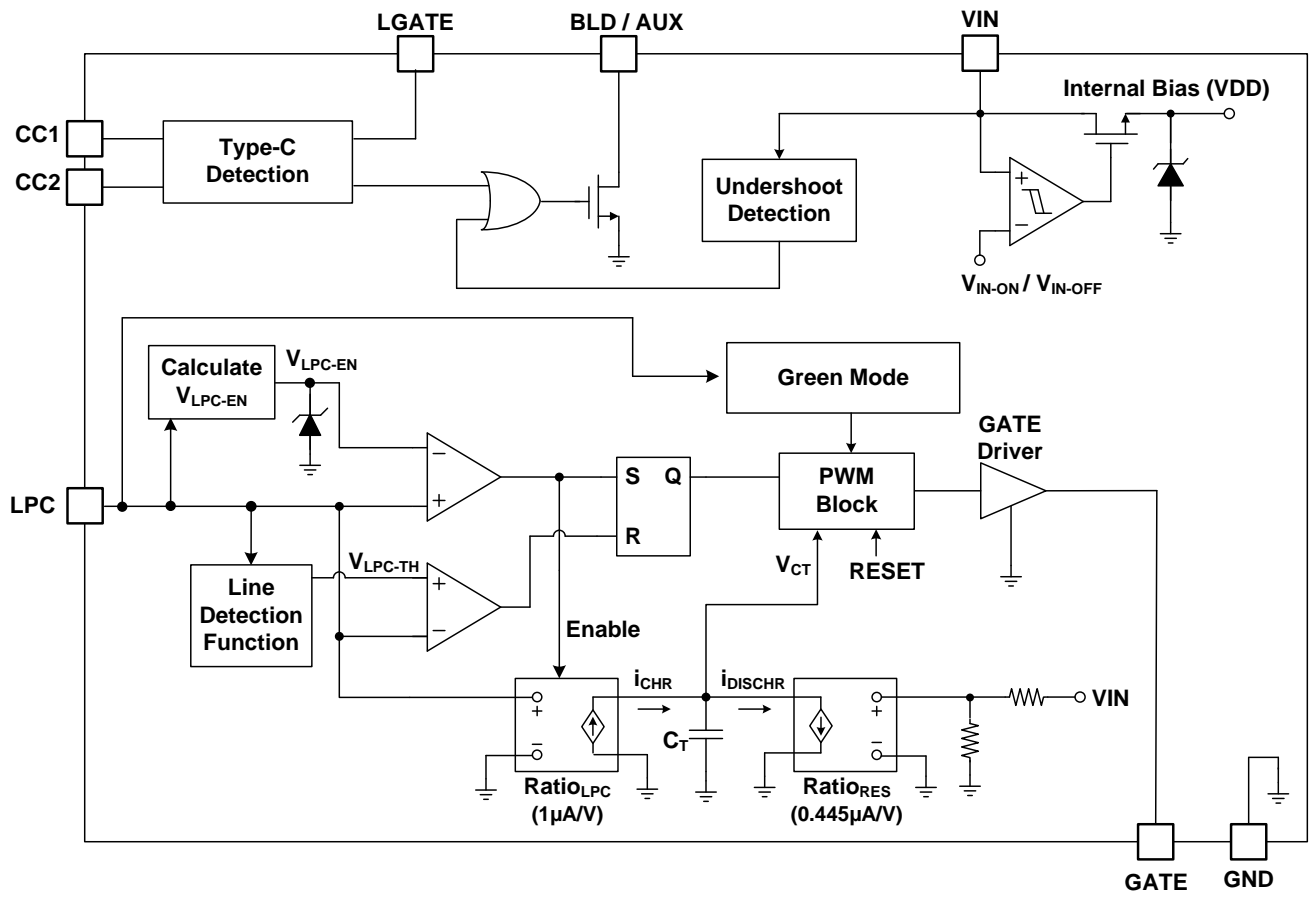

Figure 3 FAN6292BMX/FAN6292MX Function Block Diagram

PIN FUNCTION DESCRIPTION

Pin No.	Pin Name	Description
1	CC2	Configuration Channel 2. This pin is used to detect connections of Type-C cables and connectors. It is tied to the USB Type-C CC2.
2	BLD / AUX	Bleeder and AUX function. Discharging path of output capacitor when UFP detachment is acknowledged. In addition, information is delivered to primary to enhance output performance.
3	LGATE	Load Switch Gate. This pin is tied to the gate of the load switch
4	VIN	Input Voltage. This pin is tied to the output of the adaptor to monitor its output voltage and supply internal bias. IC operating current, and MOSFET gate drive current are supplied through this pin.
5	GATE	Gate Drive Output. Totem-pole output to drive the external SR MOSFET.
6	LPC	SR MOSFET Drain Voltage Detection. This pin is used to detect the voltage on the secondary winding during the on time period of the primary MOSFET.
7	GND	Ground.
8	CC1	Configuration Channel 1. This pin is used to detect connections of Type-C cables and connectors. It is tied to the USB Type-C CC1.

MAXIMUM RATINGS (Note 1,2,3)

Rating	Symbol	Value	Unit
VIN Pin Input Voltage	V _{IN}	20	V
BLD/AUX Pin Input Voltage	V _{BLD/AUX}	20	V
LGATE Pin Input Voltage	V _{LGATE}	20	V
CC1 Pin Input Voltage	V _{CC1}	-0.3 to 6.0	V
CC2 Pin Input Voltage	V _{CC2}	-0.3 to 6.0	V
LPC pin input voltage	V _{LPC}	-0.3 to 6.5	V
GATE pin input voltage	V _{GATE}	-0.3 to 6.0	V
Power Dissipation (T _A =25°C)	P _D	850	mW
Operating Junction Temperature	T _J	-40 to 150	°C
Storage Temperature Range	T _{STG}	-40 to 150	°C
Lead Temperature, (Soldering, 10 Seconds)	T _L	260	°C
Human Body Model, ANSI/ESDA/JEDEC JS-001-2012 (Note 4)	ESD _{HBM}	4	kV
Charged Device Model, JESD22-C101 (Note 4)	ESD _{CDM}	1.75	kV

1. Stresses exceeding those listed in the Maximum Ratings table may damage the device. If any of these limits are exceeded, device functionality should not be assumed, damage may occur and reliability may be affected.
2. All voltage values, except differential voltages, are given with respect to the GND pin.
3. Stresses beyond those listed under Absolute Maximum Ratings may cause permanent damage to the device.
4. Meets JEDEC standards JS-001-2012 and JESD 22-C101.

THERMAL CHARACTERISTICS (Note 5)

Rating	Symbol	Value	Unit
Thermal Characteristics, Thermal Resistance, Junction-to-Air Thermal Reference, Junction-to-Top	R _{BJA} R _{WJT}	153 22	°C/W

5. T_A=25°C unless otherwise specified.

RECOMMENDED OPERATING RANGES (Note 6)

Rating	Symbol	Min	Max	Unit
VIN Pin Input Voltage	V _{IN}	0	6	V
BLD/AUX Pin Input Voltage	V _{BLD/AUX}	0	6	V
LGATE Pin Input Voltage	V _{LGATE}	0	10	V
CC1 Pin Input Voltage	V _{CC1}	0	5.8	V
CC2 Pin Input Voltage	V _{CC2}	0	5.8	V
LPC pin input voltage	V _{LPC}	0	5	V
GATE pin input voltage	V _{GATE}	0	5.5	V

6. Functional operation above the stresses listed in the Recommended Operating Ranges is not implied. Extended exposure to stresses beyond the Recommended Operating Ranges limits may affect device reliability.

ELECTRICAL CHARACTERISTICS

$V_{IN}=5\text{ V}$, $LPC=1.5\text{ V}$, $LPC\text{ width}=2\ \mu\text{s}$ at $T_j=-40\sim 125\text{ }^\circ\text{C}$, $F_{LPC}=100\text{ kHz}$, unless otherwise specified.

Parameter	Test Conditions	Symbol	Min	Typ	Max	Unit
-----------	-----------------	--------	-----	-----	-----	------

VIN Section

Continuous Operating Voltage ⁽⁷⁾		V_{IN-OP}			6	V
Operating Supply Current	$V_{IN}=5\text{ V}$	$I_{IN-OP-5V}$		8		mA
Green Mode Operating Supply Current	$V_{IN}=5\text{ V}$, with SR gate $F = 400\text{Hz}$ CC1/CC2 open circuit	$I_{IN-OP-Green}$	0.5	0.9	1.3	mA

Internal Bias Section

Turn-On Threshold Voltage	V_{IN} increases	V_{IN-ON}	3.0	3.2	3.4	V
Turn-Off Threshold Voltage	V_{IN} decreases	V_{IN-OFF}	2.75	2.85	2.95	V

Green Mode Section (FAN6292BMX)

Green Mode Enable Debounce Time	Non-switching time, when LPC falling	$t_{Green-EN-Debounce}$	54	64	74	μs
Number of switching to enter green mode	When switching period > $T_{Green-EN-Debounce}$	$N_{Green-EN-Debounce}$		1		Cycle
Green Mode Disable Debounce Time	Enable after enter green mode, Non-switching time, when LPC falling	$t_{Green-DIS-Debounce}$	54	64	74	μs

Green Mode Section (FAN6292MX)

Green Mode Enable Debounce Time	Non-switching time, when when LPC falling	$t_{Green-EN-Debounce}$	0.4	0.5	0.6	ms
Green Mode Disable Debounce Time	Enable after enter green mode, Non-switching time, when LPC falling	$t_{Green-DIS-Debounce}$	0.2	0.3	0.4	ms
Number of consecutive switching to leave green mode	Independently enable with $T_{Green-DIS-Debounce}$, when LPC falling	$N_{Green-DIS-Debounce}$		256		Cycles

Bleeder Section

BLD Pin Sink Current through when bleeding ⁽⁷⁾	$V_{BLD}=5\text{ V}$	$I_{BLD-Sink}$	90			mA
Maximum Discharging Time when bleeding		$t_{BLD-MAX}$	275	320	365	ms

AUX Section (FAN6292BMX)

Output undershoot detection threshold voltage		V_{IN-AUX}	4.7	4.8	4.9	V
Internal debounce time to enable I_{AUX} ⁽⁷⁾	RC filter type	$T_{AUX-Debounce}$			5	μs
BLD/AUX pin pull-down time		T_{AUX-ON}	44	64	84	μs
BLD/AUX pin pull down current with $V_{AUX}=5\text{V}$	$V_{BLD}=5\text{ V}$, $R_{BLD}=0\ \Omega$	I_{AUX}	3.3		15	mA

ELECTRICAL CHARACTERISTICS

$V_{IN}=5\text{ V}$, $LPC=1.5\text{ V}$, $LPC\text{ width}=2\text{ }\mu\text{s}$ at $T_J=-40\sim 125\text{ }^\circ\text{C}$, $F_{LPC}=100\text{ kHz}$, unless otherwise specified.

Parameter	Test Conditions	Symbol	Min	Typ	Max	Unit
-----------	-----------------	--------	-----	-----	-----	------

Type-C Section

Source current on CC1 pin	$V_{IN}=5\text{ V}$, $V_{CC2}=0\text{ V}$	I_{P-CC1}	304	330	356	μA
Source current on CC2 pin	$V_{IN}=5\text{ V}$, $V_{CC1}=0\text{ V}$	I_{P-CC2}	304	330	356	μA
Input impedance on CC1 pin		$Z_{OPEN-CC1}$	126			$\text{k}\Omega$
Input impedance on CC2 pin		$Z_{OPEN-CC2}$	126			$\text{k}\Omega$
Ra impedance detection threshold on CC1 pin	$V_{IN}=5\text{ V}$, $V_{CC2}=0\text{ V}$, Decreasing V_{CC1}	V_{RA-CC1}	0.75	0.80	0.85	V
Ra impedance detection threshold on CC2 pin	$V_{IN}=5\text{ V}$, $V_{CC1}=0\text{ V}$, Decreasing V_{CC2}	V_{RA-CC2}	0.75	0.80	0.85	V
Rd impedance detection threshold on CC1 pin	$V_{IN}=5\text{ V}$, $V_{CC2}=0\text{ V}$, Increasing V_{CC1}	V_{RD-CC1}	2.45	2.60	2.75	V
Rd impedance detection threshold on CC2 pin	$V_{IN}=5\text{ V}$, $V_{CC1}=0\text{ V}$, Increasing V_{CC2}	V_{RD-CC2}	2.45	2.60	2.75	V
UFP attachment debounce time	$V_{IN}=5\text{ V}$, $V_{CC2}=0\text{ V}$, Increasing V_{CC1}	$t_{CC-Attach-debounce}$	100	150	200	ms
UFP detachment debounce time	$V_{IN}=5\text{ V}$, $V_{CC2}=0\text{ V}$, Decreasing V_{CC1}	$t_{CC-Detach-debounce}$	10	15	20	ms
After $t_{CC-attach-debounce}$ until $V_{BUS}=5\text{ V}^{(7)}$	$V_{IN}=5\text{ V}$, $V_{CC2}=0\text{ V}$, Increasing V_{CC1}	$t_{VBUS-ON}$			275	ms
After detaching UFP until $V_{BUS}=0\text{ V}^{(7)}$	$V_{IN}=5\text{ V}$, $V_{CC2}=0\text{ V}$, Decreasing V_{CC1}	$t_{VBUS-OFF}$			650	ms
Gate high voltage	$V_{IN}=5\text{ V}$	V_{NGATE}	8		10	V

Output Driver Section

Output Voltage Low	$V_{IN}=5\text{ V}$, $I_{GATE}=100\text{ mA}$	V_{OL}		0.16	0.25	V
Output Voltage High	$V_{IN}=5\text{ V}$	V_{OH}	4.5			V
Rising Time ⁽⁷⁾	$V_{IN}=5\text{ V}$, $C_L=3300\text{ pF}$, $GATE=1\text{ V} \sim 4\text{ V}$	t_R		20	35	ns
Falling Time ⁽⁷⁾	$V_{IN}=5\text{ V}$, $C_L=3300\text{ pF}$, $GATE=4\text{ V} \sim 1\text{ V}$	t_F		9		ns
Propagation Delay to OUT High (LPC trigger)	$V_{IN}=5\text{ V}$, $GATE=1\text{ V}$	$t_{PD-HIGH-LPC}$		44	80	ns
Propagation Delay to OUT Low (LPC trigger) ⁽⁷⁾	$V_{IN}=5\text{ V}$, $GATE=4\text{ V}$	$t_{PD-LOW-LPC}$		30		ns
Gate inhibit Time ⁽⁷⁾		$t_{INHIBIT}$		1.4		μs
Gate start-up disable time	For FAN602 (FAN6292MX)	$t_{SR-startup-dis}$		60		ms
Gate start-up disable time	For FAN105B (FAN6292BMX)	$t_{SR-startup-dis}$	1.5	2	2.5	ms

ELECTRICAL CHARACTERISTICS

V_{IN}=5 V, LPC=1.5 V, LPC width=2 μs at T_J= -40~125 °C, F_{LPC}=100 kHz, unless otherwise specified.

Parameter	Test Conditions	Symbol	Min	Typ	Max	Unit
Internal RES section						
Internal RES ratio	V _{IN} =5 V, Turn-ratio=15~17	K _{RES}	0.196	0.200	0.204	V/V
VIN Dropping Protection Ratio with Two Cycle	LPC width=5 μs V _{IN} =5 V to 3.5 V	K _{VIN-DROP}	70		90	%
Debounce time for disable SR when VIN dropping protection		t _{SR-OFF}	3.5	5.5	7.5	ms
Debounce time for noise immunity on VIN ⁽⁷⁾		t _{VIN-Debounce}	1	2	3	μs

LPC Section

Linear Operation Range of LPC Pin Voltage ⁽⁷⁾	V _{IN-OFF} < V _{IN} ≤ 5V	V _{LPC}	0.4		V _{IN} - 1	V
LPC Sink Current	V _{LPC} =1V	I _{LPC-SINK}		100		nA
SR Enabled Threshold Voltage @High Line		V _{LPC-HIGH-H}	1.418	1.500	1.583	V
Threshold Voltage on LPC Rising Edge @High Line ⁽⁷⁾	V _{LPC-HIGH-H} *0.875 = V _{LPC-TH-H}	V _{LPC-TH-H}	1.205	1.313	1.424	V
SR Enabled Threshold Voltage @ Low Line	V _{LPC-HIGH-L-5V} = V _{LPC-TH-L-5V} / 0.875	V _{LPC-HIGH-L-5V}	0.703	0.743	0.783	V
Threshold Voltage on LPC Rising Edge @ Low Line ⁽⁷⁾	Spec.=0.4+0.05*V _{IN} V _{IN} = 5V	V _{LPC-TH-L-5V}	0.63	0.650	0.67	V
Falling Edge Threshold Voltage to trigger SR ⁽⁷⁾		V _{LPC-TH-TRIG}		70		mV
Low to High Line Threshold Voltage on LPC pin	V _{IN} = 5V, Spec.=(0.8+0.03*V _{IN})*2	V _{LINE-H-5V}	1.81	1.90	1.99	V
High to Low Line Threshold Voltage on LPC pin	V _{IN} = 5V, Spec.=(0.75+0.03*V _{IN})*2	V _{LINE-L-5V}	1.72	1.80	1.88	V
Line Change Threshold Hysteresis	V _{LINE-HYS-5V} = V _{LINE-H-5V} - V _{LINE-L-5V}	V _{LINE-HYS-5V}		0.1		V
Higher Clamp Voltage		V _{LPC-CLAMP-H}	5.4	6.2	7.0	V
LPC Threshold Voltage to Disable SR Gate Switching	V _{IN} = 5V LPC=3V↑	V _{LPC-DIS}	V _{IN} - 0.6			V
Enable V _{LPC-DIS}	Increasing V _{IN}	V _{EN-LPC-DIS}	4.25	4.4	4.45	V
Disable V _{LPC-DIS}	Decreasing V _{IN}	V _{DIS-LPC-DIS}	4.1	4.2	4.3	V
Line Change Debounce from Low Line to High Line ⁽⁷⁾	Counts for LPC falling < V _{LPC-TH-L-5V}	t _{LPC-LH-debounce}		7		cycles
Line Change Debounce from High Line to Low Line ⁽⁷⁾		t _{LPC-HL-debounce}		15		μs

ELECTRICAL CHARACTERISTICS

V_{IN}=5 V, V_{LPC}=1.5 V, V_{LPC} width=2 μs at T_J= -40~125 °C, F_{LPC}=100 kHz, unless otherwise specified

Parameter	Test Conditions	Symbol	Min	Typ	Max	Unit
Internal Timing Section						
LPC Transfer Ratio to I _{LPC} ⁽⁷⁾		Ratio _{LPC}		1		μA/V
V _{RES} Transfer Ratio to I _{RES} ⁽⁷⁾		Ratio _{RES}		0.445		μA/V
Ratio between V _{LPC} & V _{RES}	V _{IN} =5V, F _{LPC} =50 kHz, K _{RES} =0.20	Ratio _{LPC-RES}	3.15	3.37	3.59	
Minimum LPC Time to Enable the SR Gate @ High Line	V _{LPC} =3V	t _{LPC-EN-H}	80	180	280	ns
Minimum LPC Time to Enable the SR Gate @ Low Line	V _{LPC} =1.5V	t _{LPC-EN-L}	500	600	700	ns
Minimum Gate Width	FAN6292BMX	t _{MIN}	1.9	2.2	2.5	μs
Max SR On Time ⁽⁷⁾		t _{ON-MAX}	20			μs
t _{on-SR(n+1)} - t _{on-SR(n)} < t _{gate-limit}		t _{gate-limit}	350	500	650	ns
Maximum Gate Limit On-time ⁽⁷⁾		t _{gate-limit-max}		5		μs
Forced internal CT reset time ⁽⁷⁾		t _{CT-RESET}		10		ns

Reverse Current Mode Section

Reverse current mode entry debounce time	V _{IN} =5 V, V _{LPC} =0 V	T _{reverse-debounce}	350	500	650	ms
Operating current during reverse current mode	V _{IN} =5 V, V _{LPC} =0 V	I _{OP.reverse}			1.7	mA
Source current on CC1 pin during reverse current mode ⁽⁷⁾	V _{IN} =5 V, V _{LPC} =0 V	I _{P-CC1.reverse}			10	μA
Source current on CC2 pin during reverse current mode ⁽⁷⁾	V _{IN} =5 V, V _{LPC} =0 V	I _{P-CC2.reverse}			10	μA
AUX pin current during reverse current mode ⁽⁷⁾	V _{IN} =5 V, V _{LPC} =0 V	I _{BLD.reverse}			10	uA

7. Guaranteed by Design.

8. Guaranteed at -5° ~ 85°C.

T Y P I C A L C H A R A C T E R I S T I C S

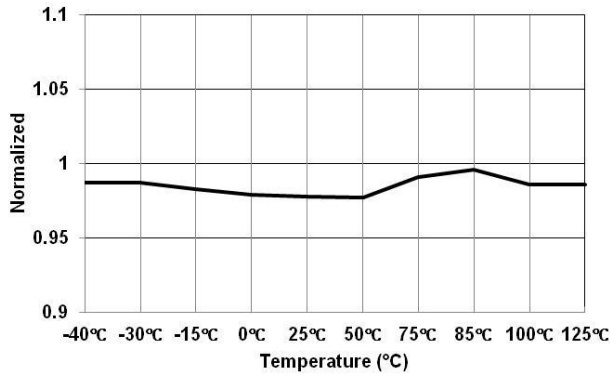

Figure 4 Turn-On Threshold Voltage (V_{IN-ON}) vs. Temperature

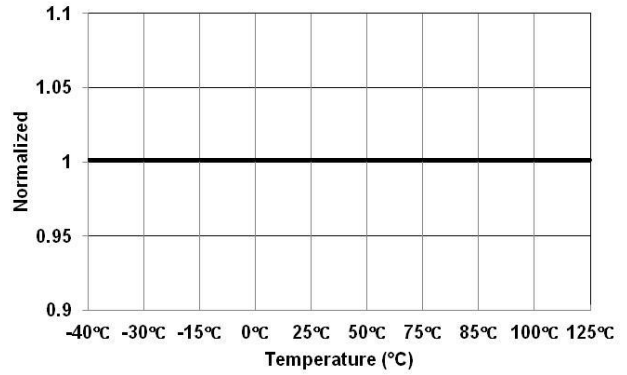

Figure 5 Turn-Off Threshold Voltage (V_{IN-OFF}) vs. Temperature

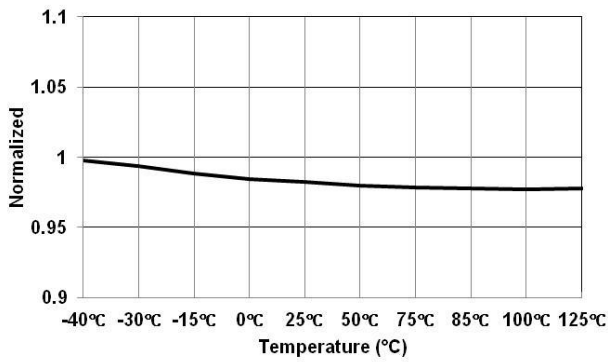

Figure 6 Minimum LPC Time to Enable the SR Gate @ Low-Line ($t_{LPC-EN-L}$) vs. Temperature

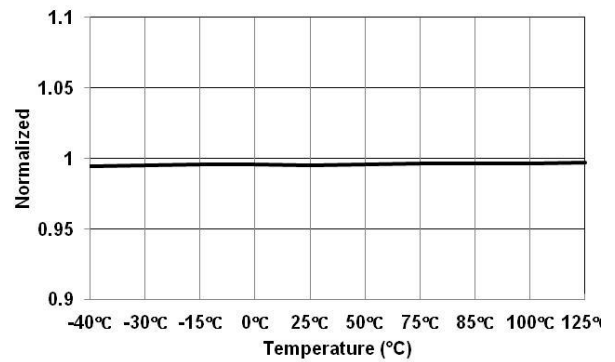

Figure 7 VIN Under-Voltage-Protection Enable (V_{IN-AUX}) vs. Temperature

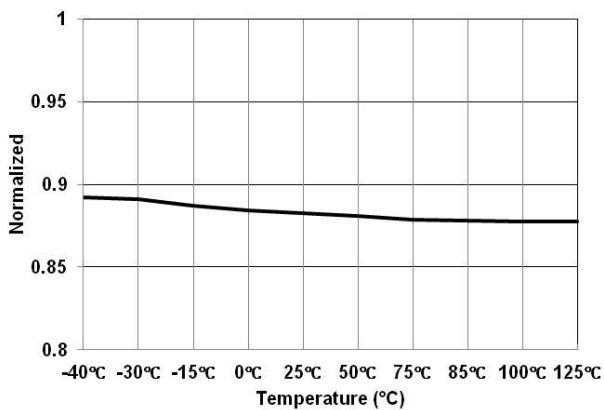

Figure 8 Minimum LPC Time to Enable the SR Gate @ High-Line ($t_{LPC-EN-H}$) vs. Temperature

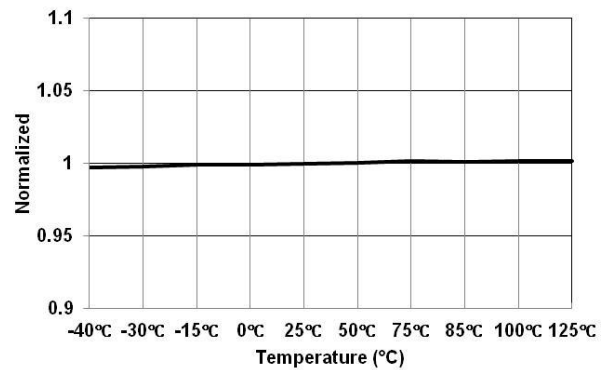

Figure 9 Ratio between V_{LPC} & V_{RES} ($Ratio_{LPC-RES}$) vs. Temperature

T Y P I C A L C H A R A C T E R I S T I C S

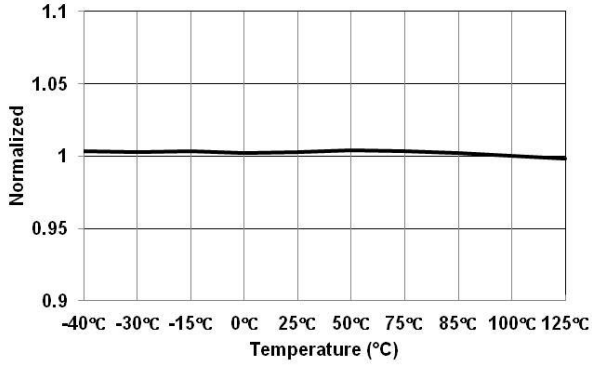

Figure 10 Source Current on CC1 Pin (I_{P-CC1}) vs. Temperature

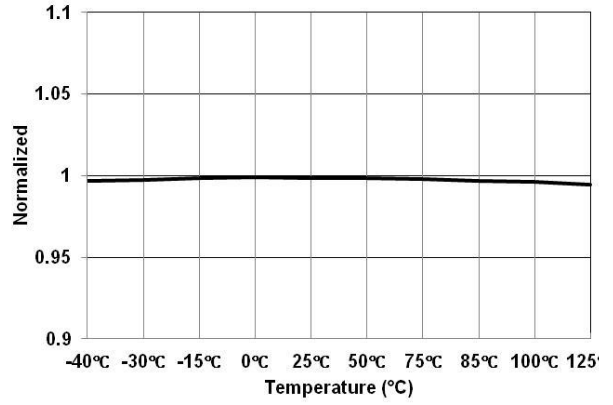

Figure 11 Source Current on CC2 Pin (I_{P-CC2}) vs. Temperature

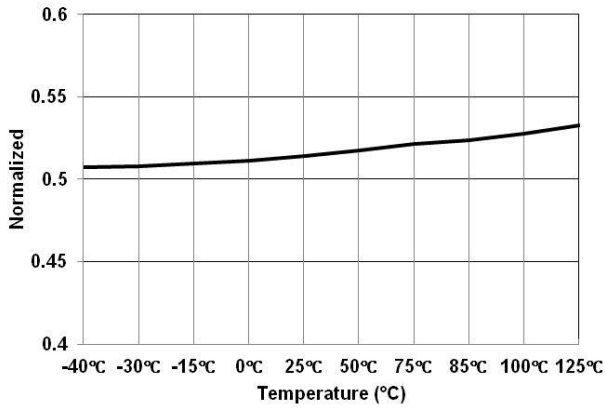

Figure 12 Operating Current during Reverse Current Mode ($I_{OP.reverse}$) vs. Temperature

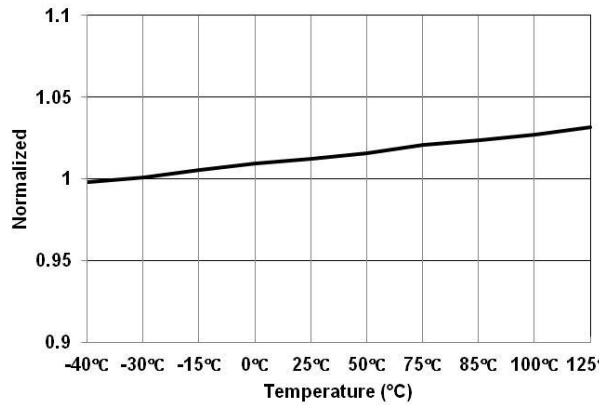

Figure 13 Gate High Voltage (V_{NGATE}) vs. Temperature

APPLICATIONS INFORMATION

N-channel MOSFET for Load Switch

FAN6292BMX/FAN6292MX implement Type-C block to enable or disable an external load switch. Internally adapted charge pump lets it control N-channel MOSFET as a load switch. It helps system be more cost competitive compared to P-channel MOSFET as a load switch. Since the minimum pumped voltage is $V_{BUS}+3\text{ V}$, it is recommended to use N-channel MOSFET supporting lower gate threshold levels.

Detail of Load Switch Control

FAN6292BMX/FAN6292MX support output current higher than 1.5 A. In order to meet Type-C specification, 330 μA is applied on CC1 pin and CC2 pin. When R_d (5.1 $\text{k}\Omega$) is attached on either CC1 or CC2, load switch is turned-on after 150 ms debounce time. As soon as load switch is enabled, BC1.2 counter is enabled. To acknowledge detachment, it needs 15 ms (typ.) debounce time. When load switch is turned-off, bleeder is also enabled at the same time.

Green Mode Operation (for FAN6292BMX)

In order to reduce power consumption at light-load conditions with FAN105B system, FAN6292BMX in green mode will disable LPC internal detection block but SR continuously works at mini on time for FAN105B which is a pure primary side controller to normally regulate output voltage. When V_{LPC} is smaller than $V_{LPC-HIGH-L-5V}$ and maintains duration longer than $t_{Green-EN-Debounce}$, FAN6292MX enters green mode where current can be reduced to 0.9 mA (typ.). It leaves green mode when V_{LPC} is larger than $V_{LPC-HIGH-L-5V}$ and maintains duration shorter than $t_{Green-DIS-Debounce}$.

Green Mode Operation(for FAN6292MX)

In order to reduce power consumption at light-load conditions with FAN602 system, FAN6292MX enters the green mode where some internal blocks are disabled such as Synchronous Rectifier control block. Therefore, the operating current can be largely reduced. It enters Green Mode when V_{LPC} is smaller than $V_{LPC-HIGH-L-5V}$ and maintains duration longer than $t_{Green-EN-Debounce}$. It leaves green mode when V_{LPC} is larger than $V_{LPC-HIGH-L-5V}$ and maintains duration shorter than $t_{Green-DIS-Debounce}$.

Bleeder Function

When the portable device is detached, BUS voltage should be discharged to zero within a short time to meet TypeC specification. FAN6292BMX/ FAN6292MX support bleeding function by turning on S1 for $T_{BLD-max}$ as shown in Figure 14. The amount of bleeding current through BLD/AUX pin can be controlled by the external resistor R_{BLD} shown in (1).

$$I_{BLD-RType} = \frac{V_{O_MAX}}{R_{BLD} + R_{Internal}} \quad (1)$$

VIN-UVP Protection(for FAN6292BMX)

Since pure primary side controller detects and regulates output voltage only when switching, it is not easy maintaining output voltage when load suddenly increases from light load where switching frequency is slow to heavy load. Therefore, as Figure 15, FAN6292BMX automatically detects output voltage. When output undershoot is acknowledged via VIN pin, BLD/AUX pin pull-down current via S2 switch to inform undershoot status to primary controller via a photo-coupler. Since the pull-down current is limited through S2, the current will not affect to the amount of output current.

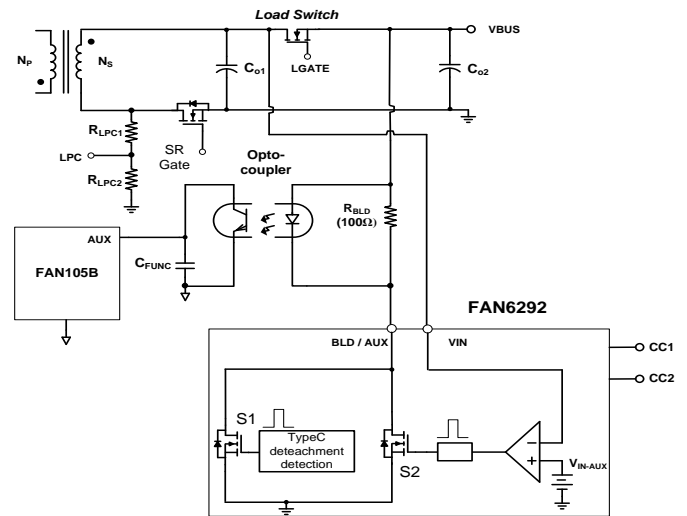

Figure 14 BLD/AUX Function Diagram

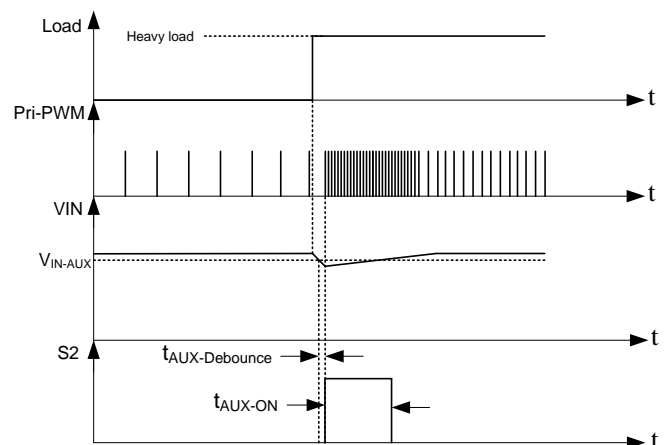
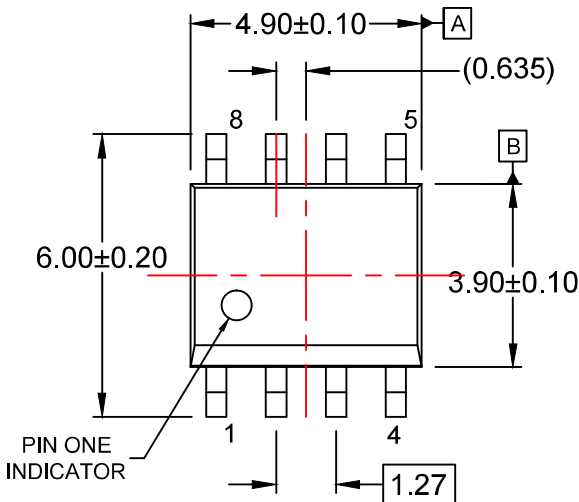

Figure 15 VIN-UVP Protection

ORDERING INFORMATION

Part Number	Operating Temperature Range	Package	Packing Method
FAN6292BMX	-40°C to +125°C	8-Lead, Small Outline Package (SOIC), JEDEC MS-012, .150-Inch Narrow Body	Tape & Reel
FAN6292MX	-40°C to +125°C	8-Lead, Small Outline Package (SOIC), JEDEC MS-012, .150-Inch Narrow Body	Tape & Reel

†For information on tape and reel specifications, including part orientation and tape sizes, please refer to our Tape and Reel Packaging Specifications Brochure, BRD8011/D



⊕ 0.25(M) C B A

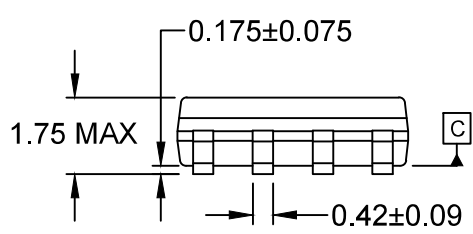
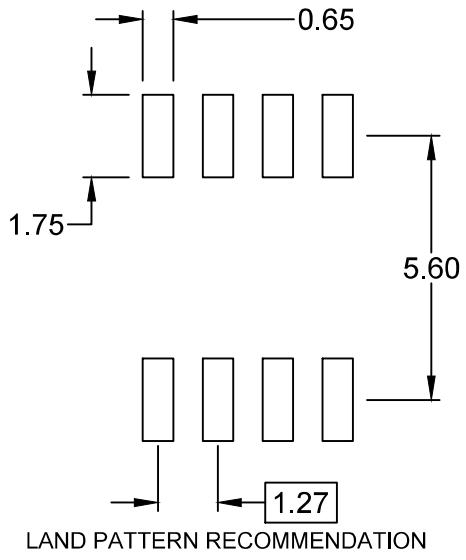

0.10

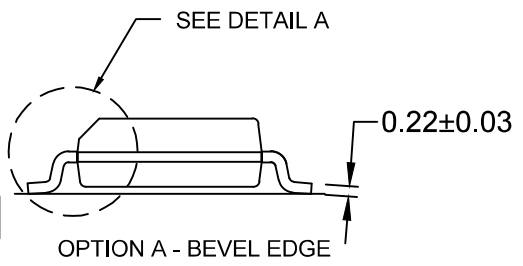

OPTION A - BEVEL EDGE

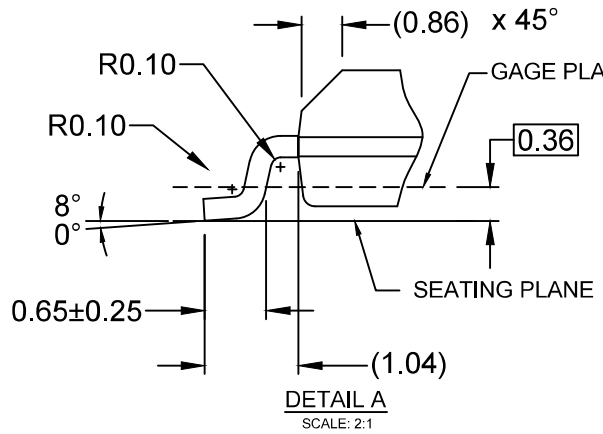

DETAIL A
SCALE: 2:1

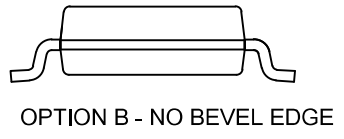

OPTION B - NO BEVEL EDGE

NOTES:

- A) THIS PACKAGE CONFORMS TO JEDEC MS-012, VARIATION AA.
- B) ALL DIMENSIONS ARE IN MILLIMETERS.
- C) DIMENSIONS DO NOT INCLUDE MOLD FLASH OR BURRS.
- D) LANDPATTERN STANDARD: SOIC127P600X175-8M
- E) DRAWING FILENAME: M08Arev16



ON Semiconductor and  are trademarks of Semiconductor Components Industries, LLC dba ON Semiconductor or its subsidiaries in the United States and/or other countries. ON Semiconductor owns the rights to a number of patents, trademarks, copyrights, trade secrets, and other intellectual property. A listing of ON Semiconductor's product/patent coverage may be accessed at www.onsemi.com/site/pdf/Patent-Marking.pdf. ON Semiconductor reserves the right to make changes without further notice to any products herein. ON Semiconductor makes no warranty, representation or guarantee regarding the suitability of its products for any particular purpose, nor does ON Semiconductor assume any liability arising out of the application or use of any product or circuit, and specifically disclaims any and all liability, including without limitation special, consequential or incidental damages. Buyer is responsible for its products and applications using ON Semiconductor products, including compliance with all laws, regulations and safety requirements or standards, regardless of any support or applications information provided by ON Semiconductor. "Typical" parameters which may be provided in ON Semiconductor data sheets and/or specifications can and do vary in different applications and actual performance may vary over time. All operating parameters, including "Typicals" must be validated for each customer application by customer's technical experts. ON Semiconductor does not convey any license under its patent rights nor the rights of others. ON Semiconductor products are not designed, intended, or authorized for use as a critical component in life support systems or any FDA Class 3 medical devices or medical devices with a same or similar classification in a foreign jurisdiction or any devices intended for implantation in the human body. Should Buyer purchase or use ON Semiconductor products for any such unintended or unauthorized application, Buyer shall indemnify and hold ON Semiconductor and its officers, employees, subsidiaries, affiliates, and distributors harmless against all claims, costs, damages, and expenses, and reasonable attorney fees arising out of, directly or indirectly, any claim of personal injury or death associated with such unintended or unauthorized use, even if such claim alleges that ON Semiconductor was negligent regarding the design or manufacture of the part. ON Semiconductor is an Equal Opportunity/Affirmative Action Employer. This literature is subject to all applicable copyright laws and is not for resale in any manner.

PUBLICATION ORDERING INFORMATION

LITERATURE FULFILLMENT:

Literature Distribution Center for ON Semiconductor
19521 E. 32nd Pkwy, Aurora, Colorado 80011 USA
Phone: 303-675-2175 or 800-344-3860 Toll Free USA/Canada
Fax: 303-675-2176 or 800-344-3867 Toll Free USA/Canada
Email: orderlit@onsemi.com

N. American Technical Support: 800-282-9855 Toll Free
USA/Canada
Europe, Middle East and Africa Technical Support:
Phone: 421 33 790 2910
Japan Customer Focus Center
Phone: 81-3-5817-1050

ON Semiconductor Website: www.onsemi.com
Order Literature: <http://www.onsemi.com/orderlit>
For additional information, please contact your local
Sales Representative

X-ON Electronics

Largest Supplier of Electrical and Electronic Components

Click to view similar products for [Power Management Specialised - PMIC category:](#)

Click to view products by [ON Semiconductor manufacturer:](#)

Other Similar products are found below :

[LV5686PVC-XH](#) [FAN7710VN](#) [NCP391FCALT2G](#) [SLG7NT4081VTR](#) [SLG7NT4192VTR](#) [AP4313UKTR-G1](#) [AS3729B-BWLM](#)
[MB39C831QN-G-EFE2](#) [MAX4940MB](#) [LV56841PVD-XH](#) [MAX77686EWE+T](#) [AP4306BUKTR-G1](#) [MIC5164YMM](#) [PT8A3252WE](#)
[NCP392CSFCCT1G](#) [TEA1998TS/1H](#) [PT8A3284WE](#) [PI3VST01ZEEX](#) [PI5USB1458AZAEX](#) [PI5USB1468AZAEX](#) [MCP16502TAC-E/S8B](#)
[MCP16502TAE-E/S8B](#) [MCP16502TAA-E/S8B](#) [MCP16502TAB-E/S8B](#) [TCKE712BNL,RF](#) [ISL91211AIKZT7AR5874](#)
[ISL91211BIKZT7AR5878](#) [MAX17506EVKITBE#](#) [MCP16501TC-E/RMB](#) [ISL91212AIIZ-TR5770](#) [ISL91212BIIZ-TR5775](#) [CPX200D](#) [AX-](#)
[3005D-3](#) [TP-1303](#) [TP-1305](#) [TP-1603](#) [TP-2305](#) [TP-30102](#) [TP-4503N](#) [MIC5167YML-TR](#) [LPTM21-1AFTG237C](#) [MPS-3003L-3](#) [MPS-3005D](#)
[SPD-3606](#) [STLUX383A](#) [TP-60052](#) [ADN8834ACBZ-R7](#) [LM26480SQ-AA/NOPB](#) [LM81BIMTX-3/NOPB](#) [LM81CIMT-3/NOPB](#)