



Is Now Part of



**ON Semiconductor®**

To learn more about ON Semiconductor, please visit our website at  
[www.onsemi.com](http://www.onsemi.com)

Please note: As part of the Fairchild Semiconductor integration, some of the Fairchild orderable part numbers will need to change in order to meet ON Semiconductor's system requirements. Since the ON Semiconductor product management systems do not have the ability to manage part nomenclature that utilizes an underscore (\_), the underscore (\_) in the Fairchild part numbers will be changed to a dash (-). This document may contain device numbers with an underscore (\_). Please check the ON Semiconductor website to verify the updated device numbers. The most current and up-to-date ordering information can be found at [www.onsemi.com](http://www.onsemi.com). Please email any questions regarding the system integration to [Fairchild\\_questions@onsemi.com](mailto:Fairchild_questions@onsemi.com).

ON Semiconductor and the ON Semiconductor logo are trademarks of Semiconductor Components Industries, LLC dba ON Semiconductor or its subsidiaries in the United States and/or other countries. ON Semiconductor owns the rights to a number of patents, trademarks, copyrights, trade secrets, and other intellectual property. A listing of ON Semiconductor's product/patent coverage may be accessed at [www.onsemi.com/site/pdf/Patent-Marking.pdf](http://www.onsemi.com/site/pdf/Patent-Marking.pdf). ON Semiconductor reserves the right to make changes without further notice to any products herein. ON Semiconductor makes no warranty, representation or guarantee regarding the suitability of its products for any particular purpose, nor does ON Semiconductor assume any liability arising out of the application or use of any product or circuit, and specifically disclaims any and all liability, including without limitation special, consequential or incidental damages. Buyer is responsible for its products and applications using ON Semiconductor products, including compliance with all laws, regulations and safety requirements or standards, regardless of any support or applications information provided by ON Semiconductor. "Typical" parameters which may be provided in ON Semiconductor data sheets and/or specifications can and do vary in different applications and actual performance may vary over time. All operating parameters, including "Typicals" must be validated for each customer application by customer's technical experts. ON Semiconductor does not convey any license under its patent rights nor the rights of others. ON Semiconductor products are not designed, intended, or authorized for use as a critical component in life support systems or any FDA Class 3 medical devices or medical devices with a same or similar classification in a foreign jurisdiction or any devices intended for implantation in the human body. Should Buyer purchase or use ON Semiconductor products for any such unintended or unauthorized application, Buyer shall indemnify and hold ON Semiconductor and its officers, employees, subsidiaries, affiliates, and distributors harmless against all claims, costs, damages, and expenses, and reasonable attorney fees arising out of, directly or indirectly, any claim of personal injury or death associated with such unintended or unauthorized use, even if such claim alleges that ON Semiconductor was negligent regarding the design or manufacture of the part. ON Semiconductor is an Equal Opportunity/Affirmative Action Employer. This literature is subject to all applicable copyright laws and is not for resale in any manner.



# FL6632 Primary-Side-Regulated LED Driver with Power Factor Correction

## Features

- Cost-Effective Solution: No Input Bulk Capacitor or Feedback Circuitry
- Power Factor Correction
- Accurate Constant-Current (CC) Control, Independent Online Voltage, Output Voltage, and Magnetizing Inductance Variation
- Linear Frequency Control Improves Efficiency and Simplifies Design
- Open-LED Protection
- Short-LED Protection
- Cycle-by-Cycle Current Limiting
- Over-Temperature Protection with Auto Restart
- Low Startup Current: 20  $\mu$ A
- Low Operating Current: 5 mA
- $V_{DD}$  Under-Voltage Lockout (UVLO)
- Gate Output Maximum Voltage Clamped at 18V
- SOP-8 Package
- Application Voltage Range: 80  $V_{AC}$  ~ 308  $V_{AC}$

## Applications

- LED Lighting System

## Description

This highly integrated PWM controller provides several features to enhance the performance of low-power flyback converters. The proprietary topology enables simplified circuit design for LED lighting applications.

By using single-stage topology with primary-side regulation, a LED lighting board can be implemented with few external components and minimized cost. No input bulk capacitor or feedback circuitry is required. To implement good power factor and low THD, constant on-time control is utilized with an external capacitor connected to the COM1 pin.

Precise constant-current control regulates accurate output current versus changes in input voltage and output voltage. The operating frequency is proportionally adjusted by the output voltage to guarantee DCM operation with higher efficiency and simpler design.

FL6632 provides open-LED, short-LED, and over-temperature protection features. The current limit level is automatically reduced to minimize output current and protect external components in a short-LED condition.

The FL6632 controller is available in an 8-pin Small-Outline Package (SOP).

## Ordering Information

Part Number	Operating Temperature Range	Package	Packing Method
FL6632MX	-40°C to +125°C	8-Lead, Small Outline Integrated Circuit Package (SOIC)	Tape & Reel

### Application Diagram

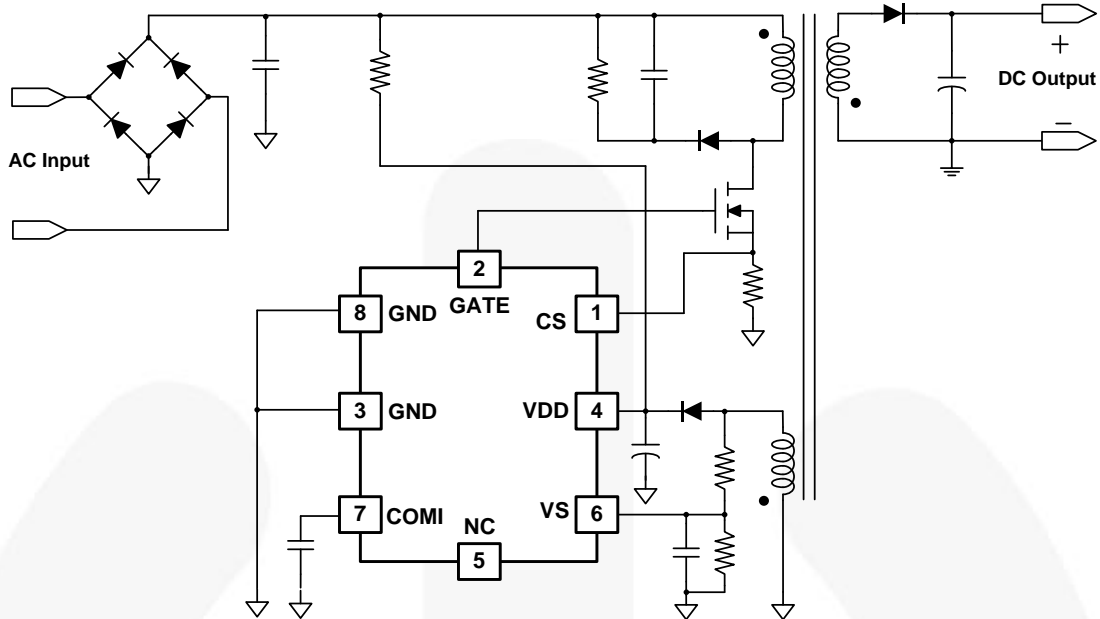

Figure 1. Typical Application

### Block Diagram

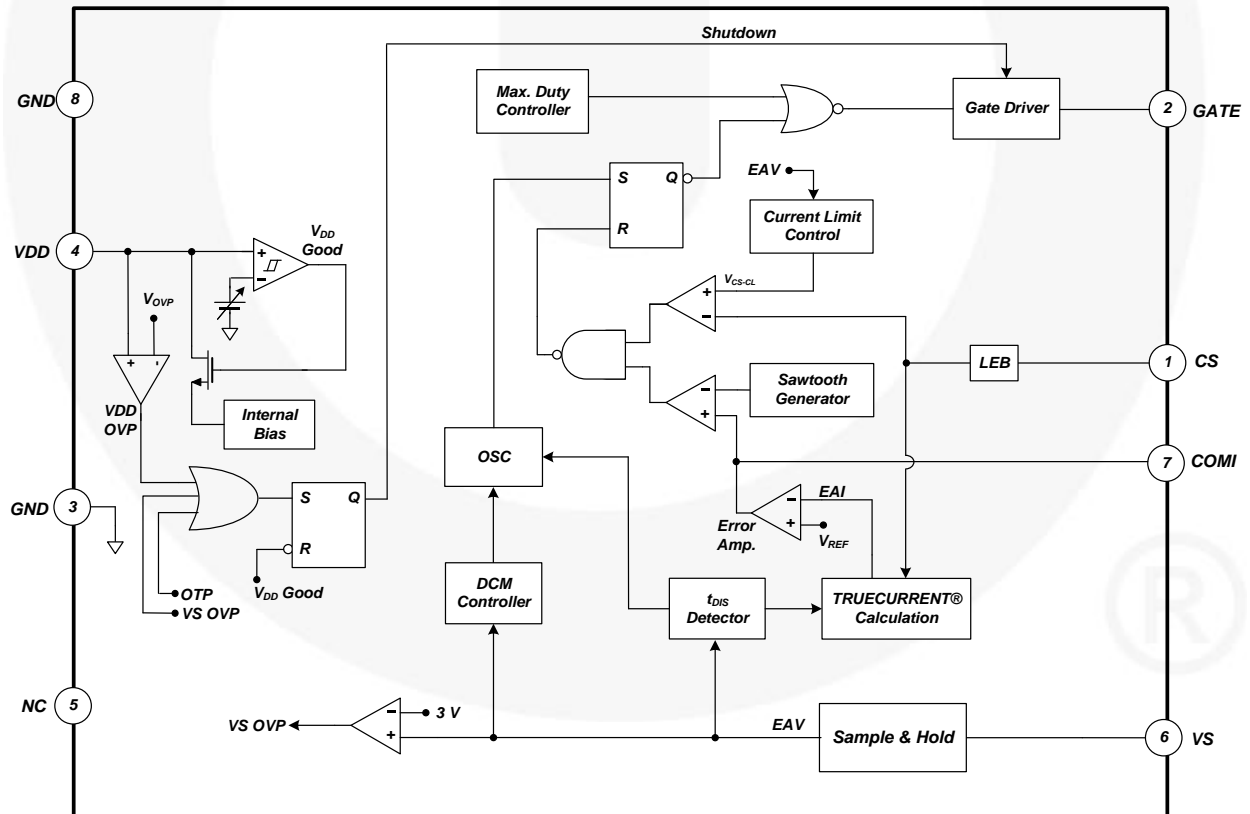
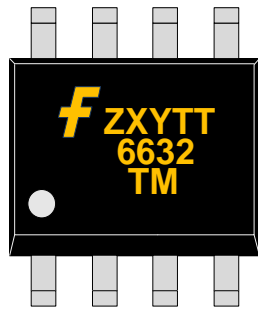

Figure 2. Functional Block Diagram

## Marking Information



F:	Fairchild Logo
Z:	Plant Code
X:	1-Digit Year Code
Y:	1-Digit Week Code
TT:	2-Digit Die Run Code
T:	Package Type (M=SOP)
M:	Manufacture Flow Code

Figure 3. Top Mark

## Pin Configuration

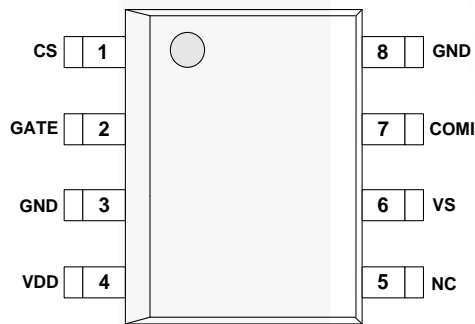

Figure 4. Pin Configuration (Top View)

## Pin Descriptions

Pin #	Name	Description
1	CS	<b>Current Sense.</b> This pin connects a current-sense resistor to detect the MOSFET current for the output-current regulation in constant-current regulation.
2	GATE	<b>PWM Signal Output.</b> This pin uses the internal totem-pole output driver to drive the power MOSFET.
3	GND	Ground
4	VDD	<b>Power Supply.</b> IC operating current and MOSFET driving current are supplied using this pin.
5	NC	No Connect
6	VS	<b>Voltage Sense.</b> This pin detects the output voltage information and discharge time for maximum frequency control and constant current regulation. This pin is connected to an auxiliary winding of the transformer via resistors of the divider.
7	COMI	<b>Constant Current Loop Compensation.</b> This pin is connected to a capacitor between the COMI and GND pin for compensation current loop gain.
8	GND	Ground

## Absolute Maximum Ratings

Stresses exceeding the absolute maximum ratings may damage the device. The device may not function or be operable above the recommended operating conditions and stressing the parts to these levels is not recommended. In addition, extended exposure to stresses above the recommended operating conditions may affect device reliability. The absolute maximum ratings are stress ratings only.

Symbol	Parameter	Min.	Max.	Unit
V <sub>VDD</sub>	DC Supply Voltage <sup>(1,2)</sup>		30	V
V <sub>VS</sub>	VS Pin Voltage	-0.3	7	V
V <sub>CS</sub>	CS Pin Input Voltage	-0.3	7	V
V <sub>COMI</sub>	COMI Pin Input Voltage	-0.3	7	V
V <sub>GATE</sub>	GATE Pin Input Voltage	-0.3	30	V
P <sub>D</sub>	Power Dissipation (T <sub>A</sub> < 50°C)		633	mW
T <sub>J</sub>	Maximum Junction Temperature		150	°C
T <sub>STG</sub>	Storage Temperature Range	-55	150	°C
T <sub>L</sub>	Lead Temperature (Soldering 10s)		260	°C

### Notes:

1. Stresses beyond those listed under Absolute Maximum Ratings may cause permanent damage to the device.
2. All voltage values, except differential voltages, are given with respect to GND pin.

## Thermal Impedance

T<sub>A</sub>=25°C, unless otherwise specified.

Symbol	Parameter	Value	Unit
θ <sub>JA</sub>	Junction-to-Ambient Thermal Impedance	158	°C/W
θ <sub>JC</sub>	Junction-to-Case Thermal Impedance	39	°C/W

### Note:

3. Referenced the JEDEC recommended environment, JESD51-2, and test board, JESD51-3, 1S1P with minimum land pattern.

## ESD Capability

Symbol	Parameter	Value	Unit
ESD	Human Body Model, ANSI/ESDA/JEDEC JS-001-2012	4	kV
	Charged Device Model, JESD22-C101	2	

### Note:

4. Meets JEDEC standards JESD22-A114 and JESD 22-C101.

## Electrical Characteristics

$V_{DD}=15\text{ V}$ ,  $T_J=-40$  to  $+125^\circ\text{C}$ , unless otherwise specified. Currents are defined as positive into the device and negative out of device.

Symbol	Parameter	Conditions	Min.	Typ.	Max.	Unit
<b>VDD SECTION</b>						
$V_{DD-ON}$	Turn-On Threshold Voltage		14.5	16.0	17.5	V
$V_{DD-OFF}$	Turn-Off Threshold Voltage		6.75	7.75	8.75	V
$I_{DD-OP}$	Operating Current	At Maximum Frequency $C_L=1\text{ nF}$	3	4	5	mA
$I_{DD-ST}$	Startup Current	$V_{DD}=V_{DD-ON} - 0.16\text{ V}$		2	20	$\mu\text{A}$
$V_{OVP}$	$V_{DD}$ Over-Voltage-Protection Level		22.0	23.5	25.0	V
<b>GATE SECTION</b>						
$V_{OL}$	Output Voltage Low	$V_{DD}=20\text{ V}$ , $I_{GATE}=-1\text{ mA}$			1.5	V
$V_{OH}$	Output Voltage High	$V_{DD}=10\text{ V}$ , $I_{GATE}=+1\text{ mA}$	5			V
$I_{source}$	Peak Sourcing Current	$V_{DD}=10 \sim 20\text{ V}$		60		mA
$I_{sink}$	Peak Sinking Current	$V_{DD}=10 \sim 20\text{ V}$		180		mA
$t_r$	Rising Time	$C_L=1\text{ nF}$	100	150	200	ns
$t_f$	Falling Time	$C_L=1\text{ nF}$	20	60	100	ns
$V_{CLAMP}$	Output Clamp Voltage		12	15	18	V
<b>Oscillator SECTION</b>						
$f_{MAX-CC}$	Maximum Frequency in CC	$V_{DD}=10\text{ V}$ , $20\text{ V}$	60	65	70	kHz
$f_{MIN-CC}$	Minimum Frequency in CC	$V_{DD}=10\text{ V}$ , $20\text{ V}$	21.0	23.5	26.0	kHz
$t_{ON(MAX)}$	Maximum Turn-On Time		12	14	16	$\mu\text{s}$
<b>CURRENT-ERROR-AMPLIFIER SECTION</b>						
$V_{RV}$	Reference Voltage		2.475	2.500	2.525	V
$V_{CCR}$	EAI Voltage for CC Regulation	$V_{CS}=0.44\text{ V}$	2.38	2.43	2.48	V
$t_{LEB}$	Leading-Edge Blanking Time			300		ns
$t_{MIN}$	Minimum On Time in CC	$V_{COMI}=0\text{ V}$		600		ns
$t_{PD}$	Propagation Delay to GATE		50	100	150	ns
$t_{DIS-BNK}$	$t_{DIS}$ Blanking Time of VS			1.5		$\mu\text{s}$
$I_{VS-BNK}$	VS Current for VS Blanking			-100		$\mu\text{A}$
<b>Current-Error-Amplifier SECTION</b>						
$G_m$	Transconductance			85		$\mu\text{mho}$
$I_{COMI-SINK}$	COMI Sink Current	$V_{EAI}=3\text{ V}$ , $V_{COMI}=5\text{ V}$	25		38	$\mu\text{A}$
$I_{COMI-SOURCE}$	COMI Source Current	$V_{EAI}=2\text{ V}$ , $V_{COMI}=0\text{ V}$	25		38	$\mu\text{A}$
$V_{COMI-HGH}$	COMI High Voltage	$V_{EAI}=2\text{ V}$	4.9			V
$V_{COMI-LOW}$	COMI Low Voltage	$V_{EAI}=3\text{ V}$			0.1	V

**Electrical Characteristics** (Continued)

$V_{DD}=15\text{ V}$ ,  $T_J=-40$  to  $+125^\circ\text{C}$ , unless otherwise specified. Currents are defined as positive into the device and negative out of device.

Symbol	Parameter	Conditions	Min.	Typ.	Max.	Unit
<b>VOLTAGE-SENSE SECTION</b>						
$V_{OCP}$	$V_{CS}$ Threshold Voltage for OCP		0.63	0.70	0.77	V
$V_{LowOCP}$	$V_{CS}$ Threshold Voltage for Low OCP		0.15	0.20	0.25	V
$V_{LowOCP-EN}$	$V_S$ Threshold Voltage to Enable Low OCP Level			0.4		V
$V_{LowOCP-DIS}$	$V_S$ Threshold Voltage to Disable Low OCP Level			0.6		V
$V_{VS-OVP}$	$V_S$ Level for Output Over-Voltage Protection		2.9	3.0	3.1	V
<b>OVER-TEMPERATURE-PROTECTION SECTION</b>						
$T_{OTP}$	Threshold Temperature for OTP <sup>(5)</sup>		140	150	160	$^\circ\text{C}$
$T_{OTP-HYS}$	Restart Junction Temperature Hysteresis			10		$^\circ\text{C}$

**Note:**

5. The Ensured by design. Not tested in production.

## Typical Performance Characteristics

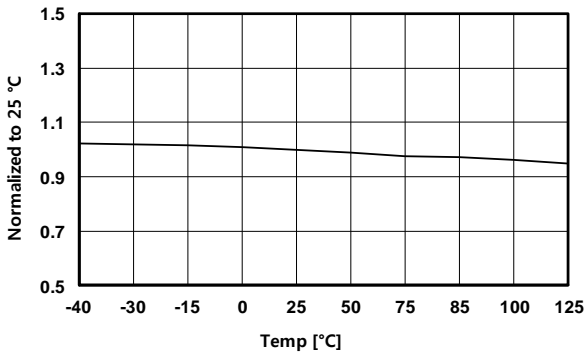

Figure 5. V<sub>DD-ON</sub> vs. Temperature

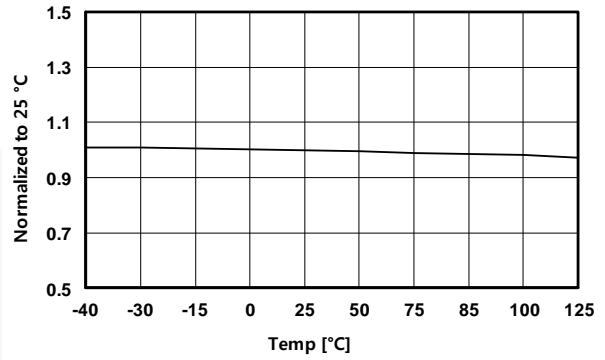

Figure 6. V<sub>DD-OFF</sub> vs. Temperature

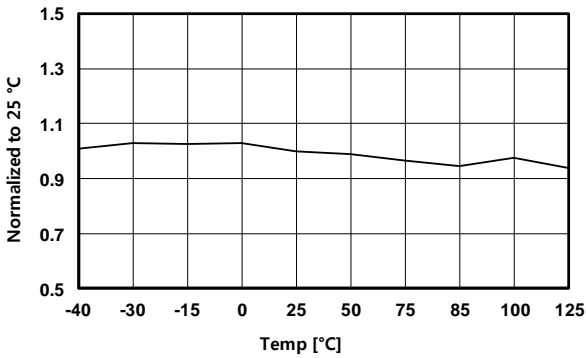

Figure 7. I<sub>DD-OP</sub> vs. Temperature

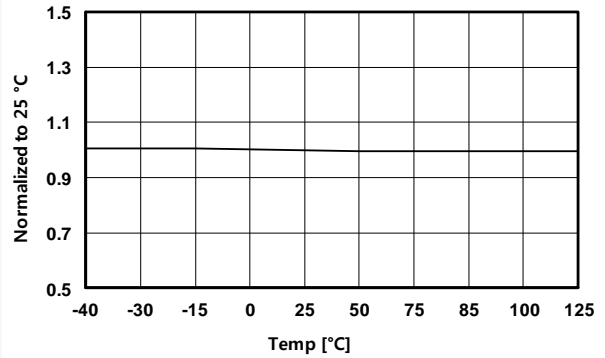

Figure 8. V<sub>OVP</sub> vs. Temperature

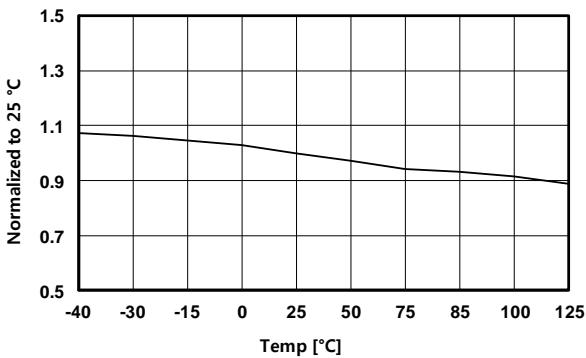

Figure 9. f<sub>MAX\_CC</sub> vs. Temperature

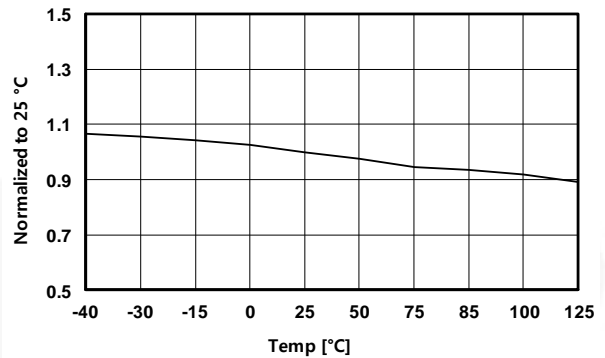

Figure 10. f<sub>MIN\_CC</sub> vs. Temperature



Typical Performance Characteristics (Continued)

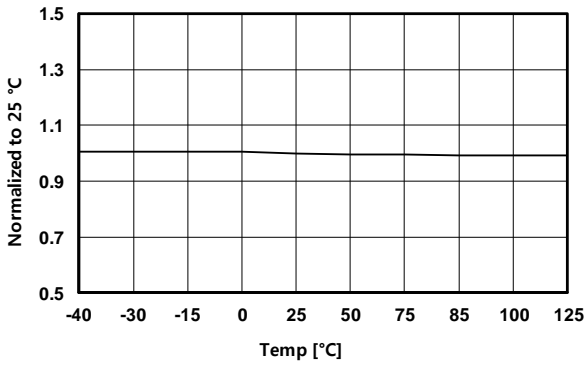

Figure 11.  $V_{CCR}$  vs. Temperature

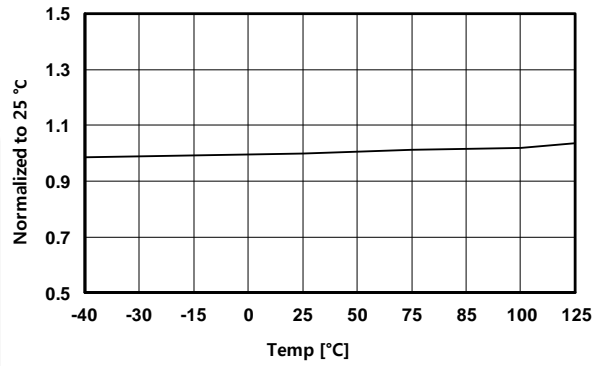

Figure 12.  $V_{VVR}$  vs. Temperature

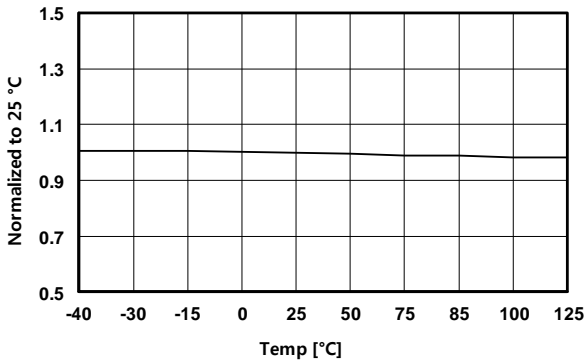

Figure 13.  $V_{OCP}$  vs. Temperature

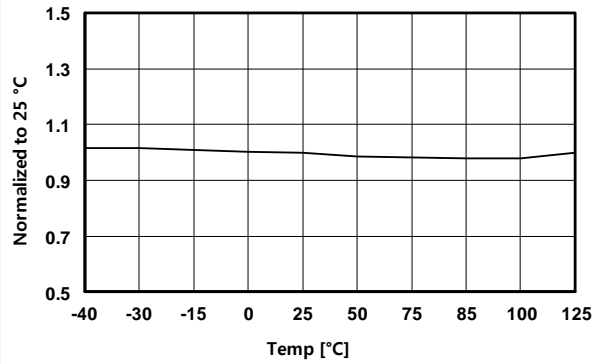

Figure 14.  $V_{OCP\_Low}$  vs. Temperature

## Functional Description

FL6632 is AC-DC PWM controller for LED lighting applications. TRUECURRENT™ techniques regulate accurate LED current independent of input voltage, output voltage, and magnetizing inductance variations. The linear frequency control in the oscillator reduces conduction loss and maintains DCM operation in the wide range of output voltage, which implements high power factor correction in a single-stage flyback topology. A variety of protections, such as short/open-LED protection, over-temperature protection, and cycle-by-cycle current limitation stabilize system operation and protect external components.

## Startup

Powering at startup is slow due to the low feedback loop bandwidth in PFC converter. To boost powering during startup, an internal oscillator counts 12ms to define Startup Mode. During Startup Mode, turn-on time is determined by Current-Mode control with a  $0.2 V_{CS}$  voltage limit and transconductance becomes 14 times larger, as shown in Figure 15. After startup, turn-on time is controlled by Voltage Mode using COM1 voltage and error amplifier transconductance is reduced to  $85 \mu\text{mho}$ .

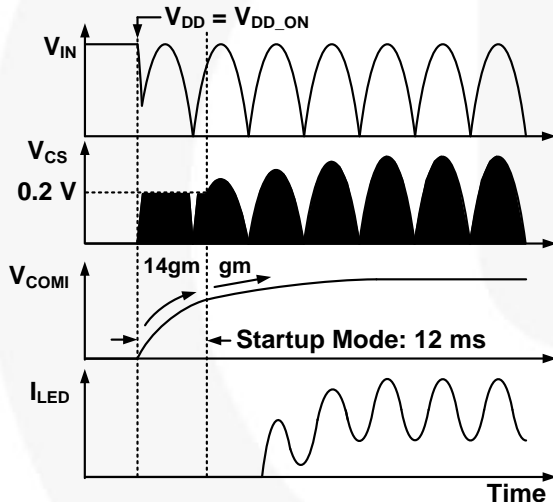

Figure 15. Startup Sequence

## Constant-Current Regulation

The output current can be estimated using the peak drain current and inductor current discharge time since output current is same as the average of the diode current in steady state. The peak value of the drain current is determined by the CS pin and the inductor discharge time ( $t_{dis}$ ) is sensed by  $t_{dis}$  detector. By using three points of information (peak drain current, inductor discharging time, and operating switching period); the TRUECURRENT™ calculation block estimates output current. The output of the calculation is compared with an internal precise reference to generate an error voltage ( $V_{COM1}$ ), which determines turn-on time in Voltage-Mode control. With Fairchild's innovative TRUECURRENT™ technique, constant-current output can be precisely controlled.

## PFC and THD

In a conventional boost converter, Boundary Conduction Mode (BCM) is generally used to keep input current in-phase with input voltage for PF and THD. In flyback/buck boost topology, constant turn-on time and constant frequency in Discontinuous Conduction Mode (DCM) can implement high PF and low THD, as shown in Figure 16. Constant turn-on time is maintained by the internal error amplifier and a large external capacitor (typically over  $1 \mu\text{F}$ ) at the COM1 pin. Constant frequency and DCM operation are managed by linear frequency control.

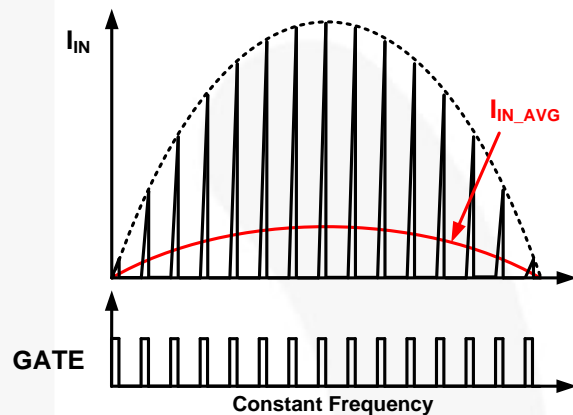

Figure 16. Input Current and Switching

## DCM Control

As mentioned above, DCM should be guaranteed for high power factor in flyback topology. To maintain DCM across a wide range of output voltage, the switching frequency is linearly adjusted by the output voltage in linear frequency control in the whole  $V_s$  range. Output voltage is detected by the auxiliary winding and the resistive divider connected to the VS pin, as shown in Figure 17. When the output voltage decreases, secondary diode conduction time is increased and the DCM control lengthens the switching period, which retains DCM operation over the wide output voltage range, as shown in Figure 18. The frequency control lowers the primary rms current with better power efficiency in full-load condition.

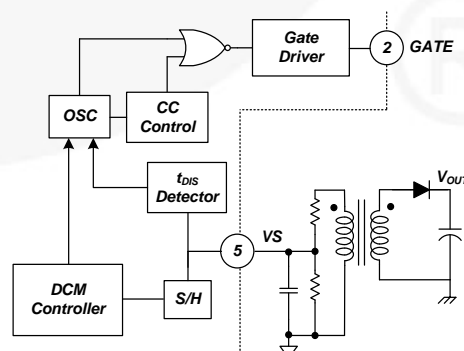

Figure 17. DCM and BCM Control

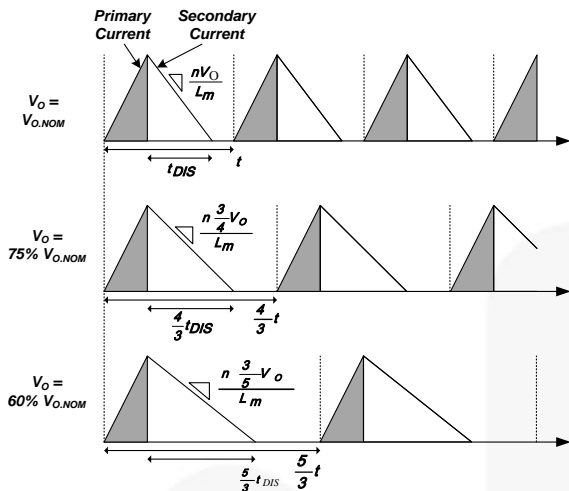

Figure 18. Primary and Secondary Current

### BCM Control

The end of secondary diode conduction time could possibly be behind the end of a switching period set by DCM control. In this case, the next switching cycle starts at the end of secondary diode conduction time since FL6632 doesn't allow CCM. Consequently, the operation mode changes from DCM to Boundary Conduction Mode (BCM).

### Short-LED Protection

In case of a short-LED condition, the switching MOSFET and secondary diode are stressed by the high powering current. However, FL6632 changes the OCP level in a short-LED condition. When  $V_S$  voltage is lower than 0.4 V, OCP level becomes 0.2 V from 0.7 V, as shown in Figure 19, so powering is limited and external components current stress is reduced.

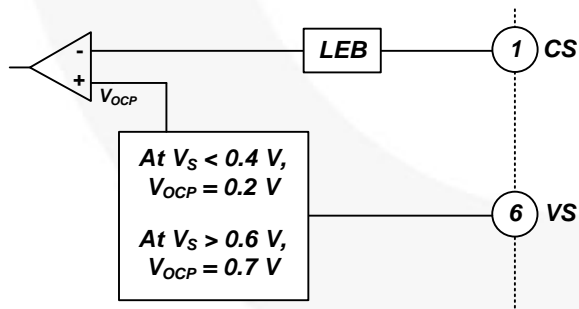

Figure 19. Internal OCP Block

Figure 20 shows operational waveforms in short-LED condition. Output voltage is quickly lowered to 0 V right after a short-LED event. Then the reflected auxiliary voltage is also 0 V, making  $V_S$  less than 0.4 V. 0.2 V OCP level limits primary-side current and  $V_{DD}$  hiccups up and down between UVLO hysteresis.

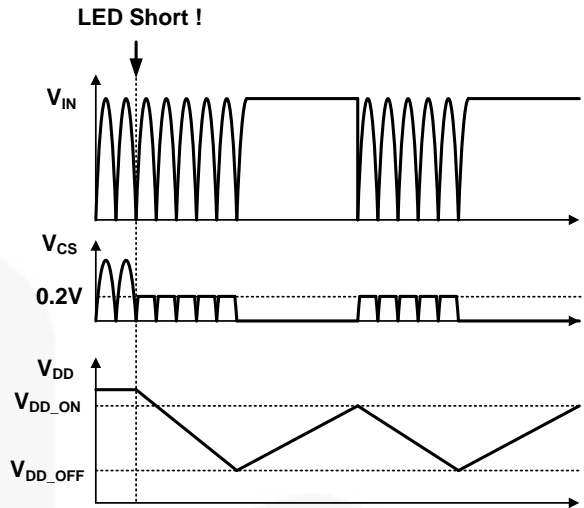

Figure 20. Waveforms in Short-LED Condition

### Open-LED Protection

FL6632 protects external components, such as diode and capacitor, at secondary side in open-LED condition. During switch-off, the  $V_{DD}$  capacitor is charged up to the auxiliary winding voltage, which is applied as the reflected output voltage. Because the  $V_{DD}$  voltage has output voltage information, the internal voltage comparator on the  $V_{DD}$  pin can trigger output Over-Voltage Protection (OVP), as shown in Figure 21. When at least one LED is open-circuited, output load impedance becomes very high and output capacitor is quickly charged up to  $V_{OVP} \times N_S / N_A$ . Then switching is shut down and the  $V_{DD}$  block goes into Hiccup Mode until the open-LED condition is removed, as shown in Figure 22.

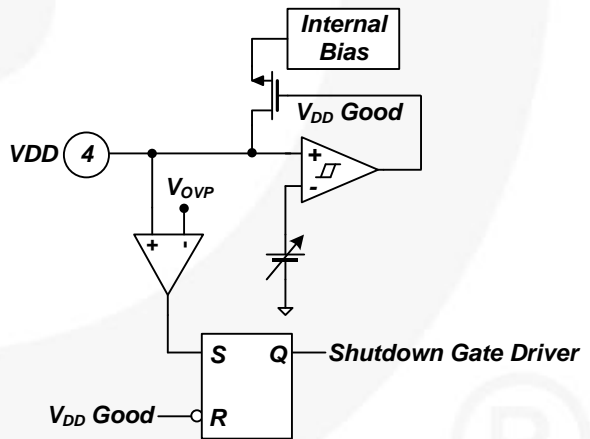

Figure 21. Internal OVP Block

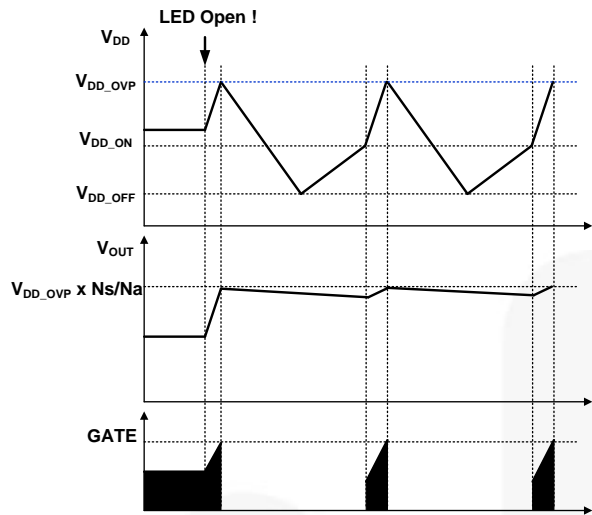

Figure 22. Waveforms in Open-LED Condition

### Under-Voltage Lockout (UVLO)

The turn-on and turn-off thresholds are fixed internally at 16 V and 7.5 V, respectively. During startup, the  $V_{DD}$  capacitor must be charged to 16 V through the startup resistor to enable the FL6632. The  $V_{DD}$  capacitor continues to supply  $V_{DD}$  until power can be delivered from the auxiliary winding of the main transformer.  $V_{DD}$  must not drop below 7.5 V during this startup process. This UVLO hysteresis window ensures that the  $V_{DD}$  capacitor is adequate to supply  $V_{DD}$  during startup.

### Over-Temperature Protection (OTP)

The FL6632 has a built-in temperature-sensing circuit to shut down PWM output if the junction temperature exceeds 150°C. While PWM output is shut down, the  $V_{DD}$  voltage gradually drops to the UVLO voltage. Some of the internal circuits are shut down and  $V_{DD}$  gradually starts increasing again. When  $V_{DD}$  reaches 16 V, all the internal circuits start operating. If the junction temperature is still higher than 140°C, the PWM controller is shut down immediately.

## PCB Layout Guidance

PCB layout for a power converter is as important as circuit design because PCB layout with high parasitic inductance or resistance can lead to severe switching noise with system instability. PCB should be designed to minimize switching noise into control signals.

1. The signal ground and power ground should be separated and connected only at one position (GND pin) to avoid ground loop noise. The power ground path from the bridge diode to the sensing resistors should be short and wide.
2. Gate-driving current path (GATE –  $R_{GATE}$  – MOSFET –  $R_{CS}$  – GND) must be as short as possible.

3. Control pin components; such as  $C_{COM1}$ ,  $C_{VS}$ , and  $R_{VS2}$ ; should be placed close to the assigned pin and signal ground.
4. High-voltage traces related to the drain of MOSFET and RCD snubber should be kept far way from control circuits to avoid unnecessary interference.
5. If a heat sink is used for the MOSFET, connect this heat sink to power ground.
6. The auxiliary winding ground should be connected closer to the GND pin than the control pin components' ground.

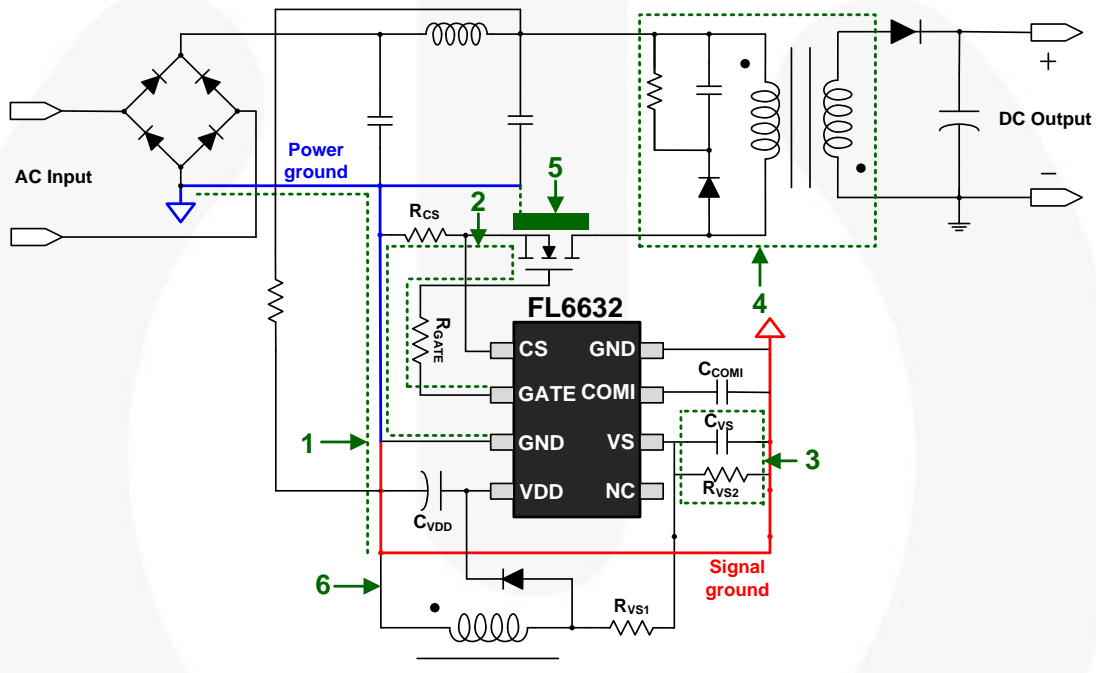
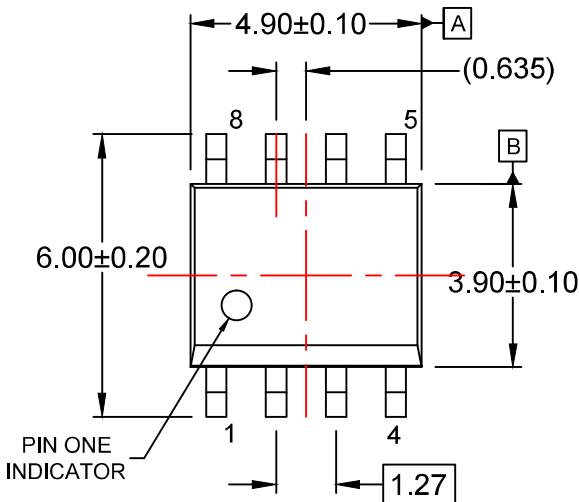
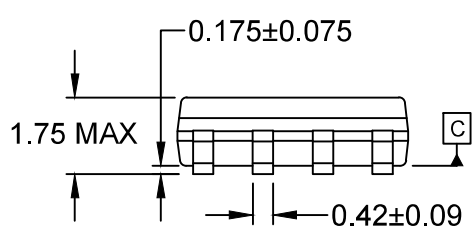
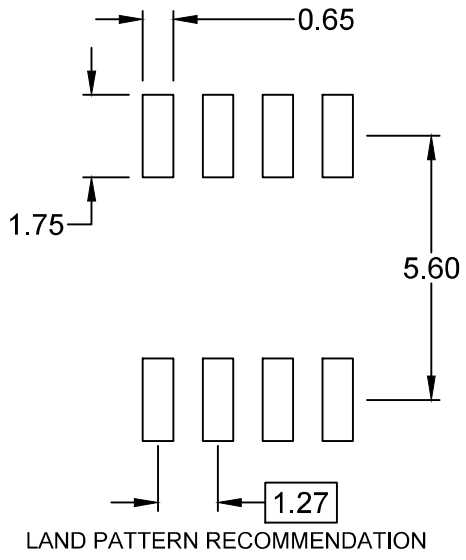

Figure 23. Layout Example



⊕ 0.25(M) C B A



0.10

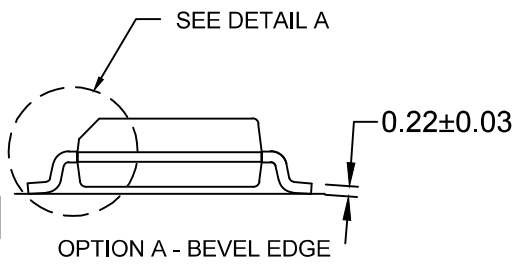

OPTION A - BEVEL EDGE

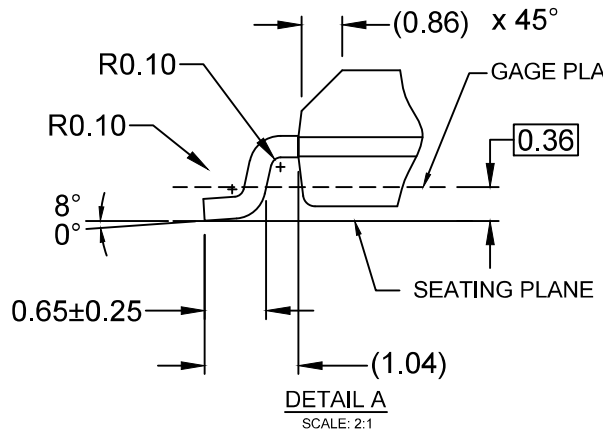

DETAIL A  
SCALE: 2:1

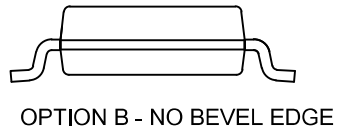

OPTION B - NO BEVEL EDGE

NOTES:

- A) THIS PACKAGE CONFORMS TO JEDEC MS-012, VARIATION AA.
- B) ALL DIMENSIONS ARE IN MILLIMETERS.
- C) DIMENSIONS DO NOT INCLUDE MOLD FLASH OR BURRS.
- D) LANDPATTERN STANDARD: SOIC127P600X175-8M
- E) DRAWING FILENAME: M08Arev16



ON Semiconductor and  are trademarks of Semiconductor Components Industries, LLC dba ON Semiconductor or its subsidiaries in the United States and/or other countries. ON Semiconductor owns the rights to a number of patents, trademarks, copyrights, trade secrets, and other intellectual property. A listing of ON Semiconductor's product/patent coverage may be accessed at [www.onsemi.com/site/pdf/Patent-Marking.pdf](http://www.onsemi.com/site/pdf/Patent-Marking.pdf). ON Semiconductor reserves the right to make changes without further notice to any products herein. ON Semiconductor makes no warranty, representation or guarantee regarding the suitability of its products for any particular purpose, nor does ON Semiconductor assume any liability arising out of the application or use of any product or circuit, and specifically disclaims any and all liability, including without limitation special, consequential or incidental damages. Buyer is responsible for its products and applications using ON Semiconductor products, including compliance with all laws, regulations and safety requirements or standards, regardless of any support or applications information provided by ON Semiconductor. "Typical" parameters which may be provided in ON Semiconductor data sheets and/or specifications can and do vary in different applications and actual performance may vary over time. All operating parameters, including "Typicals" must be validated for each customer application by customer's technical experts. ON Semiconductor does not convey any license under its patent rights nor the rights of others. ON Semiconductor products are not designed, intended, or authorized for use as a critical component in life support systems or any FDA Class 3 medical devices or medical devices with a same or similar classification in a foreign jurisdiction or any devices intended for implantation in the human body. Should Buyer purchase or use ON Semiconductor products for any such unintended or unauthorized application, Buyer shall indemnify and hold ON Semiconductor and its officers, employees, subsidiaries, affiliates, and distributors harmless against all claims, costs, damages, and expenses, and reasonable attorney fees arising out of, directly or indirectly, any claim of personal injury or death associated with such unintended or unauthorized use, even if such claim alleges that ON Semiconductor was negligent regarding the design or manufacture of the part. ON Semiconductor is an Equal Opportunity/Affirmative Action Employer. This literature is subject to all applicable copyright laws and is not for resale in any manner.

## PUBLICATION ORDERING INFORMATION

### LITERATURE FULFILLMENT:

Literature Distribution Center for ON Semiconductor  
19521 E. 32nd Pkwy, Aurora, Colorado 80011 USA  
**Phone:** 303-675-2175 or 800-344-3860 Toll Free USA/Canada  
**Fax:** 303-675-2176 or 800-344-3867 Toll Free USA/Canada  
**Email:** [orderlit@onsemi.com](mailto:orderlit@onsemi.com)

**N. American Technical Support:** 800-282-9855 Toll Free  
USA/Canada  
**Europe, Middle East and Africa Technical Support:**  
Phone: 421 33 790 2910  
**Japan Customer Focus Center**  
Phone: 81-3-5817-1050

**ON Semiconductor Website:** [www.onsemi.com](http://www.onsemi.com)  
**Order Literature:** <http://www.onsemi.com/orderlit>  
For additional information, please contact your local  
Sales Representative

## X-ON Electronics

Largest Supplier of Electrical and Electronic Components

*Click to view similar products for [LED Lighting Drivers](#) category:*

*Click to view products by [ON Semiconductor](#) manufacturer:*

Other Similar products are found below :

[LV5235V-MPB-H](#) [MB39C602PNF-G-JNEFE1](#) [MIC2871YMK-T5](#) [AL1676-10BS7-13](#) [AL1676-20AS7-13](#) [AP5726WUG-7](#) [ICL8201](#)  
[IS31BL3228B-UTLS2-TR](#) [IS31BL3506B-TTLS2-TR](#) [AL3157F-7](#) [AP5725FDCG-7](#) [AP5726FDCG-7](#) [LV52204MTTBG](#) [AP5725WUG-7](#)  
[STP4CMPQTR](#) [NCL30086BDR2G](#) [CAT4004BHU2-GT3](#) [LV52207AXA-VH](#) [AP1694AS-13](#) [TLE4242EJ](#) [AS3688](#) [IS31LT3172-GRLS4-TR](#)  
[TLD2311EL](#) [KTD2694EDQ-TR](#) [KTZ8864EJAA-TR](#) [IS32LT3174-GRLA3-TR](#) [MP2488DN-LF-Z](#) [NLM0010XTSA1](#) [AL1676-20BS7-13](#)  
[ZXLD1370QESTTC](#) [MPQ7220GF-AEC1-P](#) [MPQ7220GR-AEC1-P](#) [MPQ4425BGJ-AEC1-P](#) [MPQ7220GF-AEC1-Z](#) [MPQ7220GR-AEC1-Z](#)  
[MPQ4425BGJ-AEC1-Z](#) [NCL30486A2DR2G](#) [IS31FL3737B-QFLS4-TR](#) [IS31FL3239-QFLS4-TR](#) [KTD2058EUAC-TR](#) [KTD2037EWE-TR](#)  
[DIO5662ST6](#) [IS31BL3508A-TTLS2-TR](#) [KTD2026BEWE-TR](#) [MAX20052CATC/V+](#) [MAX25606AUP/V+](#) [BD6586MUV-E2](#) [BD9206EFV-E2](#) [BD9416FS-E2](#) [LYT4227E](#)