

Primary-Side-Regulated LED Driver with Power Factor Correction



FL7733A

Description

The FL7733A is a highly-integrated PWM controller with advanced Primary-Side Regulation (PSR) technique to minimize components in low-to-mid-power LED lighting converters.

Using an innovative TRUECURRENT® technology to provide tight tolerance constant-current output, this LED driver enables designs with constant current (CC) tolerance of less than ±1% over the universal line voltage range to meet stringent LED brightness requirements.

By minimizing turn-on time fluctuation, high power factor and low THD over the universal line range are obtained in the FL7733A. An integrated high-voltage startup circuit implements fast startup and high system efficiency. During startup, adaptive feedback loop control anticipates the steady-state condition and sets initial feedback condition close to the steady state to ensure no overshoot or undershoot of LED current.

The FL7733A also provides powerful protections, such as LED short / open, output diode short, sensing resistor short / open, and over-temperature for high system reliability.

The FL7733A controller is available in an 8-pin Small-Outline Package (SOP).

Features

Performance

- <±3% Total Constant Current Tolerance Over All Conditions
 - <±1% Over Universal Line Voltage Variation
 - <±1% from 50% to 100% Load Voltage Variation
 - <±1% with ±20% Magnetizing Inductance Variation
- Primary-Side Regulation (PSR) Control for Cost-Effective Solution without Requiring Input Bulk Capacitor and Secondary Feedback Circuitry
- Application Input Voltage Range: 80 V_{AC} – 308 V_{AC}
- High PF of >0.9, and Low THD of <10% Over Universal Line Input Range
- Fast <200 ms Start-up (at 85 V_{AC}) Using Internal High-Voltage Startup with V_{DD} Regulation
- Adaptive Feedback Loop Control for Startup without Overshoot

System Protection

- LED Short / Open Protection
- Output Diode Short Protection
- Sensing Resistor Short / Open Protection
- V_{DD} Over-Voltage Protection (OVP)
- V_{DD} Under-Voltage Lockout (UVLO)

MARKING DIAGRAM

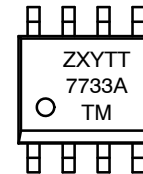

- 7733A = Device Code
- Z = Plant Code
- X = 1-Digit Year Code
- Y = 1-Digit Week Code
- TT = 2-Digit Die Run Code
- T = Package Type (M = SOP)
- M = Manufacture Flow Code

PIN CONFIGURATION

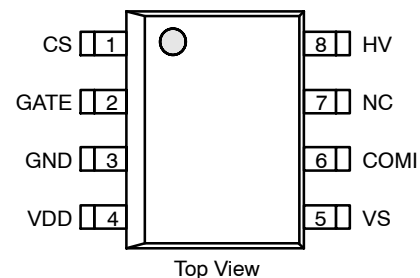

Top View

ORDERING INFORMATION

See detailed ordering and shipping information on page 12 of this data sheet.

System Protection (continued)

- All Protections are Auto Restart (AR)
- Cycle-by-Cycle Current Limit
- Over-Temperature Protection (OTP)
- All Protections are Auto Restart (AR)
- Cycle-by-Cycle Current Limit

Applications

- Low to Mid Power LED Lighting Systems of 5 W to Greater than 60 W Compatible with Analog Dimming Function

Related Product Resources

[FL7733A Product Folder](#)

FL7733A

APPLICATION DIAGRAM

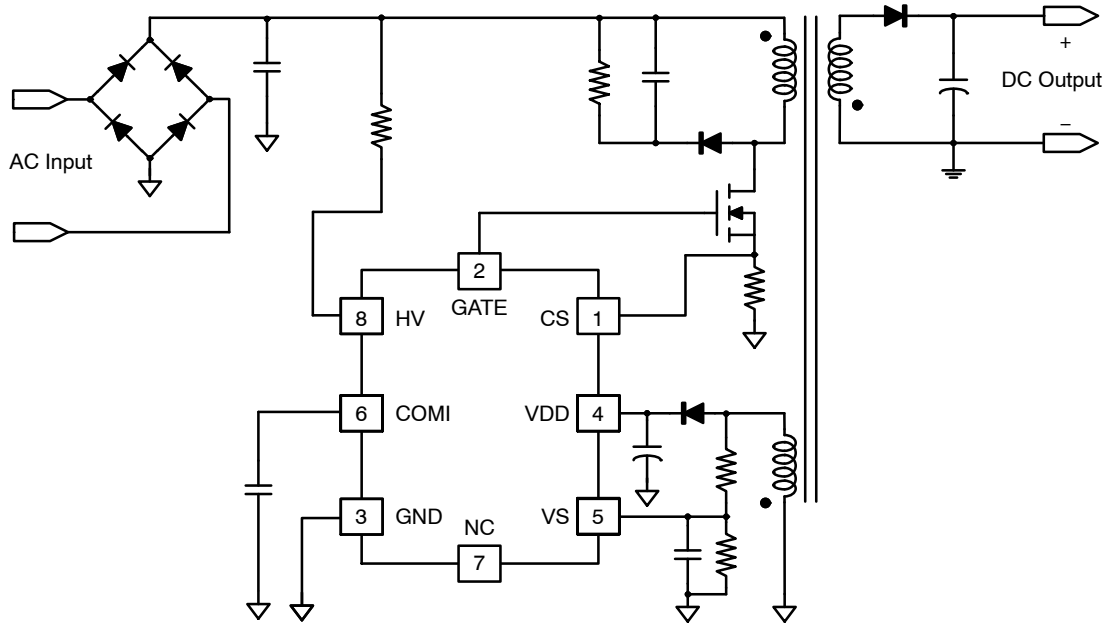

Figure 1. Typical Application

BLOCK DIAGRAM

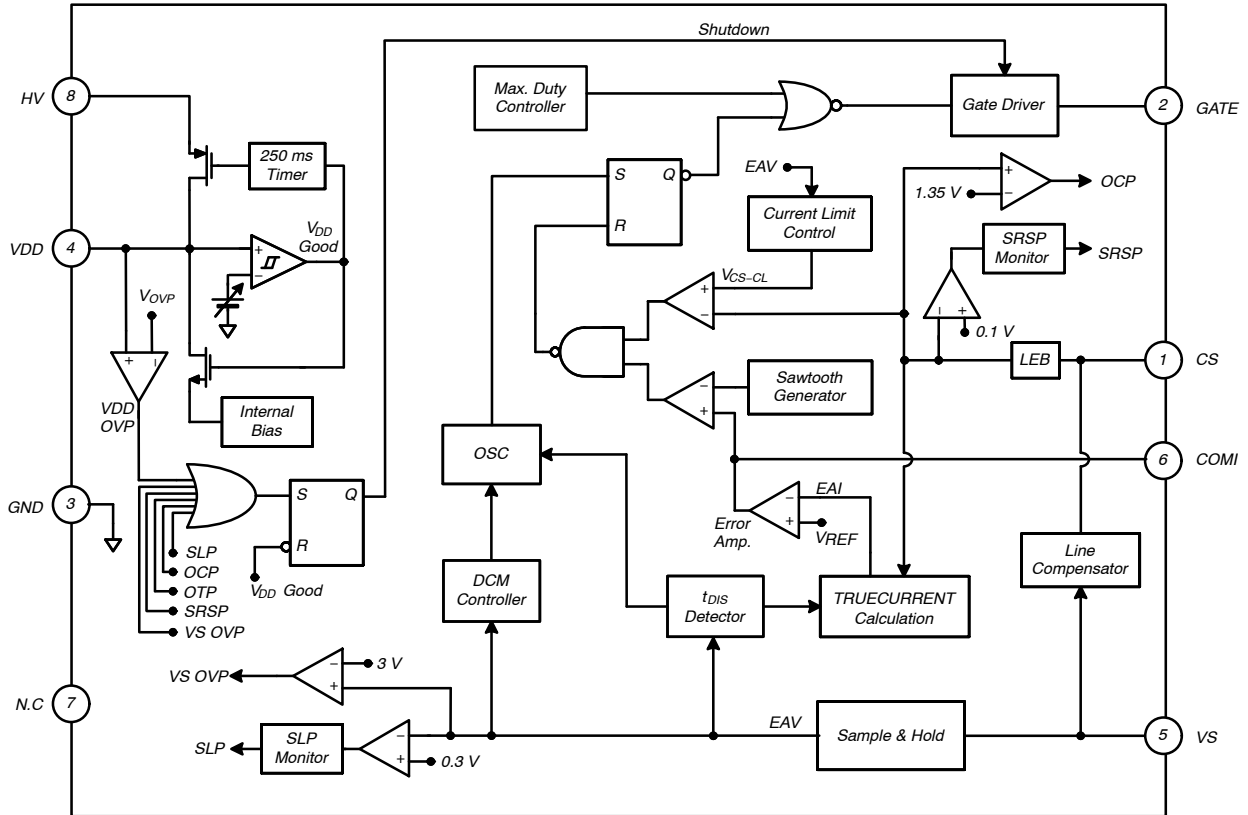

Figure 2. Functional Block Diagram

FL7733A

PIN DESCRIPTION

Pin No.	Name	Description
1	CS	<i>Current Sense.</i> This pin connects a current-sense resistor to detect the MOSFET current for constant output current regulation.
2	GATE	<i>PWM Signal Output.</i> This pin uses the internal totem-pole output driver to drive the power MOSFET.
3	GND	<i>Ground</i>
4	VDD	<i>Power Supply.</i> IC operating current and MOSFET driving current are supplied using this pin.
5	VS	<i>Voltage Sense.</i> This pin detects the output voltage and discharge time information for CC regulation. This pin is connected to the auxiliary winding of the transformer via a resistor divider.
6	COMI	<i>Constant Current Loop Compensation.</i> This pin is connected to a capacitor between COMI and GND for compensating the current loop gain.
7	NC	No Connect
8	HV	<i>High Voltage.</i> This pin is connected to the rectified input voltage via a resistor.

ABSOLUTE MAXIMUM RATINGS

Symbol	Parameter	Min	Max	Unit
HV	HV Pin Voltage	–	700	V
V _{VDD}	DC Supply Voltage (Note 1, 2)	–	30	V
V _{VS}	VS Pin Input Voltage	–0.3	6.0	V
V _{CS}	CS Pin Input Voltage	–0.3	6.0	V
V _{COMI}	COMI Pin Input Voltage	–0.3	6.0	V
V _{GATE}	GATE Pin Input Voltage	–0.3	30.0	V
P _D	Power Dissipation (T _A < 50°C)	–	633	mW
T _J	Maximum Junction Temperature	–	150	°C
T _{STG}	Storage Temperature Range	–55	150	°C
T _L	Lead Temperature (Soldering) 10 Seconds	–	260	°C

Stresses exceeding those listed in the Maximum Ratings table may damage the device. If any of these limits are exceeded, device functionality should not be assumed, damage may occur and reliability may be affected.

1. Stresses beyond those listed under Absolute Maximum Ratings may cause permanent damage to the device.
2. All voltage values, except differential voltages, are given with respect to GND pin.

THERMAL IMPEDANCE (T_A = 25°C, unless otherwise specified.)

Symbol	Parameter	Value	Unit
θ _{JA}	Junction-to-Ambient Thermal Impedance	158	°C/W
θ _{JC}	Junction-to-Case Thermal Impedance	39	°C/W

3. Referenced the JEDEC recommended environment, JESD51-2, and test board, JESD51-3, 1S1P with minimum land pattern.

ESD CAPABILITY

Symbol	Parameter	Value	Unit
ESD	Human Body Model, ANSI/ESDA/JEDEC JS-001-2012	5	kV
	Charged Device Model, JESD22-C101	2	

4. Meets JEDEC standards JESD22-A114 and JESD 22-C101.

FL7733A

ELECTRICAL CHARACTERISTICS ($V_{DD} = 15\text{ V}$, $T_J = -40\text{ to }+125^\circ\text{C}$, unless otherwise specified. Currents are defined as positive into the device and negative out of device.)

Symbol	Parameter	Test Condition	Min	Typ	Max	Unit
V_{DD-ON}	Turn-On Threshold Voltage		14.5	16.0	17.5	V
V_{DD-OFF}	Turn-Off Threshold Voltage		6.75	7.75	8.75	V
I_{DD-OP}	Operating Current	$C_L = 1\text{ nF}$, $f = f_{MAX-CC}$	3	4	5	mA
I_{DD-ST}	Startup Current	$V_{DD} = V_{DD-ON} - 1.6\text{ V}$	-	30	50	μA
$V_{VDD-OVP}$	V_{DD} Over-Voltage Protection Level		23	24	25	V

GATE SECTION

V_{OL}	Output Voltage Low	$T_A = 25^\circ\text{C}$, $V_{DD} = 20\text{ V}$, $I_{DD_GATE} = 1\text{ mA}$	-	-	1.5	V
V_{OH}	Output Voltage High	$T_A = 25^\circ\text{C}$, $V_{DD} = 10\text{ V}$, $I_{DD} = 1\text{ mA}$	5	-	-	V
I_{SOURCE}	Peak Sourcing Current (Note 5)	$V_{DD} = 10\sim 20\text{ V}$	-	-60	-	mA
I_{SINK}	Peak Sinking Current (Note 5)	$V_{DD} = 10\sim 20\text{ V}$	-	180	-	mA
t_R	Rising Time	$T_A = 25^\circ\text{C}$, $V_{DD} = 15\text{ V}$, $C_{LOAD} = 1\text{ nF}$	100	150	200	ns
t_F	Falling Time	$T_A = 25^\circ\text{C}$, $V_{DD} = 15\text{ V}$, $C_{LOAD} = 1\text{ nF}$	20	60	100	ns
V_{CLAMP}	Output Clamp Voltage	$V_{DD} = 20\text{ V}$, $V_{CS} = 0\text{ V}$, $V_{VS} = 0\text{ V}$, $V_{COM} = 0\text{ V}$	12	15	18	V

HV STARTUP SECTION

I_{HV}	Supply Current From HV Pin	$T_A = 25^\circ\text{C}$, $V_{IN} = 90\text{ V}_{AC}$, $V_{DD} = 0\text{ V}$	-	-	9	mA
I_{HV-LC}	Leakage Current after Startup		-	1	10	μA
t_{R-JFET}	JFET Regulation Time after Startup (Note 5)	$T_A = 25^\circ\text{C}$	190	250	310	ms
$V_{JFET-HL}$	JFET Regulation High Limit Voltage		17.5	19.0	20.5	V
$V_{JFET-LL}$	JFET Regulation Low Limit Voltage		11.5	13.0	14.5	V

CURRENT-ERROR-AMPLIFIER SECTION

g_m	Transconductance (Note 5)	$T_A = 25^\circ\text{C}$	11	17	23	μmho
$I_{COMI-SINK}$	COMI Sink Current	$T_A = 25^\circ\text{C}$, $V_{EAI} = 2.55\text{ V}$, $V_{COMI} = 5\text{ V}$	12	18	24	μA
$I_{COMI-SOURCE}$	COMI Source Current	$T_A = 25^\circ\text{C}$, $V_{EAI} = 0.45\text{ V}$, $V_{COMI} = 0\text{ V}$	12	18	24	μA
$V_{COMI-HGH}$	COMI High Voltage	$V_{EAI} = 0\text{ V}$	4.7	-	-	V
$V_{COMI-LOW}$	COMI Low Voltage	$V_{EAI} = 5\text{ V}$	-	-	0.1	V
$V_{COMI_INT.CLP}$	Initial COMI Clamping Voltage (Note 5)		-	1.2	-	V
$t_{COMI_INT.CLP}$	Time for Initial COMI Clamping (Note 5)		-	15	-	ms

VOLTAGE-SENSE SECTION

$t_{DIS-BNK}$	t_{DIS} Blanking Time of V_S (Note 5)		0.85	1.15	1.45	μs
I_{VS-BNK}	V_S Current for V_S Blanking		-75	-90	-105	μA
V_{VS-OVP}	V_S Level for Output Over-Voltage Protection		2.95	3.00	3.15	V
$V_{VS-LOW-CL-EN}$	V_S Threshold Voltage to Enable Low Current Limit (Note 5)		0.25	0.30	0.35	V
$V_{VS-HIGH-CL-DIS}$	V_S Threshold Voltage to Disable Low Current Limit (Note 5)		0.54	0.60	0.66	V
$V_{VS-SLP-TH}$	V_S Threshold Voltage for Output Short-LED Protection		0.25	0.30	0.35	V
$t_{SLP-BNK}$	V_S Detection Disable Time after Startup (Note 5)	$T_A = 25^\circ\text{C}$	-	15	-	ms

FL7733A

ELECTRICAL CHARACTERISTICS ($V_{DD} = 15\text{ V}$, $T_J = -40\text{ to }+125^\circ\text{C}$, unless otherwise specified. Currents are defined as positive into the device and negative out of device.) (continued)

Symbol	Parameter	Test Condition	Min	Typ	Max	Unit
--------	-----------	----------------	-----	-----	-----	------

CURRENT-SENSE SECTION

V_{RV}	Reference Voltage	$T_A = 25^\circ\text{C}$	1.485	1.500	1.515	V
t_{LEB}	Leading-Edge Blanking Time (Note 5)		-	300	-	ns
t_{MIN}	Minimum On Time in CC (Note 5)	$V_{COMI} = 0\text{ V}$	-	500	-	ns
t_{PD}	Propagation Delay to GATE Output		50	100	150	ns
$V_{CS-HIGH-CL}$	High Current Limit Threshold		0.9	1.0	1.1	V
$V_{CS-LOW-CL}$	Low Current Limit Threshold		0.16	0.20	0.24	V
t_{LOW-CM}	Low Current Mode Operation Time at Startup (Note 5)		-	20	-	ms
$V_{CS-SRSP}$	V_{CS} Threshold Voltage for Sensing Resistor Short Protection		-	-	0.1	V
V_{CS-OC}	V_{CS} Threshold Voltage for Over-Current Protection	$T_A = 25^\circ\text{C}$	1.20	1.35	1.50	V
V_{CS} / I_{VS}	Relation of Line Compensation Voltage and V_S Current (Note 5)		-	21.5	-	V/A

OSCILLATOR SECTION

f_{MAX-CC}	Maximum Frequency in CC	$T_A = 25^\circ\text{C}$, $V_S = 3.0\text{ V}$	65	70	75	kHz
f_{MIN-CC}	Minimum Frequency in CC	$T_A = 25^\circ\text{C}$, $V_S = 0.3\text{ V}$	23.0	26.5	30.0	kHz
t_{ON-MAX}	Maximum Turn-On Time	$T_A = 25^\circ\text{C}$, $f = f_{MAX-CC}$	11.0	13.0	15.0	μs

OVER-TEMPERATURE-PROTECTION SECTION

T_{OTP}	Threshold Temperature for OTP (Note 5)		-	150	-	$^\circ\text{C}$
$T_{OTP-HYS}$	Restart Junction Temperature Hysteresis (Note 5)		-	10	-	$^\circ\text{C}$

Product parametric performance is indicated in the Electrical Characteristics for the listed test conditions, unless otherwise noted. Product performance may not be indicated by the Electrical Characteristics if operated under different conditions.

5. These parameters, although guaranteed by design, are not production tested.

TYPICAL PERFORMANCE CHARACTERISTICS

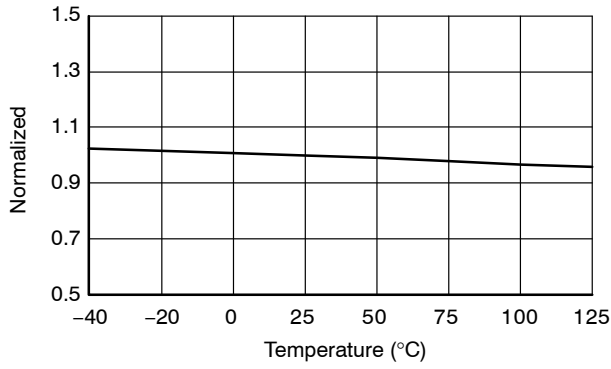

Figure 3. V_{DD-ON} vs. Temperature

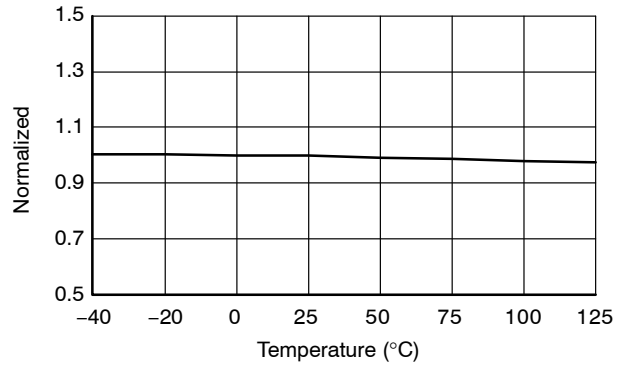

Figure 4. V_{DD-OFF} vs. Temperature

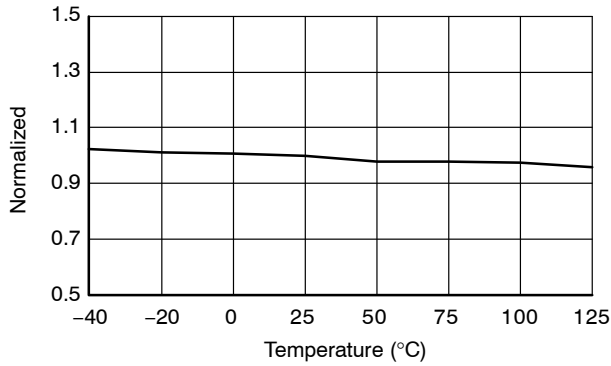

Figure 5. I_{DD-OP} vs. Temperature

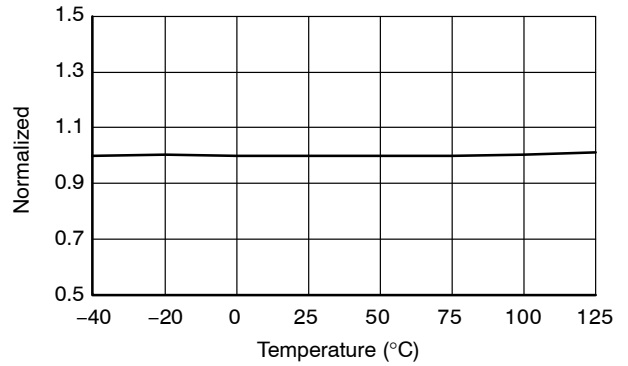

Figure 6. V_{DD-OVP} vs. Temperature

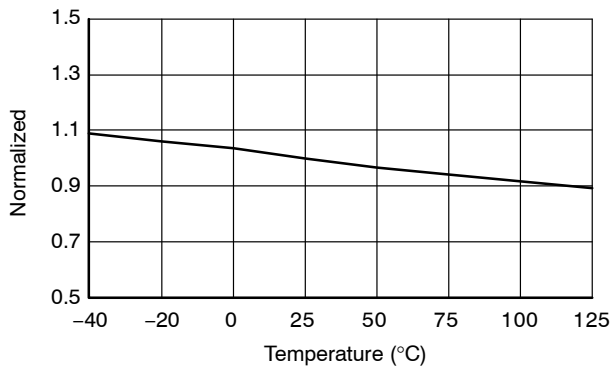

Figure 7. f_{MAX-CC} vs. Temperature

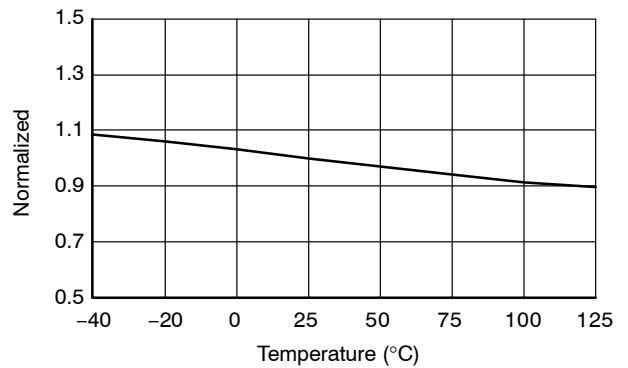

Figure 8. f_{MIN-CC} vs. Temperature

TYPICAL PERFORMANCE CHARACTERISTICS (Continued)

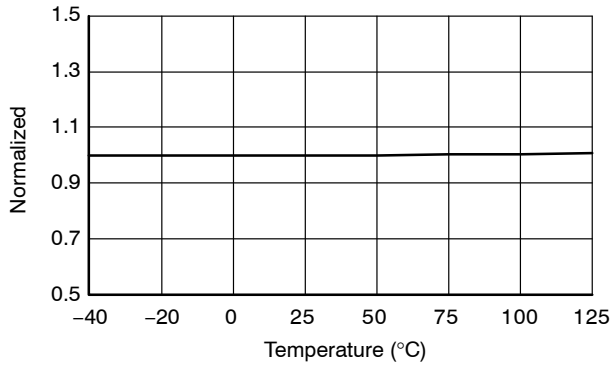

Figure 9. V_{VR} vs. Temperature

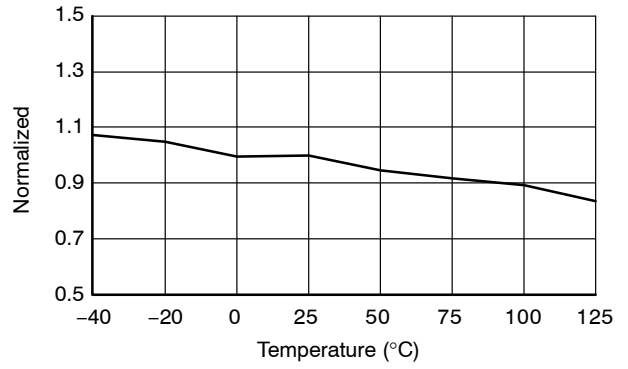

Figure 10. G_m vs. Temperature

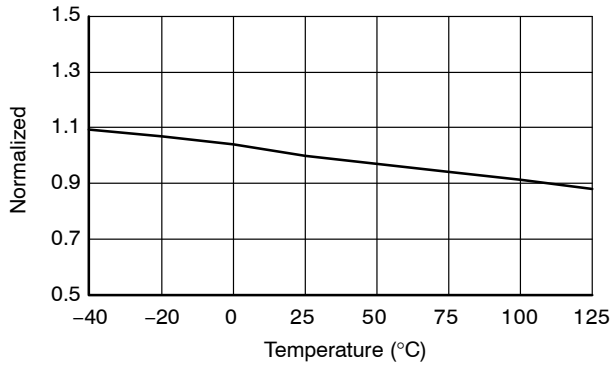

Figure 11. $I_{COMI-SOURCE}$ vs. Temperature

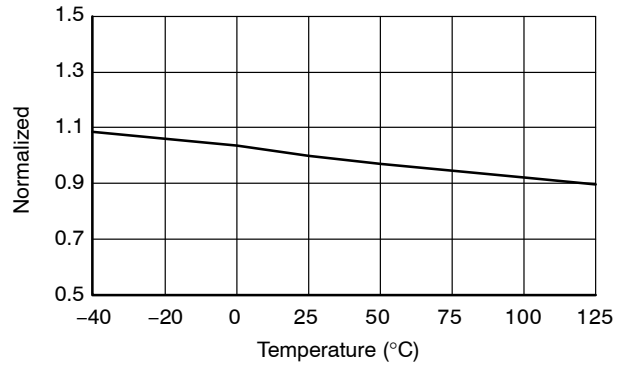

Figure 12. $I_{COMI-SINK}$ vs. Temperature

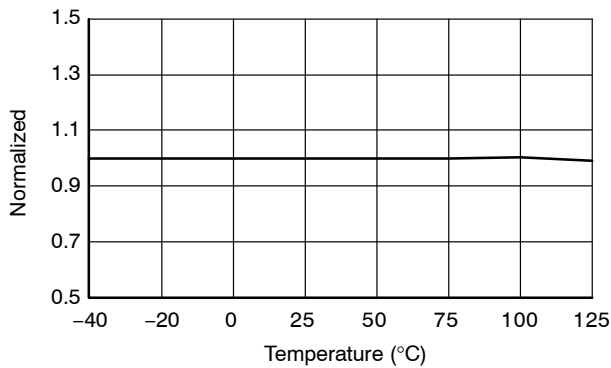

Figure 13. V_{VS-OVP} vs. Temperature

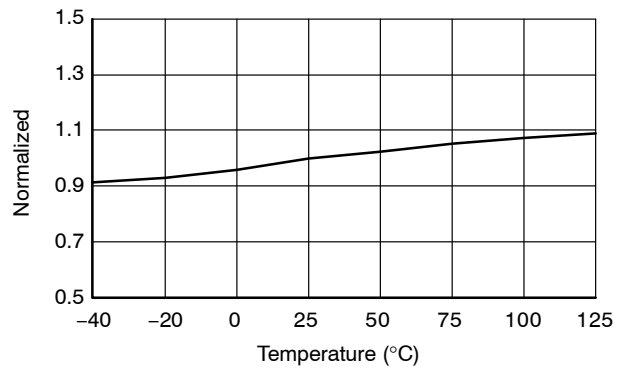

Figure 14. V_{CS-OCF} vs. Temperature

FUNCTIONAL DESCRIPTION

FL7733A is AC-DC PWM controller for LED lighting applications. TRUECURRENT technology regulate accurate constant LED current independent of input voltage, output voltage, and magnetizing inductance variations. The DCM control in the oscillator reduces conduction loss and maintains DCM operation over a wide range of output voltage, which implements high power factor correction in a single-stage flyback or buck-boost topology. A variety of protections, such as LED short / open protection, sensing resistor short / open protection, over-current protection, over-temperature protection, and cycle-by-cycle current limitation stabilize system operation and protect external components.

Startup

At startup, an internal high-voltage JFET supplies startup current and V_{DD} capacitor charging current, as shown in Figure 15. When V_{DD} reaches 16 V, switching begins and the internal high-voltage JFET continues to supply V_{DD} operating current for an initial 250 ms to maintain V_{DD} voltage higher than V_{DD-OFF} . As the output voltage increases, the auxiliary winding becomes the dominant V_{DD} supply current source.

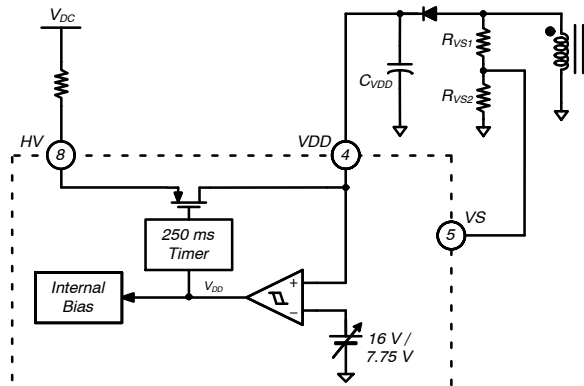

Figure 15. Startup Block

Switching is controlled by current-mode for 20 ms after V_{DD-ON} . During current-mode switching with the flyback or buck-boost topology, output current is only determined by output voltage. Therefore, the output voltage increases with constant slope, regardless of line voltage variation. Short-LED Protection (SLP) is enabled after the 15 ms SLP blanking time so that the output voltage is higher than SLP threshold voltage and successful startup is guaranteed without SLP in normal condition.

During current-mode switching, COMI voltage, which determines turn-on time in voltage mode, is adjusted close to the steady state level. The COMI capacitor is charged to 1.2 V for 15 ms and adjusted to a modulated level inversely proportional to V_{IN} peak value for 5 ms. Turn-on time right after 20 ms startup time can be controlled close to steady state on time so that voltage mode is smoothly entered without LED current overshoot or undershoot.

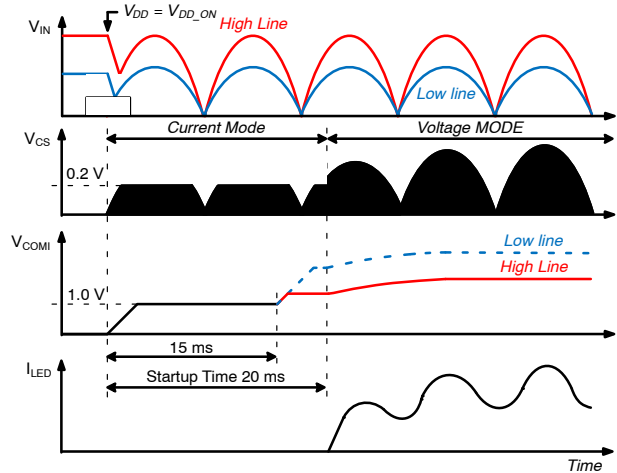

Figure 16. Startup Sequence

PFC and THD

In the flyback or the buck-boost topology, constant turn-on time and constant frequency in Discontinuous Conduction Mode (DCM) operation can achieve high PF and low THD, as shown in Figure 17. Constant turn-on time is maintained by the internal error amplifier and a large external COMI capacitor (typically over 1 μ F) at COMI pin. Constant frequency and DCM operation are managed by DCM control.

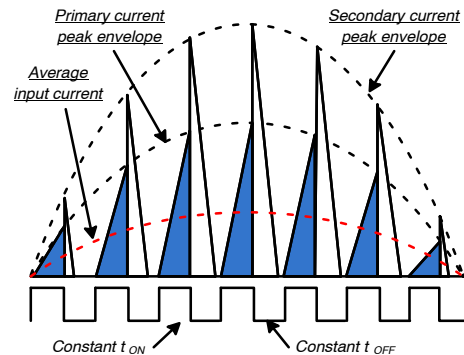

Figure 17. Power Factor Correction

Constant-Current Regulation

The output current can be estimated using the peak drain current and inductor current discharge time because output current is the same as the average of the diode current in steady state. The peak value of the drain current is determined by the CS peak voltage detector. The inductor current discharge time (t_{DIS}) is sensed by a t_{DIS} detector. With peak drain current, inductor current discharging time and operating switching period information, the TRUECURRENT calculation block estimates output current as follows:

$$I_o = \frac{1}{2} \cdot \frac{t_{DIS}}{t_s} \cdot V_{CS} \cdot \eta_{PS} \cdot \frac{1}{R_s} \quad (\text{eq. 1})$$

$$\frac{t_{DIS}}{t_S} \cdot V_{CS} = 0.25 \tag{eq. 2}$$

$$I_O = 0.125 \cdot \frac{n_{PS}}{R_S} \tag{eq. 3}$$

where, n_{PS} is the primary-to-secondary turn ratio and R_S is a sensing resistor connected between the source terminal of the MOSFET and ground.

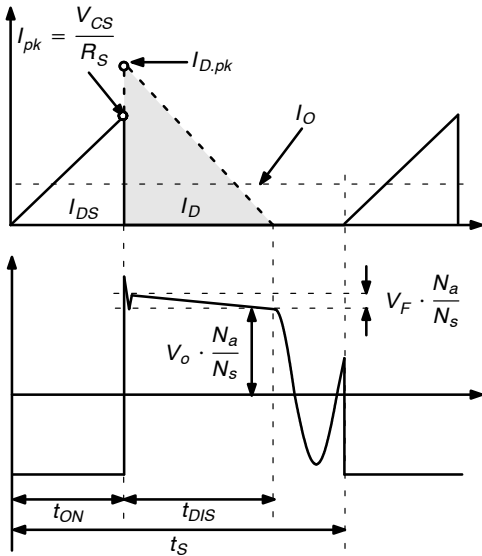

Figure 18. Key Waveforms for Primary-Side Regulation

The output of the current calculation is compared with an internal precise voltage reference to generate an error voltage (V_{COMI}), which determines the MOSFET’s turn-on time in voltage-mode control. With this innovative TRUECURRENT technology from onsemi, constant-current output can be precisely controlled. Although the output current is calculated with accurate method the output current at high input voltage may still be higher than that at low input voltage due to MOSFET’s turn off propagation delay caused by high Qg. To maintain tight CC regulation over the entire input voltage range, a line compensation resistor of 100~500 Ω can be inserted between the CS pin and the source terminal of the MOSFET. The voltage across by compensation resistor is dependent on current flow out of the CS pin for MOSFET turn-on and it is proportional to input voltage.

DCM Control

As mentioned above, DCM should be guaranteed for high power factor in flyback topology. To maintain DCM across a wide range of output voltage, the switching frequency is linearly adjusted by the output voltage in linear frequency control in the whole V_S range. Output voltage is detected by the auxiliary winding and the resistive divider connected to the VS pin, as shown in Figure 19. When the output voltage decreases, secondary diode conduction time is increased and the DCM control lengthens the switching period, which

retains DCM operation over the wide output voltage range, as shown in Figure 20. The frequency control lowers the primary rms current with better power efficiency in full-load condition.

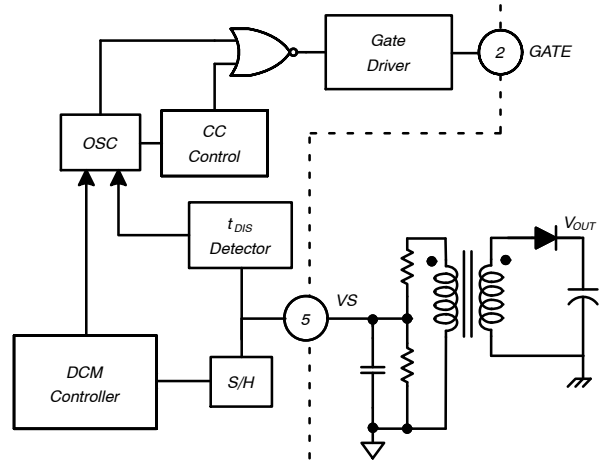

Figure 19. DCM and BCM Control

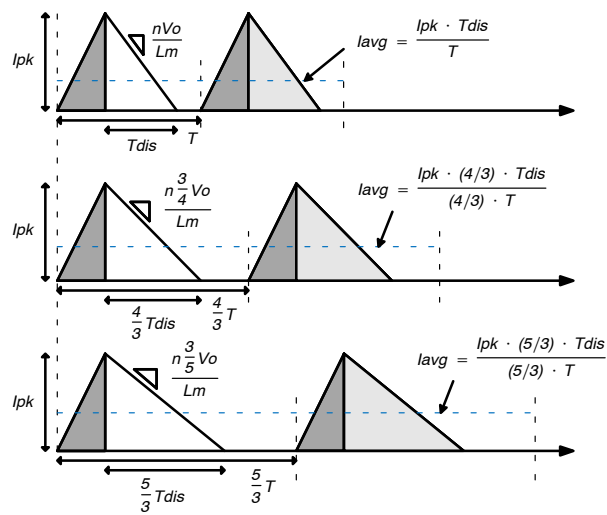

Figure 20. Primary and Secondary Current

BCM Control

The end of secondary diode conduction time could possibly be behind the end of a switching period set by DCM control. In this case, the next switching cycle starts at the end of secondary diode conduction time since FL7733A doesn’t allow CCM. Consequently, the operation mode changes from DCM to Boundary Conduction Mode (BCM).

Analog Dimming Function

Analog dimming function can be implemented by controlling COMI voltage which determines the turn-on time of main power MOSFET. Figure 21 shows an example analog dimming circuit for the FL7733A which uses a photo-coupler so the LED current can be controlled by the dimming signal, A-Dim, from the secondary side of the isolation transformer.

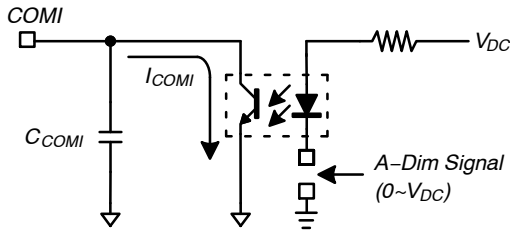

Figure 21. Analog Dimming Control

Short-LED Protection (SLP)

In case of a short-LED condition, the secondary diode is stressed by high current. When V_S voltage is lower than 0.3 V due to a short-LED condition, the cycle-by-cycle current limit level changes to 0.2 V from 1.0 V and SLP is triggered if the V_S voltage is less than 0.3 V for four (4) consecutive switching cycles. Figure 22 and Figure 23 show the SLP block and operational waveforms during LED-short condition. To set enough auto-restart time for system safety under protection conditions, V_{DD} is maintained between 13 V and 19 V, which is higher than UVLO, for 250 ms after V_{DD-ON} . SLP is disabled for an initial 15 ms to ensure successful startup in normal LED condition.

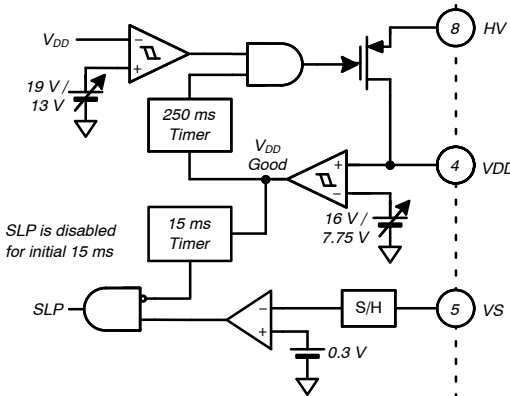

Figure 22. Internal SLP Block

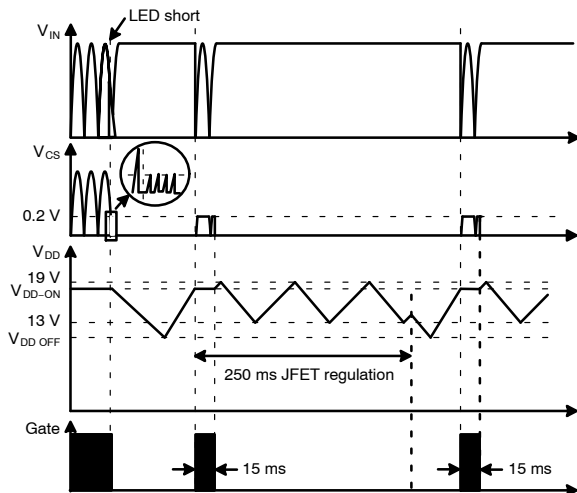

Figure 23. Waveforms in Short-LED Condition

Open-LED Protection

FL7733A protects external components, such as output diodes and output capacitors, during open-LED condition. During switch turn-off, the auxiliary winding voltage is applied as the reflected output voltage. Because the V_{DD} and V_S voltages have output voltage information through the auxiliary winding, the internal voltage comparators in the V_{DD} and V_S pins can trigger output Over-Voltage Protection (OVP), as shown in Figure 24 and Figure 25.

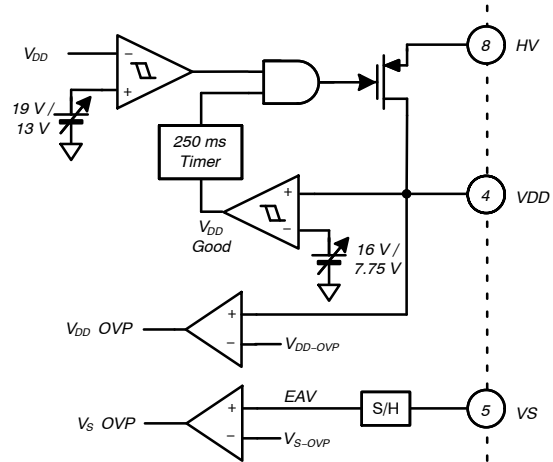

Figure 24. Internal OVP Block

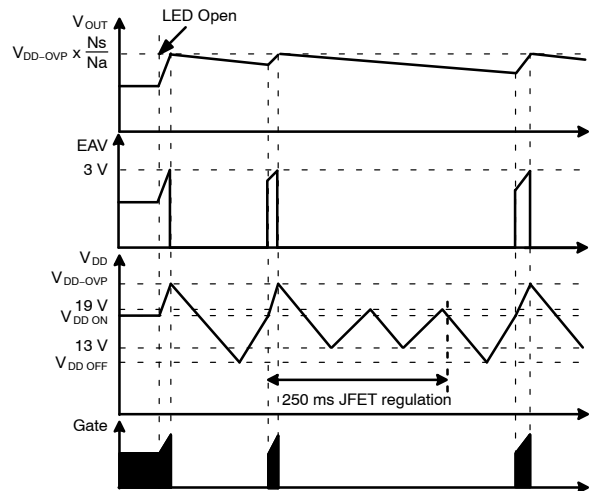

Figure 25. Waveforms in LED Open Condition

Sensing Resistor Short Protection (SRSP)

In a sensing resistor short condition, the V_{CS} level is almost zero and pulse-by-pulse current limit or OCP is not effective. The FL7733A is designed to provide sensing resistor short protection for both current and voltage mode operation. If the V_{CS} level is less than 0.1 V in the first switching cycle, the GATE output is stopped by current-mode SRSP. After 20 ms startup time, the GATE is shut down by the voltage-mode SRSP if V_{CS} level is less than 0.1 V at over 60% level of peak V_{IN} .

Under-Voltage Lockout (UVLO)

The V_{DD} turn-on and turn-off thresholds are fixed internally at 16 V and 7.75 V, respectively. During startup, the V_{DD} capacitor must be charged to 16 V through the high-voltage JFET to enable the FL7733A. The V_{DD} capacitor continues to supply V_{DD} until auxiliary power is delivered from the auxiliary winding of the main transformer. V_{DD} should remain higher than 7.75 V during this startup process. Therefore, the V_{DD} capacitor must be adequate to keep V_{DD} over the UVLO threshold until the auxiliary winding voltage is above 7.75 V.

Over-Current Protection (OCP)

When an output diode or secondary winding are shorted, switch current with extremely high di/dt can flow through the MOSFET even by minimum turn-on time. The

FL7733A is designed to protect the system against this excessive current. When the CS voltage across the sensing resistor is higher than 1.35 V, the OCP comparator output shuts down GATE switching.

In a sensing resistor open condition, the sensing resistor voltage can't be detected and output current is not regulated properly. If the sensing resistor is damaged open-circuit, the parasitic capacitor in the CS pin is charged by internal CS current sources. Therefore, the V_{CS} level is built up to the OCP threshold voltage and then switching is shut down immediately.

Over-Temperature Protection (OTP)

The temperature-sensing circuit shuts down PWM output if the junction temperature exceeds 150°C. The hysteresis temperature after OTP triggering is 10°C.

FL7733A

PCB LAYOUT GUIDANCE

PCB layout for a power converter is as important as circuit design because PCB layout with high parasitic inductance or resistance can lead to severe switching noise with system instability. PCB should be designed to minimize switching noise into control signals.

1. The signal ground and power ground should be separated and connected only at one position (GND pin) to avoid ground loop noise. The power ground path from the bridge diode to the sensing resistors should be short and wide.
2. Gate-driving current path (GATE – R_{GATE} – MOSFET – R_{CS} – GND) must be as short as possible.

3. Control pin components; such as C_{COM1} , C_{VS} , and R_{VS2} ; should be placed close to the assigned pin and signal ground.
4. High-voltage traces related to the drain of MOSFET and RCD snubber should be kept far way from control circuits to avoid unnecessary interference.
5. If a heat sink is used for the MOSFET, connect this heat sink to power ground.
6. The auxiliary winding ground should be connected closer to the GND pin than the control pin components' ground.

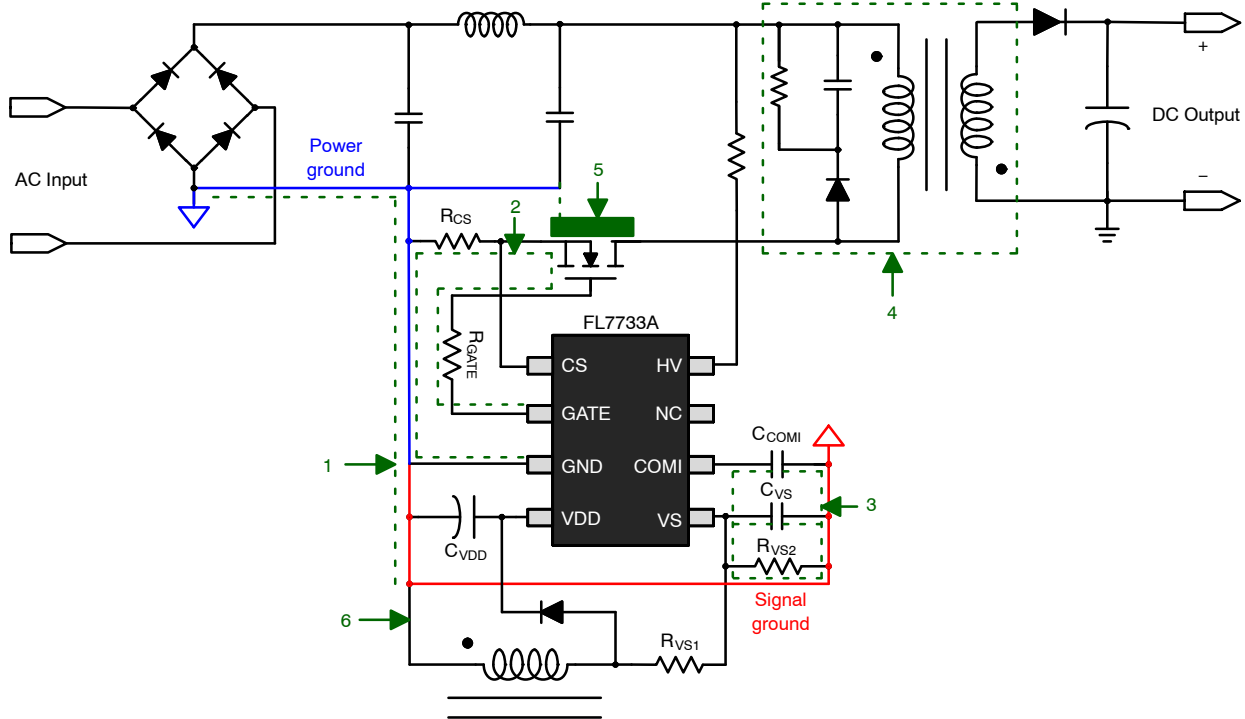

Figure 26. Layout Example

ORDERING INFORMATION

Part Number	Operating Temperature Range	Package	Shipping [†]
FL7733AMX	-40°C to +125°C	SOIC8, 8-Lead, Small Outline Package (SOP-8) (Pb-Free)	2500 / Tape & Reel

[†]For information on tape and reel specifications, including part orientation and tape sizes, please refer to our Tape and Reel Packaging Specifications Brochure, BRD8011/D.

TRUECURRENT is registered trademark of Semiconductor Components Industries, LLC dba "onsemi" or its affiliates and/or subsidiaries in the United States and/or other countries.

MECHANICAL CASE OUTLINE

PACKAGE DIMENSIONS

ON Semiconductor®



SOIC8
CASE 751EB
ISSUE A

DATE 24 AUG 2017

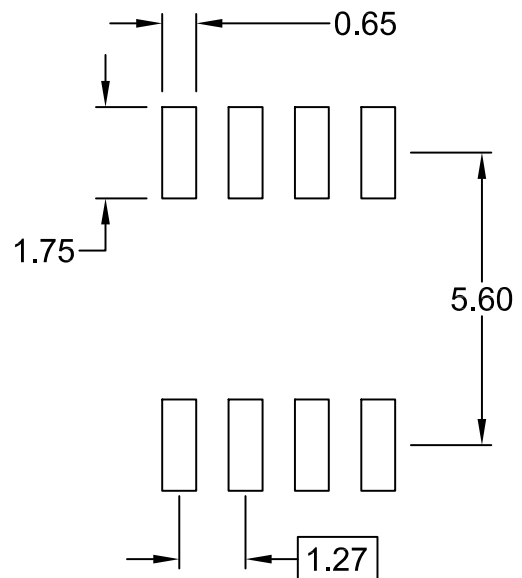
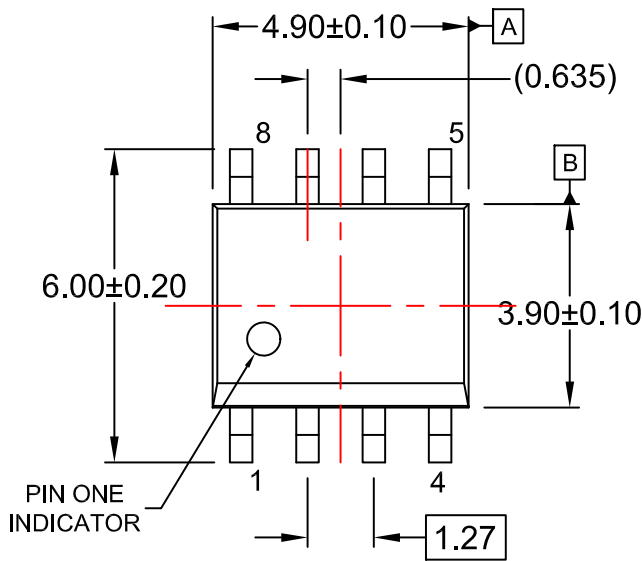

⊕ 0.25 (M) C B A

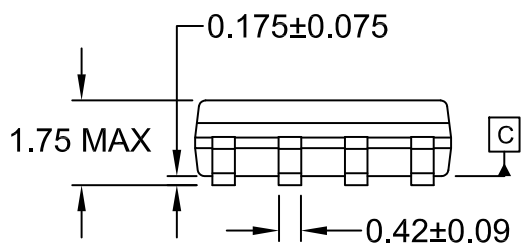

⌒ 0.10

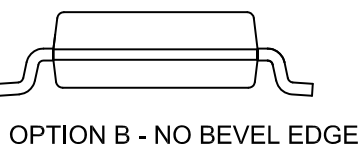
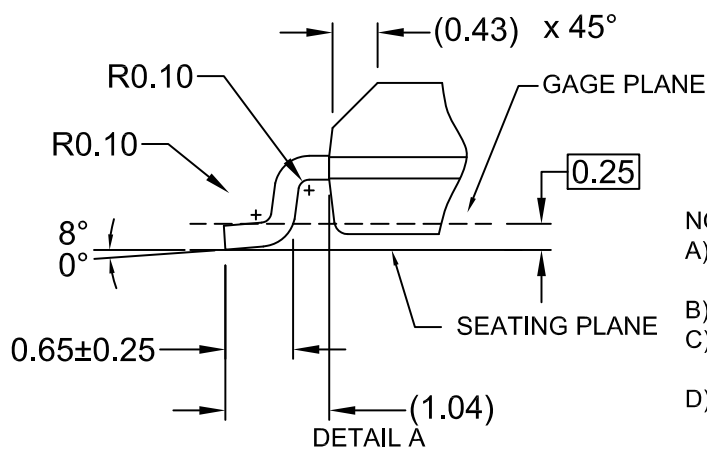
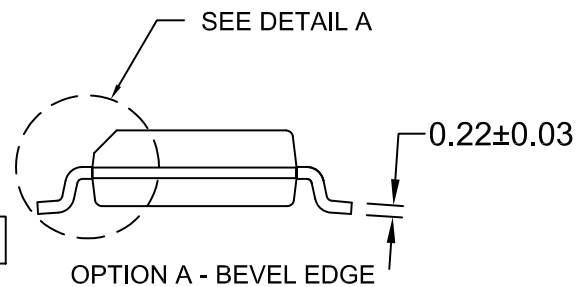

NOTES:

- A) THIS PACKAGE CONFORMS TO JEDEC MS-012, VARIATION AA.
- B) ALL DIMENSIONS ARE IN MILLIMETERS.
- C) DIMENSIONS DO NOT INCLUDE MOLD FLASH OR BURRS.
- D) LANDPATTERN STANDARD: SOIC127P600X175-8M

DOCUMENT NUMBER:	98AON13735G	Electronic versions are uncontrolled except when accessed directly from the Document Repository. Printed versions are uncontrolled except when stamped "CONTROLLED COPY" in red.
DESCRIPTION:	SOIC8	PAGE 1 OF 1

ON Semiconductor and ON are trademarks of Semiconductor Components Industries, LLC dba ON Semiconductor or its subsidiaries in the United States and/or other countries. ON Semiconductor reserves the right to make changes without further notice to any products herein. ON Semiconductor makes no warranty, representation or guarantee regarding the suitability of its products for any particular purpose, nor does ON Semiconductor assume any liability arising out of the application or use of any product or circuit, and specifically disclaims any and all liability, including without limitation special, consequential or incidental damages. ON Semiconductor does not convey any license under its patent rights nor the rights of others.

onsemi, **Onsemi**, and other names, marks, and brands are registered and/or common law trademarks of Semiconductor Components Industries, LLC dba "**onsemi**" or its affiliates and/or subsidiaries in the United States and/or other countries. **onsemi** owns the rights to a number of patents, trademarks, copyrights, trade secrets, and other intellectual property. A listing of **onsemi**'s product/patent coverage may be accessed at www.onsemi.com/site/pdf/Patent-Marking.pdf. **onsemi** reserves the right to make changes at any time to any products or information herein, without notice. The information herein is provided "as-is" and **onsemi** makes no warranty, representation or guarantee regarding the accuracy of the information, product features, availability, functionality, or suitability of its products for any particular purpose, nor does **onsemi** assume any liability arising out of the application or use of any product or circuit, and specifically disclaims any and all liability, including without limitation special, consequential or incidental damages. Buyer is responsible for its products and applications using **onsemi** products, including compliance with all laws, regulations and safety requirements or standards, regardless of any support or applications information provided by **onsemi**. "Typical" parameters which may be provided in **onsemi** data sheets and/or specifications can and do vary in different applications and actual performance may vary over time. All operating parameters, including "Typicals" must be validated for each customer application by customer's technical experts. **onsemi** does not convey any license under any of its intellectual property rights nor the rights of others. **onsemi** products are not designed, intended, or authorized for use as a critical component in life support systems or any FDA Class 3 medical devices or medical devices with a same or similar classification in a foreign jurisdiction or any devices intended for implantation in the human body. Should Buyer purchase or use **onsemi** products for any such unintended or unauthorized application, Buyer shall indemnify and hold **onsemi** and its officers, employees, subsidiaries, affiliates, and distributors harmless against all claims, costs, damages, and expenses, and reasonable attorney fees arising out of, directly or indirectly, any claim of personal injury or death associated with such unintended or unauthorized use, even if such claim alleges that **onsemi** was negligent regarding the design or manufacture of the part. **onsemi** is an Equal Opportunity/Affirmative Action Employer. This literature is subject to all applicable copyright laws and is not for resale in any manner.

PUBLICATION ORDERING INFORMATION

LITERATURE FULFILLMENT:

Email Requests to: orderlit@onsemi.com

onsemi Website: www.onsemi.com

TECHNICAL SUPPORT

North American Technical Support:

Voice Mail: 1 800-282-9855 Toll Free USA/Canada

Phone: 011 421 33 790 2910

Europe, Middle East and Africa Technical Support:

Phone: 00421 33 790 2910

For additional information, please contact your local Sales Representative

X-ON Electronics

Largest Supplier of Electrical and Electronic Components

Click to view similar products for [LED Lighting Drivers](#) category:

Click to view products by [ON Semiconductor](#) manufacturer:

Other Similar products are found below :

[LV5235V-MPB-H](#) [MB39C602PNF-G-JNEFE1](#) [MIC2871YMK-T5](#) [AL1676-10BS7-13](#) [AL1676-20AS7-13](#) [AP5726WUG-7](#) [ICL8201](#)
[IS31BL3228B-UTLS2-TR](#) [IS31BL3506B-TTLS2-TR](#) [AL3157F-7](#) [LV52204MTTBG](#) [AP5725WUG-7](#) [STP4CMPQTR](#) [NCL30086BDR2G](#)
[CAT4004BHU2-GT3](#) [LV52207AXA-VH](#) [AP1694AS-13](#) [TLE4242EJ](#) [AS3688](#) [IS31LT3172-GRLS4-TR](#) [TLD2311EL](#) [KTD2694EDQ-TR](#)
[KTZ8864EJAA-TR](#) [IS32LT3174-GRLA3-TR](#) [MP2488DN-LF-Z](#) [NLM0010XTSA1](#) [AL1676-20BS7-13](#) [ZXLD1370QESTTC](#) [MPQ7220GF-](#)
[AEC1-P](#) [MPQ7220GR-AEC1-P](#) [MPQ4425BGJ-AEC1-P](#) [MPQ7220GF-AEC1-Z](#) [MPQ7220GR-AEC1-Z](#) [MPQ4425BGJ-AEC1-Z](#)
[IS31FL3737B-QFLS4-TR](#) [IS31FL3239-QFLS4-TR](#) [KTD2058EUAC-TR](#) [KTD2037EWE-TR](#) [DIO5662ST6](#) [IS31BL3508A-TTLS2-TR](#)
[KTD2026BEWE-TR](#) [MAX20052CATC/V+](#) [MAX25606AUP/V+](#) [BD6586MUV-E2](#) [BD9206EFV-E2](#) [BD9416FS-E2](#) [LYT4227E](#)
[LYT6079C-TL](#) [MP3394SGF-P](#) [MP4689AGN-P](#)