



Is Now Part of



**ON Semiconductor®**

To learn more about ON Semiconductor, please visit our website at  
[www.onsemi.com](http://www.onsemi.com)

Please note: As part of the Fairchild Semiconductor integration, some of the Fairchild orderable part numbers will need to change in order to meet ON Semiconductor's system requirements. Since the ON Semiconductor product management systems do not have the ability to manage part nomenclature that utilizes an underscore (\_), the underscore (\_) in the Fairchild part numbers will be changed to a dash (-). This document may contain device numbers with an underscore (\_). Please check the ON Semiconductor website to verify the updated device numbers. The most current and up-to-date ordering information can be found at [www.onsemi.com](http://www.onsemi.com). Please email any questions regarding the system integration to [Fairchild\\_questions@onsemi.com](mailto:Fairchild_questions@onsemi.com).

ON Semiconductor and the ON Semiconductor logo are trademarks of Semiconductor Components Industries, LLC dba ON Semiconductor or its subsidiaries in the United States and/or other countries. ON Semiconductor owns the rights to a number of patents, trademarks, copyrights, trade secrets, and other intellectual property. A listing of ON Semiconductor's product/patent coverage may be accessed at [www.onsemi.com/site/pdf/Patent-Marking.pdf](http://www.onsemi.com/site/pdf/Patent-Marking.pdf). ON Semiconductor reserves the right to make changes without further notice to any products herein. ON Semiconductor makes no warranty, representation or guarantee regarding the suitability of its products for any particular purpose, nor does ON Semiconductor assume any liability arising out of the application or use of any product or circuit, and specifically disclaims any and all liability, including without limitation special, consequential or incidental damages. Buyer is responsible for its products and applications using ON Semiconductor products, including compliance with all laws, regulations and safety requirements or standards, regardless of any support or applications information provided by ON Semiconductor. "Typical" parameters which may be provided in ON Semiconductor data sheets and/or specifications can and do vary in different applications and actual performance may vary over time. All operating parameters, including "Typicals" must be validated for each customer application by customer's technical experts. ON Semiconductor does not convey any license under its patent rights nor the rights of others. ON Semiconductor products are not designed, intended, or authorized for use as a critical component in life support systems or any FDA Class 3 medical devices or medical devices with a same or similar classification in a foreign jurisdiction or any devices intended for implantation in the human body. Should Buyer purchase or use ON Semiconductor products for any such unintended or unauthorized application, Buyer shall indemnify and hold ON Semiconductor and its officers, employees, subsidiaries, affiliates, and distributors harmless against all claims, costs, damages, and expenses, and reasonable attorney fees arising out of, directly or indirectly, any claim of personal injury or death associated with such unintended or unauthorized use, even if such claim alleges that ON Semiconductor was negligent regarding the design or manufacture of the part. ON Semiconductor is an Equal Opportunity/Affirmative Action Employer. This literature is subject to all applicable copyright laws and is not for resale in any manner.

# FPAB30BH60B

## PFC SPM<sup>®</sup> 3 Series for Single-Phase Boost PFC

### Features

- UL Certified No. E209204 (UL1557)
- 600 V - 30 A Single-Phase Boost PFC with Integral Gate Driver and Protection
- Very Low Thermal Resistance Using Al<sub>2</sub>O<sub>3</sub> DBC Substrate
- Full-Wave Bridge Rectifier and High-Performance Output Diode
- Built-in NTC Thermistor for Temperature Monitoring
- Optimized for 20kHz Switching Frequency
- Isolation Rating: 2500 Vrms/min.

### Applications

- Single-Phase Boost PFC Converter

### Related Source

- [AN-9090 - PFC SPM 3 Series User's Guide](#)
- [AN-9091 - Boost PFC Inductor Design Guide](#)

### General Description

The FPAB30BH60B is an advanced PFC SPM<sup>®</sup> 3 module providing a fully-featured, high-performance Boost PFC (Power Factor Correction) input power stage for consumer, medical, and industrial applications. These single-phase modules integrate optimized gate drive of the built-in IGBT to minimize EMI and losses, while also providing multiple on-module protection features including under-voltage lockout, over-current shutdown, thermal monitoring, and fault reporting. These modules also feature a full-wave rectifier, and high-performance output diode for additional space savings and mounting convenience.

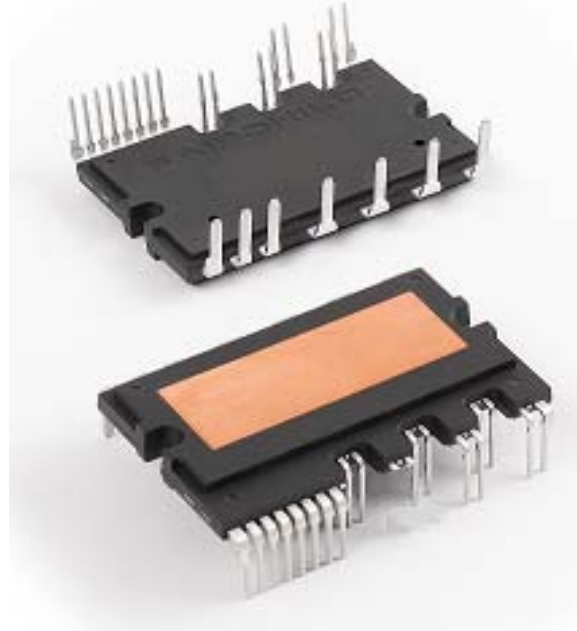

Figure 1. Package Overview

### Package Marking & Ordering Information

Device	Device Marking	Package	Packing Type	Quantity
FPAB30BH60B	FPAB30BH60B	SPMIC-027	Rail	10

## Integrated Power Functions

- PFC converter for single-phase AC / DC power conversion (please refer to Figure 3)

## Integrated Drive, Protection, and System Control Functions

- For IGBTs: gate drive circuit, Over-Current Protection (OCP), control supply circuit Under-Voltage Lock-Out (UVLO) Protection
- Fault signal: corresponding to OC and UV fault
- Built-in thermistor: temperature monitoring
- Input interface: active-HIGH interface, works with 3.3 / 5 V logic, Schmitt-trigger input

## Pin Configuration

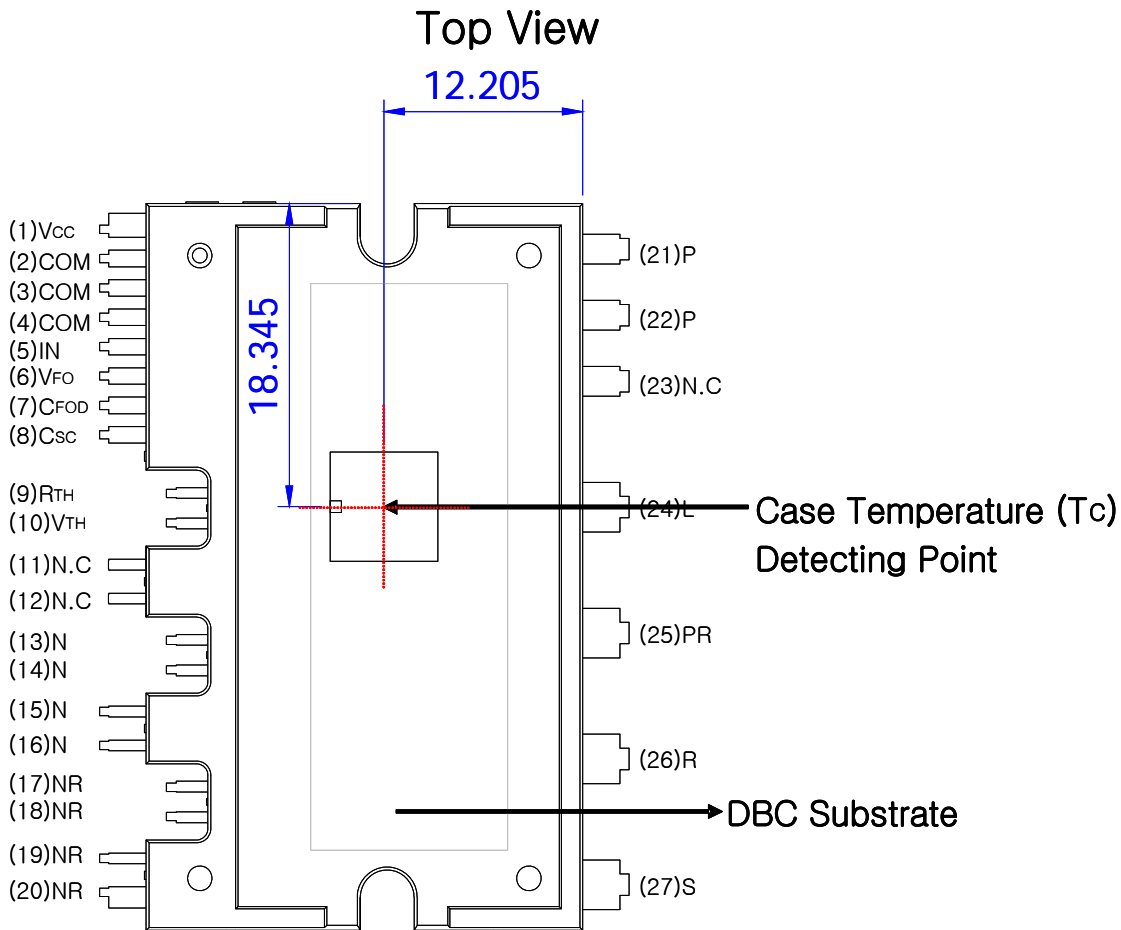

Figure 2. Top View

### Notes :

1. For the measurement point of case temperature(T<sub>c</sub>), please refer to Figure 2.

## Pin Descriptions

Pin Number	Pin Name	Pin Description
1	V <sub>CC</sub>	Common Bias Voltage for IC and IGBT Driving
2,3,4	COM	Common Supply Ground
5	IN	Signal Input for IGBT
6	V <sub>FO</sub>	Fault Output
7	C <sub>FOD</sub>	Capacitor for Fault Output Duration Selection
8	C <sub>SC</sub>	Capacitor (Low-Pass Filter) for Over-Current Detection
9	R <sub>(TH)</sub>	Series Resistor for The Use of Thermistor
10	V <sub>(TH)</sub>	Thermistor Bias Voltage
11,12	N.C	No Connection*
13~16	N	IGBT Emitter
17~20	N <sub>R</sub>	Negative DC-Link of Rectifier
21,22	P	Positive Rail of DC-Link
23	N.C	No Connection
24	L	Reactor Connection Pin
25	P <sub>R</sub>	Positive DC-Link of Rectifier
26	R	AC Input for R-Phase
27	S	AC Input for S-Phase

\* 11th and 12th pins are cut. Please refer to package outline drawings for more detail.

## Internal Equivalent Circuit and Input/Output Pins

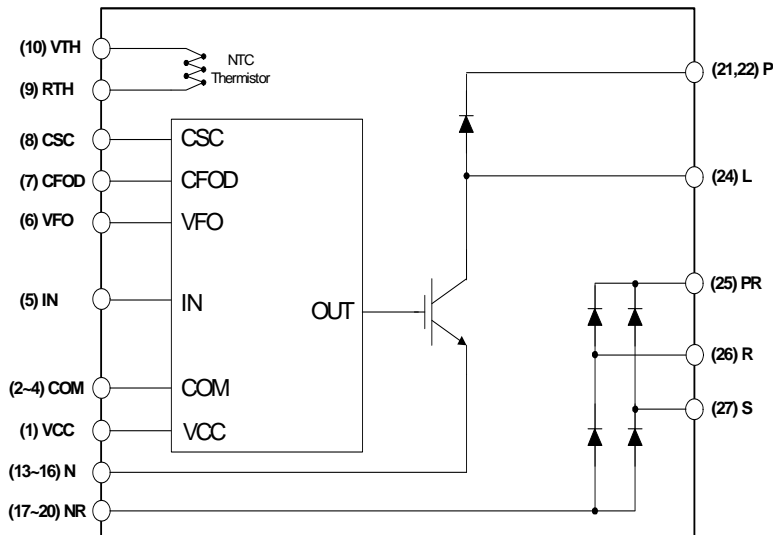

Figure 3. Internal Block Diagram

**Absolute Maximum Ratings** ( $T_J = 25^\circ\text{C}$ , unless otherwise specified.)**Converter Part**

Symbol	Item	Condition	Rating	Unit
$V_i$	Supply Voltage	Applied between R - S	264	$V_{rms}$
$V_{i(Surge)}$	Supply Voltage (Surge)	Applied between R - S	500	V
$V_{PN}$	Output Voltage	Applied between P - N	450	V
$V_{PN(Surge)}$	Output Voltage (Surge)	Applied between P - N	500	V
$V_{CES}$	Collector - Emitter Voltage		600	V
$I_C$	Each IGBT Collector Current	$T_C = 25^\circ\text{C}$ , $T_J < 150^\circ\text{C}$	30	A
$I_{CP}$	Each IGBT Collector Current (Peak)	$T_C = 25^\circ\text{C}$ , $T_J < 150^\circ\text{C}$ , Under 1ms Pulse Width	60	A
$P_C$	Collector Dissipation	$T_C = 25^\circ\text{C}$	104	W
$V_{RRM}$	Repetitive Peak Reverse Voltage		600	V
$I_{FSM}$	Peak Forward Surge Current	Single Half Sine-Wave	350	A
$T_J$	Operating Junction Temperature		-40 ~ 150	$^\circ\text{C}$

**Control Part**

Symbol	Item	Condition	Rating	Unit
$V_{CC}$	Control Supply Voltage	Applied between $V_{CC}$ - COM	20	V
$V_{IN}$	Input Signal Voltage	Applied between IN - COM	-0.3 ~ $V_{CC}+0.3$	V
$V_{FO}$	Fault Output Supply Voltage	Applied between $V_{FO}$ - COM	-0.3 ~ $V_{CC}+0.3$	V
$I_{FO}$	Fault Output Current	Sink Current at $V_{FO}$ Pin	5	mA
$V_{SC}$	Current Sensing Input Voltage	Applied between $C_{SC}$ - COM	-0.3 ~ $V_{CC}+0.3$	V

**Total System**

Symbol	Item	Condition	Rating	Unit
$T_{STG}$	Storage Temperature		-40 ~ 125	$^\circ\text{C}$
$V_{ISO}$	Isolation Voltage	60 Hz, Sinusoidal, AC 1 Minute, Connect Pins to Heat Sink Plate	2500	$V_{rms}$

**Thermal Resistance**

Symbol	Item	Condition	Min.	Typ.	Max.	Unit
$R_{\theta(j-c)Q}$	Junction to Case Thermal Resistance	IGBT	-	-	1.2	$^\circ\text{C/W}$
$R_{\theta(j-c)F}$		FRD	-	-	1.4	$^\circ\text{C/W}$
$R_{\theta(j-c)R}$		Rectifier (per 1 / 4 module)	-	-	1.7	$^\circ\text{C/W}$

## Electrical Characteristics ( $T_J = 25^\circ\text{C}$ , unless otherwise specified.)

### Converter Part

Symbol	Item	Condition	Min.	Typ.	Max.	Unit
$V_{CE(SAT)}$	IGBT Saturation Voltage	$V_{CC} = 15\text{ V}$ , $V_{IN} = 5\text{ V}$ , $I_C = 30\text{ A}$	-	2.2	2.8	V
$V_{FF}$	FRD Forward Voltage	$I_F = 30\text{ A}$	-	1.9	2.6	V
$V_{FR}$	Rectifier Forward Voltage	$I_F = 30\text{ A}$	-	1.2	1.5	V
$t_{ON}$	Switching Times	$V_{PN} = 400\text{ V}$ , $V_{CC} = 15\text{ V}$ , $I_C = 30\text{ A}$ $V_{IN} = 0\text{ V} \leftrightarrow 5\text{ V}$ , Inductive Load  (Note 2)	-	500	-	ns
$t_{C(ON)}$			-	200	-	ns
$t_{OFF}$			-	420	-	ns
$t_{C(OFF)}$			-	100	-	ns
$t_{rr}$			-	60	-	ns
$I_{rr}$			-	7	-	A
$I_{CES}$			Collector - Emitter Leakage Current	$V_{CE} = V_{CES}$	-	-

**Notes:**

2.  $t_{ON}$  and  $t_{OFF}$  include the propagation delay of the internal drive IC.  $t_{C(ON)}$  and  $t_{C(OFF)}$  are the switching time of IGBT itself under the given gate driving condition internally. For the detailed information, please see Figure 4.

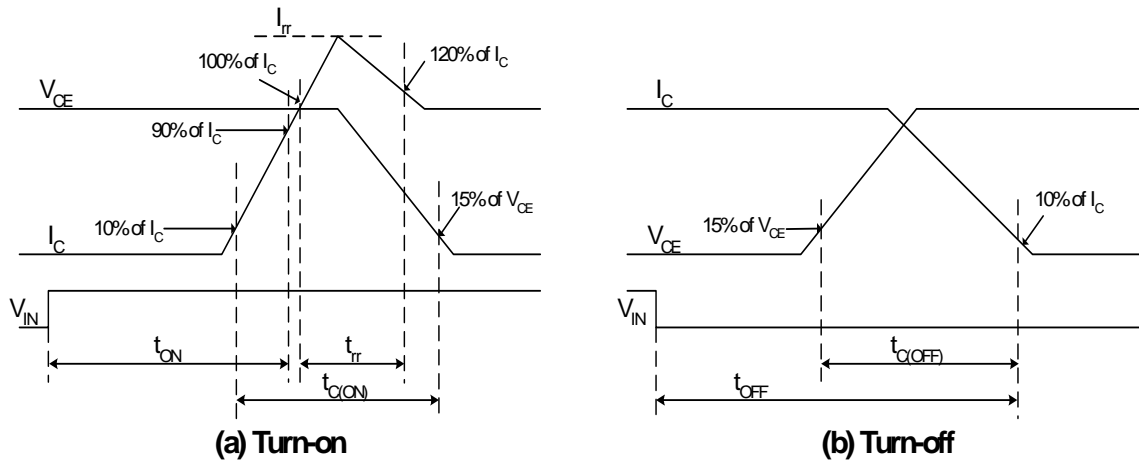

Figure 4. Switching Time Definition

**Control Part**

Symbol	Item	Condition	Min.	Typ.	Max.	Unit
I <sub>QCCL</sub>	Quiescent V <sub>CC</sub> Supply Current	V <sub>CC</sub> = 15 V, IN = 0 V   V <sub>CC</sub> - COM	-	-	26	mA
V <sub>FOH</sub>	Fault Output Voltage	V <sub>SC</sub> = 0 V, V <sub>FO</sub> Circuit: 4.7 kΩ to 5 V Pull-up	4.5	-	-	V
V <sub>FOL</sub>		V <sub>SC</sub> = 1 V, V <sub>FO</sub> Circuit: 4.7 kΩ to 5 V Pull-up	-	-	0.8	V
V <sub>SC(ref)</sub>	Over-Current Trip Level	V <sub>CC</sub> = 15 V	0.45	0.50	0.55	V
UV <sub>CCD</sub>	Supply Circuit Under-Voltage Protection	Detection Level	10.7	11.9	13.0	V
UV <sub>CCR</sub>		Reset Level	11.2	12.4	13.2	V
t <sub>FOD</sub>	Fault-Out Pulse Width	C <sub>FOD</sub> = 33 nF (Note 3)	1.4	1.8	2.0	ms
V <sub>IN(ON)</sub>	ON Threshold Voltage	Applied between IN - COM	2.8	-	-	V
V <sub>IN(OFF)</sub>	OFF Threshold Voltage		-	-	0.8	V
R <sub>TH</sub>	Resistance of Thermistor	at T <sub>TH</sub> = 25°C (Note 4, Figure 5)	-	47.0	-	kΩ
		at T <sub>TH</sub> = 100°C (Note 4, Figure 5)	-	2.9	-	kΩ

**Notes:**

- 3. The fault-out pulse width t<sub>FOD</sub> depends on the capacitance value of C<sub>FOD</sub> according to the following approximate equation: C<sub>FOD</sub> = 18.3 × 10<sup>-6</sup> × t<sub>FOD</sub> [F].
- 4. T<sub>TH</sub> is the temperature of know case temperature(T<sub>C</sub>), please make the experiment considering your application.

**R-T Curve**

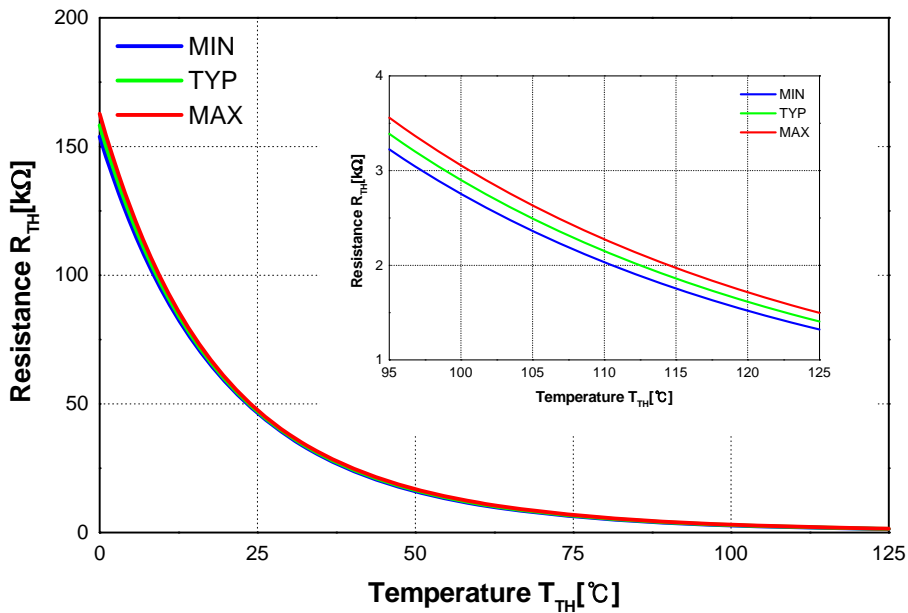

**Figure 5. R-T Curve of the Built-In Thermistor**

## Recommended Operating Condition

Symbol	Item	Condition	Min.	Typ.	Max.	Unit
$V_i$	Input Supply Voltage	Applied between R - S	187	220	253	$V_{rms}$
$V_{PN}$	Output Voltage	Applied between P - N	-	380	400	V
$V_{CC}$	Control Supply Voltage	Applied between $V_{CC(L)}$ - COM	13.5	15.0	16.5	V
$dV_{CC}/dt$	Control Supply Variation		-1	-	1	$V/\mu s$
$f_{PWM}$	PWM Input Frequency	$T_J \leq 150^\circ C$	-	20	-	kHz
$I_i$	Allowable Input Current	$T_C < 90^\circ C$ , $V_i = 220 V$ , $V_{PN} = 380 V$ $V_{PWM} = 20 kHz$	-	-	30	$A_{peak}$

## Mechanical Characteristics and Ratings

Item	Condition		Min.	Typ.	Max.	Unit
Mounting Torque	Mounting Screw: M3	Recommended 0.62 N•m	0.51	0.62	0.72	N•m
Device Flatness	See Figure 6		0	-	+120	$\mu m$
Weight			-	15.00	-	g

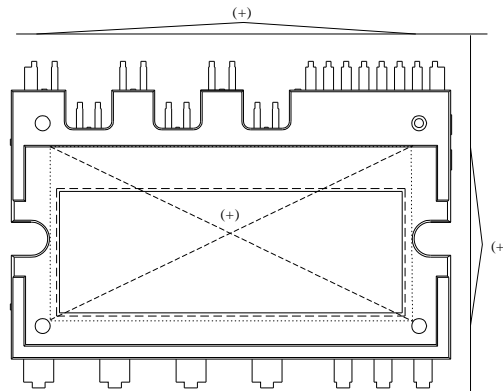
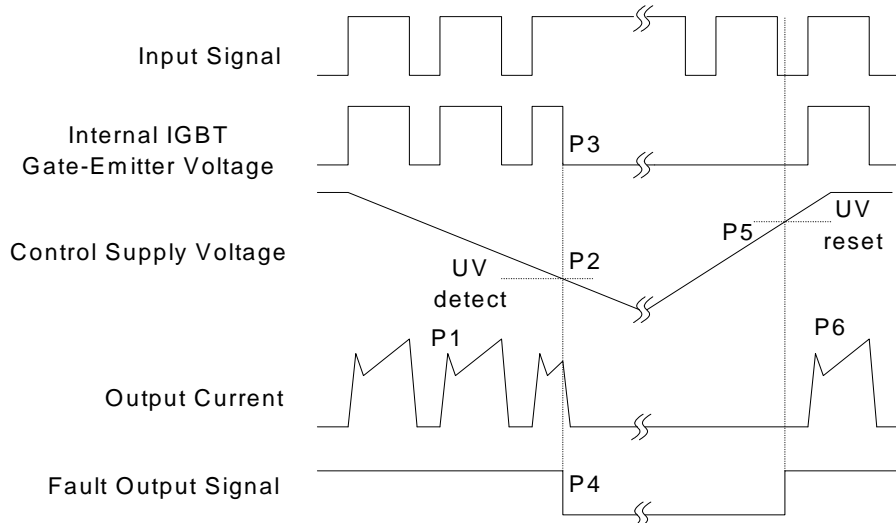

Figure 6. Flatness Measurement Position



### Time Charts of Protective Function



- P1 : Normal operation: IGBT ON and conducting current.
- P2 : Under-voltage detection.
- P3 : IGBT gate interrupt.
- P4 : Fault signal generation.
- P5 : Under-voltage reset.
- P6 : Normal operation: IGBT ON and conducting current.

**Figure 7. Under-Voltage Protection**

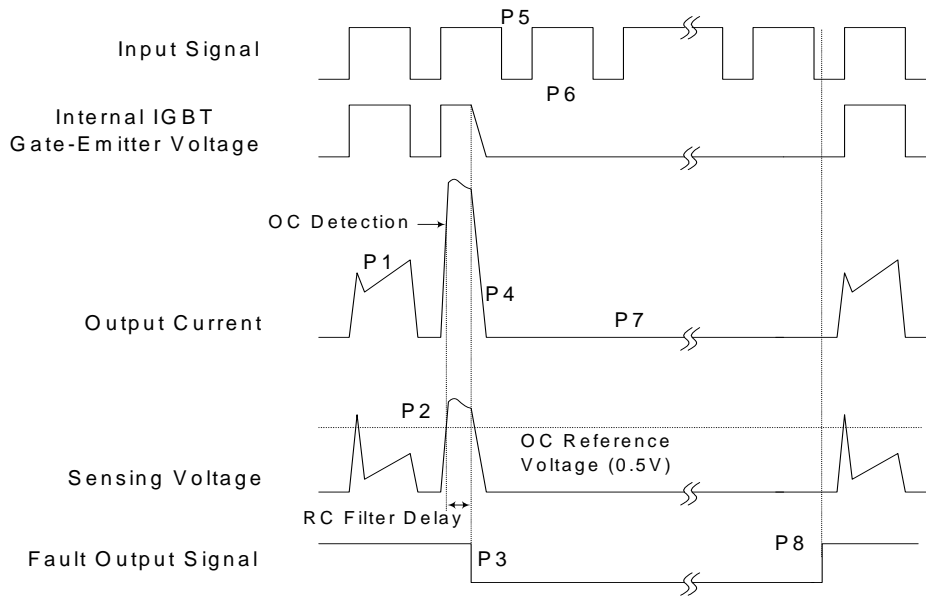

- P1 : Normal operation: IGBT ON and conducting current.
- P2 : Over current detection.
- P3 : IGBT gate interrupt / fault signal generation.
- P4 : IGBT is slowly turned off.
- P5 : IGBT OFF signal.
- P6 : IGBT ON signa: but IGBT cannot be turned on during the fault output activation.
- P7 : IGBT OFF state.
- P8 : Fault output reset and normal operation start.

**Figure 8. Over-Current Protection**

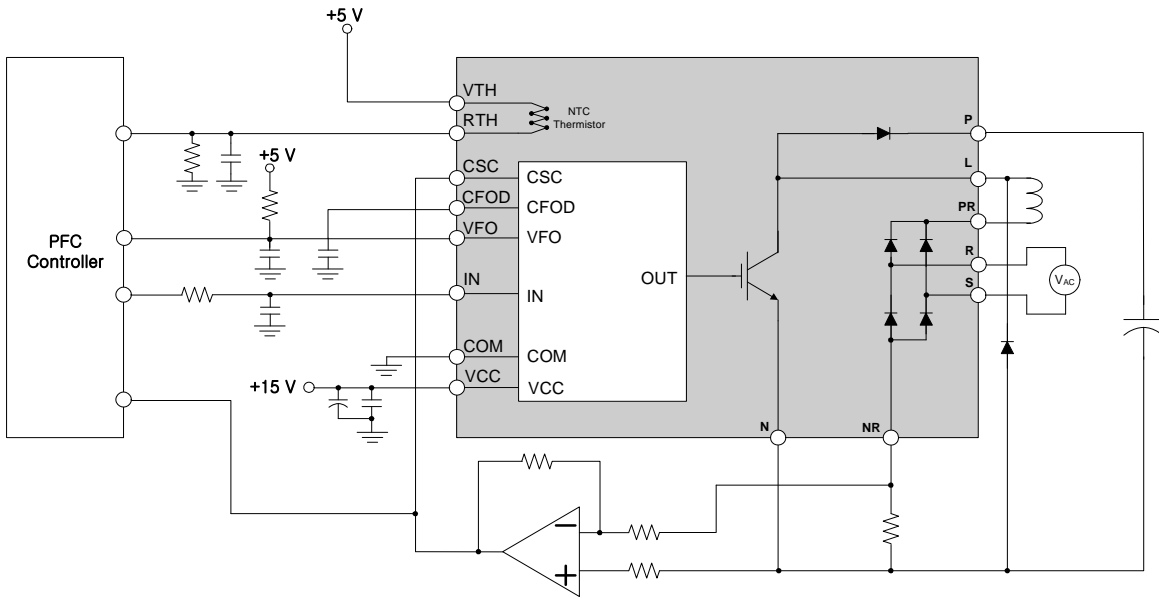
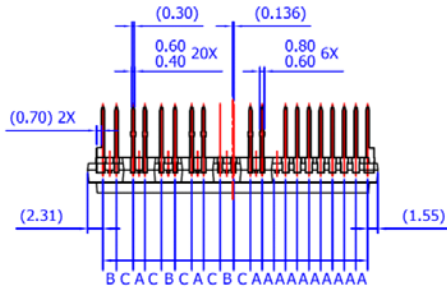

Figure 9. Application Example

Notes:

5. Each capacitors should be located as close to PFC SPM® product pins as possible.
6. It's recommended that anti-parallel diode should be connected with IGBT.

### Detailed Package Outline Drawings



LEAD PITCH (TOLERANCE : ±0.30)  
 A : 1.778  
 B : 2.050  
 C : 2.531

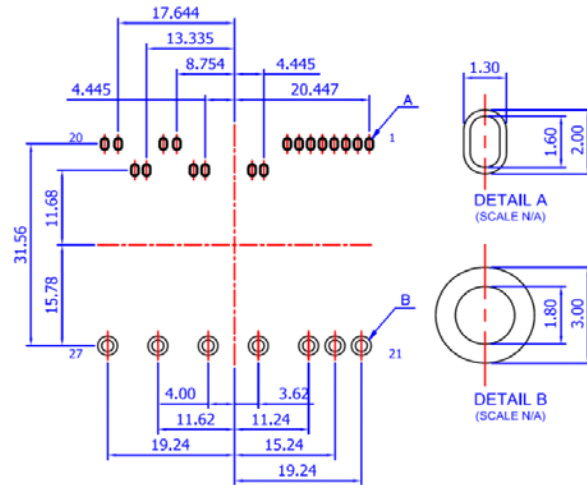
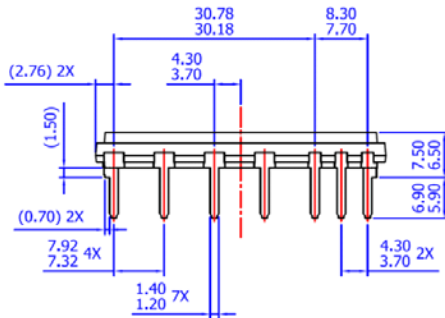
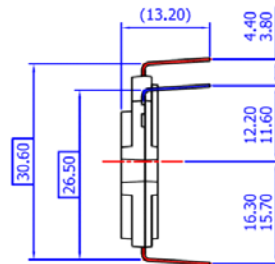
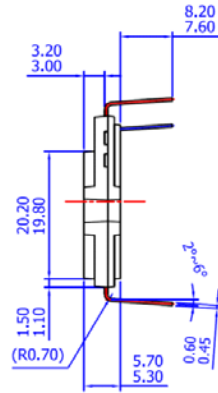
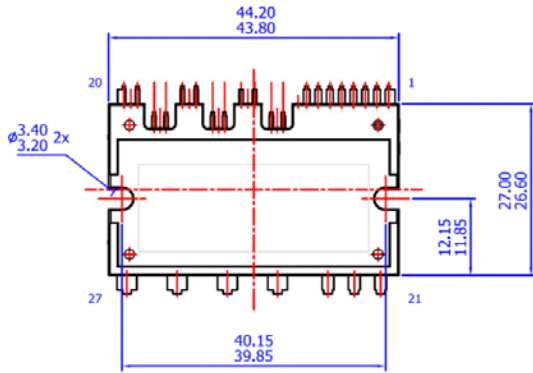

LAND PATTERN RECOMMENDATIONS

- NOTES: UNLESS OTHERWISE SPECIFIED  
 A) THIS PACKAGE DOES NOT COMPLY TO ANY CURRENT PACKAGING STANDARD  
 B) ALL DIMENSIONS ARE IN MILLIMETERS  
 C) DIMENSIONS ARE EXCLUSIVE OF BURRS, MOLD FLASH, AND TIE BAR EXTRUSIONS  
 D) ( ) IS REFERENCE  
 E) [ ] IS ASS'Y QUALITY  
 F) DRAWING FILENAME: MOD27BEREV2.0  
 G) FAIRCHILD SEMICONDUCTOR





Package drawings are provided as a service to customers considering Fairchild components. Drawings may change in any manner without notice. Please note the revision and/or data on the drawing and contact a FairchildSemiconductor representative to verify or obtain the most recent revision. Package specifications do not expand the terms of Fairchild's worldwide therm and conditions, specifically the the warranty therein, which covers Fairchild products.

Always visit Fairchild Semiconductor's online packaging area for the most recent package drawings:

<http://www.fairchildsemi.com/dwg/MO/MOD27BE.pdf>

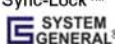
**TRADEMARKS**

The following includes registered and unregistered trademarks and service marks, owned by Fairchild Semiconductor and/or its global subsidiaries, and is not intended to be an exhaustive list of all such trademarks.

AccuPower™	F-PFS™		Sync-Lock™
AX-CAP®*	FRFET®	PowerTrench®	 SYSTEM GENERAL®
BitSiC™	Global Power Resource™	PowerXS™	TinyBoost®
Build it Now™	GreenBridge™	Programmable Active Droop™	TinyBuck®
CorePLUS™	Green FPS™	QFET®	TinyCalc™
CorePOWER™	Green FPS™ e-Series™	QS™	TinyLogic®
CROSSVOLT™	Gmax™	Quiet Series™	TINYOPTO™
CTL™	GTO™	RapidConfigure™	TinyPower™
Current Transfer Logic™	IntelliMAX™		TinyPWM™
DEUXPEED®	ISOPLANAR™	Saving our world, 1mW/W/kW at a time™	TinyWire™
Dual Cool™	Making Small Speakers Sound Louder and Better™	SignalWise™	TranSiC™
EcoSPARK®	MegaBuck™	SmartMax™	TriFault Detect™
EfficientMax™	MICROCOUPLER™	SMART START™	TRUECURRENT®*
ESBC™	MicroFET™	Solutions for Your Success™	µSerDes™
	MicroPak™	SPM®	 SerDes™
Fairchild®	MicroPak2™	STEALTH™	UHC®
Fairchild Semiconductor®	MillerDrive™	SuperFET®	Ultra FRFET™
FACT Quiet Series™	MotionMax™	SuperSOT™-3	UniFET™
FACT®	mWSaver®	SuperSOT™-6	VCX™
FAST®	OptoHiT™	SuperSOT™-8	VisualMax™
FastVCore™	OPTOLOGIC®	SupreMOS®	VoltagePlus™
FETBench™	OPTOPLANAR®	SyncFET™	XS™
FPS™			

\* Trademarks of System General Corporation, used under license by Fairchild Semiconductor.

**DISCLAIMER**

FAIRCHILD SEMICONDUCTOR RESERVES THE RIGHT TO MAKE CHANGES WITHOUT FURTHER NOTICE TO ANY PRODUCTS HEREIN TO IMPROVE RELIABILITY, FUNCTION, OR DESIGN. FAIRCHILD DOES NOT ASSUME ANY LIABILITY ARISING OUT OF THE APPLICATION OR USE OF ANY PRODUCT OR CIRCUIT DESCRIBED HEREIN; NEITHER DOES IT CONVEY ANY LICENSE UNDER ITS PATENT RIGHTS, NOR THE RIGHTS OF OTHERS. THESE SPECIFICATIONS DO NOT EXPAND THE TERMS OF FAIRCHILD'S WORLDWIDE TERMS AND CONDITIONS, SPECIFICALLY THE WARRANTY THEREIN, WHICH COVERS THESE PRODUCTS.

**LIFE SUPPORT POLICY**

FAIRCHILD'S PRODUCTS ARE NOT AUTHORIZED FOR USE AS CRITICAL COMPONENTS IN LIFE SUPPORT DEVICES OR SYSTEMS WITHOUT THE EXPRESS WRITTEN APPROVAL OF FAIRCHILD SEMICONDUCTOR CORPORATION.

As used herein:

- Life support devices or systems are devices or systems which, (a) are intended for surgical implant into the body or (b) support or sustain life, and (c) whose failure to perform when properly used in accordance with instructions for use provided in the labeling, can be reasonably expected to result in a significant injury of the user.
- A critical component in any component of a life support, device, or system whose failure to perform can be reasonably expected to cause the failure of the life support device or system, or to affect its safety or effectiveness.

**ANTI-COUNTERFEITING POLICY**

Fairchild Semiconductor Corporation's Anti-Counterfeiting Policy. Fairchild's Anti-Counterfeiting Policy is also stated on our external website, [www.fairchildsemi.com](http://www.fairchildsemi.com), under Sales Support.

Counterfeiting of semiconductor parts is a growing problem in the industry. All manufacturers of semiconductor products are experiencing counterfeiting of their parts. Customers who inadvertently purchase counterfeit parts experience many problems such as loss of brand reputation, substandard performance, failed applications, and increased cost of production and manufacturing delays. Fairchild is taking strong measures to protect ourselves and our customers from the proliferation of counterfeit parts. Fairchild strongly encourages customers to purchase Fairchild parts either directly from Fairchild or from Authorized Fairchild Distributors who are listed by country on our web page cited above. Products customers buy either from Fairchild directly or from Authorized Fairchild Distributors are genuine parts, have full traceability, meet Fairchild's quality standards for handling and storage and provide access to Fairchild's full range of up-to-date technical and product information. Fairchild and our Authorized Distributors will stand behind all warranties and will appropriately address any warranty issues that may arise. Fairchild will not provide any warranty coverage or other assistance for parts bought from Unauthorized Sources. Fairchild is committed to combat this global problem and encourage our customers to do their part in stopping this practice by buying direct or from authorized distributors.

**PRODUCT STATUS DEFINITIONS**
**Definition of Terms**

Datasheet Identification	Product Status	Definition
Advance Information	Formative / In Design	Datasheet contains the design specifications for product development. Specifications may change in any manner without notice.
Preliminary	First Production	Datasheet contains preliminary data; supplementary data will be published at a later date. Fairchild Semiconductor reserves the right to make changes at any time without notice to improve design.
No Identification Needed	Full Production	Datasheet contains final specifications. Fairchild Semiconductor reserves the right to make changes at any time without notice to improve the design.
Obsolete	Not In Production	Datasheet contains specifications on a product that is discontinued by Fairchild Semiconductor. The datasheet is for reference information only.

Rev. 166

ON Semiconductor and  are trademarks of Semiconductor Components Industries, LLC dba ON Semiconductor or its subsidiaries in the United States and/or other countries. ON Semiconductor owns the rights to a number of patents, trademarks, copyrights, trade secrets, and other intellectual property. A listing of ON Semiconductor's product/patent coverage may be accessed at [www.onsemi.com/site/pdf/Patent-Marking.pdf](http://www.onsemi.com/site/pdf/Patent-Marking.pdf). ON Semiconductor reserves the right to make changes without further notice to any products herein. ON Semiconductor makes no warranty, representation or guarantee regarding the suitability of its products for any particular purpose, nor does ON Semiconductor assume any liability arising out of the application or use of any product or circuit, and specifically disclaims any and all liability, including without limitation special, consequential or incidental damages. Buyer is responsible for its products and applications using ON Semiconductor products, including compliance with all laws, regulations and safety requirements or standards, regardless of any support or applications information provided by ON Semiconductor. "Typical" parameters which may be provided in ON Semiconductor data sheets and/or specifications can and do vary in different applications and actual performance may vary over time. All operating parameters, including "Typicals" must be validated for each customer application by customer's technical experts. ON Semiconductor does not convey any license under its patent rights nor the rights of others. ON Semiconductor products are not designed, intended, or authorized for use as a critical component in life support systems or any FDA Class 3 medical devices or medical devices with a same or similar classification in a foreign jurisdiction or any devices intended for implantation in the human body. Should Buyer purchase or use ON Semiconductor products for any such unintended or unauthorized application, Buyer shall indemnify and hold ON Semiconductor and its officers, employees, subsidiaries, affiliates, and distributors harmless against all claims, costs, damages, and expenses, and reasonable attorney fees arising out of, directly or indirectly, any claim of personal injury or death associated with such unintended or unauthorized use, even if such claim alleges that ON Semiconductor was negligent regarding the design or manufacture of the part. ON Semiconductor is an Equal Opportunity/Affirmative Action Employer. This literature is subject to all applicable copyright laws and is not for resale in any manner.

## PUBLICATION ORDERING INFORMATION

### LITERATURE FULFILLMENT:

Literature Distribution Center for ON Semiconductor  
19521 E. 32nd Pkwy, Aurora, Colorado 80011 USA  
**Phone:** 303-675-2175 or 800-344-3860 Toll Free USA/Canada  
**Fax:** 303-675-2176 or 800-344-3867 Toll Free USA/Canada  
**Email:** [orderlit@onsemi.com](mailto:orderlit@onsemi.com)

**N. American Technical Support:** 800-282-9855 Toll Free  
USA/Canada  
**Europe, Middle East and Africa Technical Support:**  
Phone: 421 33 790 2910  
**Japan Customer Focus Center**  
Phone: 81-3-5817-1050

**ON Semiconductor Website:** [www.onsemi.com](http://www.onsemi.com)  
**Order Literature:** <http://www.onsemi.com/orderlit>  
For additional information, please contact your local  
Sales Representative

## X-ON Electronics

Largest Supplier of Electrical and Electronic Components

*Click to view similar products for [Motor/Motion/Ignition Controllers & Drivers](#) category:*

*Click to view products by [ON Semiconductor](#) manufacturer:*

Other Similar products are found below :

[FSB50550TB2](#) [FSBF15CH60BTH](#) [MSVCPM2-63-12](#) [MSVGW45-14-2](#) [MSVGW54-14-3](#) [MSVGW54-14-5](#) [NTE7043](#) [LA6565VR-TLM-E](#)  
[LB11650-E](#) [LB1837M-TLM-E](#) [LB1845DAZ-XE](#) [LC898300XA-MH](#) [SS30-TE-L-E](#) [26700](#) [LV8281VR-TLM-H](#) [BA5839FP-E2](#) [IRAM236-1067A](#) [LA6584JA-AH](#) [LB11847L-E](#) [NCV70501DW002R2G](#) [AH293-PL-B](#) [STK672-630CN-E](#) [TND315S-TL-2H](#) [FNA23060](#) [FSB50250AB](#)  
[FNA41060](#) [MSVB54](#) [MSVBTC50E](#) [MSVCPM3-54-12](#) [MSVCPM3-63-12](#) [MSVCPM4-63-12](#) [MSVTA120](#) [FSB50550AB](#)  
[NCV70501DW002G](#) [LC898301XA-MH](#) [LV8413GP-TE-L-E](#) [MSVGW45-14-3](#) [MSVGW45-14-4](#) [MSVGW45-14-5](#) [MSVGW54-14-4](#)  
[STK984-091A-E](#) [MP6519GQ-Z](#) [LB11651-E](#) [IRSM515-025DA4](#) [LV8127T-TLM-H](#) [MC33812EKR2](#) [NCP81382MNTXG](#) [TDA21801](#)  
[LB11851FA-BH](#) [NCV70627DQ001R2G](#)