



Is Now Part of



**ON Semiconductor®**

To learn more about ON Semiconductor, please visit our website at  
[www.onsemi.com](http://www.onsemi.com)

Please note: As part of the Fairchild Semiconductor integration, some of the Fairchild orderable part numbers will need to change in order to meet ON Semiconductor's system requirements. Since the ON Semiconductor product management systems do not have the ability to manage part nomenclature that utilizes an underscore (\_), the underscore (\_) in the Fairchild part numbers will be changed to a dash (-). This document may contain device numbers with an underscore (\_). Please check the ON Semiconductor website to verify the updated device numbers. The most current and up-to-date ordering information can be found at [www.onsemi.com](http://www.onsemi.com). Please email any questions regarding the system integration to [Fairchild\\_questions@onsemi.com](mailto:Fairchild_questions@onsemi.com).

ON Semiconductor and the ON Semiconductor logo are trademarks of Semiconductor Components Industries, LLC dba ON Semiconductor or its subsidiaries in the United States and/or other countries. ON Semiconductor owns the rights to a number of patents, trademarks, copyrights, trade secrets, and other intellectual property. A listing of ON Semiconductor's product/patent coverage may be accessed at [www.onsemi.com/site/pdf/Patent-Marking.pdf](http://www.onsemi.com/site/pdf/Patent-Marking.pdf). ON Semiconductor reserves the right to make changes without further notice to any products herein. ON Semiconductor makes no warranty, representation or guarantee regarding the suitability of its products for any particular purpose, nor does ON Semiconductor assume any liability arising out of the application or use of any product or circuit, and specifically disclaims any and all liability, including without limitation special, consequential or incidental damages. Buyer is responsible for its products and applications using ON Semiconductor products, including compliance with all laws, regulations and safety requirements or standards, regardless of any support or applications information provided by ON Semiconductor. "Typical" parameters which may be provided in ON Semiconductor data sheets and/or specifications can and do vary in different applications and actual performance may vary over time. All operating parameters, including "Typicals" must be validated for each customer application by customer's technical experts. ON Semiconductor does not convey any license under its patent rights nor the rights of others. ON Semiconductor products are not designed, intended, or authorized for use as a critical component in life support systems or any FDA Class 3 medical devices or medical devices with a same or similar classification in a foreign jurisdiction or any devices intended for implantation in the human body. Should Buyer purchase or use ON Semiconductor products for any such unintended or unauthorized application, Buyer shall indemnify and hold ON Semiconductor and its officers, employees, subsidiaries, affiliates, and distributors harmless against all claims, costs, damages, and expenses, and reasonable attorney fees arising out of, directly or indirectly, any claim of personal injury or death associated with such unintended or unauthorized use, even if such claim alleges that ON Semiconductor was negligent regarding the design or manufacture of the part. ON Semiconductor is an Equal Opportunity/Affirmative Action Employer. This literature is subject to all applicable copyright laws and is not for resale in any manner.

# FSB50450UD

## Motion SPM® 5 Series

### Features

- UL Certified No. E209204 (UL1557)
- 500 V  $R_{DS(on)} = 2.4 \Omega$ (Max) FRFET MOSFET 3-Phase Inverter with Gate Drivers and Protection
- Built-In Bootstrap Diodes Simplify PCB Layout
- Separate Open-Source Pins from Low-Side MOSFETs for Three-Phase Current-Sensing
- Active-HIGH Interface, Works with 3.3 / 5 V Logic, Schmitt-trigger Input
- Optimized for Low Electromagnetic Interference
- HVIC for Gate Driving and Under-Voltage Protection
- Isolation Rating: 1500  $V_{rms}$  / min.
- RoHS Compliant

### Applications

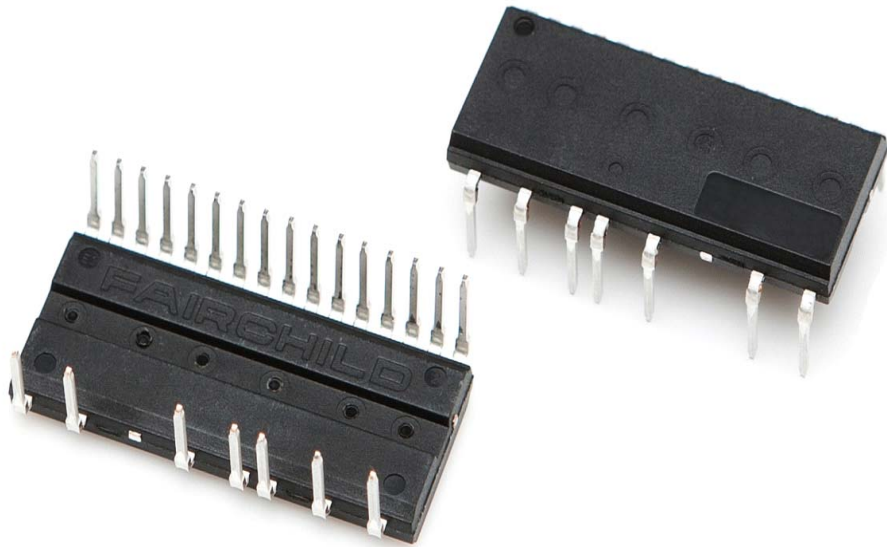
- 3-Phase Inverter Driver for Small Power AC Motor Drives

### Related Source

- [AN-9082 - Motion SPM5 Series Thermal Performance by Contact Pressure](#)

### General Description

The FSB50450UD is an advanced Motion SPM® 5 module providing a fully-featured, high-performance inverter output stage for AC Induction, BLDC and PMSM motors. These modules integrate optimized gate drive of the built-in MOSFETs (FRFET® technology) to minimize EMI and losses, while also providing multiple on-module protection features including under-voltage lockouts and thermal monitoring. The built-in high-speed HVIC requires only a single supply voltage and translates the incoming logic-level gate inputs to the high-voltage, high-current drive signals required to properly drive the module's internal MOSFETs. Separate open-source MOSFET terminals are available for each phase to support the widest variety of control algorithms.



### Package Marking & Ordering Information

Device	Device Marking	Package	Packing Type	Quantity
FSB50450UD	FSB50450UD	SPM5R-023	Rail	15

## Absolute Maximum Ratings

**Inverter Part** (each MOSFET unless otherwise specified.)

Symbol	Parameter	Conditions	Rating	Unit
$V_{DSS}$	Drain-Source Voltage of Each MOSFET		500	V
* $I_{D25}$	Each MOSFET Drain Current, Continuous	$T_C = 25^\circ\text{C}$	1.5	A
* $I_{D80}$	Each MOSFET Drain Current, Continuous	$T_C = 80^\circ\text{C}$	1.1	A
* $I_{DP}$	Each MOSFET Drain Current, Peak	$T_C = 25^\circ\text{C}$ , $PW < 100 \mu\text{s}$	3.8	A
* $P_D$	Maximum Power Dissipation	$T_C = 25^\circ\text{C}$ , For Each MOSFET	14	W

**Control Part** (each HVIC unless otherwise specified.)

Symbol	Parameter	Conditions	Rating	Unit
$V_{CC}$	Control Supply Voltage	Applied Between $V_{CC}$ and COM	20	V
$V_{BS}$	High-side Bias Voltage	Applied Between $V_B$ and $V_S$	20	V
$V_{IN}$	Input Signal Voltage	Applied Between IN and COM	$-0.3 \sim V_{CC} + 0.3$	V

**Bootstrap Diode Part** (each bootstrap diode unless otherwise specified.)

Symbol	Parameter	Conditions	Rating	Unit
$V_{RRMB}$	Maximum Repetitive Reverse Voltage		500	V
* $I_{FB}$	Forward Current	$T_C = 25^\circ\text{C}$	0.5	A
* $I_{FPB}$	Forward Current (Peak)	$T_C = 25^\circ\text{C}$ , Under 1ms Pulse Width	2.0	A

### Thermal Resistance

Symbol	Parameter	Conditions	Rating	Unit
$R_{\theta JC}$	Junction to Case Thermal Resistance	Each MOSFET under Inverter Operating Condition (1st Note 1)	8.9	$^\circ\text{C}/\text{W}$

### Total System

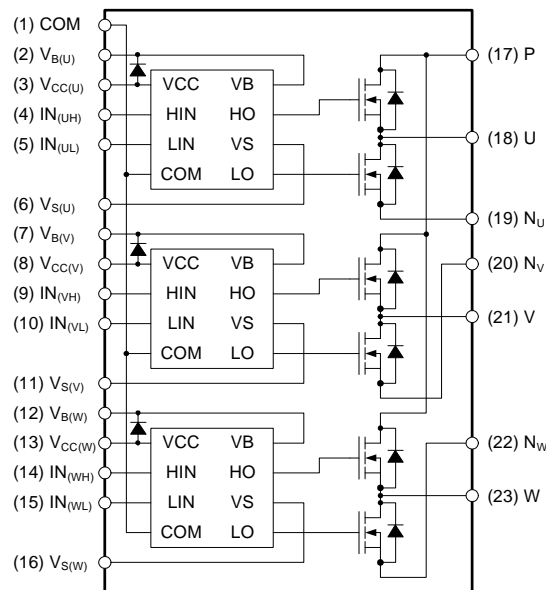
Symbol	Parameter	Conditions	Rating	Unit
$T_J$	Operating Junction Temperature		$-40 \sim 150$	$^\circ\text{C}$
$T_{STG}$	Storage Temperature		$-40 \sim 125$	$^\circ\text{C}$
$V_{ISO}$	Isolation Voltage	60 Hz, Sinusoidal, 1 Minute, Connect Pins to Heat Sink Plate	1500	$V_{rms}$

#### 1st Notes:

- For the measurement point of case temperature  $T_C$ , please refer to Figure 4.
- Marking "\*" is calculation value or design factor.

## Pin descriptions

Pin Number	Pin Name	Pin Description
1	COM	IC Common Supply Ground
2	$V_{B(U)}$	Bias Voltage for U Phase High Side MOSFET Driving
3	$V_{CC(U)}$	Bias Voltage for U Phase IC and Low Side MOSFET Driving
4	$IN_{(UH)}$	Signal Input for U Phase High-Side
5	$IN_{(UL)}$	Signal Input for U Phase Low-Side
6	$V_{S(U)}$	Bias Voltage Ground for U Phase High Side MOSFET Driving
7	$V_{B(V)}$	Bias Voltage for V Phase High Side MOSFET Driving
8	$V_{CC(V)}$	Bias Voltage for V Phase IC and Low Side MOSFET Driving
9	$IN_{(VH)}$	Signal Input for V Phase High-Side
10	$IN_{(VL)}$	Signal Input for V Phase Low-Side
11	$V_{S(V)}$	Bias Voltage Ground for V Phase High Side MOSFET Driving
12	$V_{B(W)}$	Bias Voltage for W Phase High Side MOSFET Driving
13	$V_{CC(W)}$	Bias Voltage for W Phase IC and Low Side MOSFET Driving
14	$IN_{(WH)}$	Signal Input for W Phase High-Side
15	$IN_{(WL)}$	Signal Input for W Phase Low-Side
16	$V_{S(W)}$	Bias Voltage Ground for W Phase High Side MOSFET Driving
17	P	Positive DC-Link Input
18	U	Output for U Phase
19	$N_U$	Negative DC-Link Input for U Phase
20	$N_V$	Negative DC-Link Input for V Phase
21	V	Output for V Phase
22	$N_W$	Negative DC-Link Input for W Phase
23	W	Output for W Phase



**Figure 1. Pin Configuration and Internal Block Diagram (Bottom View)**

**1st Notes:**

- Source terminal of each low-side MOSFET is not connected to supply ground or bias voltage ground inside Motion SPM® 5 product. External connections should be made as indicated in Figure 3.

## Electrical Characteristics (T<sub>J</sub> = 25°C, V<sub>CC</sub> = V<sub>BS</sub> = 15 V unless otherwise specified.)

### Inverter Part (each MOSFET unless otherwise specified.)

Symbol	Parameter	Conditions	Min	Typ	Max	Unit
BV <sub>DSS</sub>	Drain - Source Breakdown Voltage	V <sub>IN</sub> = 0 V, I <sub>D</sub> = 250 μA (2nd Note 1)	500	-	-	V
ΔBV <sub>DSS</sub> /ΔT <sub>J</sub>	Breakdown Voltage Temperature Coefficient	I <sub>D</sub> = 250μA, Referenced to 25°C	-	0.53	-	V
I <sub>DSS</sub>	Zero Gate Voltage Drain Current	V <sub>IN</sub> = 0 V, V <sub>DS</sub> = 500 V	-	-	250	μA
R <sub>DS(on)</sub>	Static Drain - Source Turn-On Resistance	V <sub>CC</sub> = V <sub>BS</sub> = 15 V, V <sub>IN</sub> = 5 V, I <sub>D</sub> = 0.5 A	-	1.9	2.4	Ω
V <sub>SD</sub>	Drain - Source Diode Forward Voltage	V <sub>CC</sub> = V <sub>BS</sub> = 15V, V <sub>IN</sub> = 0 V, I <sub>D</sub> = -0.5 A	-	-	1.2	V
t <sub>ON</sub>	Switching Times	V <sub>PN</sub> = 300 V, V <sub>CC</sub> = V <sub>BS</sub> = 15 V, I <sub>D</sub> = 0.5 A V <sub>IN</sub> = 0 V ↔ 5 V, Inductive Load L = 3 mH High- and Low-Side MOSFET Switching (2nd Note 2)	-	1250	-	ns
t <sub>OFF</sub>			-	500	-	ns
t <sub>rr</sub>			-	200	-	ns
E <sub>ON</sub>			-	80	-	μJ
E <sub>OFF</sub>			-	10	-	μJ
RBSOA			Reverse Bias Safe Operating Area	V <sub>PN</sub> = 400 V, V <sub>CC</sub> = V <sub>BS</sub> = 15 V, I <sub>D</sub> = I <sub>DP</sub> , V <sub>DS</sub> = BV <sub>DSS</sub> , T <sub>J</sub> = 150°C High- and Low-Side MOSFET Switching (2nd Note 3)	Full Square	

### Control Part (each HVIC unless otherwise specified.)

Symbol	Parameter	Conditions	Min	Typ	Max	Unit
I <sub>QCC</sub>	Quiescent V <sub>CC</sub> Current	V <sub>CC</sub> = 15 V, V <sub>IN</sub> = 0 V Applied Between V <sub>CC</sub> and COM	-	-	160	μA
I <sub>QBS</sub>	Quiescent V <sub>BS</sub> Current	V <sub>BS</sub> = 15 V, V <sub>IN</sub> = 0 V Applied Between V <sub>B(U)</sub> - U, V <sub>B(V)</sub> - V, V <sub>B(W)</sub> - W	-	-	100	μA
UV <sub>CCD</sub>	Low-Side Under-Voltage Protection (Figure 8)	V <sub>CC</sub> Under-Voltage Protection Detection Level	7.4	8.0	9.4	V
UV <sub>CCR</sub>		V <sub>CC</sub> Under-Voltage Protection Reset Level	8.0	8.9	9.8	V
UV <sub>BSD</sub>	High-Side Under-Voltage Protection (Figure 9)	V <sub>BS</sub> Under-Voltage Protection Detection Level	7.4	8.0	9.4	V
UV <sub>BSR</sub>		V <sub>BS</sub> Under-Voltage Protection Reset Level	8.0	8.9	9.8	V
V <sub>IH</sub>	ON Threshold Voltage	Logic High Level Applied between IN and COM	2.9	-	-	V
V <sub>IL</sub>	OFF Threshold Voltage	Logic Low Level	-	-	0.8	V
I <sub>IH</sub>	Input Bias Current	V <sub>IN</sub> = 5V Applied between IN and COM	-	10	20	μA
I <sub>IL</sub>		V <sub>IN</sub> = 0V	-	-	2	μA

### Bootstrap Diode Part (each bootstrap diode unless otherwise specified.)

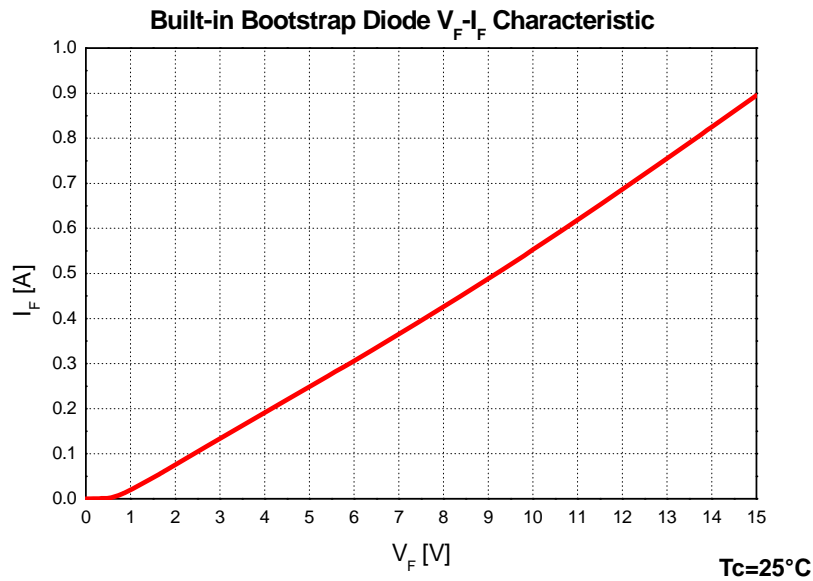
Symbol	Parameter	Conditions	Min	Typ	Max	Unit
V <sub>FB</sub>	Forward Voltage	I <sub>F</sub> = 0.1 A, T <sub>C</sub> = 25°C (2nd Note 5)	-	2.0	-	V
t <sub>rrB</sub>	Reverse Recovery Time	I <sub>F</sub> = 0.1 A, T <sub>C</sub> = 25°C	-	80	-	ns

#### 2nd Notes:

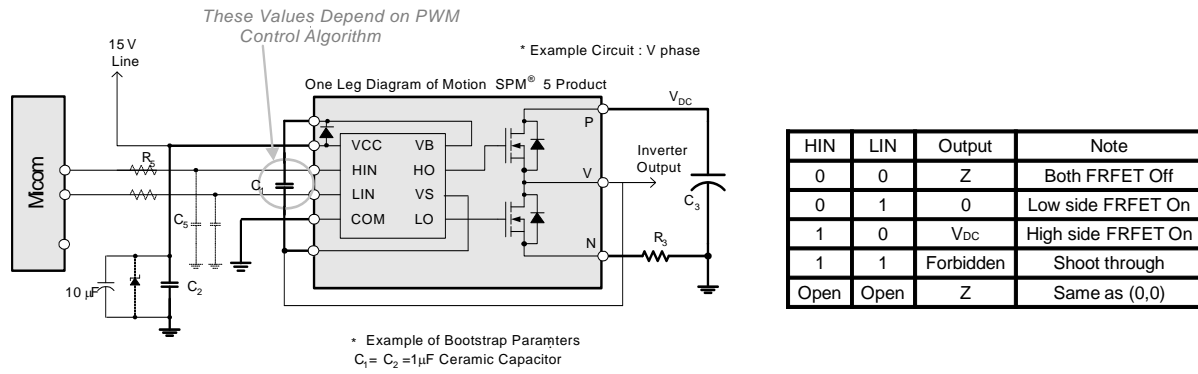
- BV<sub>DSS</sub> is the absolute maximum voltage rating between drain and source terminal of each MOSFET inside Motion SPM® 5 product. V<sub>PN</sub> should be sufficiently less than this value considering the effect of the stray inductance so that V<sub>PN</sub> should not exceed BV<sub>DSS</sub> in any case.
- t<sub>ON</sub> and t<sub>OFF</sub> include the propagation delay of the internal drive IC. Listed values are measured at the laboratory test condition, and they can be different according to the field applications due to the effect of different printed circuit boards and wirings. Please see Figure 5 for the switching time definition with the switching test circuit of Figure 6.
- The peak current and voltage of each MOSFET during the switching operation should be included in the Safe Operating Area (SOA). Please see Figure 6 for the RBSOA test circuit that is same as the switching test circuit.
- Built-in bootstrap diode includes around 15 Ω resistance characteristic. Please refer to Figure 2.

### Recommended Operating Condition

Symbol	Parameter	Conditions	Min.	Typ.	Max.	Unit
$V_{PN}$	Supply Voltage	Applied Between P and N	-	300	400	V
$V_{CC}$	Control Supply Voltage	Applied Between $V_{CC}$ and COM	13.5	15.0	16.5	V
$V_{BS}$	High-Side Bias Voltage	Applied Between $V_B$ and $V_S$	13.5	15.0	16.5	V
$V_{IN(ON)}$	Input ON Threshold Voltage	Applied Between IN and COM	3.0	-	$V_{CC}$	V
$V_{IN(OFF)}$	Input OFF Threshold Voltage		0	-	0.6	V
$t_{dead}$	Blanking Time for Preventing Arm-Short	$V_{CC} = V_{BS} = 13.5 \sim 16.5 \text{ V}, T_J \leq 150^\circ\text{C}$	1.0	-	-	$\mu\text{s}$
$f_{PWM}$	PWM Switching Frequency	$T_J \leq 150^\circ\text{C}$	-	15	-	kHz



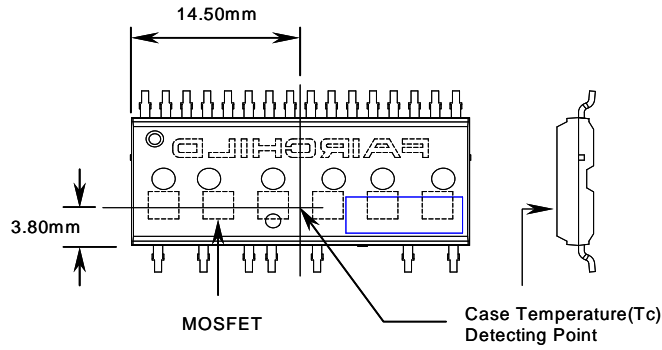
**Figure 2. Built-in Bootstrap Diode Characteristics (Typical)**



**Figure 3. Recommended MCU Interface and Bootstrap Circuit with Parameters**

**3rd Notes:**

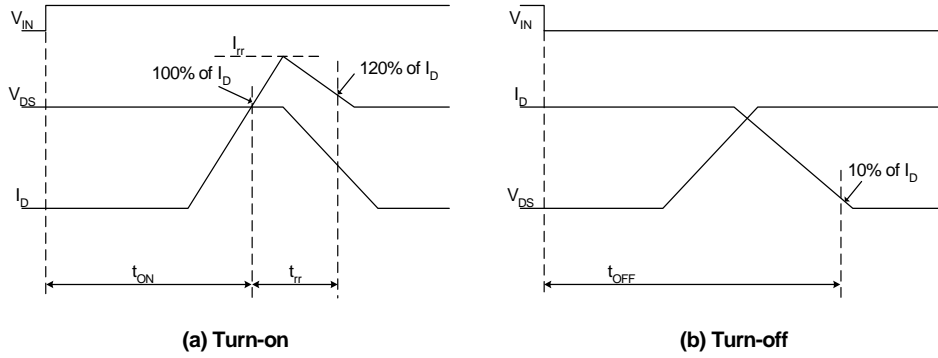
- Parameters for bootstrap circuit elements are dependent on PWM algorithm. For 15 kHz of switching frequency, typical example of parameters is shown above.
- RC-coupling (R<sub>5</sub> and C<sub>5</sub>) and C<sub>4</sub> at each input of Motion SPM 5 product and MCU (Indicated as Dotted Lines) may be used to prevent improper signal due to surge-noise.
- Bold lines should be short and thick in PCB pattern to have small stray inductance of circuit, which results in the reduction of surge-voltage. Bypass capacitors such as C<sub>1</sub>, C<sub>2</sub> and C<sub>3</sub> should have good high-frequency characteristics to absorb high-frequency ripple-current.



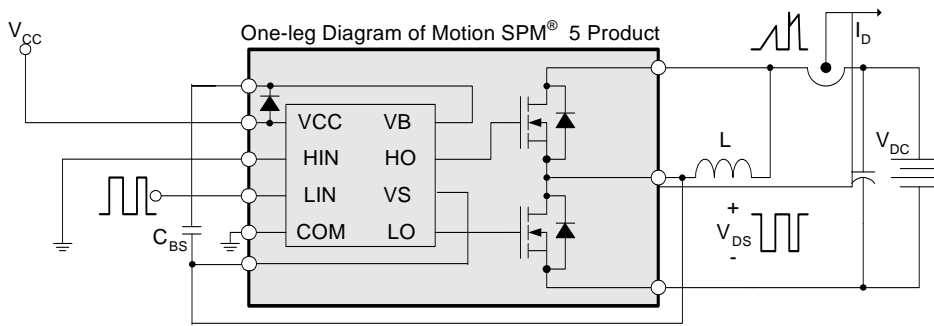
**Figure 4. Case Temperature Measurement**

**3rd Notes:**

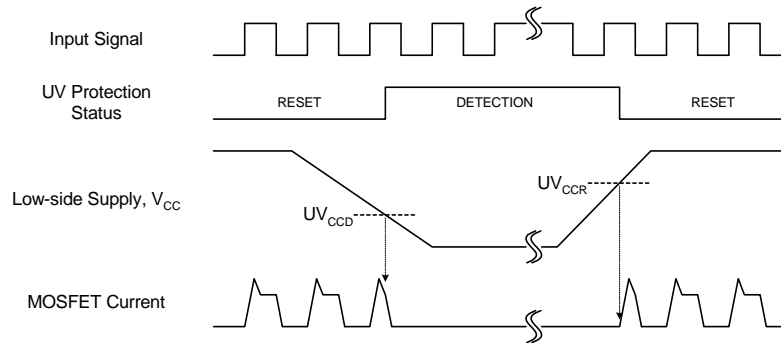
- Attach the thermocouple on top of the heat-sink of SPM 5 package (between SPM 5 package and heatsink if applied) to get the correct temperature measurement.



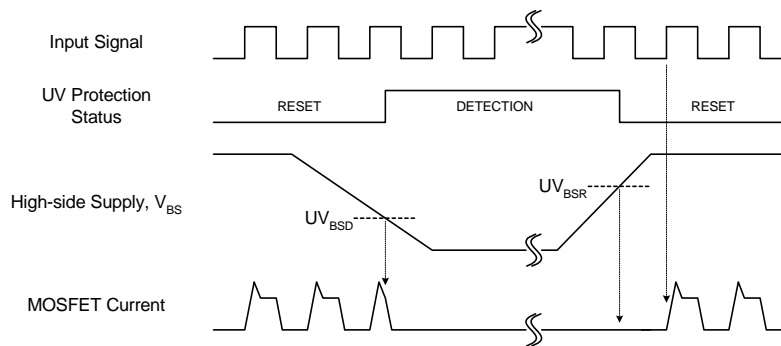
**Figure 5. Switching Time Definitions**



**Figure 6. Switching and RBSOA (Single-pulse) Test Circuit (Low-side)**

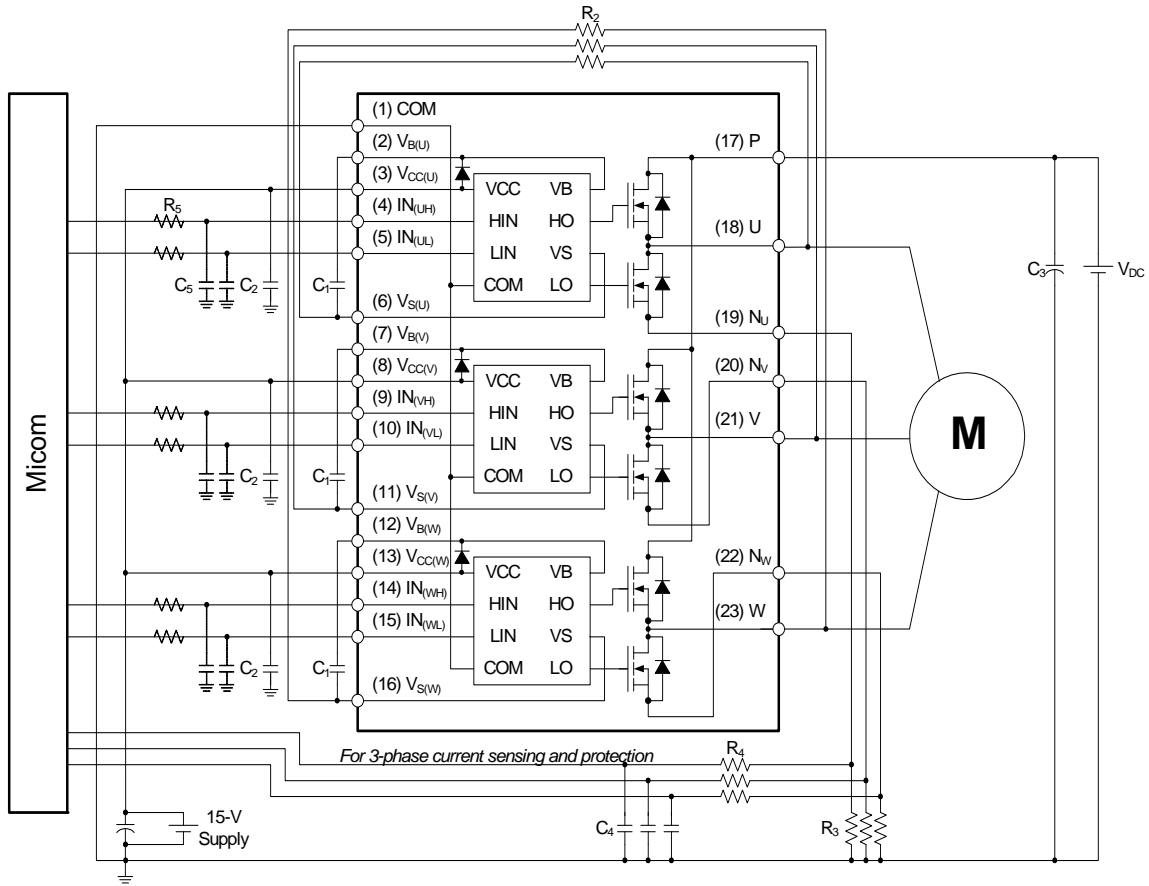


**Figure 7. Under-Voltage Protection (Low-Side)**



**Figure 8. Under-Voltage Protection (High-Side)**



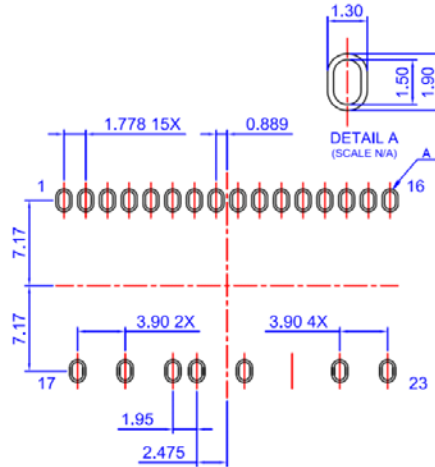
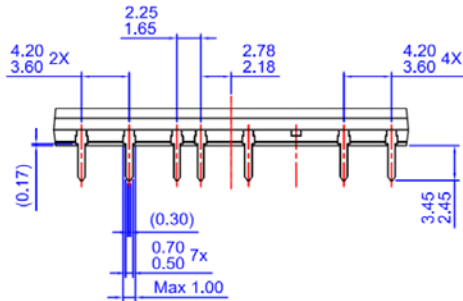
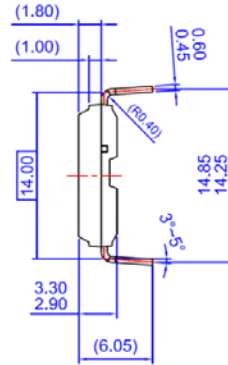
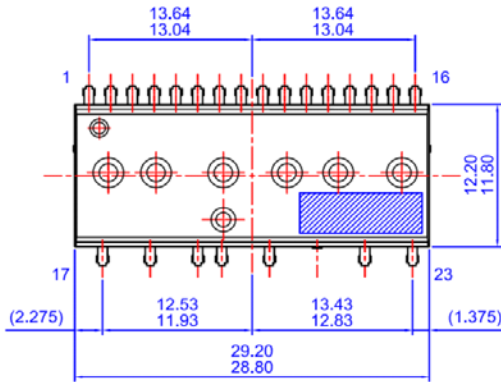
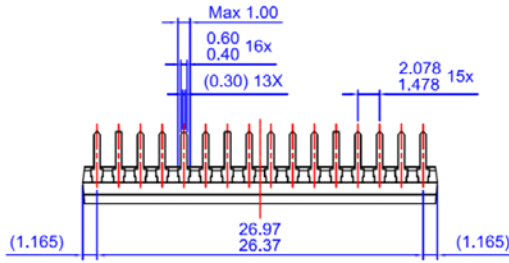


**Figure 9. Example of Application Circuit**

**4th Notes:**

1. About pin position, refer to Figure 1.
2. RC-coupling ( $R_5$  and  $C_5$ ,  $R_4$  and  $C_6$ ) and  $C_4$  at each input of Motion SPM® 5 product and MCU are useful to prevent improper input signal caused by surge-noise.
3. The voltage-drop across  $R_3$  affects the low-side switching performance and the bootstrap characteristics since it is placed between COM and the source terminal of the low-side MOSFET. For this reason, the voltage-drop across  $R_3$  should be less than 1 V in the steady-state.
4. Ground-wires and output terminals, should be thick and short in order to avoid surge-voltage and malfunction of HVIC.
5. All the filter capacitors should be connected close to Motion SPM 5 product, and they should have good characteristics for rejecting high-frequency ripple current.

## Detailed Package Outline Drawings



- NOTES: UNLESS OTHERWISE SPECIFIED  
 A) THIS PACKAGE DOES NOT COMPLY TO ANY CURRENT PACKAGING STANDARD  
 B) ALL DIMENSIONS ARE IN MILLIMETERS  
 C) DIMENSIONS ARE EXCLUSIVE OF BURRS, MOLD FLASH, AND TIE BAR EXTRUSIONS  
 D) ( ) IS REFERENCE  
 E) [ ] IS ASSY QUALITY  
 F) DRAWING FILENAME: MOD23DCREV2.0  
 G) FAIRCHILD SEMICONDUCTOR

### LAND PATTERN RECOMMENDATIONS

Package drawings are provided as a service to customers considering Fairchild components. Drawings may change in any manner without notice. Please note the revision and/or data on the drawing and contact a FairchildSemiconductor representative to verify or obtain the most recent revision. Package specifications do not expand the terms of Fairchild's worldwide terms and conditions, specifically the the warranty therein, which covers Fairchild products.



Always visit Fairchild Semiconductor's online packaging area for the most recent package drawings:

<http://www.fairchildsemi.com/dwg/MO/MOD23DB.pdf>



**TRADEMARKS**

The following includes registered and unregistered trademarks and service marks, owned by Fairchild Semiconductor and/or its global subsidiaries, and is not intended to be an exhaustive list of all such trademarks.

- |                                                                                              |                                                |                                       |                                                                                             |
|----------------------------------------------------------------------------------------------|------------------------------------------------|---------------------------------------|---------------------------------------------------------------------------------------------|
| AccuPower™                                                                                   | F-PFS™                                         | PowerTrench®                          | Sync-Lock™                                                                                  |
| AX-CAP®*                                                                                     | FRFET®                                         | PowerXS™                              | SYSTEM GENERAL®                                                                             |
| BitSiC™                                                                                      | Global Power Resource™                         | Programmable Active Droop™            | TinyBoost®                                                                                  |
| Build it Now™                                                                                | GreenBridge™                                   | QFET®                                 | TinyBuck®                                                                                   |
| CorePLUS™                                                                                    | Green FPS™                                     | QS™                                   | TinyCalc™                                                                                   |
| CorePOWER™                                                                                   | Green FPS™ e-Series™                           | Quiet Series™                         | TinyLogic®                                                                                  |
| CROSSVOLT™                                                                                   | Gmax™                                          | RapidConfigure™                       | TINYOPTO™                                                                                   |
| CTL™                                                                                         | GTO™                                           | Saving our world, 1mW/W/kW at a time™ | TinyPower™                                                                                  |
| Current Transfer Logic™                                                                      | IntelliMAX™                                    | SignalWise™                           | TinyPWM™                                                                                    |
| DEUXPEED®                                                                                    | ISOPLANAR™                                     | SmartMax™                             | TinyWire™                                                                                   |
| Dual Cool™                                                                                   | Making Small Speakers Sound Louder and Better™ | SMART START™                          | TransiC™                                                                                    |
| EcoSPARK®                                                                                    | MegaBuck™                                      | Solutions for Your Success™           | TriFault Detect™                                                                            |
| EfficientMax™                                                                                | MICROCOUPLER™                                  | SPM®                                  | TRUECURRENT®*                                                                               |
| ESBC™                                                                                        | MicroFET™                                      | STEALTH™                              | µSerDes™                                                                                    |
|  Fairchild® | MicroPak™                                      | SuperFET®                             |  SerDes® |
| Fairchild Semiconductor®                                                                     | MicroPak2™                                     | SuperSOT™-3                           | UHC®                                                                                        |
| FACT Quiet Series™                                                                           | MillerDrive™                                   | SuperSOT™-6                           | Ultra FRFET™                                                                                |
| FACT®                                                                                        | MotionMax™                                     | SuperSOT™-8                           | UniFET™                                                                                     |
| FAST®                                                                                        | mWSaver®                                       | SupreMOS®                             | VCX™                                                                                        |
| FastVCore™                                                                                   | OptoHiT™                                       | SyncFET™                              | VisualMax™                                                                                  |
| FETBench™                                                                                    | OPTOLOGIC®                                     |                                       | VoltagePlus™                                                                                |
| FPS™                                                                                         | OPTOPLANAR®                                    |                                       | XS™                                                                                         |

\* Trademarks of System General Corporation, used under license by Fairchild Semiconductor.

**DISCLAIMER**

FAIRCHILD SEMICONDUCTOR RESERVES THE RIGHT TO MAKE CHANGES WITHOUT FURTHER NOTICE TO ANY PRODUCTS HEREIN TO IMPROVE RELIABILITY, FUNCTION, OR DESIGN. FAIRCHILD DOES NOT ASSUME ANY LIABILITY ARISING OUT OF THE APPLICATION OR USE OF ANY PRODUCT OR CIRCUIT DESCRIBED HEREIN; NEITHER DOES IT CONVEY ANY LICENSE UNDER ITS PATENT RIGHTS, NOR THE RIGHTS OF OTHERS. THESE SPECIFICATIONS DO NOT EXPAND THE TERMS OF FAIRCHILD'S WORLDWIDE TERMS AND CONDITIONS, SPECIFICALLY THE WARRANTY THEREIN, WHICH COVERS THESE PRODUCTS.

**LIFE SUPPORT POLICY**

FAIRCHILD'S PRODUCTS ARE NOT AUTHORIZED FOR USE AS CRITICAL COMPONENTS IN LIFE SUPPORT DEVICES OR SYSTEMS WITHOUT THE EXPRESS WRITTEN APPROVAL OF FAIRCHILD SEMICONDUCTOR CORPORATION.

As used herein:

- Life support devices or systems are devices or systems which, (a) are intended for surgical implant into the body or (b) support or sustain life, and (c) whose failure to perform when properly used in accordance with instructions for use provided in the labeling, can be reasonably expected to result in a significant injury of the user.
- A critical component in any component of a life support, device, or system whose failure to perform can be reasonably expected to cause the failure of the life support device or system, or to affect its safety or effectiveness.

**ANTI-COUNTERFEITING POLICY**

Fairchild Semiconductor Corporation's Anti-Counterfeiting Policy. Fairchild's Anti-Counterfeiting Policy is also stated on our external website, [www.fairchildsemi.com](http://www.fairchildsemi.com), under Sales Support.

Counterfeiting of semiconductor parts is a growing problem in the industry. All manufacturers of semiconductor products are experiencing counterfeiting of their parts. Customers who inadvertently purchase counterfeit parts experience many problems such as loss of brand reputation, substandard performance, failed applications, and increased cost of production and manufacturing delays. Fairchild is taking strong measures to protect ourselves and our customers from the proliferation of counterfeit parts. Fairchild strongly encourages customers to purchase Fairchild parts either directly from Fairchild or from Authorized Fairchild Distributors who are listed by country on our web page cited above. Products customers buy either from Fairchild directly or from Authorized Fairchild Distributors are genuine parts, have full traceability, meet Fairchild's quality standards for handling and storage and provide access to Fairchild's full range of up-to-date technical and product information. Fairchild and our Authorized Distributors will stand behind all warranties and will appropriately address any warranty issues that may arise. Fairchild will not provide any warranty coverage or other assistance for parts bought from Unauthorized Sources. Fairchild is committed to combat this global problem and encourage our customers to do their part in stopping this practice by buying direct or from authorized distributors.

**PRODUCT STATUS DEFINITIONS**

**Definition of Terms**

Datasheet Identification	Product Status	Definition
Advance Information	Formative / In Design	Datasheet contains the design specifications for product development. Specifications may change in any manner without notice.
Preliminary	First Production	Datasheet contains preliminary data; supplementary data will be published at a later date. Fairchild Semiconductor reserves the right to make changes at any time without notice to improve design.
No Identification Needed	Full Production	Datasheet contains final specifications. Fairchild Semiconductor reserves the right to make changes at any time without notice to improve the design.
Obsolete	Not In Production	Datasheet contains specifications on a product that is discontinued by Fairchild Semiconductor. The datasheet is for reference information only.

Rev. 166

ON Semiconductor and  are trademarks of Semiconductor Components Industries, LLC dba ON Semiconductor or its subsidiaries in the United States and/or other countries. ON Semiconductor owns the rights to a number of patents, trademarks, copyrights, trade secrets, and other intellectual property. A listing of ON Semiconductor's product/patent coverage may be accessed at [www.onsemi.com/site/pdf/Patent-Marking.pdf](http://www.onsemi.com/site/pdf/Patent-Marking.pdf). ON Semiconductor reserves the right to make changes without further notice to any products herein. ON Semiconductor makes no warranty, representation or guarantee regarding the suitability of its products for any particular purpose, nor does ON Semiconductor assume any liability arising out of the application or use of any product or circuit, and specifically disclaims any and all liability, including without limitation special, consequential or incidental damages. Buyer is responsible for its products and applications using ON Semiconductor products, including compliance with all laws, regulations and safety requirements or standards, regardless of any support or applications information provided by ON Semiconductor. "Typical" parameters which may be provided in ON Semiconductor data sheets and/or specifications can and do vary in different applications and actual performance may vary over time. All operating parameters, including "Typicals" must be validated for each customer application by customer's technical experts. ON Semiconductor does not convey any license under its patent rights nor the rights of others. ON Semiconductor products are not designed, intended, or authorized for use as a critical component in life support systems or any FDA Class 3 medical devices or medical devices with a same or similar classification in a foreign jurisdiction or any devices intended for implantation in the human body. Should Buyer purchase or use ON Semiconductor products for any such unintended or unauthorized application, Buyer shall indemnify and hold ON Semiconductor and its officers, employees, subsidiaries, affiliates, and distributors harmless against all claims, costs, damages, and expenses, and reasonable attorney fees arising out of, directly or indirectly, any claim of personal injury or death associated with such unintended or unauthorized use, even if such claim alleges that ON Semiconductor was negligent regarding the design or manufacture of the part. ON Semiconductor is an Equal Opportunity/Affirmative Action Employer. This literature is subject to all applicable copyright laws and is not for resale in any manner.

## PUBLICATION ORDERING INFORMATION

### LITERATURE FULFILLMENT:

Literature Distribution Center for ON Semiconductor  
19521 E. 32nd Pkwy, Aurora, Colorado 80011 USA  
**Phone:** 303-675-2175 or 800-344-3860 Toll Free USA/Canada  
**Fax:** 303-675-2176 or 800-344-3867 Toll Free USA/Canada  
**Email:** [orderlit@onsemi.com](mailto:orderlit@onsemi.com)

**N. American Technical Support:** 800-282-9855 Toll Free  
USA/Canada  
**Europe, Middle East and Africa Technical Support:**  
Phone: 421 33 790 2910  
**Japan Customer Focus Center**  
Phone: 81-3-5817-1050

**ON Semiconductor Website:** [www.onsemi.com](http://www.onsemi.com)  
**Order Literature:** <http://www.onsemi.com/orderlit>  
For additional information, please contact your local  
Sales Representative

## X-ON Electronics

Largest Supplier of Electrical and Electronic Components

*Click to view similar products for [Motor/Motion/Ignition Controllers & Drivers](#) category:*

*Click to view products by [ON Semiconductor](#) manufacturer:*

Other Similar products are found below :

[FSB50550TB2](#) [FSBF15CH60BTH](#) [MSVCPM2-63-12](#) [MSVGW45-14-2](#) [MSVGW54-14-3](#) [MSVGW54-14-5](#) [NTE7043](#) [LA6565VR-TLM-E](#)  
[LB11650-E](#) [LB1837M-TLM-E](#) [LB1845DAZ-XE](#) [LC898300XA-MH](#) [SS30-TE-L-E](#) [26700](#) [LV8281VR-TLM-H](#) [BA5839FP-E2](#) [IRAM236-1067A](#) [LA6584JA-AH](#) [LB11847L-E](#) [NCV70501DW002R2G](#) [AH293-PL-B](#) [STK672-630CN-E](#) [TND315S-TL-2H](#) [FNA23060](#) [FSB50250AB](#)  
[FNA41060](#) [MSVB54](#) [MSVBTC50E](#) [MSVCPM3-54-12](#) [MSVCPM3-63-12](#) [MSVCPM4-63-12](#) [MSVTA120](#) [FSB50550AB](#)  
[NCV70501DW002G](#) [LC898301XA-MH](#) [LV8413GP-TE-L-E](#) [MSVGW45-14-3](#) [MSVGW45-14-4](#) [MSVGW45-14-5](#) [MSVGW54-14-4](#)  
[STK984-091A-E](#) [MP6519GQ-Z](#) [LB11651-E](#) [IRSM515-025DA4](#) [LV8127T-TLM-H](#) [MC33812EKR2](#) [NCP81382MNTXG](#) [TDA21801](#)  
[LB11851FA-BH](#) [NCV70627DQ001R2G](#)