

ON Semiconductor

Is Now

onsemi™

To learn more about onsemi™, please visit our website at
www.onsemi.com

onsemi and **onsemi** and other names, marks, and brands are registered and/or common law trademarks of Semiconductor Components Industries, LLC dba "**onsemi**" or its affiliates and/or subsidiaries in the United States and/or other countries. **onsemi** owns the rights to a number of patents, trademarks, copyrights, trade secrets, and other intellectual property. A listing of **onsemi** product/patent coverage may be accessed at www.onsemi.com/site/pdf/Patent-Marking.pdf. **onsemi** reserves the right to make changes at any time to any products or information herein, without notice. The information herein is provided "as-is" and **onsemi** makes no warranty, representation or guarantee regarding the accuracy of the information, product features, availability, functionality, or suitability of its products for any particular purpose, nor does **onsemi** assume any liability arising out of the application or use of any product or circuit, and specifically disclaims any and all liability, including without limitation special, consequential or incidental damages. Buyer is responsible for its products and applications using **onsemi** products, including compliance with all laws, regulations and safety requirements or standards, regardless of any support or applications information provided by **onsemi**. "Typical" parameters which may be provided in **onsemi** data sheets and/or specifications can and do vary in different applications and actual performance may vary over time. All operating parameters, including "Typicals" must be validated for each customer application by customer's technical experts. **onsemi** does not convey any license under any of its intellectual property rights nor the rights of others. **onsemi** products are not designed, intended, or authorized for use as a critical component in life support systems or any FDA Class 3 medical devices or medical devices with a same or similar classification in a foreign jurisdiction or any devices intended for implantation in the human body. Should Buyer purchase or use **onsemi** products for any such unintended or unauthorized application, Buyer shall indemnify and hold **onsemi** and its officers, employees, subsidiaries, affiliates, and distributors harmless against all claims, costs, damages, and expenses, and reasonable attorney fees arising out of, directly or indirectly, any claim of personal injury or death associated with such unintended or unauthorized use, even if such claim alleges that **onsemi** was negligent regarding the design or manufacture of the part. **onsemi** is an Equal Opportunity/Affirmative Action Employer. This literature is subject to all applicable copyright laws and is not for resale in any manner. Other names and brands may be claimed as the property of others.



Is Now Part of



ON Semiconductor®

To learn more about ON Semiconductor, please visit our website at
www.onsemi.com

Please note: As part of the Fairchild Semiconductor integration, some of the Fairchild orderable part numbers will need to change in order to meet ON Semiconductor's system requirements. Since the ON Semiconductor product management systems do not have the ability to manage part nomenclature that utilizes an underscore (_), the underscore (_) in the Fairchild part numbers will be changed to a dash (-). This document may contain device numbers with an underscore (_). Please check the ON Semiconductor website to verify the updated device numbers. The most current and up-to-date ordering information can be found at www.onsemi.com. Please email any questions regarding the system integration to Fairchild_questions@onsemi.com.

ON Semiconductor and the ON Semiconductor logo are trademarks of Semiconductor Components Industries, LLC dba ON Semiconductor or its subsidiaries in the United States and/or other countries. ON Semiconductor owns the rights to a number of patents, trademarks, copyrights, trade secrets, and other intellectual property. A listing of ON Semiconductor's product/patent coverage may be accessed at www.onsemi.com/site/pdf/Patent-Marking.pdf. ON Semiconductor reserves the right to make changes without further notice to any products herein. ON Semiconductor makes no warranty, representation or guarantee regarding the suitability of its products for any particular purpose, nor does ON Semiconductor assume any liability arising out of the application or use of any product or circuit, and specifically disclaims any and all liability, including without limitation special, consequential or incidental damages. Buyer is responsible for its products and applications using ON Semiconductor products, including compliance with all laws, regulations and safety requirements or standards, regardless of any support or applications information provided by ON Semiconductor. "Typical" parameters which may be provided in ON Semiconductor data sheets and/or specifications can and do vary in different applications and actual performance may vary over time. All operating parameters, including "Typicals" must be validated for each customer application by customer's technical experts. ON Semiconductor does not convey any license under its patent rights nor the rights of others. ON Semiconductor products are not designed, intended, or authorized for use as a critical component in life support systems or any FDA Class 3 medical devices or medical devices with a same or similar classification in a foreign jurisdiction or any devices intended for implantation in the human body. Should Buyer purchase or use ON Semiconductor products for any such unintended or unauthorized application, Buyer shall indemnify and hold ON Semiconductor and its officers, employees, subsidiaries, affiliates, and distributors harmless against all claims, costs, damages, and expenses, and reasonable attorney fees arising out of, directly or indirectly, any claim of personal injury or death associated with such unintended or unauthorized use, even if such claim alleges that ON Semiconductor was negligent regarding the design or manufacture of the part. ON Semiconductor is an Equal Opportunity/Affirmative Action Employer. This literature is subject to all applicable copyright laws and is not for resale in any manner.



GF001H

Green-Mode Fairchild Power Switch (FPS™)

Features

- Advanced Burst Mode Operation at No-Load Condition
- 700 V High-Voltage JFET Startup Circuit
- Internal Avalanche-Rugged 700 V SenseFET
- Built-in 5 ms Soft-Start
- Peak-Current-Mode Control
- Cycle-by-Cycle Current Limiting
- Leading-Edge Blanking (LEB)
- Synchronized Slope Compensation
- Frequency Modulation to Attenuating EMI
- Internal Overload / Open-Loop Protection (OLP)
- V_{DD} Under-Voltage Lockout (UVLO)
- V_{DD} Over-Voltage Protection (OVP)
- Internal Auto-Restart Circuit (OLP, V_{DD} OVP)
- Adjustable Peak Current Limit

Description

The GF001H is a next-generation, Green-Mode Fairchild Power Switch (FPS™). It integrates an advanced current-mode Pulse Width Modulator (PWM) and an avalanche-rugged 700 V SenseFET in a single package, allowing auxiliary power designs with higher standby energy efficiency, reduced size, improved reliability, and lower system cost than previous solutions.

A new frequency modulation reduces EMI emission and built-in synchronized slope compensation allows stable peak-current-mode control over a wide range of input voltage.

Requiring a minimum number of external components, the GF001H provides a solid platform for cost-effective flyback converter design with low standby power consumption.

Ordering Information

Part Number	SenseFET	Operating Temperature Range	Package	Packing Method
GF001HN	2 A 700 V	-40°C to +105°C	8-Pin, Dual Inline Package (DIP)	Tube

Application Diagram

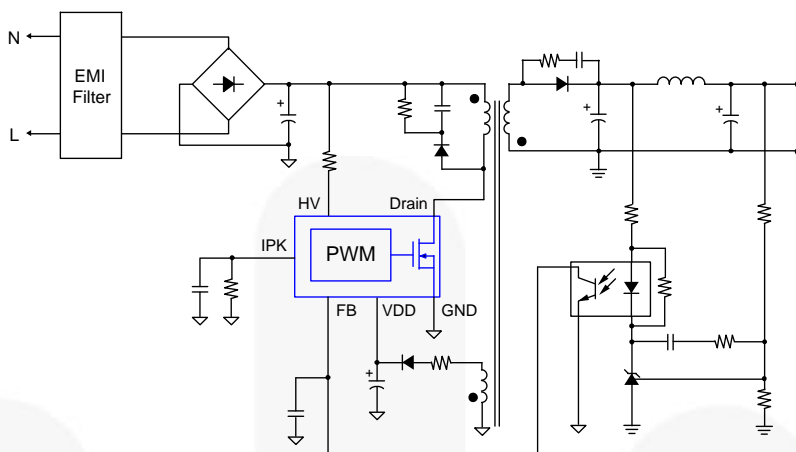

Figure 1. Typical Flyback Application

Output Power Table ⁽¹⁾

Product	230 V _{AC} ±15% ⁽²⁾		85-265 V _{AC}	
	Adapter ⁽³⁾	Open-Frame ⁽⁴⁾	Adapter ⁽³⁾	Open-Frame ⁽⁴⁾
GF001HN	14 W	20 W	11 W	16 W

Notes:

1. The maximum output power can be limited by junction temperature.
2. 230 V_{AC} or 100/115 V_{AC} with voltage doublers.
3. Typical continuous power in a non-ventilated enclosed adapter, with sufficient drain pattern of printed circuit board (PCB) as a heat sink, at 50°C ambient.
4. Maximum practical continuous power in an open-frame, design with sufficient drain pattern of printed circuit board (PCB) as a heat sink, at 50°C ambient.

Block Diagram

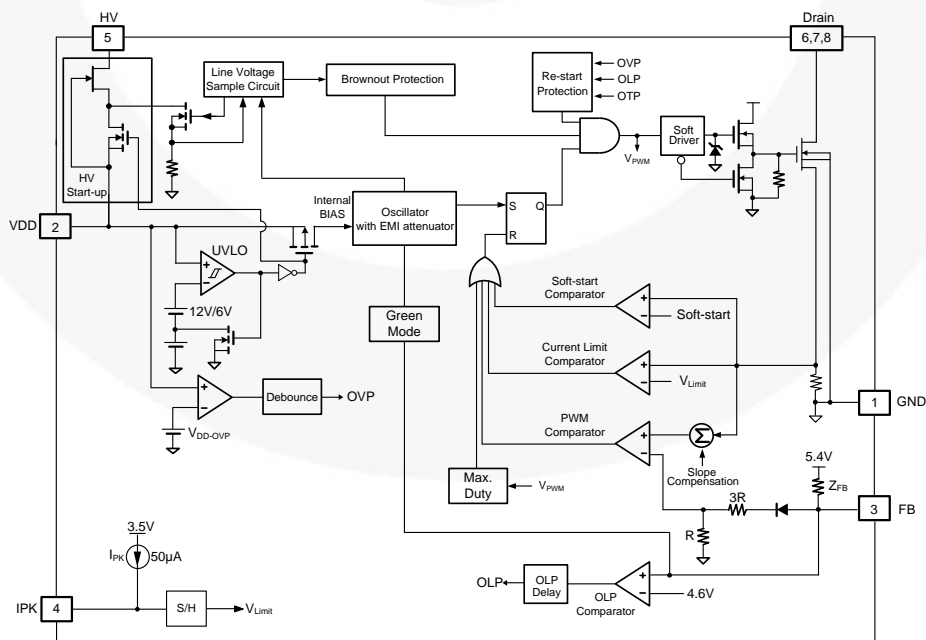
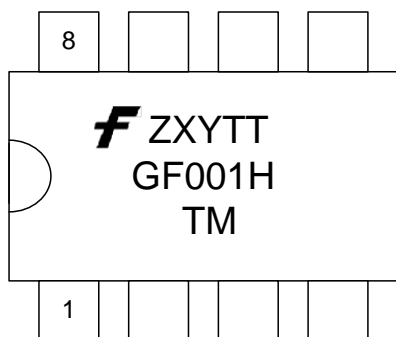

Figure 2. Internal Block Diagram

Marking Information



- F* – Fairchild Logo
- Z* – Plant Code
- X* – 1-Digit Year Code
- Y* – 1-Digit Week Code
- TT* – 2-Digit Die Run Code
- T* – Package Type (N: DIP)
- M* – Manufacture Flow Code

Figure 3. Top Mark

Pin Configuration

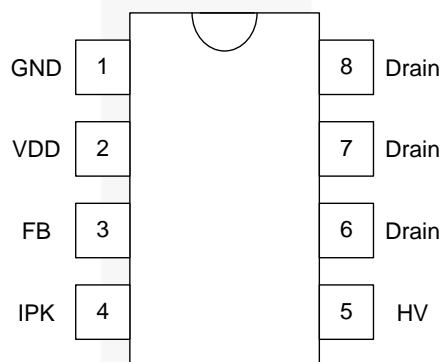

Figure 4. Pin Assignment

Pin Definitions

Pin #	Name	Description
1	GND	Ground. This pin internally connects to the SenseFET source and signal ground of the PWM controller.
2	VDD	Supply Voltage of the IC. Typically the hold-up capacitor connects from this pin to ground. A rectifier diode in series with the transformer auxiliary winding connects to this pin to supply bias during normal operation.
3	FB	Feedback. The signal from the external compensation circuit connects to this pin. The PWM duty cycle is determined by comparing the signal on this pin and the internal current-sense signal.
4	IPK	Adjust Peak Current. Typically a resistor connects from this pin to the GND pin to program the current-limit level. The internal current source (50 μ A) introduces voltage drop across the resistor, which determines the current-limit level of pulse-by-pulse current limit.
5	HV	Startup. Typically, resistors in series from DC line connect to this pin to supply internal bias and to charge the external capacitor connected between the VDD pin and the GND pin during startup. This pin is also used to sense the line voltage for brownout protection.
6	Drain	SenseFET Drain. This pin is designed to directly drive the transformer.
7		
8		

Absolute Maximum Ratings

Stresses exceeding the absolute maximum ratings may damage the device. The device may not function or be operable above the recommended operating conditions and stressing the parts to these levels is not recommended. In addition, extended exposure to stresses above the recommended operating conditions may affect device reliability. The absolute maximum ratings are stress ratings only.

Symbol	Parameter	Min.	Max.	Unit
V _{DRAIN}	Drain Pin Voltage ^(5,6)		700	V
I _{DM}	Drain Current Pulsed ⁽⁷⁾		8.0	A
E _{AS}	Single Pulsed Avalanche Energy ⁽⁸⁾		140	mJ
V _{DD}	DC Supply Voltage		25	V
V _{FB}	FB Pin Input Voltage	-0.3	6.0	V
V _{IPK}	IPK Pin Input Voltage	-0.3	6.0	V
V _{HV}	HV Pin Input Voltage		700	V
P _D	Power Dissipation (T _A < 50°C)		1.5	W
T _J	Operating Junction Temperature	-40	Internally Limited ⁽⁹⁾	°C
T _{STG}	Storage Temperature Range	-55	+150	°C
T _L	Lead Soldering Temperature (Wave Soldering or IR, 10 Seconds)		+260	°C

Notes:

- All voltage values, except differential voltages, are given with respect to the network ground terminal.
- Stresses beyond those listed under Absolute Maximum Ratings may cause permanent damage to the device.
- Non-repetitive rating: pulse width is limited by the maximum junction temperature.
- L = 51 mH, starting T_J = 25°C.
- Internally limited by Over-Temperature Protection(OTP). Refer to T_{OTP}.

Thermal Resistance Table

Symbol	Parameter	Value	Unit
θ _{JA}	Junction-to-Air Thermal Resistance	86	°C/W
ψ _{JT}	Junction-to-Package Thermal Resistance ⁽¹⁰⁾	20	°C/W

Note:

- Measured on the package top surface.

ESD Capability

Symbol	Parameter	Value	Unit
ESD	Human Body Model, JESD22-A114 ⁽¹¹⁾	All pins excluding HV pin	7
		All pins including HV pin	3
	Charged Device Model, JESD22-C101 ⁽¹¹⁾	All pins excluding HV pin	2
		All pins including HV pin	2

Note:

- Meets JEDEC standards JESD 22-A114 and JESD 22-C101.

Electrical Characteristics

$V_{DD}=15\text{ V}$, and $T_A=25^\circ\text{C}$ unless otherwise specified.

Symbol	Parameter	Condition	Min.	Typ.	Max.	Unit
SenseFET Section⁽¹²⁾						
BV_{DSS}	Drain-Source Breakdown Voltage	$V_{DS} = 700\text{ V}$, $V_{GS} = 0\text{ V}$	700			V
I_{DSS}	Zero-Gate-Voltage Drain Current	$V_{DS} = 700\text{ V}$, $V_{GS} = 0\text{ V}$			50	μA
		$V_{DS} = 560\text{ V}$, $V_{GS} = 0\text{ V}$, $T_C = 125^\circ\text{C}$			200	
$R_{DS(ON)}$	Drain-Source On-State Resistance ⁽¹²⁾	$V_{GS} = 10\text{ V}$, $I_D = 0.5\text{ A}$		6.0	7.2	Ω
C_{ISS}	Input Capacitance	$V_{GS} = 0\text{ V}$, $V_{DS} = 25\text{ V}$, $f = 1\text{ MHz}$		550	715	pF
C_{OSS}	Output Capacitance	$V_{GS} = 0\text{ V}$, $V_{DS} = 25\text{ V}$, $f = 1\text{ MHz}$		38	50	pF
C_{RSS}	Reverse Transfer Capacitance	$V_{GS} = 0\text{ V}$, $V_{DS} = 25\text{ V}$, $f = 1\text{ MHz}$		17	26	pF
$t_{d(on)}$	Turn-On Delay	$V_{DS} = 350\text{ V}$, $I_D = 1.0\text{ A}$		20	50	ns
t_r	Rise Time	$V_{DS} = 350\text{ V}$, $I_D = 1.0\text{ A}$		15	40	ns
$t_{d(off)}$	Turn-Off Delay	$V_{DS} = 350\text{ V}$, $I_D = 1.0\text{ A}$		55	120	ns
t_f	Fall Time	$V_{DS} = 350\text{ V}$, $I_D = 1.0\text{ A}$		25	60	ns
Control Section						
VDD Section						
V_{DD-ON}	UVLO Start Threshold Voltage		11	12	13	V
$V_{DD-OFF1}$	UVLO Stop Threshold Voltage		5	6	7	V
$V_{DD-OFF2}$	I_{DD-OLP} Enable Threshold Voltage		8	9	10	V
V_{DD-OLP}	V_{DD} Voltage Threshold for HV Startup Turn-On at Protection Mode		5	6	7	V
I_{DD-ST}	Startup Supply Current	$V_{DD-ON} - 0.16\text{ V}$			30	μA
I_{DD-OP1}	Operating Supply Current with Normal Switching Operation	$V_{DD}=15\text{ V}$, $V_{FB}=3\text{ V}$			3.8	mA
I_{DD-OP2}	Operating Supply Current without Switching Operation	$V_{DD}=15\text{ V}$, $V_{FB}=1\text{ V}$			1.8	mA
I_{DD-OLP}	Internal Sinking Current	$V_{DD-OLP} + 0.1\text{ V}$	30	60	90	μA
V_{DD-OVP}	V_{DD} Over-Voltage Protection		23	24	25	V
$t_{D-VDDOVP}$	V_{DD} Over-Voltage Protection Debounce Time		40	105	170	μs
HV Section						
I_{HV}	Supply Current Drawn from HV Pin	$HV=120\text{ V}_{DC}$, $V_{DD}=0\text{ V}$ with $10\text{ }\mu\text{F}$	1.5		5.0	mA
V_{HV}	Minimum HV Voltage for V_{DD} being charged to V_{DD-ON}	$R_{HV}=0\text{ }\Omega$, $T_A=-40^\circ\text{C}$ to 105°C	30			V
I_{HV-LC}	Leakage Current after Startup	$HV=700\text{ V}$, $V_{DD}=V_{DD-OFF1}+1\text{ V}$			10	μA
V_{DC-ON}	Brown-in Threshold Level (V_{DC})	DC Voltage Applied to HV Pin Through $200\text{ k}\Omega$ Resistor	104	114	124	V
V_{DC-OFF}	Brownout Threshold Level (V_{DC})		89	99	109	V
t_{UVP}	Brownout Protection Time		0.8	1.2	1.6	s

Continued on the following page...

Electrical Characteristics (Continued)V_{DD}=15 V, T_A=25°C unless otherwise specified.

Symbol	Parameter	Condition	Min.	Typ.	Max.	Unit
Oscillator Section						
f _{OSC}	Frequency in Nominal Mode	Center Frequency	94	100	106	kHz
f _M	Frequency Modulation			±6		kHz
f _{OSC-G}	Green-Mode Frequency		20	23	26	kHz
f _{DV}	Frequency Variation vs. V _{DD} Deviation	V _{DD} =11 V to 22 V			5	%
f _{DT}	Frequency Variation vs. Temperature Deviation ⁽¹²⁾	T _A =-40 °C to 105 °C			5	%
Feedback Input Section						
A _V	Internal Voltage Dividing Factor of FB Pin ⁽¹²⁾		1/4.5	1/4.0	1/3.5	V/V
Z _{FB}	Pull-Up Impedance of FB Pin		15	21	27	kΩ
V _{FB-OPEN}	FB Pin Pull-Up Voltage	FB Pin Open	5.2	5.4	5.6	V
V _{FB-OLP}	FB Voltage Threshold to Trigger Open-Loop Protection		4.3	4.6	4.9	V
t _{D-OLP}	Delay of FB Pin Open-Loop Protection		46	56	66	ms
V _{FB-N}	FB Voltage Threshold to Exit Green Mode	V _{FB} is Rising	2.4	2.6	2.8	V
V _{FB-G}	FB Voltage Threshold to Enter Green Mode	V _{FB} is Falling		V _{FB-N} -0.2		V
V _{FB-ZDC}	FB Voltage Threshold to Enter Zero-Duty State	V _{FB} is Falling	1.1	1.2	1.3	V
V _{FB-ZDCR}	FB Voltage Threshold to Exit Zero-Duty State	V _{FB} is Rising		V _{FB-ZDC} +0.1		V
IPK Pin Section						
V _{IPK-OPEN}	IPK Pin Open Voltage		3.0	3.5	4.0	V
V _{IPK-H}	Internal Upper Clamping Voltage of IPK Pin ⁽¹²⁾				3	V
V _{IPK-L}	Internal Lower Clamping Voltage of IPK Pin ⁽¹²⁾		1.5			V
I _{PK}	Internal Current Source of IPK Pin	T _A =-40 °C to 105 °C, V _{IPK} =2.25 V	45	50	55	μA
I _{LMT-H}	Flat Threshold Level of Current Limit for the Highest IPK Level	V _{IPK} =3 V	0.90	1.00	1.10	A
I _{LMT-L}	Flat Threshold Level of Current Limit for the Lowest IPK Level	V _{IPK} =1.5 V	0.45	0.50	0.55	A
Current-Sense Section⁽¹³⁾						
t _{PD}	Current Limit Turn-Off Delay ⁽¹⁴⁾			100	200	ns
t _{LEB}	Leading-Edge Blanking Time ⁽¹⁴⁾		160	210	260	ns
t _{SS}	Soft-Start Time ⁽¹²⁾			5		ms
GATE Section⁽¹³⁾						
DCY _{MAX}	Maximum Duty Cycle		70			%
Over Temperature Protection Section (OTP)						
T _{OTP}	Junction Temperature to Trigger OTP ⁽¹²⁾		140			°C

Notes:

12. Guaranteed by design; not 100% tested in production.
13. Pulse test: pulse width ≤ 300 μs, duty ≤ 2%.
14. These parameters, although guaranteed, are tested in wafer-sort process.

Typical Characteristics

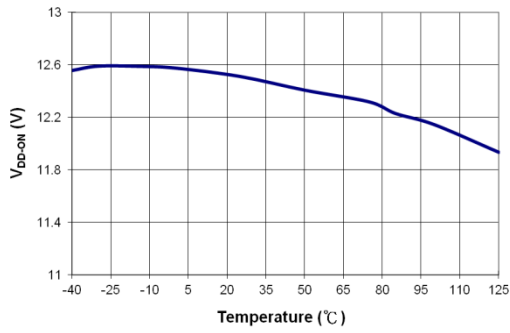

Figure 5. V_{DD-ON} vs. Temperature

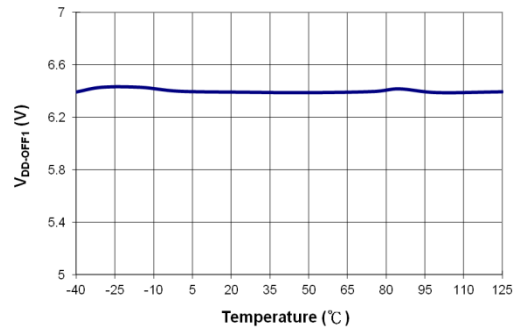

Figure 6. V_{DD-OFF1} vs. Temperature

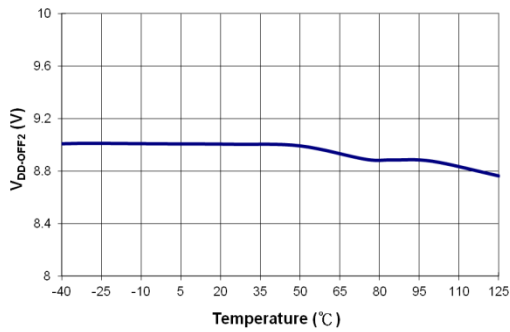

Figure 7. V_{DD-OFF2} vs. Temperature

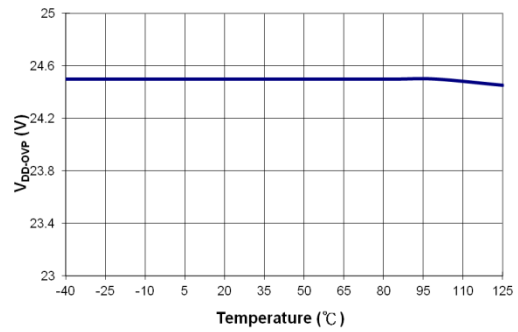

Figure 8. V_{DD-OVP} vs. Temperature

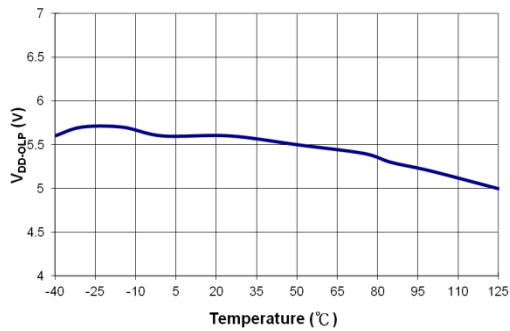

Figure 9. V_{DD-OLP} vs. Temperature

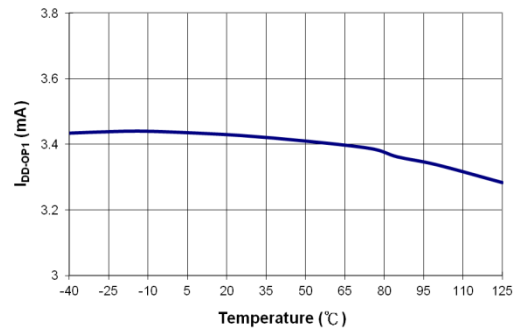

Figure 10. I_{DD-OP1} vs. Temperature

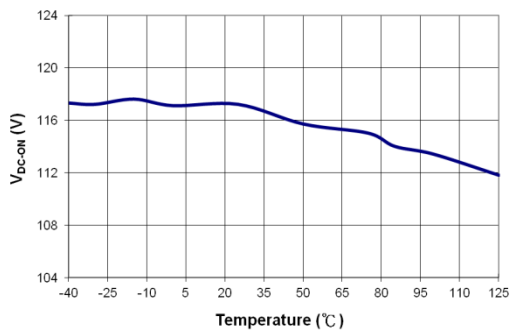

Figure 11. V_{DC-ON} vs. Temperature

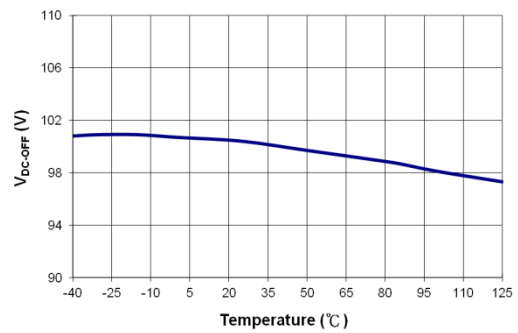

Figure 12. V_{DC-OFF} vs. Temperature

Typical Characteristics (Continued)

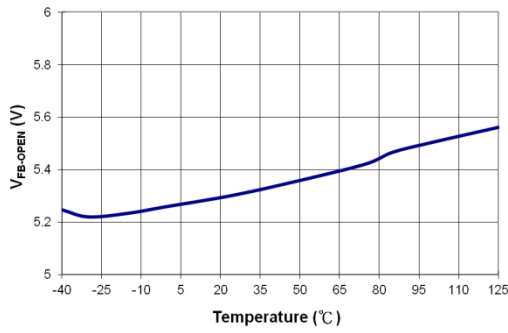

Figure 13. V_{FB-OPEN} vs. Temperature

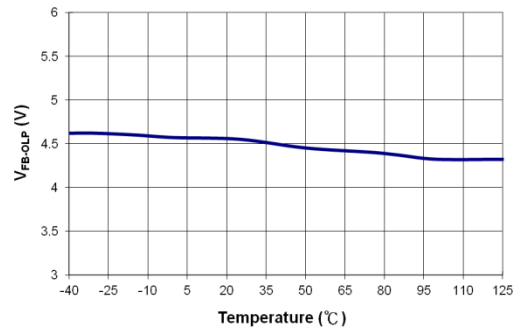

Figure 14. V_{FB-OLP} vs. Temperature

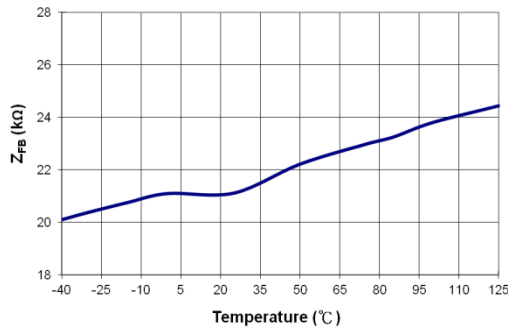

Figure 15. Z_{FB} vs. Temperature

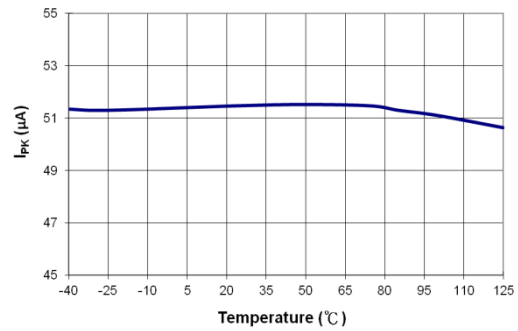

Figure 16. I_{PK} vs. Temperature

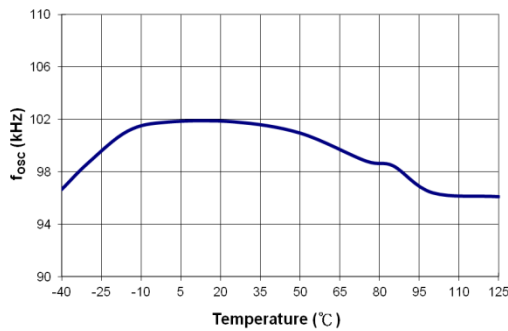

Figure 17. f_{OSC} vs. Temperature

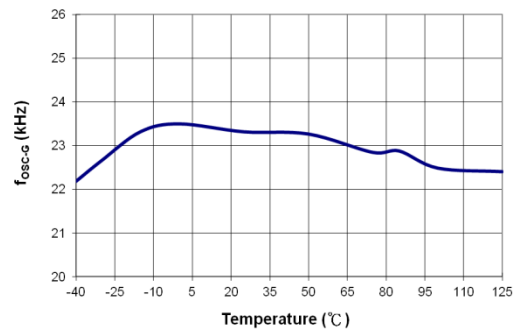

Figure 18. f_{OSC-G} vs. Temperature

Functional Description

Startup Operation

The HV pin is typically connected to the DC link input through one resistor (R_{HV}), as shown in Figure 19. When the DC input voltage is applied, the V_{DD} hold-up capacitor is charged by the line voltage through the resistor. After V_{DD} voltage reaches the turn-on threshold voltage (V_{DD-ON}), the startup circuit charging the V_{DD} capacitor is switched off and V_{DD} is supplied by the auxiliary winding of the transformer. Once the GF001H starts, it continues operation until V_{DD} drops below 6 V ($V_{DD-OFF1}$). The IC startup time with a given DC input voltage is:

$$t_{STARTUP} = R_{HV} \cdot C_{DD} \cdot \ln \frac{V_{DC}}{V_{DC} - V_{DD-ON}} \quad (1)$$

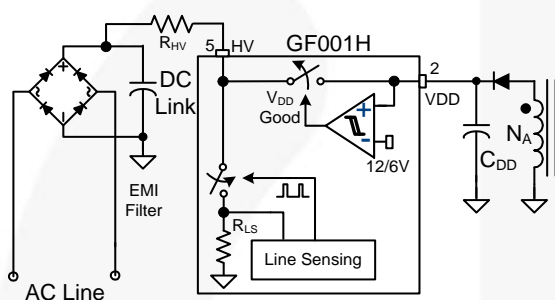

Figure 19. Startup Circuit

Brown-in/out Function

The HV pin can detect the DC link voltage using a switched voltage divider that consists of external resistor (R_{HV}) and internal resistor (R_{LS}), as shown in Figure 19. The internal DC input voltage sensing circuit detects the input voltage using a sampling circuit and peak-detection circuit. Since the voltage divider causes power consumption when it is switched on, the switching is driven by a signal with a very narrow pulse width to minimize power loss. The sampling frequency is adaptively changed according to the load condition to minimize power consumption in light-load condition.

Based on the detected DC input voltage, brown-in and brownout thresholds are determined. Since the internal resistor (R_{LS}) of the voltage divider is much smaller than R_{HV} , the thresholds are given:

$$\text{---} \quad (2)$$

$$\text{---} \quad (3)$$

PWM Control

The GF001H employs current-mode control, as shown in Figure 20. An opto-coupler (such as the H11A817A) and shunt regulator (such as the KA431) are typically used to implement the feedback network. Comparing the feedback voltage with the voltage across the R_{sense} resistor makes it possible to control the switching duty cycle. A synchronized positive slope is added to the SenseFET current information to guarantee stable current-mode control over a wide range of input voltage. The built-in slope compensation stabilizes the current loop and prevents sub-harmonic oscillation.

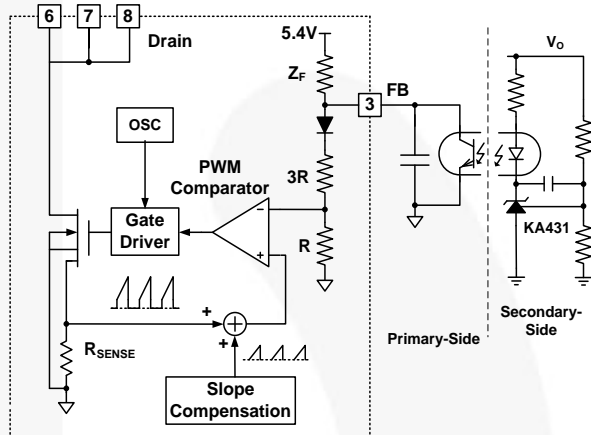

Figure 20. Current Mode Control

Soft-Start

The GF001H has an internal soft-start circuit that progressively increases the pulse-by-pulse current limit level of MOSFET during startup to establish the correct working conditions for transformers and capacitors, as shown in Figure 21. The current limit levels have nine steps, as shown in Figure 22. This prevents transformer saturation and reduces stress on the secondary diode during startup.

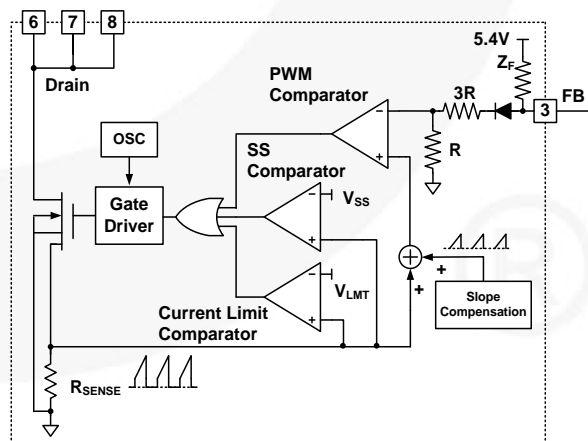

Figure 21. Soft-Start and Current-Limit Circuit

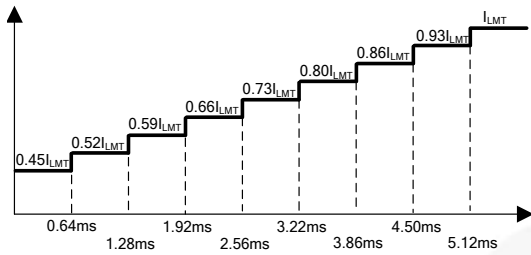

Figure 22. Current Limit Variation During Soft-Start

Adjustable Peak Current Limit

The peak current limit is programmable using a resistor on the IPK pin. The internal current 50 μ A source for the IPK pin generates voltage drop across the resistor. The voltage of the IPK pin determines the current-limit level. Since the upper and lower clamping voltage of the IPK pin are 3 V and 1.5 V, respectively; the suggested resistor value is from 30 k Ω to 60 k Ω .

Green Mode

As output load condition is reduced, the switching loss becomes the largest power loss factor. GF001H uses the FB pin voltage to monitor output load condition. As output load decreases, V_{FB} decreases and switching frequency declines, show in Figure 23. Once V_{FB} falls to 2.4 V, the switching frequency varies between 21.5 kHz and 24.5 kHz before Burst Mode operation. At Burst Mode operation, random frequency fluctuation still functions.

As V_{FB} falls below V_{FB-ZDC} , the GF001H enters Burst Mode, where PWM switching is disabled. The output voltage starts to drop, causing the feedback voltage to rise. Once V_{FB} rises above $V_{FB-ZDCR}$, switching resumes. Burst Mode alternately enables and disables switching, thereby reducing switching loss to reduce power consumption, shown in Figure 24.

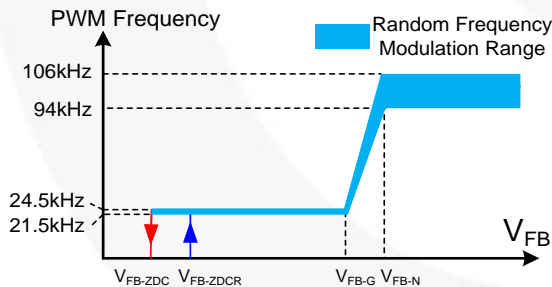

Figure 23. PWM Frequency

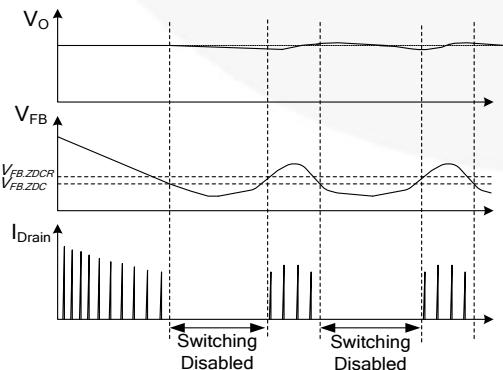

Figure 24. Burst-Mode Operation

Protections

The GF001H provides protection functions that include Overload / Open-Loop Protection (OLP) and Over-Voltage Protection (OVP). All the protections are implemented as Auto-Restart Mode. Once the fault condition is detected, switching is terminated and the SenseFET remains off, this causes V_{DD} to fall. When V_{DD} falls to 6 V, the protection is reset and HV startup circuit charges V_{DD} up to 12 V voltage, allowing restart.

Open-Loop / Overload Protection (OLP)

Because of the pulse-by-pulse current-limit capability, the maximum peak current through the SenseFET is limited and maximum input power is limited. If the output consumes more than the limited maximum power, the output voltage (V_O) drops below the set voltage. The current through the opto-coupler LED and the transistor become virtually zero and FB voltage is pulled HIGH, shown in Figure 25. If feedback voltage is above 4.6 V for longer than 56 ms, OLP is triggered. This protection is also triggered when the feedback loop is open due to a soldering defect.

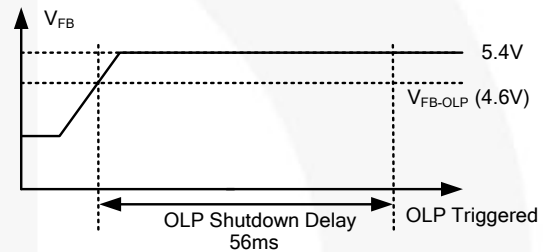

Figure 25. OLP Operation

V_{DD} Over-Voltage Protection (OVP)

If the secondary-side feedback circuit malfunctions or a solder defect causes an opening in the feedback path, the current through the opto-coupler transistor becomes virtually zero. Feedback voltage climbs in a similar manner to the overload situation, forcing the preset maximum current to be supplied to the SMPS until the overload protection triggers. Since more energy than required is provided to the output, the output voltage may exceed the rated voltage before the overload protection triggers, resulting in the breakdown of the devices in the secondary side. To prevent this situation, an OVP circuit is employed. Since V_{DD} voltage is proportional to the output voltage by the transformer coupling, the over-voltage of output is indirectly detected using V_{DD} voltage. The OVP is triggered when V_{DD} voltage reaches 24 V. Debounce time (typically 105 μ s) is applied to prevent false triggering by switching noise.

Two-Level UVLO

Since all the protections of the GF001H are auto-restart, the power supply repeats shutdown and restart until the fault condition is removed. GF001H has two-level UVLO, which is enabled when protection is triggered, to delay the re-startup by slowing down the discharge of V_{DD} . This effectively reduces the input power of the power supply during the fault condition, minimizing the voltage/current stress of the switching devices. Figure 26 shows the normal UVLO operation and two-step UVLO operation. When V_{DD} drops to 6 V without triggering the protection, PWM stops switching and V_{DD}

is charged up by the HV startup circuit. Meanwhile, when the protection is triggered, GF001H has a different V_{DD} discharge profile. Once the protection is triggered, the IC stops switching and V_{DD} drops. When V_{DD} drops to 9 V, the operating current becomes very small and V_{DD} is slowly discharged. When V_{DD} is naturally discharged down to 6 V, the protection is reset and V_{DD} is charged up by the HV startup circuit. Once V_{DD} reaches 12 V, the IC resumes switching operation.

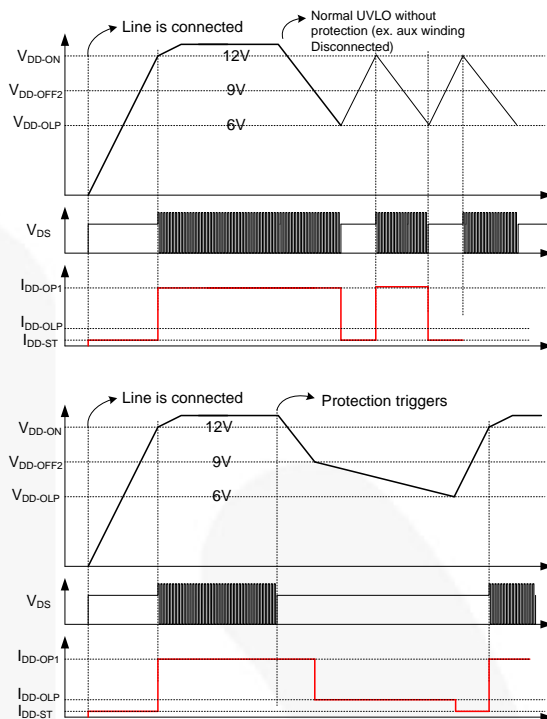
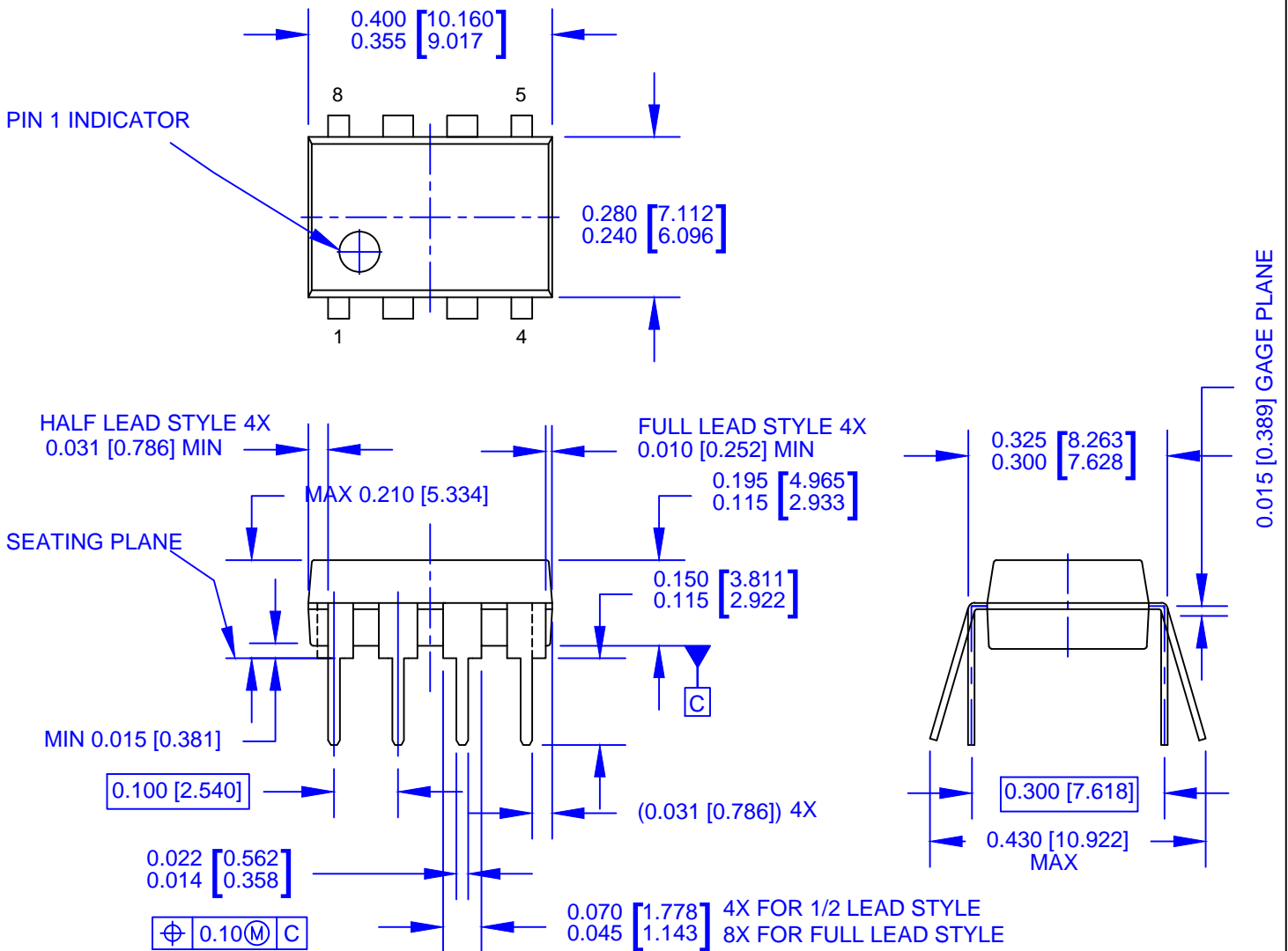

Figure 26. Two-Level UVLO



NOTES:

- A) THIS PACKAGE CONFORMS TO JEDEC MS-001 VARIATION BA WHICH DEFINES 2 VERSIONS OF THE PACKAGE TERMINAL STYLE WHICH ARE SHOWN HERE.
- B) CONTROLLING DIMS ARE IN INCHES
- C) DIMENSIONS ARE EXCLUSIVE OF BURRS, MOLD FLASH, AND TIE BAR EXTRUSIONS.
- D) DIMENSIONS AND TOLERANCES PER ASME Y14.5M-2009
- E) DRAWING FILENAME AND REVISION: MKT-N08MREV2.



ON Semiconductor and  are trademarks of Semiconductor Components Industries, LLC dba ON Semiconductor or its subsidiaries in the United States and/or other countries. ON Semiconductor owns the rights to a number of patents, trademarks, copyrights, trade secrets, and other intellectual property. A listing of ON Semiconductor's product/patent coverage may be accessed at www.onsemi.com/site/pdf/Patent-Marking.pdf. ON Semiconductor reserves the right to make changes without further notice to any products herein. ON Semiconductor makes no warranty, representation or guarantee regarding the suitability of its products for any particular purpose, nor does ON Semiconductor assume any liability arising out of the application or use of any product or circuit, and specifically disclaims any and all liability, including without limitation special, consequential or incidental damages. Buyer is responsible for its products and applications using ON Semiconductor products, including compliance with all laws, regulations and safety requirements or standards, regardless of any support or applications information provided by ON Semiconductor. "Typical" parameters which may be provided in ON Semiconductor data sheets and/or specifications can and do vary in different applications and actual performance may vary over time. All operating parameters, including "Typicals" must be validated for each customer application by customer's technical experts. ON Semiconductor does not convey any license under its patent rights nor the rights of others. ON Semiconductor products are not designed, intended, or authorized for use as a critical component in life support systems or any FDA Class 3 medical devices or medical devices with a same or similar classification in a foreign jurisdiction or any devices intended for implantation in the human body. Should Buyer purchase or use ON Semiconductor products for any such unintended or unauthorized application, Buyer shall indemnify and hold ON Semiconductor and its officers, employees, subsidiaries, affiliates, and distributors harmless against all claims, costs, damages, and expenses, and reasonable attorney fees arising out of, directly or indirectly, any claim of personal injury or death associated with such unintended or unauthorized use, even if such claim alleges that ON Semiconductor was negligent regarding the design or manufacture of the part. ON Semiconductor is an Equal Opportunity/Affirmative Action Employer. This literature is subject to all applicable copyright laws and is not for resale in any manner.

PUBLICATION ORDERING INFORMATION

LITERATURE FULFILLMENT:

Literature Distribution Center for ON Semiconductor
19521 E. 32nd Pkwy, Aurora, Colorado 80011 USA
Phone: 303-675-2175 or 800-344-3860 Toll Free USA/Canada
Fax: 303-675-2176 or 800-344-3867 Toll Free USA/Canada
Email: orderlit@onsemi.com

N. American Technical Support: 800-282-9855 Toll Free
USA/Canada
Europe, Middle East and Africa Technical Support:
Phone: 421 33 790 2910
Japan Customer Focus Center
Phone: 81-3-5817-1050

ON Semiconductor Website: www.onsemi.com
Order Literature: <http://www.onsemi.com/orderlit>
For additional information, please contact your local
Sales Representative

X-ON Electronics

Largest Supplier of Electrical and Electronic Components

Click to view similar products for [AC/DC Converters](#) category:

Click to view products by [ON Semiconductor](#) manufacturer:

Other Similar products are found below :

[BP5722A12](#) [ICE3AR0680VJZ](#) [ICE3AR2280CJZ](#) [ICE3BR0680JZ](#) [ICE3BR2280JZ](#) [SEA01](#) [FAN7621SSJX](#) [BP5011](#) [BP5055-12](#) [BP5718A12](#)
[ICE2QR4780Z](#) [NCP1124BP100G](#) [AP3983EP7-G1](#) [ICE2QR4765](#) [TEA19363T/1J](#) [AP3125CMKTR-G1](#) [ICE3AR10080CJZ](#) [SC1076P065G](#)
[47132](#) [47220](#) [47225](#) [APR3415BMTR-G1](#) [NCP1126BP100G](#) [HF500GP-40](#) [TNY179PN](#) [ICE3AR10080JZXKLA1](#) [BM2P0361-Z](#)
[BM2P249Q-Z](#) [BM521Q25F-GE2](#) [INN3164C-H107-TL](#) [HR1001CGS-P](#) [HR1001LGS-P](#) [BM2P131X-Z](#) [BM2P161X-Z](#) [BM2P181X-Z](#)
[BM2P201X-Z](#) [BM2P241X-Z](#) [LNK576DG-TL](#) [INN3278C-H215-TL](#) [INN3278C-H217-TL](#) [INN3678C-H605-TL](#) [INN3947CQ-TL](#)
[INN3073M-H606-TL](#) [INN4075C-H181-TL](#) [LNK3317D-TL](#) [INN4074C-H182-TL](#) [INN4075C-H182-TL](#) [LNK3316D-TL](#) [LNK3306D-TL](#)
[LNK3307D-TL](#)