

# MOSFET – Power, N-Channel, Ultrafet

150 V, 75 A, 16 mΩ

## HUF75852G3

### Features

- Ultra Low On-Resistance
  - ◆  $r_{DS(ON)} = 0.016 \Omega$ ,  $V_{GS} = 10 V$
- Simulation Models
  - ◆ Temperature Compensated PSPICE™ and SABER™ Electrical Models
  - ◆ Spice and SABER Thermal Impedance Models
  - ◆ [www.onsemi.com](http://www.onsemi.com)
- Peak Current vs Pulse Width Curve
- UIS Rating Curve
- This Device is Pb-Free, Halogen Free/BFR Free and is RoHS Compliant

### Packing

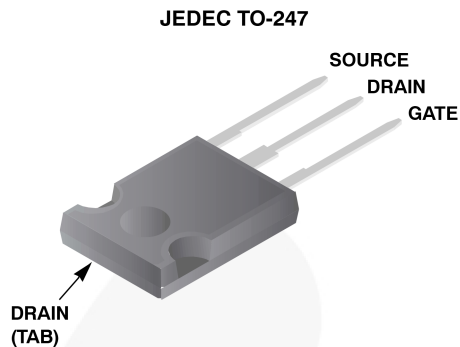
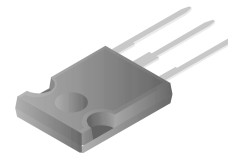
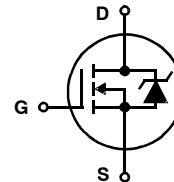

Figure 1.



ON Semiconductor®

[www.onsemi.com](http://www.onsemi.com)



TO-247-3LD  
CASE 340CK

### MARKING DIAGRAMS

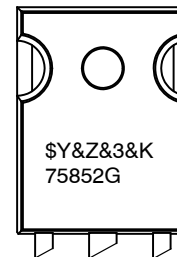

\$Y = ON Semiconductor Logo  
 &Z = Assembly Plant Code  
 &3 = Data Code (Year & Week)  
 &K = Lot  
 75852G = Specific Device Code

### ORDERING INFORMATION

Part Number	Package	Brand
HUF75852G3	TO-247-3LD	75852G

# HUF75852G3

## ABSOLUTE MAXIMUM RATINGS $T_C = 25^\circ\text{C}$ unless otherwise noted

Description	Symbol	Ratings	Units
Drain to Source Voltage (Note 1)	$V_{DSS}$	150	V
Drain to Gate Voltage ( $R_{GS} = 20\text{ k}\Omega$ ) (Note 1)	$V_{DGR}$	150	V
Gate to Source Voltage	$V_{GS}$	+20	V
Drain Current – Continuous ( $T_C = 25^\circ\text{C}$ , $V_{GS} = 10\text{ V}$ ) (Figure 2) – Continuous ( $T_C = 100^\circ\text{C}$ , $V_{GS} = 10\text{ V}$ ) (Figure 2) – Pulsed Drain Current	$I_D$ $I_D$ $I_{DM}$	75 75 Figure 4	A A
Pulsed Avalanche Rating	UIS	Figures 6, 14, 15	
Power Dissipation – Derate Above $25^\circ\text{C}$	$P_D$	500 3.33	W W/ $^\circ\text{C}$
Operating and Storage Temperature	$T_J$ , $T_{STG}$	-55 to 175	$^\circ\text{C}$
Maximum Temperature for Soldering – Leads at 0.063 in (1.6 mm) from Case for 10 s – Package Body for 10 s, See Techbrief TB334	$T_L$ $T_{pkg}$	300 260	$^\circ\text{C}$ $^\circ\text{C}$

Stresses exceeding those listed in the Maximum Ratings table may damage the device. If any of these limits are exceeded, device functionality should not be assumed, damage may occur and reliability may be affected.

1.  $T_J = 25^\circ\text{C}$  to  $150^\circ\text{C}$ .

# HUF75852G3

ELECTRICAL SPECIFICATIONS  $T_J = 25^\circ\text{C}$  unless otherwise noted

SYMBOL	PARAMETER	TEST CONDITIONS	MIN	TYP	MAX	UNITS
--------	-----------	-----------------	-----	-----	-----	-------

## OFF STATE SPECIFICATIONS

$BV_{DSS}$	Drain to Source Breakdown Voltage	$I_D = 250 \mu\text{A}$ , $V_{GS} = 0 \text{ V}$ (Figure 11)	150	-	-	V
$I_{DSS}$	Zero Gate Voltage Drain Current	$V_{DS} = 140 \text{ V}$ , $V_{GS} = 0 \text{ V}$	-	-	1	$\mu\text{A}$
		$V_{DS} = 135 \text{ V}$ , $V_{GS} = 0 \text{ V}$ , $T_C = 150^\circ\text{C}$	-	-	250	$\mu\text{A}$
$I_{GSS}$	Gate to Source Leakage Current	$V_{GS} = \pm 20 \text{ V}$	-	-	$\pm 100$	nA

## ON STATE SPECIFICATIONS

$V_{GS(TH)}$	Gate to Source Threshold Voltage	$V_{GS} = V_{DS}$ , $I_D = 250 \mu\text{A}$ (Figure 10)	2	-	4	V
$r_{DS(ON)}$	Drain to Source On Resistance	$I_D = 75 \text{ A}$ , $V_{GS} = 10 \text{ V}$ (Figure 9)	-	0.013	0.016	m $\Omega$

## THERMAL SPECIFICATIONS

$R_{\theta JC}$	Thermal Resistance Junction to Case	TO-247	-	-	0.30	$^\circ\text{C/W}$
$R_{\theta JA}$	Thermal Resistance Junction to Ambient		-	-	30	$^\circ\text{C/W}$

## SWITCHING SPECIFICATIONS ( $V_{GS} = 10 \text{ V}$ )

$t_{ON}$	Turn-On Time	$V_{DD} = 75 \text{ V}$ , $I_D \cong 75 \text{ A}$ , $V_{GS} = 10 \text{ V}$ , $R_{GS} = 2.0 \Omega$ (Figures 18, 19)	-	-	260	ns
$t_{d(ON)}$	Turn-On Delay Time		-	22	-	ns
$t_r$	Rise Time		-	151	-	ns
$t_{d(OFF)}$	Turn-Off Delay Time		-	82	-	ns
$t_f$	Fall Time		-	107	-	ns
$t_{OFF}$	Turn-Off Time		-	-	285	ns

## GATE CHARGE SPECIFICATIONS

$Q_{g(TOT)}$	Total Gate Charge	$V_{GS} = 0 \text{ V to } 20 \text{ V}$	$V_{DD} = 75 \text{ V}$ , $I_D = 75 \text{ A}$ , $I_{g(REF)} = 1.0 \text{ mA}$ (Figures 13, 16, 17)	-	400	480	nC
$Q_{g(10)}$	Gate Charge at 10 V	$V_{GS} = 0 \text{ V to } 10 \text{ V}$		-	215	260	nC
$Q_{g(TH)}$	Threshold Gate Charge	$V_{GS} = 0 \text{ V to } 2 \text{ V}$		-	15	17.5	nC
$Q_{gs}$	Gate to Source Gate Charge			-	25	-	nC
$Q_{gd}$	Gate to Drain "Miller" Charge			-	66	-	nC

## CAPACITANCE SPECIFICATIONS

$C_{ISS}$	Input Capacitance	$V_{DS} = 25 \text{ V}$ , $V_{GS} = 0 \text{ V}$ , $f = 1 \text{ MHz}$ (Figure 12)	-	7690	-	pF
$C_{OSS}$	Output Capacitance		-	1650	-	pF
$C_{RSS}$	Reverse Transfer Capacitance		-	535	-	pF

## SOURCE TO DRAIN DIODE SPECIFICATIONS

SYMBOL	PARAMETER	TEST CONDITIONS	MIN	TYP	MAX	UNITS
$V_{SD}$	Source to Drain Diode Voltage	$I_{SD} = 75 \text{ A}$	-	-	1.25	V
		$I_{SD} = 35 \text{ A}$	-	-	1.00	V
$t_{rr}$	Reverse Recovery Time	$I_{SD} = 75 \text{ A}$ , $dI_{SD}/dt = 100 \text{ A}/\mu\text{s}$	-	-	260	ns
$Q_{RR}$	Reverse Recovered Charge	$I_{SD} = 75 \text{ A}$ , $dI_{SD}/dt = 100 \text{ A}/\mu\text{s}$	-	-	183	nC

# HUF75852G3

## TYPICAL PERFORMANCE CURVES

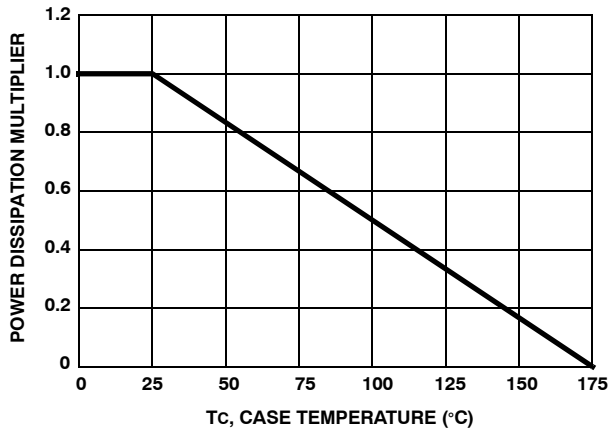

Figure 1. NORMALIZED POWER DISSIPATION vs CASE TEMPERATURE

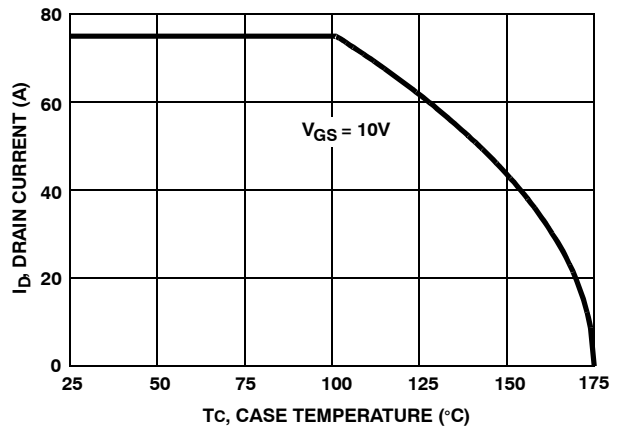

Figure 2. MAXIMUM CONTINUOUS DRAIN CURRENT vs CASE TEMPERATURE

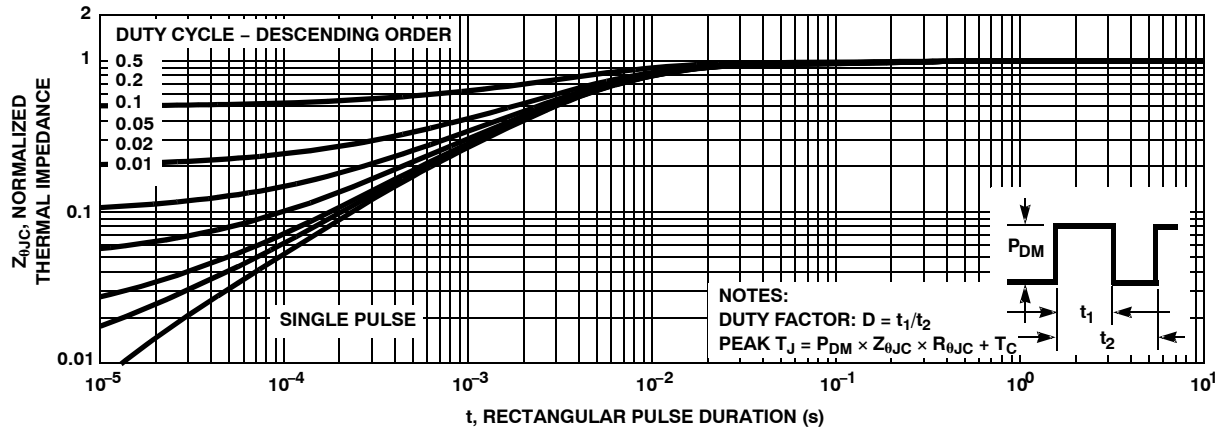

Figure 3. NORMALIZED MAXIMUM TRANSIENT THERMAL IMPEDANCE

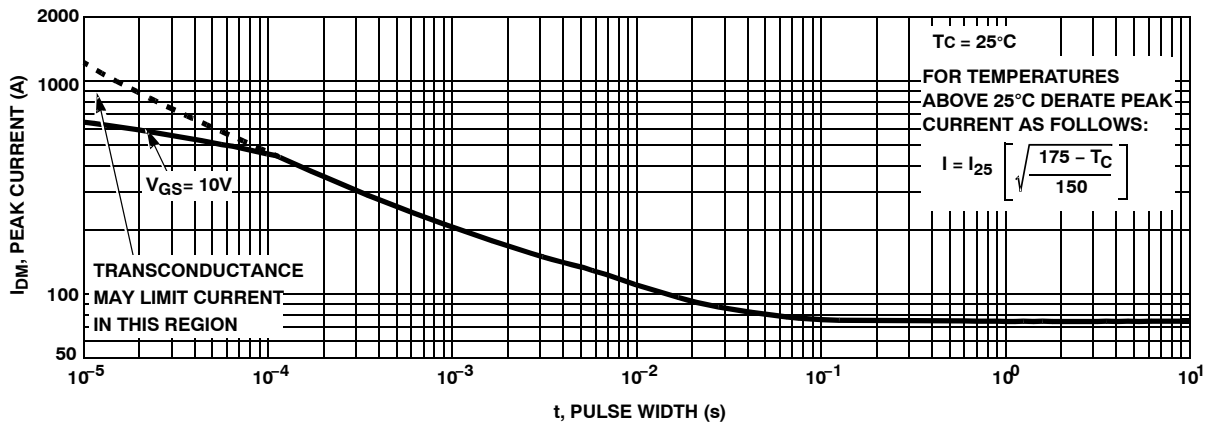

Figure 4. PEAK CURRENT CAPABILITY

TYPICAL PERFORMANCE CHARACTERISTICS (continued)

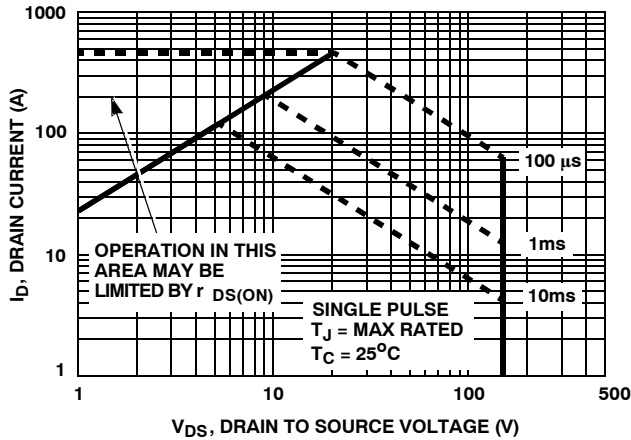
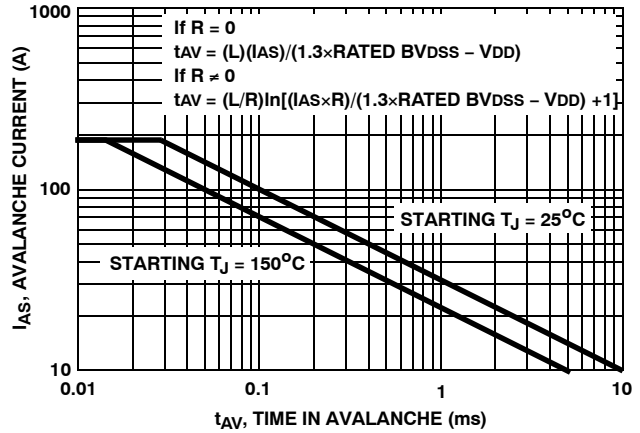

Figure 5. FORWARD BIAS SAFE OPERATING AREA



NOTE: Refer to Fairchild Application Notes AN9321 and AN9322.

Figure 6. UNCLAMPED INDUCTIVE SWITCHING CAPABILITY

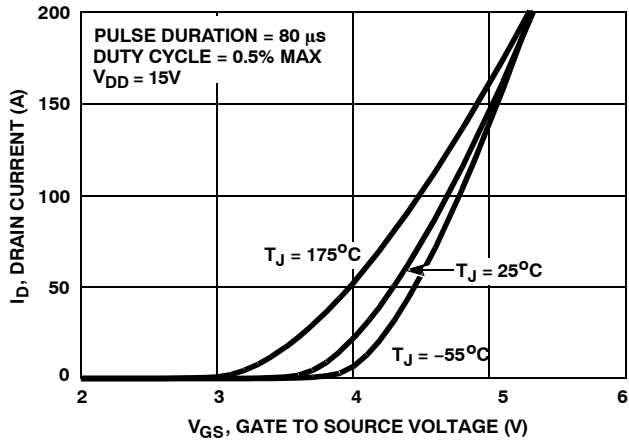

Figure 7. TRANSFER CHARACTERISTICS

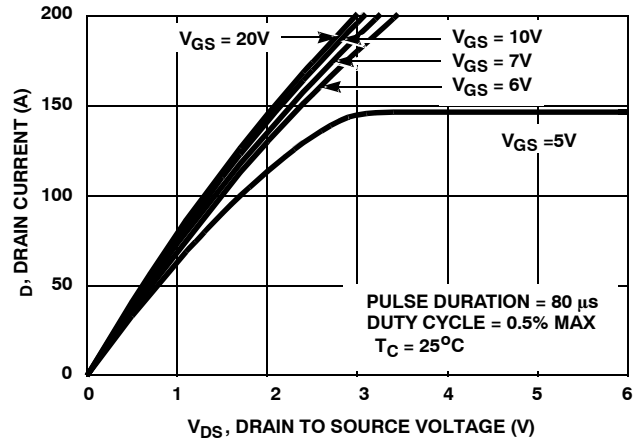

Figure 8. SATURATION CHARACTERISTICS

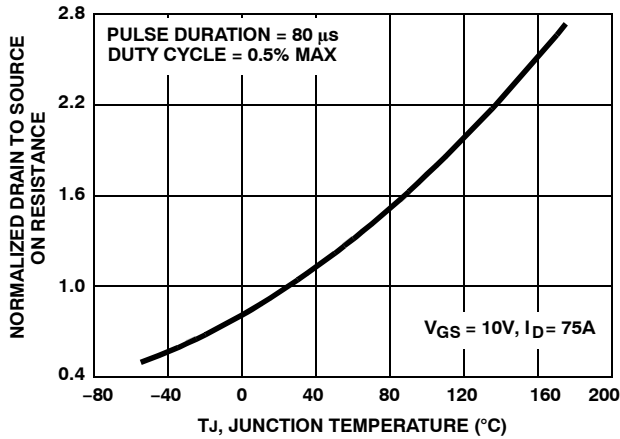

Figure 9. NORMALIZED DRAIN TO SOURCE ON RESISTANCE vs JUNCTION TEMPERATURE

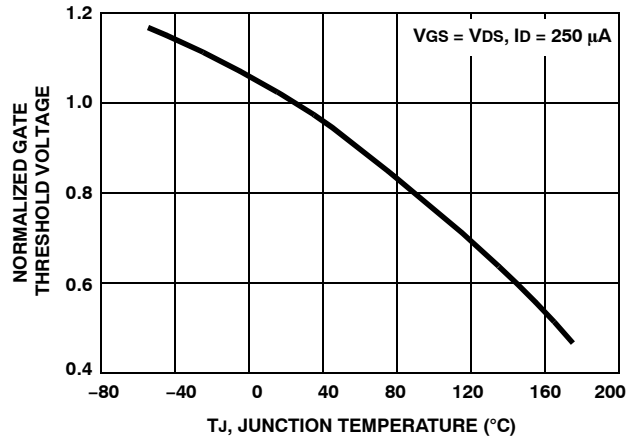

Figure 10. NORMALIZED GATE THRESHOLD VOLTAGE vs JUNCTION TEMPERATURE

TYPICAL PERFORMANCE CHARACTERISTICS (continued)

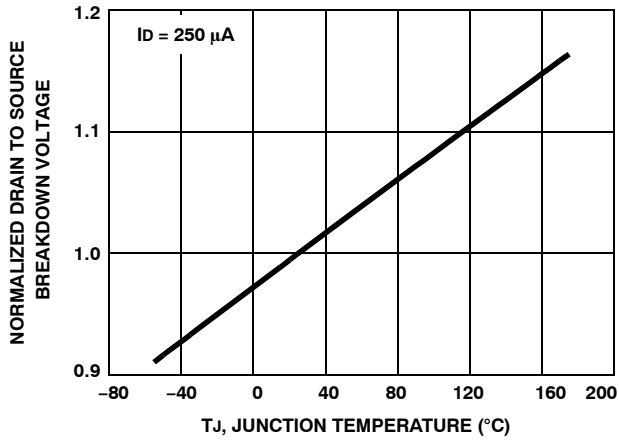

Figure 11. NORMALIZED DRAIN TO SOURCE BREAKDOWN VOLTAGE vs JUNCTION TEMPERATURE

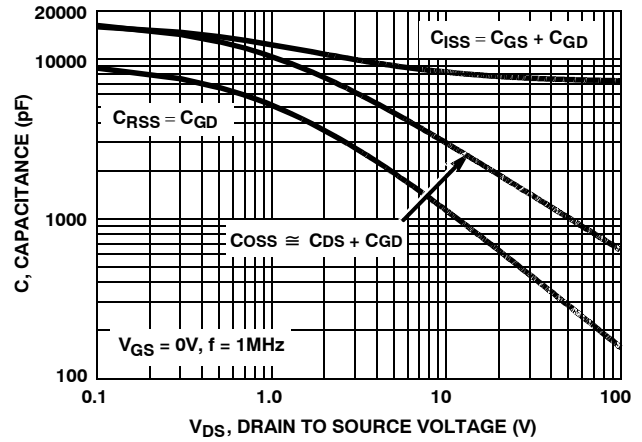
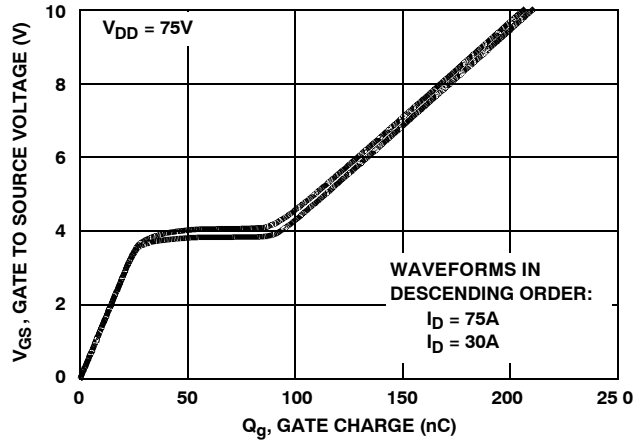

Figure 12. CAPACITANCE vs DRAIN TO SOURCE VOLTAGE



NOTE: Refer to Fairchild Application Notes AN7254 and AN7260.

Figure 13. GATE CHARGE WAVEFORMS FOR CONSTANT GATE CURRENT

TEST CIRCUITS AND WAVEFORMS

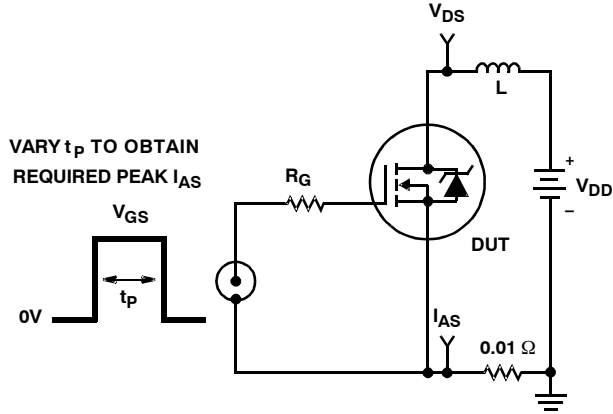

Figure 14. UNCLAMPED ENERGY TEST CIRCUIT

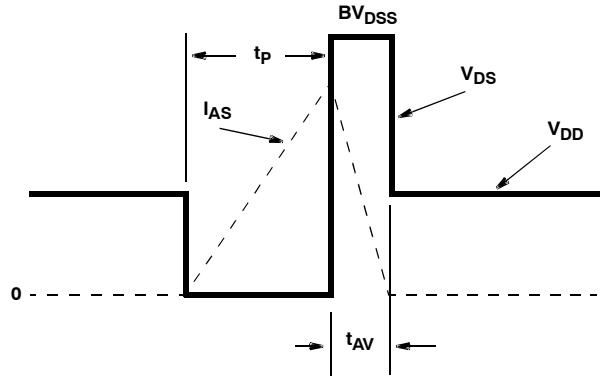

Figure 15. UNCLAMPED ENERGY WAVEFORMS

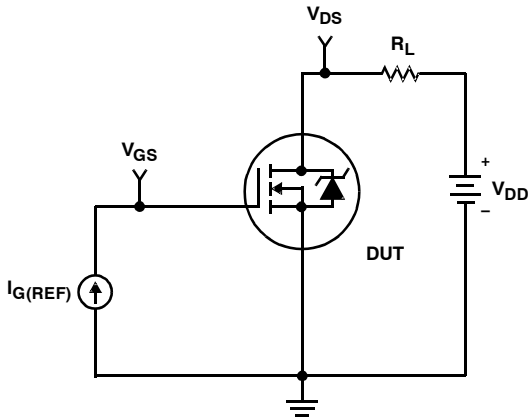

Figure 16. GATE CHARGE TEST CIRCUIT

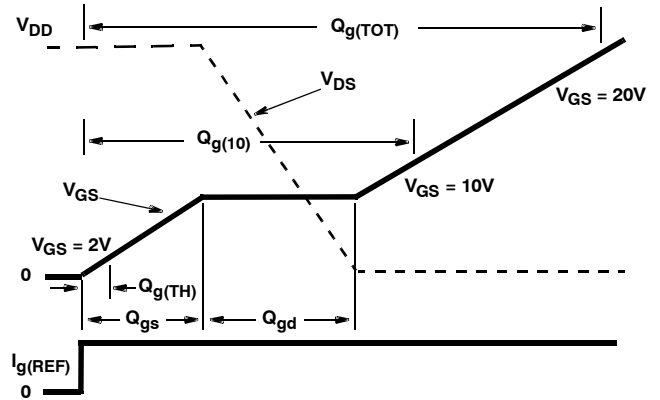

Figure 17. GATE CHARGE WAVEFORM

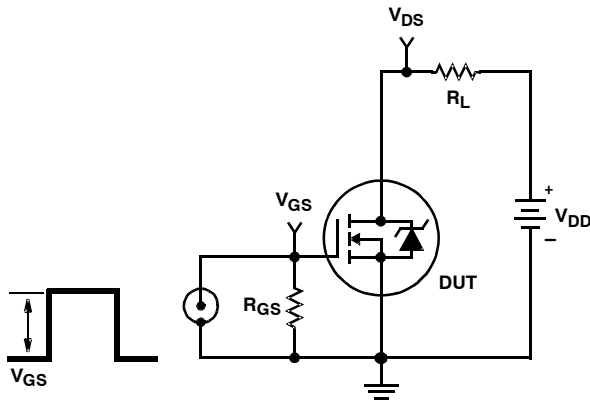

Figure 18. SWITCHING TIME TEST CIRCUIT

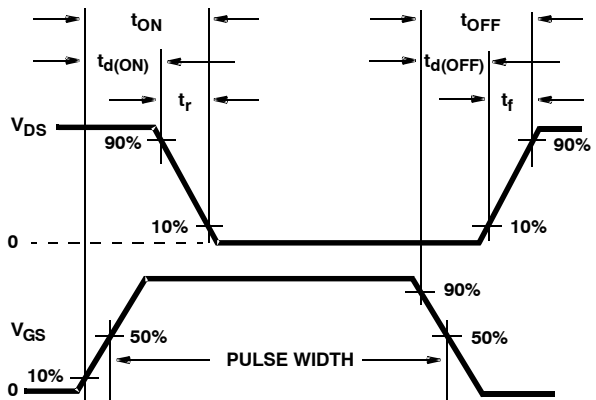

Figure 19. SWITCHING TIME WAVEFORM

# HUF75852G3

## PSPICE Electrical Model

.SUBCKT HUF75852 2 1 3 ; rev 26 Oct 1999

CA 12 8 12.0e-9  
 CB 15 14 12.0e-9  
 CIN 6 8 7.15e-9

DBODY 7 5 DBODYMOD  
 DBREAK 5 11 DBREAKMOD  
 DPLCAP 10 5 DPLCAPMOD

EBREAK 11 7 17 18 159.2  
 EDS 14 8 5 8 1  
 EGS 13 8 6 8 1  
 ESG 6 10 6 8 1  
 EVTHRES 6 21 19 8 1  
 EVTEMP 20 6 18 22 1

IT 8 17 1

LDRAIN 2 5 1.0e-9  
 LGATE 1 9 7.46e-9  
 LSOURCE 3 7 3.87e-9

MMED 16 6 8 8 MMEDMOD  
 MSTRO 16 6 8 8 MSTROMOD  
 MWEAK 16 21 8 8 MWEAKMOD

RBREAK 17 18 RBREAKMOD 1  
 RDRAIN 50 16 RDRAINMOD 9.50e-3  
 RGATE 9 20 0.80  
 RLDRAIN 2 5 10  
 RLGATE 1 9 74.6  
 RLSOURCE 3 7 38.7  
 RSLC1 5 51 RSLCMOD 1e-6  
 RSLC2 5 50 1e3  
 RSOURCE 8 7 RSOURCEMOD 2.37e-3  
 RVTHRES 22 8 RVTHRESMOD 1  
 RVTEMP 18 19 RVTEMPMOD 1

S1A 6 12 13 8 S1AMOD  
 S1B 13 12 13 8 S1BMOD  
 S2A 6 15 14 13 S2AMOD  
 S2B 13 15 14 13 S2BMOD

VBAT 22 19 DC 1

ESLC 51 50 VALUE={{(V(5,51) / ABS(V(5,51))) \* (PWR(V(5,51)) / (1e-6\*245), 2.5))}}

.MODEL DBODYMOD D (IS = 6.03e-12 RS = 2.17e-3 TRS1 = 1.97e-3 TRS2 = 1.03e-6 CJO = 7.91e-9 TT = 1.69e-7 M = 0.60)  
 .MODEL DBREAKMOD D (RS = 3.53e-1 TRS1 = 0 TRS2 = 0)  
 .MODEL DPLCAPMOD D (CJO = 9.52e-9 IS = 1e-3 0N = 1 M = 0.88)  
 .MODEL MMEDMOD NMOS (VTO = 3.05 KP = 8.50 IS = 1e-30 N = 10 TOX = 1 L = 1u W = 1u RG = 0.80)  
 .MODEL MSTROMOD NMOS (VTO = 3.53 KP = 215 IS = 1e-30 N = 10 TOX = 1 L = 1u W = 1u)  
 .MODEL MWEAKMOD NMOS (VTO = 2.63 KP = 0.075 IS = 1e-30 N = 10 TOX = 1 L = 1u W = 1u RG = 8.0)  
 .MODEL RBREAKMOD RES (TC1 = 1.12e-3 TC2 = -1.00e-7)  
 .MODEL RDRAINMOD RES (TC1 = 1.03e-2 TC2 = 3.04e-5)  
 .MODEL RSLCMOD RES (TC1 = 2.52e-3 TC2 = 0)  
 .MODEL RSOURCEMOD RES (TC1 = 1.01e-3 TC2 = 0)  
 .MODEL RVTHRESMOD RES (TC1 = -3.65e-3 TC2 = -1.55e-5)  
 .MODEL RVTEMPMOD RES (TC1 = -2.85e-3 TC2 = 0)

.MODEL S1AMOD VSWITCH (RON = 1e-5 ROFF = 0.1 VON = -3.5 VOFF = -3.0)  
 .MODEL S1BMOD VSWITCH (RON = 1e-5 ROFF = 0.1 VON = -3.0 VOFF = -3.5)  
 .MODEL S2AMOD VSWITCH (RON = 1e-5 ROFF = 0.1 VON = -2.5 VOFF = -0.5)  
 .MODEL S2BMOD VSWITCH (RON = 1e-5 ROFF = 0.1 VON = -0.5 VOFF = -2.5)

.ENDS

NOTE: For further discussion of the PSPICE model, consult **A New PSPICE Sub-Circuit for the Power MOSFET Featuring Global Temperature Options**; IEEE Power Electronics Specialist Conference Records, 1991, written by William J. Hepp and C. Frank W. Heatley.

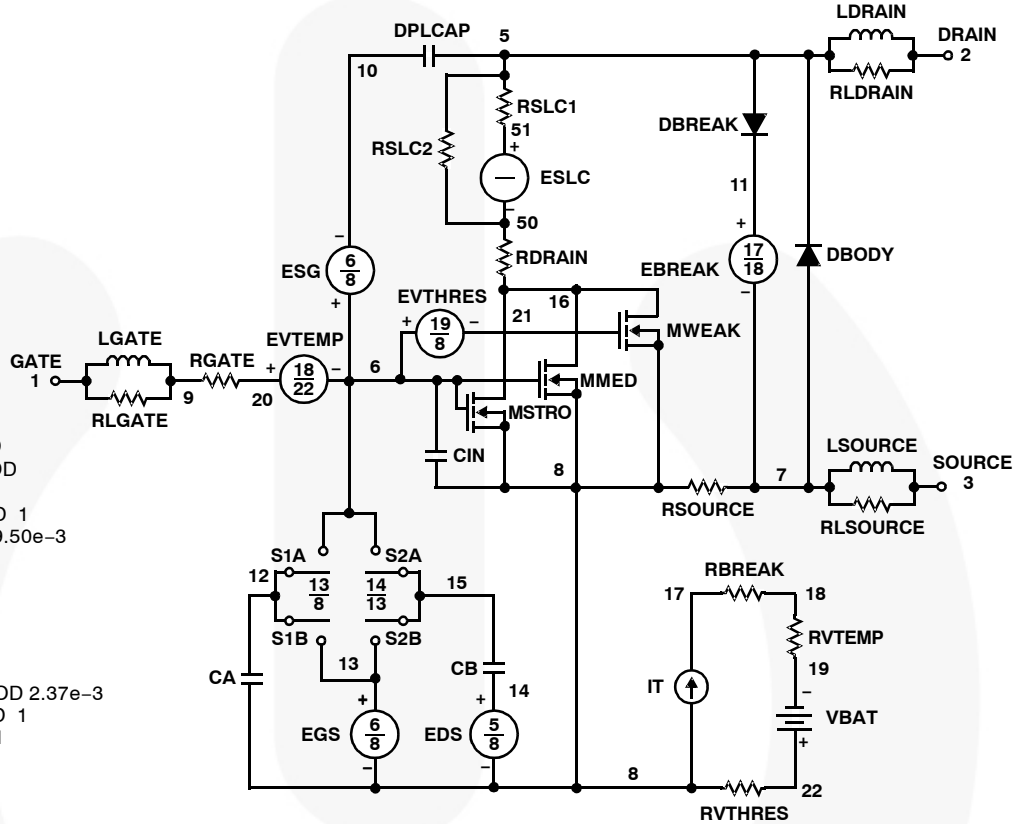



SABER Electrical Model

REV 26 Oct 1999

template huf75852 n2,n1,n3  
electrical n2,n1,n3

```
{
var i iscl
d..model dbodymod = (is = 6.03e-12, cjo = 7.91e-9, tt = 1.69e-7, m = 0.60)
d..model dbreakmod = ()
d..model dplcapmod = (cjo = 9.52e-9, is = 1e-30, n=1, m = 0.88 )
m..model mmedmod = (type=_n, vto = 3.05, kp = 8.50, is = 1e-30, tox = 1)
m..model mstrongmod = (type=_n, vto = 3.53, kp = 215, is = 1e-30, tox = 1)
m..model mweakmod = (type=_n, vto = 2.63, kp = 0.075, is = 1e-30, tox = 1)
sw_vcsp..model s1amod = (ron = 1e-5, roff = 0.1, von = -3.5, voff = -3)
sw_vcsp..model s1bmod = (ron = 1e-5, roff = 0.1, von = -3, voff = -3.5)
sw_vcsp..model s2amod = (ron = 1e-5, roff = 0.1, von = -2.5, voff = -0.5)
sw_vcsp..model s2bmod = (ron = 1e-5, roff = 0.1, von = -0.5, voff = -2.5)

```

```
c.ca n12 n8 = 12.0e-9
c.cb n15 n14 = 12.0e-9
c.cin n6 n8 = 7.15e-9

```

```
d.dbody n7 n71 = model=dbodymod
d.dbreak n72 n11 = model=dbreakmod
d.dplcap n10 n5 = model=dplcapmod

```

i.it n8 n17 = 1

```
l.l drain n2 n5 = 1.0e-9
l.l gate n1 n9 = 7.46e-9
l.l source n3 n7 = 3.87e-9

```

```
m.mmed n16 n6 n8 n8 = model=mmedmod, l=1u, w=1u
m.mstrong n16 n6 n8 n8 = model=mstrongmod, l=1u, w=1u
m.mweak n16 n21 n8 n8 = model=mweakmod, l=1u, w=1u

```

```
res.rbreak n17 n18 = 1, tc1 = 1.12e-3, tc2 = -1.00e-7
res.rbody n71 n5 = 2.17e-3, tc1 = 1.97e-3, tc2 = 1.03e-6
res.rdbreak n72 n5 = 3.53e-1, tc1 = 0, tc2 = 0
res.rdrain n50 n16 = 9.50e-3, tc1 = 1.03e-2, tc2 = 3.04e-5
res.rgate n9 n20 = 0.80
res.rldrain n2 n5 = 10
res.rlgate n1 n9 = 74.6
res.rlsource n3 n7 = 38.7
res.rslc1 n5 n51 = 1e-6, tc1 = 2.52e-4, tc2 = 0
res.rslc2 n5 n50 = 1e3
res.rsource n8 n7 = 2.37e-3, tc1 = 1.01e-3, tc2 = 0
res.rvtemp n18 n19 = 1, tc1 = -2.85e-3, tc2 = 0
res.rvthres n22 n8 = 1, tc1 = -3.65e-3, tc2 = -1.55e-5

```

```
spe.ebreak n11 n7 n17 n18 = 159.2
spe.eds n14 n8 n5 n8 = 1
spe.egs n13 n8 n6 n8 = 1
spe.esg n6 n10 n6 n8 = 1
spe.evtemp n20 n6 n18 n22 = 1
spe.evthres n6 n21 n19 n8 = 1

```

```
sw_vcsp.s1a n6 n12 n13 n8 = model=s1amod
sw_vcsp.s1b n13 n12 n13 n8 = model=s1bmod
sw_vcsp.s2a n6 n15 n14 n13 = model=s2amod
sw_vcsp.s2b n13 n15 n14 n13 = model=s2bmod

```

v.vbat n22 n19 = dc=1

```
equations {
i (n51->n50) +=iscl
iscl: v(n51,n50) = ((v(n5,n51)/(1e-9+abs(v(n5,n51)))))*((abs(v(n5,n51)*1e6/245))** 2.5)
}
}
```

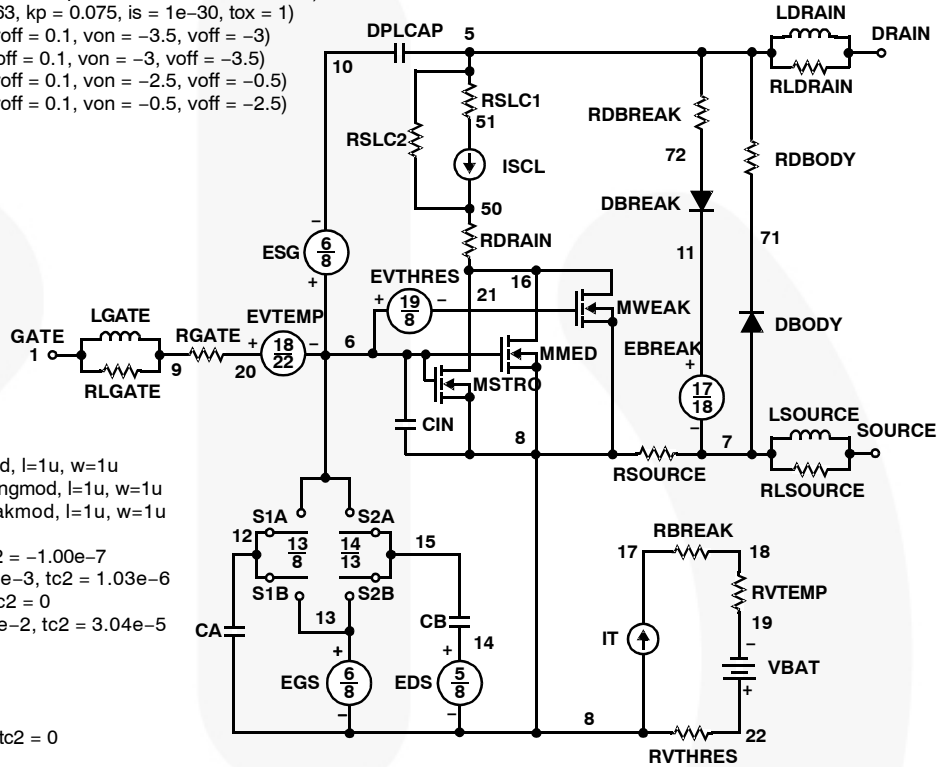

**SPICE Thermal Model**

REV 19 Oct 1999

HUF75852T

CTHERM1 th 6 9.75e-3  
 CTHERM2 6 5 3.90e-2  
 CTHERM3 5 4 2.50e-2  
 CTHERM4 4 3 2.95e-2  
 CTHERM5 3 2 6.55e-2  
 CTHERM6 2 tl 12.55

RTHERM1 th 6 1.96e-3  
 RTHERM2 6 5 4.89e-3  
 RTHERM3 5 4 1.38e-2  
 RTHERM4 4 3 7.73e-2  
 RTHERM5 3 2 1.17e-1  
 RTHERM6 2 tl 1.55e-2

**SABER Thermal Model**

SABER thermal model HUF75852T

```

template thermal_model th tl
thermal_c th, tl
{
    ctherm.ctherm1 th 6 = 9.75e-3
    ctherm.ctherm2 6 5 = 3.90e-2
    ctherm.ctherm3 5 4 = 2.50e-2
    ctherm.ctherm4 4 3 = 2.95e-2
    ctherm.ctherm5 3 2 = 6.55e-2
    ctherm.ctherm6 2 tl = 12.55

    rtherm.rtherm1 th 6 = 1.96e-3
    rtherm.rtherm2 6 5 = 4.89e-3
    rtherm.rtherm3 5 4 = 1.38e-2
    rtherm.rtherm4 4 3 = 7.73e-2
    rtherm.rtherm5 3 2 = 1.17e-1
    rtherm.rtherm6 2 tl = 1.55e-2
}
    
```

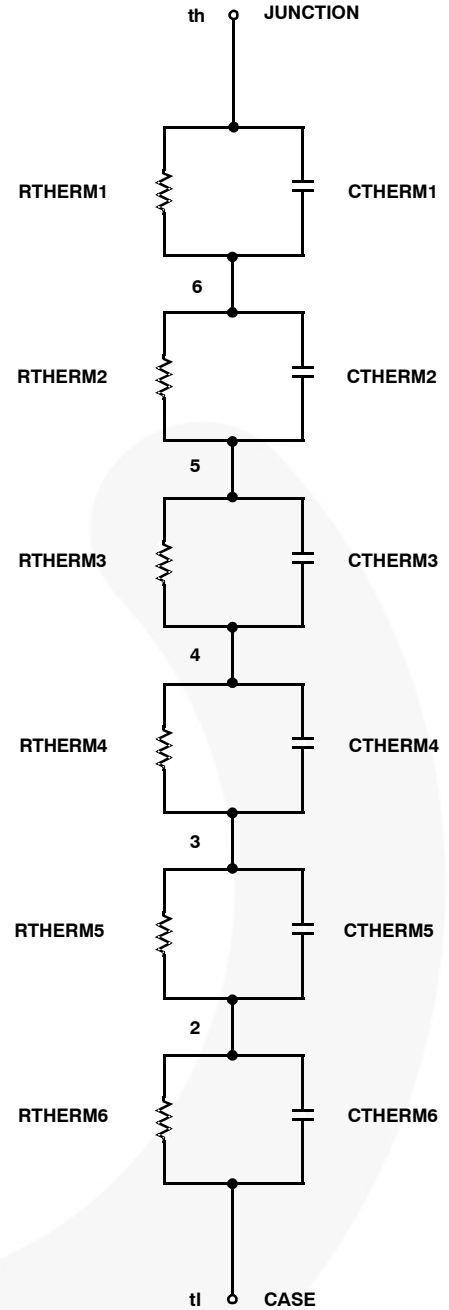

PSPICE is a trademark of MicroSim Corporation.  
 Saber is a registered trademark of Sabremark Limited Partnership.



**TO-247-3LD SHORT LEAD**  
**CASE 340CK**  
**ISSUE A**

DATE 31 JAN 2019

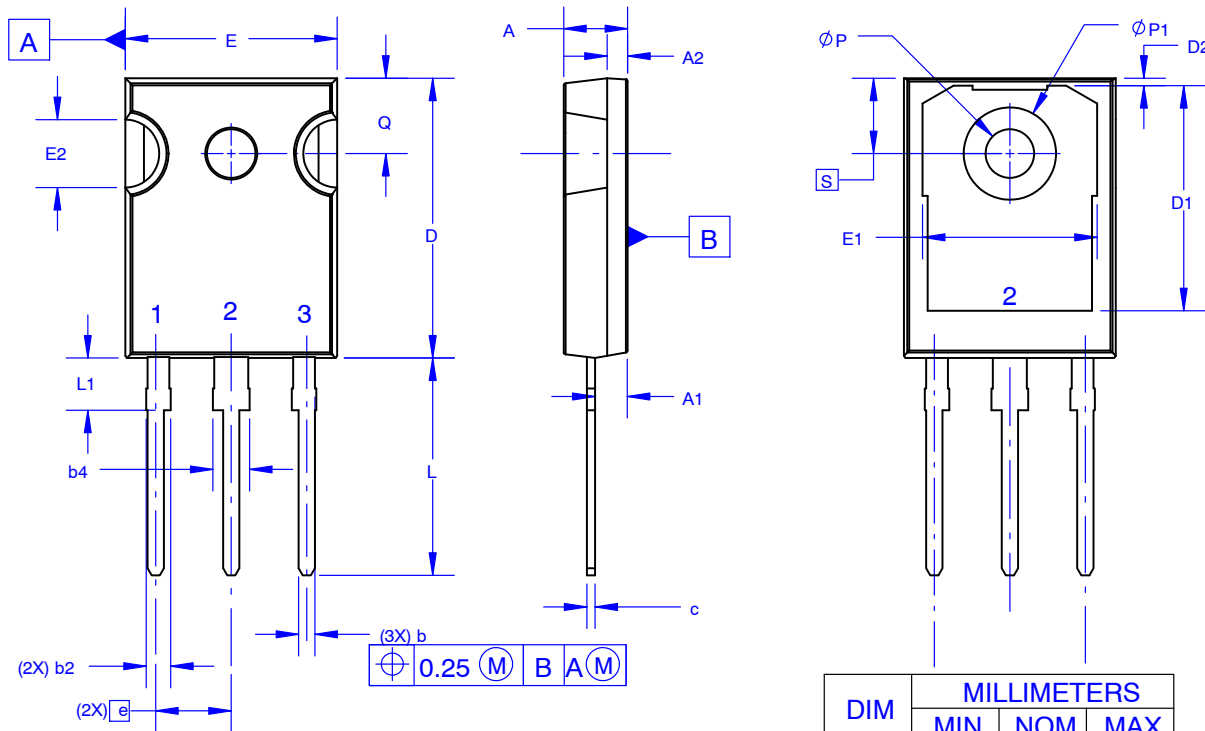

NOTES: UNLESS OTHERWISE SPECIFIED.

- A. DIMENSIONS ARE EXCLUSIVE OF BURRS, MOLD FLASH, AND TIE BAR EXTRUSIONS.
- B. ALL DIMENSIONS ARE IN MILLIMETERS.
- C. DRAWING CONFORMS TO ASME Y14.5 - 2009.
- D. DIMENSION A1 TO BE MEASURED IN THE REGION DEFINED BY L1.
- E. LEAD FINISH IS UNCONTROLLED IN THE REGION DEFINED BY L1.

**GENERIC MARKING DIAGRAM\***

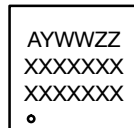

- XXXX = Specific Device Code
- A = Assembly Location
- Y = Year
- WW = Work Week
- ZZ = Assembly Lot Code

\*This information is generic. Please refer to device data sheet for actual part marking. Pb-Free indicator, "G" or microdot "•", may or may not be present. Some products may not follow the Generic Marking.

DIM	MILLIMETERS		
	MIN	NOM	MAX
A	4.58	4.70	4.82
A1	2.20	2.40	2.60
A2	1.40	1.50	1.60
b	1.17	1.26	1.35
b2	1.53	1.65	1.77
b4	2.42	2.54	2.66
c	0.51	0.61	0.71
D	20.32	20.57	20.82
D1	13.08	~	~
D2	0.51	0.93	1.35
E	15.37	15.62	15.87
E1	12.81	~	~
E2	4.96	5.08	5.20
e	~	5.56	~
L	15.75	16.00	16.25
L1	3.69	3.81	3.93
ØP	3.51	3.58	3.65
ØP1	6.60	6.80	7.00
Q	5.34	5.46	5.58
S	5.34	5.46	5.58

<b>DOCUMENT NUMBER:</b>	98AON13851G	Electronic versions are uncontrolled except when accessed directly from the Document Repository. Printed versions are uncontrolled except when stamped "CONTROLLED COPY" in red.
<b>DESCRIPTION:</b>	TO-247-3LD SHORT LEAD	<b>PAGE 1 OF 1</b>

ON Semiconductor and are trademarks of Semiconductor Components Industries, LLC dba ON Semiconductor or its subsidiaries in the United States and/or other countries. ON Semiconductor reserves the right to make changes without further notice to any products herein. ON Semiconductor makes no warranty, representation or guarantee regarding the suitability of its products for any particular purpose, nor does ON Semiconductor assume any liability arising out of the application or use of any product or circuit, and specifically disclaims any and all liability, including without limitation special, consequential or incidental damages. ON Semiconductor does not convey any license under its patent rights nor the rights of others.

**onsemi**, **Onsemi**, and other names, marks, and brands are registered and/or common law trademarks of Semiconductor Components Industries, LLC dba "**onsemi**" or its affiliates and/or subsidiaries in the United States and/or other countries. **onsemi** owns the rights to a number of patents, trademarks, copyrights, trade secrets, and other intellectual property. A listing of **onsemi**'s product/patent coverage may be accessed at [www.onsemi.com/site/pdf/Patent-Marking.pdf](http://www.onsemi.com/site/pdf/Patent-Marking.pdf). **onsemi** reserves the right to make changes at any time to any products or information herein, without notice. The information herein is provided "as-is" and **onsemi** makes no warranty, representation or guarantee regarding the accuracy of the information, product features, availability, functionality, or suitability of its products for any particular purpose, nor does **onsemi** assume any liability arising out of the application or use of any product or circuit, and specifically disclaims any and all liability, including without limitation special, consequential or incidental damages. Buyer is responsible for its products and applications using **onsemi** products, including compliance with all laws, regulations and safety requirements or standards, regardless of any support or applications information provided by **onsemi**. "Typical" parameters which may be provided in **onsemi** data sheets and/or specifications can and do vary in different applications and actual performance may vary over time. All operating parameters, including "Typicals" must be validated for each customer application by customer's technical experts. **onsemi** does not convey any license under any of its intellectual property rights nor the rights of others. **onsemi** products are not designed, intended, or authorized for use as a critical component in life support systems or any FDA Class 3 medical devices or medical devices with a same or similar classification in a foreign jurisdiction or any devices intended for implantation in the human body. Should Buyer purchase or use **onsemi** products for any such unintended or unauthorized application, Buyer shall indemnify and hold **onsemi** and its officers, employees, subsidiaries, affiliates, and distributors harmless against all claims, costs, damages, and expenses, and reasonable attorney fees arising out of, directly or indirectly, any claim of personal injury or death associated with such unintended or unauthorized use, even if such claim alleges that **onsemi** was negligent regarding the design or manufacture of the part. **onsemi** is an Equal Opportunity/Affirmative Action Employer. This literature is subject to all applicable copyright laws and is not for resale in any manner.

## PUBLICATION ORDERING INFORMATION

### LITERATURE FULFILLMENT:

Email Requests to: [orderlit@onsemi.com](mailto:orderlit@onsemi.com)

**onsemi Website:** [www.onsemi.com](http://www.onsemi.com)

### TECHNICAL SUPPORT

**North American Technical Support:**

Voice Mail: 1 800-282-9855 Toll Free USA/Canada

Phone: 011 421 33 790 2910

**Europe, Middle East and Africa Technical Support:**

Phone: 00421 33 790 2910

For additional information, please contact your local Sales Representative

## X-ON Electronics

Largest Supplier of Electrical and Electronic Components

*Click to view similar products for [MOSFET](#) category:*

*Click to view products by [ON Semiconductor](#) manufacturer:*

Other Similar products are found below :

[614233C](#) [648584F](#) [IRFD120](#) [JANTX2N5237](#) [FCA20N60\\_F109](#) [FDZ595PZ](#) [2SK2545\(Q,T\)](#) [405094E](#) [423220D](#) [TPCC8103,L1Q\(CM](#)  
[MIC4420CM-TR](#) [VN1206L](#) [SBVS138LT1G](#) [614234A](#) [715780A](#) [NTNS3166NZT5G](#) [SSM6J414TU,LF\(T](#) [751625C](#) [BUK954R8-60E](#)  
[NTE6400](#) [SQJ402EP-T1-GE3](#) [2SK2614\(TE16L1,Q\)](#) [2N7002KW-FAI](#) [DMN1017UCP3-7](#) [EFC2J004NUZTDG](#) [ECH8691-TL-W](#)  
[FCAB21350L1](#) [P85W28HP2F-7071](#) [DMN1053UCP4-7](#) [NTE221](#) [NTE222](#) [NTE2384](#) [NTE2903](#) [NTE2941](#) [NTE2945](#) [NTE2946](#) [NTE2960](#)  
[NTE2967](#) [NTE2969](#) [NTE2976](#) [NTE455](#) [NTE6400A](#) [NTE2910](#) [NTE2916](#) [NTE2956](#) [NTE2911](#) [DMN2080UCB4-7](#) [TK10A80W,S4X\(S](#)  
[SSM6P69NU,LF](#) [DMP22D4UFO-7B](#)