



ON Semiconductor®

<http://onsemi.com>

LA5744TP

Monolithic Linear IC

Separately-Excited Step-Down Switching Regulator (Variable Type)

Overview

The LA5744TP is a separately-excited step-down switching regulator (variable type).

Functions

- High efficiency.
- Time-base generator (300kHz) incorporated.
- Current limiter incorporated.
- Thermal shutdown circuit incorporated.
- Soft start circuit incorporated.

Specifications

Maximum Ratings at $T_a = 25^\circ\text{C}$

Parameter	Symbol	Conditions	Ratings	Unit
Input voltage	V_{IN}		30	V
Maximum output current	$I_O \text{ max}$		2	A
SW pin application reverse voltage	V_{SW}		-1	V
Allowable power dissipation	$P_d \text{ max}$	Mounted on a circuit board.*	1.1	W
Operating temperature	T_{opr}		-30 to +125	$^\circ\text{C}$
Storage temperature	T_{stg}		-40 to +150	$^\circ\text{C}$

* Specified circuit board : 76.1×114.3×1.6mm³, glass epoxy.

Stresses exceeding Maximum Ratings may damage the device. Maximum Ratings are stress ratings only. Functional operation above the Recommended Operating Conditions is not implied. Extended exposure to stresses above the Recommended Operating Conditions may affect device reliability.

Recommended Operating Conditions at $T_a = 25^\circ\text{C}$

Parameter	Symbol	Conditions	Ratings	Unit
Input voltage range	V_{IN}		4.5 to 28	V

LA5744TP

Electrical Characteristics at $T_a = 25^\circ\text{C}$, $V_O = 5\text{V}$

Parameter	Symbol	Conditions	Ratings			Unit
			min	typ	max	
Reference voltage	V_{OS}	$V_{IN} = 15\text{V}$, $I_O = 1.0\text{A}$	1.20	1.23	1.26	V
Efficiency	η	$V_{IN} = 15\text{V}$, $I_O = 1.0\text{A}$		83		%
Switching frequency	f	$V_{IN} = 15\text{V}$, $I_O = 1.0\text{A}$	240	300	360	kHz
Line regulation	$\Delta V_{O\text{LINE}}$	$V_{IN} = 8$ to 20V , $I_O = 1.0\text{A}$		40	100	mV
Load regulation	$\Delta V_{O\text{LOAD}}$	$V_{IN} = 20\text{V}$, $I_O = 0.5$ to 1.5A		10	30	mV
Output voltage temperature coefficient	$\Delta V_O/\Delta T_a$	Designed target value. *		± 0.5		mV/ $^\circ\text{C}$
Ripple attenuation factor	RREJ	$f = 100$ to 120Hz		45		dB
Current limiter operating voltage	I_S	$V_{IN} = 15\text{V}$	3.1			A
Thermal shutdown operating temperature	TSD	Designed target value. *		165		$^\circ\text{C}$
Thermal shutdown Hysteresis width	ΔT_{SD}	Designed target value. *		15		$^\circ\text{C}$

* Design target value : No measurement made.

Package Dimensions

unit : mm (typ)

3332

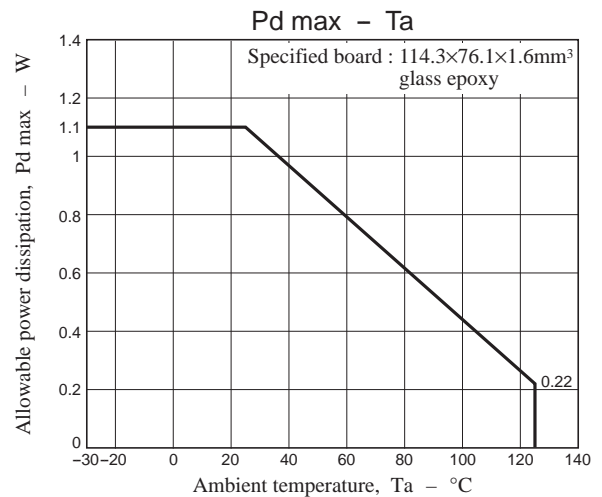
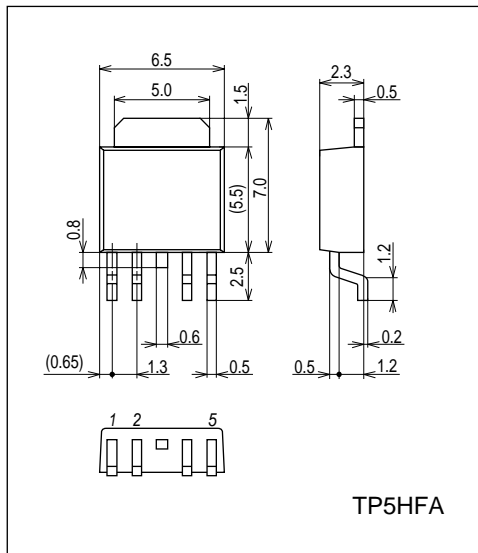

Pin Assignment

(1) V_{IN} (2) SW_{OUT} (3) GND (4) V_{OS} (5) SS

LA5744TP

Block Diagram

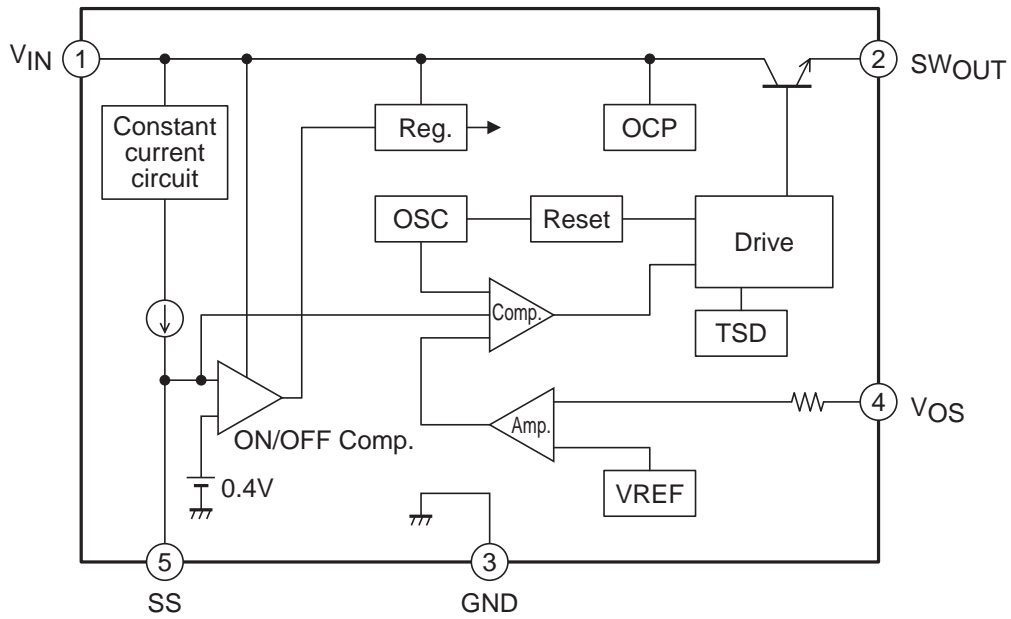

Application Circuit Example

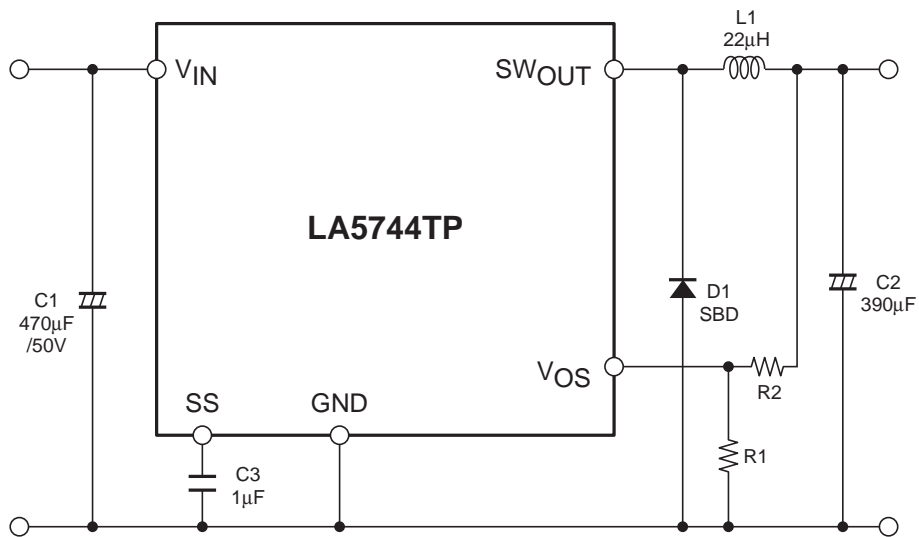

Notes :

1. C3 is for the soft start function. Delete C3 and keep the SS pin open when the soft start function is not necessary.
2. In some cases, the output may not turn on if power is applied when a load is connected. If this is a problem, increase the value of the inductor.

Protection Circuit Functional Descriptions

1. Overcurrent protection function

The overcurrent protection function detects, on a cycle-by-cycle basis, the output transistor current and turns off that output transistor current if it exceeds 3.1A.

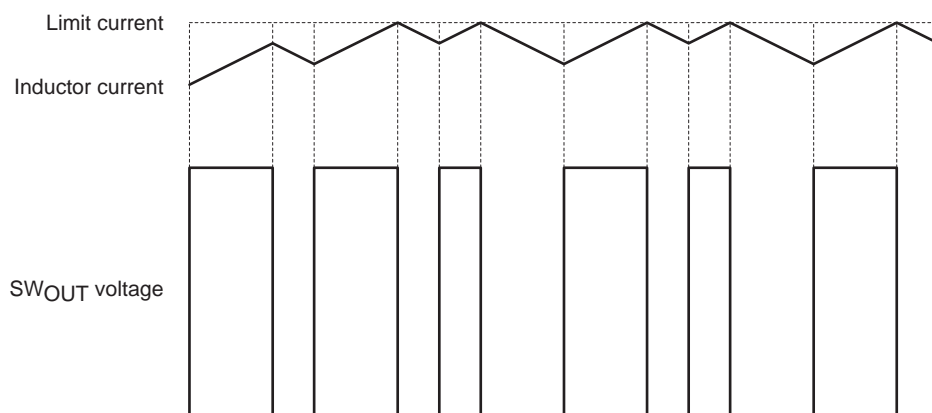

2. Short circuit protection function

This IC prevents the current from increasing when the outputs are shorted by setting the switching frequency to 30kHz if the V_{OS} pin voltage falls below 0.8V.

Note 3 : If the soft start function is not used, the IC will start up with the overcurrent protection function operating. At this time, the switching frequency will be cut in half. This means that the switching frequency will be 15kHz at startup.

Note 4 : Since the switching frequency becomes 30kHz when the V_{OS} pin voltage falls under 0.8V, the current capacity is reduced. If a load is applied with the V_{OS} pin voltage over 0.8V, the inductance value operates at 22μH. If a load is to be applied when this voltage is under 0.8V, the inductance value must be increased.

Description of Functional Settings

1. Calculation equation to set the output voltage

This IC controls the switching output so that the V_{OS} pin voltage becomes 1.23V (typ).

The equation to set the output voltage is as follows :

$$V_O = \left(1 + \frac{R_2}{R_1}\right) \times 1.23V(\text{typ})$$

The V_{OS} pin has the inrush current of 1μA (typ). Therefore, the error becomes larger when R₁ and R₂ resistance values are large.

2. Startup Delay Function

The output voltage rises when the internal voltage reaches 0.4V (typical). Until that point, a capacitor is charged from an internal 10μA (typical) constant-current supply. The startup delay time can be calculated as shown below

Example : Assume a 1μF capacitor is used.

$$T_d = \frac{C \times V}{i} = \frac{1\mu F \times 0.4}{10\mu A} = 40 \text{ ms}$$

Timing Chart

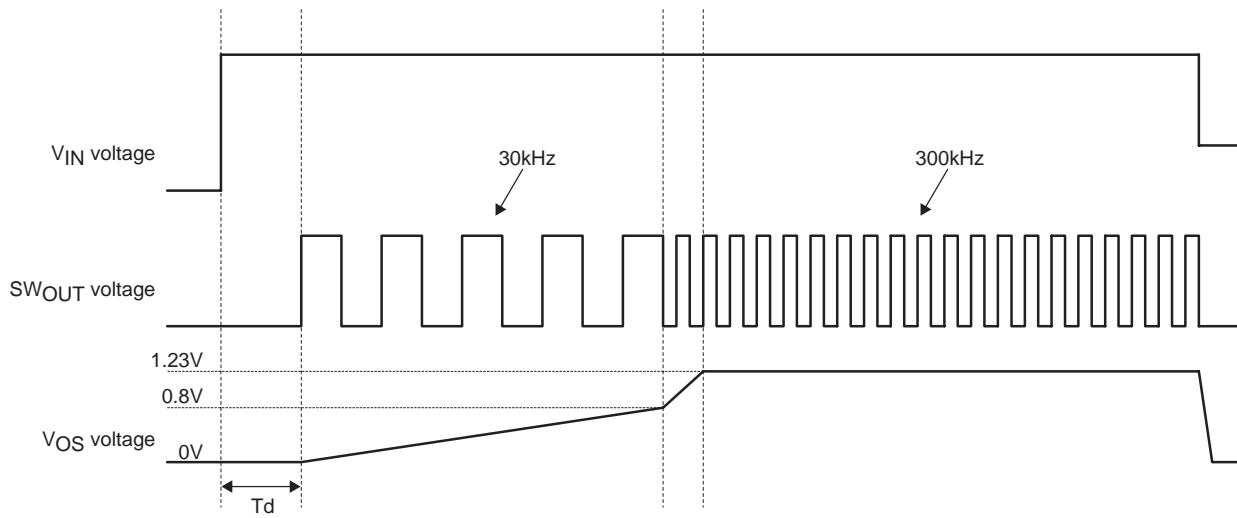

ON Semiconductor and the ON logo are registered trademarks of Semiconductor Components Industries, LLC (SCILLC). SCILLC owns the rights to a number of patents, trademarks, copyrights, trade secrets, and other intellectual property. A listing of SCILLC's product/patent coverage may be accessed at www.onsemi.com/site/pdf/Patent-Marking.pdf. SCILLC reserves the right to make changes without further notice to any products herein. SCILLC makes no warranty, representation or guarantee regarding the suitability of its products for any particular purpose, nor does SCILLC assume any liability arising out of the application or use of any product or circuit, and specifically disclaims any and all liability, including without limitation special, consequential or incidental damages. "Typical" parameters which may be provided in SCILLC data sheets and/or specifications can and do vary in different applications and actual performance may vary over time. All operating parameters, including "Typicals" must be validated for each customer application by customer's technical experts. SCILLC does not convey any license under its patent rights nor the rights of others. SCILLC products are not designed, intended, or authorized for use as components in systems intended for surgical implant into the body, or other applications intended to support or sustain life, or for any other application in which the failure of the SCILLC product could create a situation where personal injury or death may occur. Should Buyer purchase or use SCILLC products for any such unintended or unauthorized application, Buyer shall indemnify and hold SCILLC and its officers, employees, subsidiaries, affiliates, and distributors harmless against all claims, costs, damages, and expenses, and reasonable attorney fees arising out of, directly or indirectly, any claim of personal injury or death associated with such unintended or unauthorized use, even if such claim alleges that SCILLC was negligent regarding the design or manufacture of the part. SCILLC is an Equal Opportunity/Affirmative Action Employer. This literature is subject to all applicable copyright laws and is not for resale in any manner.

X-ON Electronics

Largest Supplier of Electrical and Electronic Components

Click to view similar products for [Switching Voltage Regulators](#) category:

Click to view products by [ON Semiconductor](#) manufacturer:

Other Similar products are found below :

[FAN53610AUC33X](#) [FAN53611AUC123X](#) [FAN48610BUC33X](#) [FAN48610BUC45X](#) [FAN48617UC50X](#) [R3](#) [430464BB](#) [KE177614](#)
[MAX809TTR](#) [NCV891234MW50R2G](#) [NCP81103MNTXG](#) [NCP81203PMNTXG](#) [NCP81208MNTXG](#) [NCP81109GMNTXG](#)
[SCY1751FCCT1G](#) [NCP81109JMNTXG](#) [AP3409ADNTR-G1](#) [NCP81241MNTXG](#) [LTM8064IY](#) [LT8315EFE#TRPBF](#) [NCV1077CSTBT3G](#)
[XCL207A123CR-G](#) [MPM54304GMN-0002](#) [MPM54304GMN-0003](#) [XDPE132G5CG000XUMA1](#) [MP8757GL-P](#) [MIC23356YFT-TR](#)
[LD8116CGL](#) [HG2269M/TR](#) [OB2269](#) [XD3526](#) [U6215A](#) [U6215B](#) [U6620S](#) [LTC3803ES6#TR](#) [LTC3803ES6#TRM](#) [LTC3412IFE](#) [LT1425IS](#)
[MAX25203BATJA/VY+](#) [MAX77874CEWM+](#) [XC9236D08CER-G](#) [ISL95338IRTZ](#) [MP3416GJ-P](#) [BD9S201NUX-CE2](#) [MP5461GC-Z](#)
[MPQ4415AGQB-Z](#) [MPQ4590GS-Z](#) [MCP1603-330IMC](#) [MCP1642B-18IMC](#) [MCP1642D-ADJIMC](#)