



ON Semiconductor®

<http://onsemi.com>

# LA5771MP

Monolithic Linear IC

## Separately-excited Step-down Switching Regulator (3.3V)

### Overview

The LA5771MP is a separately-excited step-down switching regulator (3.3V).

### Features

- High efficiency
- Four external parts
- Time-base generator (160kHz) incorporated
- Current limiter incorporated
- Thermal shutdown circuit incorporated
- Soft start circuit incorporated

### Specifications

#### Absolute Maximum Ratings at $T_a = 25^\circ\text{C}$

Parameter	Symbol	Conditions	Ratings	Unit
Input voltage	$V_{IN\ max}$		30	V
Output current	$I_O\ max$		3	A
SW pin application reverse voltage	$V_{sw}$		-1	V
Allowable power dissipation	$P_d\ max$	Mounted on the specified board *	3.9	W
Operating temperature	$T_{opr}$		-30 to +125	$^\circ\text{C}$
Storage temperature	$T_{stg}$		-40 to +150	$^\circ\text{C}$

\* Mounted on a specified board: 114.3mm×76.1mm×1.6mm, Copper foil ratio 60% FR4

Stresses exceeding Maximum Ratings may damage the device. Maximum Ratings are stress ratings only. Functional operation above the Recommended Operating Conditions is not implied. Extended exposure to stresses above the Recommended Operating Conditions may affect device reliability.

#### Recommended Operating Conditions at $T_a = 25^\circ\text{C}$

Parameter	Symbol	Conditions	Ratings	Unit
Input voltage range	$V_{IN}$		5.5 to 28	V

# LA5771MP

## Electrical Characteristics at Ta = 25°C

Parameter	Symbol	Conditions	Ratings			Unit
			min	typ	max	
Output voltage	$V_O$	$V_{IN}=15V, I_O=1.0A$	3.17	3.30	3.43	V
Efficiency	$\eta$	$V_{IN}=15V, I_O=1.0A$		79		%
Switching frequency	f	$V_{IN}=15V, I_O=1.0A$	128	160	192	kHz
Line regulation	$\Delta V_{OLINE}$	$V_{IN}=8 \text{ to } 20V, I_O=1.0A$		25	80	mV
Load regulation	$\Delta V_{OLOAD}$	$V_{IN}=15V, I_O=0.5 \text{ to } 1.5A$		10	30	mV
Output voltage temperature coefficient	$\Delta V_O/\Delta T_a$	Designed target value*		$\pm 0.5$		mV/°C
Ripple attenuation factor	RREJ	F=100 to 120Hz		45		dB
Current limiter operating voltage	IS	$V_{IN}=15V$	3.1			A
Thermal shutdown operating temperature	TSD	Designed target value*		165		°C
Thermal shutdown hysteresis width	$\Delta TSD$	Designed target value*		15		°C

\* Designed target value: No measurement made.

## Package Dimensions

unit : mm (typ)

3275

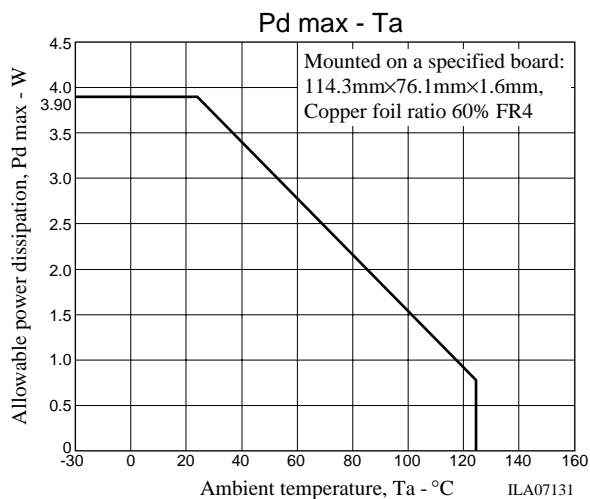
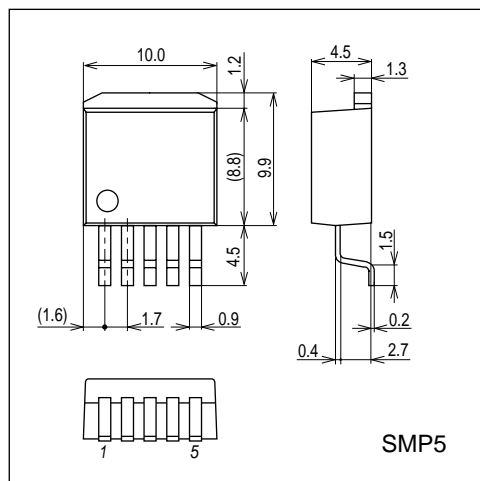

## Pin Assignment

①VIN ②SWOUT ③GND ④VOS ⑤SS

# LA5771MP

## Block Diagram

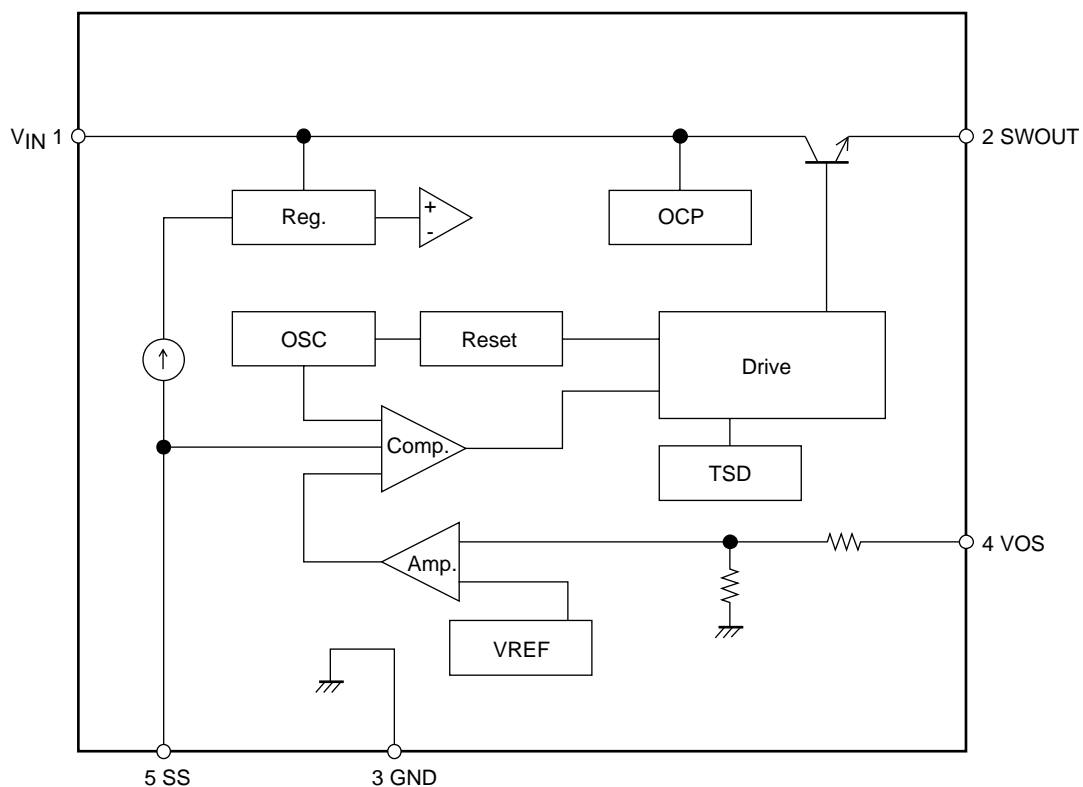

## Application Circuit Example

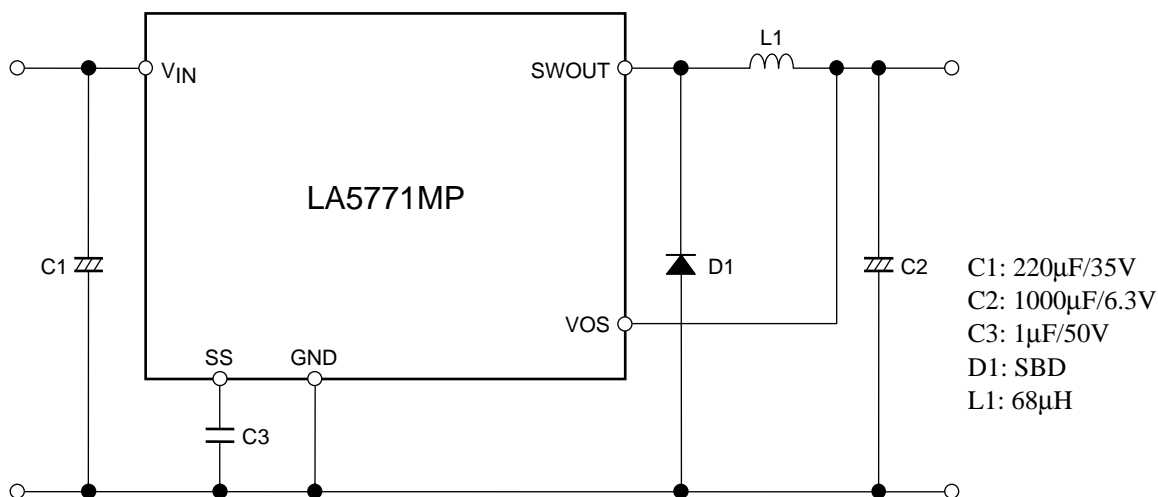

Notes: C3 is for the soft start function. Delete C3 and keep the SS pin open when the soft function is not necessary.

## Description of Functional Settings

### 1. Start delay function

The SS pin has the internally-connected 22μA (typ) constant-current supply. When the voltage of SS pin exceeds the threshold voltage, the regulator starts operation. As the threshold is 0.62V(typ), the start delay time can be calculated as follows:

ex. For setting at 1μF

$$T_d = \frac{C \times V}{i} = \frac{1\mu\text{A} \times 0.62\text{V}}{22\mu\text{A}} = 28.2\text{ms}$$

### 2. Soft start function

The internal PWM waveform has the voltage value as shown in the right.

If down-conversion from the voltage of  $V_{IN}=15\text{V}$  to 3.3V output is to be made, for example, the PWM-ON duty has the value as shown below.

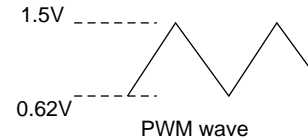

$$\text{PWMduty} = \frac{V_{\text{OUT}}}{V_{\text{IN}} - V_{\text{sat}} + V_{\text{F}}} = 23\%$$

(Note that calculation is made with  $V_{\text{sat}}=1\text{V}$  and  $V_{\text{F}}=0.2\text{V}$ )

The output voltage of error amplifier, which is 3.3V, is the value with PWM=23%, as calculated in the above equation, so that this voltage is determined as follows:

$$V_{\text{er}} = (\Delta V_{\text{PWM}}) \times \text{PWMduty} + V_{\text{PWML}} = 0.88\text{V} \times 0.23 + 0.62\text{V} = 0.82\text{V}$$

( $\Delta V_{\text{PWM}}$  is the PWM amplitude value or 0.88V(typ) while  $V_{\text{PWML}}$  is the lower limit voltage of PWM waveform or 0.62V(typ))

SS pin and error amplifier output voltages are designed to prefer the lower voltages, so that  $V_{\text{OUT}}$  will reach the designed regulation voltage in timing when the SS pin voltage exceeds the error amplifier output. Therefore, the soft start time is calculated as follows:

$$T_{\text{ss}} = \frac{C \times \Delta V_{\text{PWM}} \times \text{PWMduty}}{i} = \frac{C \times 0.88\text{V} \times \text{PWMduty}}{22\mu\text{A}}$$

For the set conditions of  $C=1\mu\text{F}$  and  $\text{PWMduty}=23\%$ :

$$T_{\text{ss}} = \frac{1\mu\text{A} \times 0.88\text{V} \times 0.23}{22\mu\text{A}} = 9.2\text{ms}$$

## Timing Chart

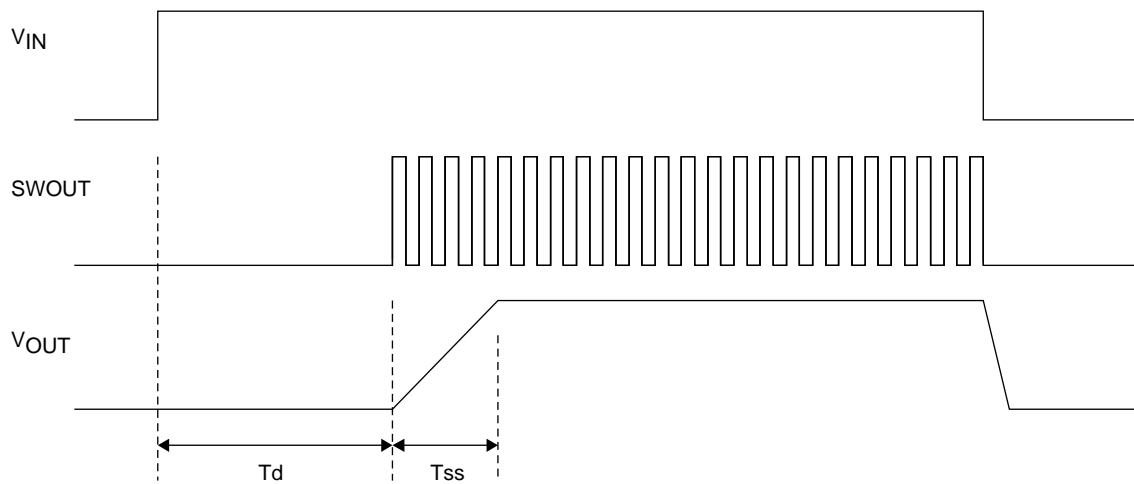

ON Semiconductor and the ON logo are registered trademarks of Semiconductor Components Industries, LLC (SCILLC). SCILLC owns the rights to a number of patents, trademarks, copyrights, trade secrets, and other intellectual property. A listing of SCILLC's product/patent coverage may be accessed at [www.onsemi.com/site/pdf/Patent-Marking.pdf](http://www.onsemi.com/site/pdf/Patent-Marking.pdf). SCILLC reserves the right to make changes without further notice to any products herein. SCILLC makes no warranty, representation or guarantee regarding the suitability of its products for any particular purpose, nor does SCILLC assume any liability arising out of the application or use of any product or circuit, and specifically disclaims any and all liability, including without limitation special, consequential or incidental damages. "Typical" parameters which may be provided in SCILLC data sheets and/or specifications can and do vary in different applications and actual performance may vary over time. All operating parameters, including "Typicals" must be validated for each customer application by customer's technical experts. SCILLC does not convey any license under its patent rights nor the rights of others. SCILLC products are not designed, intended, or authorized for use as components in systems intended for surgical implant into the body, or other applications intended to support or sustain life, or for any other application in which the failure of the SCILLC product could create a situation where personal injury or death may occur. Should Buyer purchase or use SCILLC products for any such unintended or unauthorized application, Buyer shall indemnify and hold SCILLC and its officers, employees, subsidiaries, affiliates, and distributors harmless against all claims, costs, damages, and expenses, and reasonable attorney fees arising out of, directly or indirectly, any claim of personal injury or death associated with such unintended or unauthorized use, even if such claim alleges that SCILLC was negligent regarding the design or manufacture of the part. SCILLC is an Equal Opportunity/Affirmative Action Employer. This literature is subject to all applicable copyright laws and is not for resale in any manner.

## X-ON Electronics

Largest Supplier of Electrical and Electronic Components

*Click to view similar products for [Switching Voltage Regulators](#) category:*

*Click to view products by [ON Semiconductor](#) manufacturer:*

Other Similar products are found below :

[FAN53610AUC33X](#) [FAN53611AUC123X](#) [FAN48610BUC33X](#) [FAN48610BUC45X](#) [FAN48617UC50X](#) [R3](#) [430464BB](#) [KE177614](#)  
[MAX809TTR](#) [NCV891234MW50R2G](#) [NCP81103MNTXG](#) [NCP81203PMNTXG](#) [NCP81208MNTXG](#) [NCP81109GMNTXG](#)  
[SCY1751FCCT1G](#) [NCP81109JMNTXG](#) [AP3409ADNTR-G1](#) [NCP81241MNTXG](#) [LTM8064IY](#) [LT8315EFE#TRPBF](#) [LTM4668AIY#PBF](#)  
[NCV1077CSTBT3G](#) [XCL207A123CR-G](#) [MPM54304GMN-0002](#) [MPM54304GMN-0003](#) [XDPE132G5CG000XUMA1](#) [MP8757GL-P](#)  
[MIC23356YFT-TR](#) [LD8116CGL](#) [HG2269M/TR](#) [OB2269](#) [XD3526](#) [U6215A](#) [U6215B](#) [U6620S](#) [LTC3803ES6#TR](#) [LTC3803ES6#TRM](#)  
[LTC3412IFE](#) [LT1425IS](#) [MAX25203BATJA/VY+](#) [MAX77874CEWM+](#) [XC9236D08CER-G](#) [ISL95338IRTZ](#) [MP3416GJ-P](#) [BD9S201NUX-](#)  
[CE2](#) [MP5461GC-Z](#) [MPQ4415AGQB-Z](#) [MPQ4590GS-Z](#) [MCP1603-330IMC](#) [MCP1642B-18IMC](#)