



ON Semiconductor®

<http://onsemi.com>

# LB11620T

## Monolithic Digital IC Brushless Motor Driver

### Overview

The LB11620T is a direct PWM drive predriver IC that is optimal for three-phase power brushless motors. A motor driver circuit with the desired output capability (voltage and current) can be implemented by adding discrete transistors or other power devices to the outputs of this IC. Since the LB11620T is provided in a miniature package, it is also appropriate for use with miniature motors as well.

### Features

- Three-phase bipolar drive
- Direct PWM drive (input of either a control voltage or a variable-duty PWM signal)
- Built-in forward/reverse switching circuit
- Full complement of protection circuits (current limiter, low-voltage, and automatic recovery lock (motor constraint) protection circuits)
- Selectable Hall sensor signal pulse output

### Specifications

#### Maximum Ratings at $T_a = 25^\circ\text{C}$

Parameter	Symbol	Conditions	Ratings	Unit
Supply voltage 1	$V_{CC}$ max	$V_{CC}$ pin	18	V
Output current	$I_O$ max	UL, VL, WL, UH, VH, WH pins	30	mA
Allowable power dissipation	$P_d$ max	*Mounted on a circuit board.	0.8	W
Operating temperature	$T_{opr}$		-20 to +100	$^\circ\text{C}$
Storage temperature	$T_{stg}$		-55 to +150	$^\circ\text{C}$

\* Mounted on a circuit board : 114.3mm×76.1mm×1.6mm, glass epoxy board.

Stresses exceeding Maximum Ratings may damage the device. Maximum Ratings are stress ratings only. Functional operation above the Recommended Operating Conditions is not implied. Extended exposure to stresses above the Recommended Operating Conditions may affect device reliability.

# LB11620T

## Recommended Operating Ranges at $T_a = 25^\circ\text{C}$

Parameter	Symbol	Conditions	Ratings	Unit
Supply voltage range 1-1	$V_{CC1-1}$	$V_{CC}$ pin	8 to 17	V
Supply voltage range 1-2	$V_{CC1-2}$	$V_{CC}$ pin, with $V_{CC}$ shorted to VREG	4.5 to 5.5	V
Output current	$I_O$	UL, VL, WL, UH, VH, WH pins	25	mA
5 V constant voltage output current	IREG		-30	mA
HP pin voltage	VHP		0 to 17	V
HP pin output current	IHP		0 to 15	mA
RD pin voltage	VRD		0 to 17	V
RD pin output current	IRD		0 to 15	mA

## Electrical Characteristics at $T_a = 25^\circ\text{C}$ , $V_{CC} = 12\text{V}$

Parameter	Symbol	Conditions	Ratings			Unit
			min	typ	max	
Supply voltage 1	$I_{CC1}$			12	16	mA
<b>5V constant voltage output (VREG pin)</b>						
Output voltage	VREG		4.7	5.0	5.3	V
Line regulation	$\Delta V_{REG1}$	$V_{CC} = 8$ to $17\text{V}$		40	100	mV
Load regulation	$\Delta V_{REG2}$	$I_O = -5$ to $-20\text{mA}$		10	30	mV
Temperature coefficient	$\Delta V_{REG3}$	Design target		0		mV/ $^\circ\text{C}$
<b>Low-voltage protection circuit (VREG pin)</b>						
Operating voltage	VSDL		3.5	3.7	3.9	V
Clear voltage	VSDH		3.95	4.15	4.35	V
Hysteresis	$\Delta V_{SD}$		0.3	0.45	0.6	V
<b>Output Block</b>						
Output voltage 1-1	$V_{OUT1-1}$	Low level $I_O = 400\mu\text{A}$		0.2	0.5	V
Output voltage 1-2	$V_{OUT1-2}$	Low level $I_O = 10\text{mA}$		0.9	1.2	V
Output voltage 2	$V_{OUT2}$	High level $I_O = -20\text{mA}$	$V_{CC-1.1}$	$V_{CC-0.9}$		V
Output leakage current	$I_{Oleak}$				10	$\mu\text{A}$
<b>Hall Amplifier Block</b>						
Input bias current	IHB (HA)		-2	-0.5		$\mu\text{A}$
Common-mode input voltage range 1	VICM1	When a Hall effect sensor is used	0.5		$V_{CC-2.0}$	V
Common-mode input voltage range 2	VICM2	For single-sided input bias (Hall IC application)	0		$V_{CC}$	V
Hall input sensitivity			80			mVp-p
Hysteresis	$\Delta V_{IN}$ (HA)		15	24	40	mV
Input voltage low $\rightarrow$ high	VSLH (HA)		5	12	20	mV
Input voltage high $\rightarrow$ low	VSHL (HA)		-20	-12	-5	mV
<b>PWM Oscillator (PWM pin)</b>						
High-level output voltage	$V_{OH}$ (PWM)		2.75	3.0	3.25	V
Low-level output voltage	$V_{OL}$ (PWM)		1.2	1.35	1.5	V
External capacitor charge current	ICHG	$V_{PWM} = 2.1\text{V}$	-120	-90	-65	$\mu\text{A}$
Oscillator frequency	f (PWM)	$C = 2000\text{pF}$		22		kHz
Amplitude	V (PWM)		1.4	1.6	1.9	Vp-p

Continued on next page

# LB11620T

Continued from preceding page.

Parameter	Symbol	Conditions	Ratings			Unit
			min	typ	max	
<b>EI+ pin</b>						
Input bias current	IB (CTL)		-1		1	μA
Common-mode input voltage range	VICM		0		VREG-1.7	V
Input voltage 1	VCTL1	Output duty 100%		3.0		V
Input voltage 2	VCTL2	Output duty 0%		1.35		V
Input voltage 1L	VCTL1L	Design target value. When VREG = 4.7V, 100%		2.82		V
Input voltage 2L	VCTL2L	Design target value. When VREG = 4.7V, 0%		1.29		V
Input voltage 1H	VCTL1H	Design target value. When VREG = 5.3V, 100%		3.18		V
Input voltage 2H	VCTL2H	Design target value. When VREG = 5.3V, 0%		1.44		V
<b>HP pin</b>						
Output saturation voltage	VHPL	I <sub>O</sub> = 10mA		0.2	0.5	V
Output leakage current	IHPleak	V <sub>O</sub> = 18V			10	μA
<b>CSD oscillator (CSD pin)</b>						
High-level output voltage	V <sub>OH</sub> (CSD)		2.7	3.0	3.3	V
Low-level output voltage	V <sub>OL</sub> (CSD)		0.7	1.0	1.3	V
External capacitor charge current	ICHG1	VCSD = 2V	-3.15	-2.5	-1.85	μA
External capacitor discharge current	ICHG2	VCSD = 2V	0.1	0.14	0.18	μA
Charge/discharge current ratio	RCSD	Charge current /discharge current	15	18	21	Times
<b>RD pin</b>						
Low-level output voltage	VRDL	I <sub>O</sub> = 10mA		0.2	0.5	V
Output leakage current	IL (RD)	V <sub>O</sub> = 18V			10	μA
<b>Current limiter circuit (RF pin)</b>						
Limiter voltage	VRF	RF-GND	0.225	0.25	0.275	V
<b>PWMIN pin</b>						
Input frequency	f (PI)				50	kHz
High-level input voltage	V <sub>IH</sub> (PI)		2.0		VREG	V
Low-level input voltage	V <sub>IL</sub> (PI)		0		1.0	V
Input open voltage	V <sub>IO</sub> (PI)		VREG-0.5		VREG	V
Hysteresis	V <sub>IS</sub> (PI)		0.2	0.25	0.4	V
High-level input current	I <sub>IH</sub> (PI)	VPWMIN = VREG	-10	0	10	μA
Low-level input current	I <sub>IL</sub> (PI)	VPWMIN = 0V	-130	-90		μA
<b>F/R pin</b>						
High-level input voltage	V <sub>IH</sub> (FR)		2.0		VREG	V
Low-level input voltage	V <sub>IL</sub> (FR)		0		1.0	V
Input open voltage	V <sub>IO</sub> (FR)		VREG-0.5		VREG	V
Hysteresis	V <sub>IS</sub> (FR)		0.2	0.25	0.4	V
High-level input current	I <sub>IH</sub> (FR)		-10	0	10	μA
Low-level input current	I <sub>IL</sub> (FR)		-130	-90		μA
<b>N1 pin</b>						
High-level input voltage	V <sub>IH</sub> (N1)		2.0		VREG	V
Low-level input voltage	V <sub>IL</sub> (N1)		0		1.0	V
Input open voltage	V <sub>IO</sub> (N1)		VREG-0.5		VREG	V
High-level input current	I <sub>IH</sub> (N1)	VN1 = VREG	-10	0	10	μA
Low-level input current	I <sub>IL</sub> (N1)	VN1 = 0V	-130	-100		μA

# LB11620T

## Package Dimensions

unit : mm (typ)  
3260A

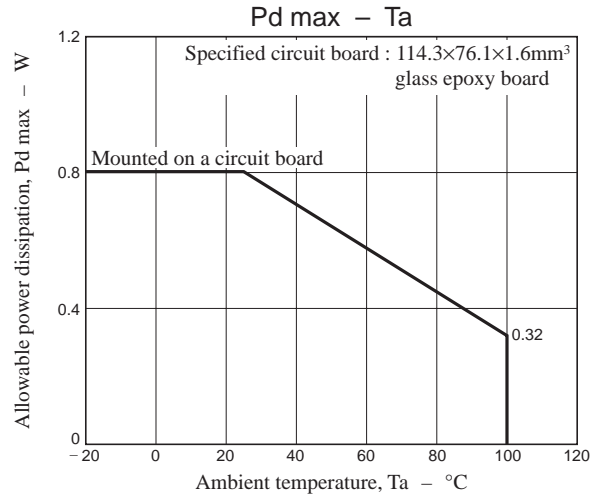
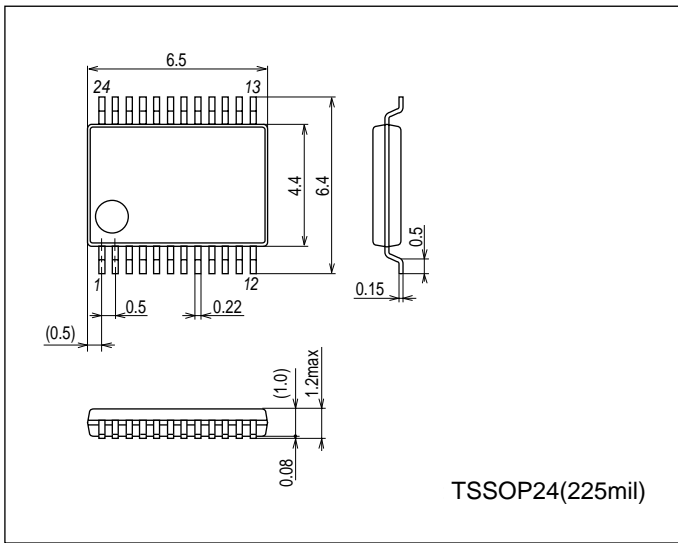

## Pin Assignment

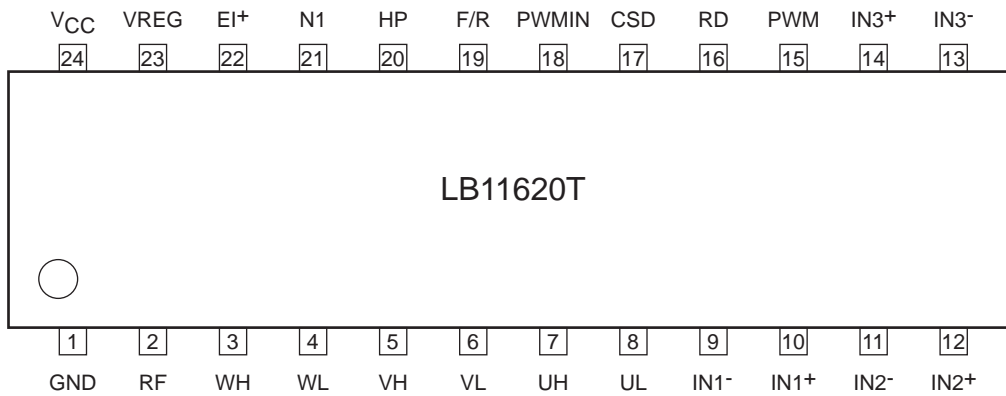

### • Three-Phase Logic Truth Table (IN = "H" indicates the state where IN+ > IN-)

	F/R = "L"			F/R = "H"			Output	
	IN1	IN2	IN3	IN1	IN2	IN3	PWM	
1	H	L	H	L	H	L	VH	UL
2	H	L	L	L	H	H	WH	UL
3	H	H	L	L	L	H	WH	VL
4	L	H	L	H	L	H	UH	VL
5	L	H	H	H	L	L	UH	WL
6	L	L	H	H	H	L	VH	WL

### • PWMIN pin

Input state	State
High or open	Output off
Low	Output on

If the PWM pin is not used, the input must be held at the low level.

### • N1 pin

Input state	HP output
High or open	Three Hall sensor synthesized output
Low	Single Hall sensor output

# LB11620T

## Pin Functions

Pin No.	Pin	Description
1	GND	Ground
2	RF	Output current detection. The current detection resistor (Rf) voltage is sensed by the RF pin to implement current detection. The maximum output current is set by RF to be $I_{OUT} = 0.25/R_f$ .
7 5 3	UH VH WH	Outputs (PWM outputs). These are push-pull outputs.
8 6 4	UL VL WL	Outputs These are push-pull outputs.
10, 9 12, 11 14, 13	IN1+, IN1- IN2+, IN2- IN3+, IN3-	Hall sensor inputs from each motor phase. The logic high state indicates that $IN^+ > IN^-$ . If inputs are provided by a Hall effect sensor IC, the common-mode input range is expanded by biasing either the + or - input.
15	PWM	Functions as both the PWM oscillator frequency setting pin and the initial reset pulse setting pin. Connect a capacitor between this pin and ground.
16	RD	Lock (motor constrained) detection state output. This output is turned on when the motor is turning and off when the lock protection function detects that the motor has been stopped. This is an open collector output.
17	CSD	Sets the operating time for the lock protection circuit. Connect a capacitor between this pin and ground. Connect this pin to ground if the lock protection function is not used.
18	PWMIN	PWM pulse signal input. The output goes to the drive state when this pin is low, and to the off state when this pin is high or open. To use this pin for control, a CTL amplifier input such that the TOC pin voltage goes to the 100% duty state must be provided.
19	F/R	Forward/reverse control input
20	HP	Hall signal output (HP output). This provides either a single Hall sensor output or a synthesized 3-sensor output.
21	N1	Hall signal output (HP output) selection
22	EI+	CTL amplifier + (noninverting) input. The PWMIN pin must be held at the low level to use this input for motor control
23	VREG	5V regulator output (Used as the control circuit power supply. A low-voltage protection circuit is built in.) Connect a capacitor between this pin and ground for stabilization.
24	VCC	Power supply. Connect a capacitor between this pin and ground to prevent noise and other disturbances from affecting this IC.

# LB11620T

## Hall Sensor Signal Input/Output Timing Chart

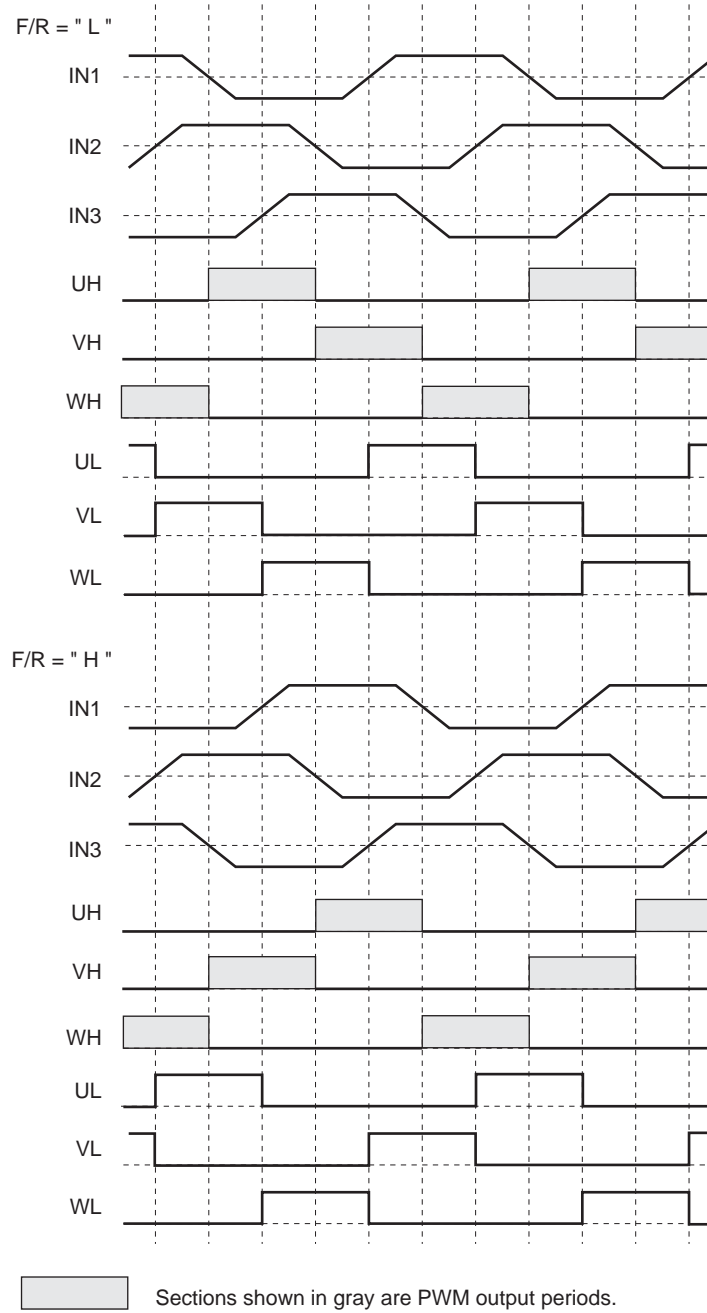



**Application Example 2**

54 MOS transistor drive (low side PWM)  
using a 12V single-voltage power supply

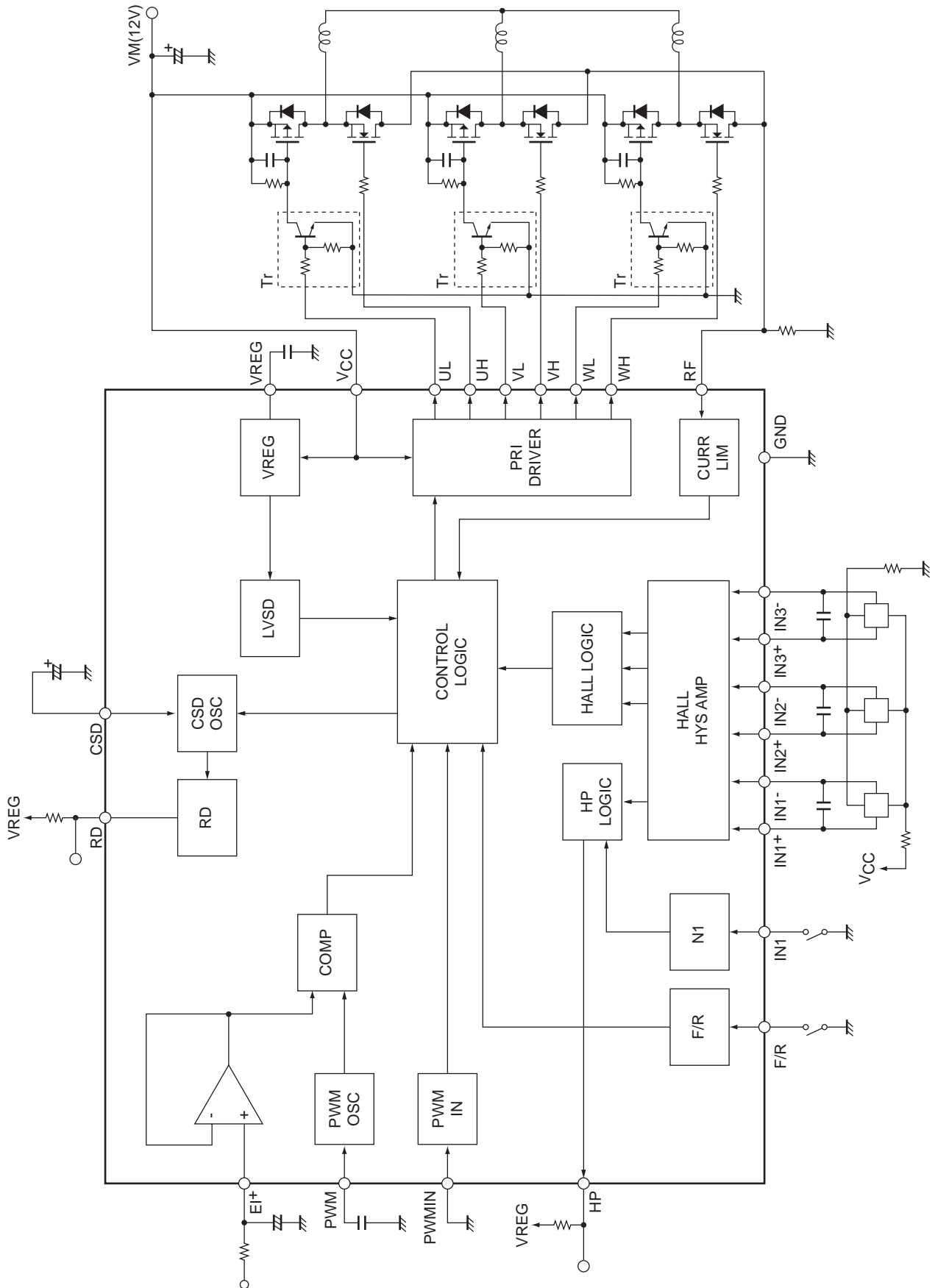



**Application Example 3**

MOS transistor drive (low side PWM)  
 using a  $V_{CC} = 12V$ ,  $V_M = 24V$  power supply system

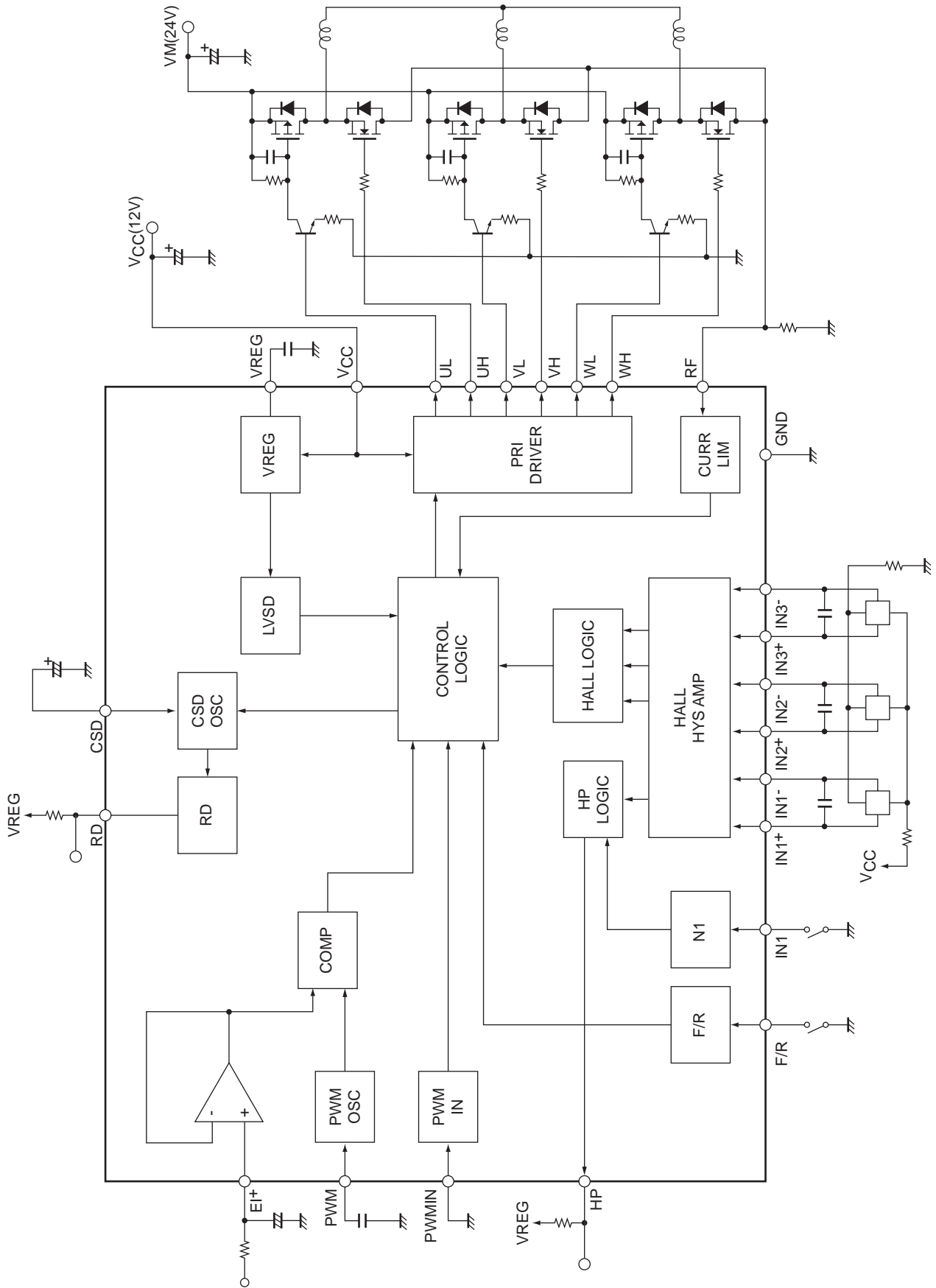

**Application Example 4**

MOS transistor drive (low side PWM)  
using a 24V single-voltage power supply

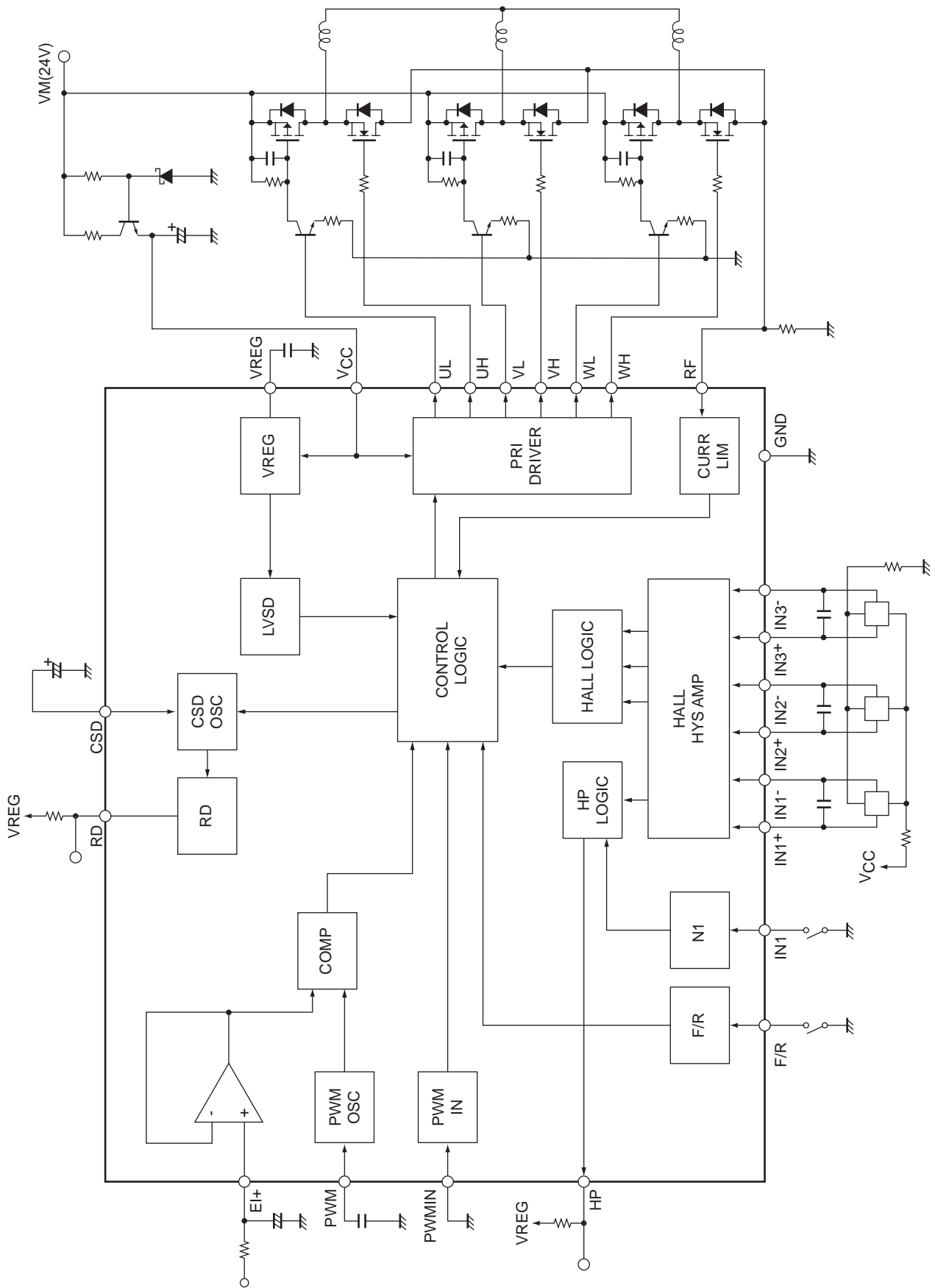

## LB11620T Functional Description

### 1. Output Drive Circuit

The LB11620T adopts direct PWM drive to minimize power loss in the outputs. The output transistors are always saturated when on, and the motor drive power is adjusted by changing the on duty of the output. The output PWM switching is performed on the UH, VH, and WH outputs. Since the UL to WL and UH to WH outputs have the same output form, applications can select either low side PWM or high side PWM drive by changing the way the external output transistors are connected. Since the reverse recovery time of the diodes connected to the non-PWM side of the outputs is a problem, these devices must be selected with care. (This is because through currents will flow at the instant the PWM side transistors turn on if diodes with a short reverse recovery time are not used.)

### 2. Current Limiter Circuit

The current limiter circuit limits the output current peak value to a level determined by the equation  $I = VFR/R_f$  ( $VFR = 0.25V$  typical,  $R_f$ : current detection resistor). This circuit suppresses the output current by reducing the output on duty.

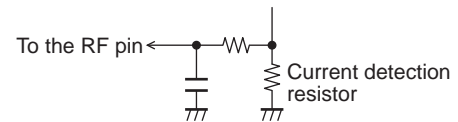

The current limiter circuit includes an internal filter circuit to prevent incorrect current limiter circuit operation due to detecting the output diode reverse recovery current due to PWM operation. Although there should be no problems with the internal filter circuit in normal applications, applications should add an external filter circuit (such as an RC low-pass filter) if incorrect operation occurs (if the diode reverse recovery current flows for longer than  $1\mu s$ ).

### 3. Notes on the PWM Frequency

The PWM frequency is determined by the capacitor C (F) connected to the PWM pin.

$$f_{PWM} \approx 1/(22500 \times C)$$

If a 2000pF capacitor is used, the circuit will oscillate at about 22kHz. If the PWM frequency is too low, switching noise will be audible from the motor, and if it is too high, the output power loss will increase. Thus a frequency in the range 15k to 50kHz must be used. The capacitor's ground terminal must be placed as close as possible to the IC's ground pin to minimize the influence of output noise and other noise sources.

### 4. Control Methods

The output duty can be controlled by either of the following methods

- Control based on comparing the EI+ pin voltage to the PWM oscillator waveform

The low side output transistor duty is determined according to the result of comparing the EI+ pin voltage to the PWM oscillator waveform. When the EI+ pin voltage is 1.35V or lower, the duty will be 0%, and when it is 3.0V or higher, the duty will be 100%.

When EI+ pin voltage control is used, a low-level input must be applied to the PWMIN pin or that pin connected to ground.

- Pulse Control Using the PWMIN Pin

A pulse signal can be input to the PWMIN pin, and the output can be controlled based on the duty of that signal.

Note that the output is on when a low level is input to the PWMIN pin, and off when a high level is input. When the PWMIN pin is open it goes to the high level and the output is turned off. If inverted input logic is required, this can be implemented with an external transistor (npn).

When controlling motor operation from the PWMIN pin, the EI+ pin must be connected to the VREG pin.

Note that since the PWM oscillator is also used as the clock for internal circuits, a capacitor (about 2000pF) must be connected to the PWM pin even if the PWMIN pin is used for motor control.

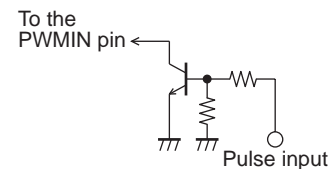

### 5. Hall Input Signals

A signal input with an amplitude in excess of the hysteresis (80mV maximum) is required for the Hall inputs. Considering the possibility of noise and phase displacement, an even larger amplitude is desirable.

If disruptions to the output waveforms (during phase switching) or to the HP output (Hall signal output) occur due to noise, this must be prevented by inserting capacitors across the inputs. The constraint protection circuit uses the Hall inputs to discriminate the motor constraint state. Although the circuit is designed to tolerate a certain amount of noise, care is required when using the constraint protection circuit.

If all three phases of the Hall input signal system go to the same input state, the outputs are all set to the off state (the UL, VL, WL, UH, VH, and WH outputs all go to the low level).

If the outputs from a Hall IC are used, fixing one side of the inputs (either the + or – side) at a voltage within the common-mode input voltage range allows the other input side to be used as an input over the 0V to V<sub>CC</sub> range.

### 6. Under-voltage Protection Circuit

The under-voltage protection circuit turns one side of the outputs (UH, VH, and WH) off when the VREG pin voltage falls below the minimum operation voltage (see the Electrical Characteristics). To prevent this circuit from repeatedly turning the outputs on and off in the vicinity of the protection operating voltage, this circuit is designed with hysteresis. Thus the output will not recover until the operating voltage rises 0.5V (typical).

### 7. Constraint Protection Circuit

When the motor is physically constrained (held stopped), the CSD pin external capacitor is charged (to about 3.0 V) by a constant current of about 2.25μA and is then discharged (to about 1.0V) by a constant current of about 0.15μA.

This process is repeated, generating a saw-tooth waveform. The constraint protection circuit turns motor drive on and off repeatedly based on this saw-tooth waveform. (The UH, VH, and WH side outputs are turned on and off.) Motor drive is on during the period the CSD pin external capacitor is being charged from about 1.0V to about 3.0V, and motor drive is off during the period the CSD pin external capacitor is being discharged from about 3.0V to about 1.0V.

The IC and the motor are protected by this repeated drive on/off operation when the motor is physically constrained.

The motor drive on and off times are determined by the value of the connected capacitor C (in μF).

$$TCSD1 \text{ (drive on period)} \approx 0.89 \times C \text{ (seconds)}$$

$$TCSD2 \text{ (drive off period)} \approx 13.3 \times C \text{ (seconds)}$$

When a 0.47μF capacitor is connected externally to the CSD pin, this iterated operation will have a drive on period of about 0.4 seconds and a drive off period of about 6.3 seconds.

While the motor is turning, the discharge pulse signal (generated once for each Hall input period) that is created by combining the Hall inputs internally in the IC discharges the CSD pin external capacitor. Since the CSD pin voltage does not rise, the constraint protection circuit does not operate.

When the motor is physically constrained, the Hall inputs do not change and the discharge pulses are not generated. As a result, the CSD pin external capacitor is charged by a constant current of 2.5μA to about 3.0V, at which point the constraint protection circuit operates. When the constraint on the motor is released, the constraint protection function is released.

Connect the CSD pin to ground if the constraint protection circuit is not used.

### 8. Forward/Reverse Direction Switching

This IC is designed so that through currents (due to the output transistor off delay time when switching) do not flow in the output when switching directions when the motor is turning. However, if the direction is switched when the motor is turning, current levels in excess of the current limiter value may flow in the output transistors due to the motor coil resistance and the motor back EMF state when switching. Therefore, designers must consider selecting external output transistors that are not destroyed by those current levels or only switching directions after the speed has fallen below a certain speed.

### 9. Handling Different Power Supply Types

When this IC is operated from an externally supplied 5V power supply (4.5 to 5.5V), short the V<sub>CC</sub> pin to the VREG pin and connect them to the external power supply.

When this IC is operated from an externally supplied 12V power supply (8 to 17 V), connect the V<sub>CC</sub> pin to the power supply. (The VREG pin will generate a 5V level to function as the control circuit power supply.)

## 11. Power Supply Stabilization

Since this IC uses a switching drive technique, the power supply line level can be disturbed easily. Therefore capacitors with adequate capacitance to stabilize the power supply line must be inserted between  $V_{CC}$  and ground.

If diodes are inserted in the power supply lines to prevent destruction if the power supply is connected with reverse polarity, the power supply lines are even more easily disrupted, and even larger capacitors are required.

If the power supply is turned on and off by a switch, and if there is a significant distance between that switch and the stabilization capacitor, the supply voltage can be disrupted significantly by the line inductance and surge current into the capacitor. As a result, the withstand voltage of the device may be exceeded. In application such as this, the surge current must be suppressed and the voltage rise prevented by not using ceramic capacitors with a low series impedance, and by using electrolytic capacitors instead.

## 12. VREG Stabilization

To stabilize the VREG voltage, which is the control circuit power supply, a 0.1 $\mu$ F or larger capacitor must be inserted between the VREG pin and ground. The ground side of this capacitor must be connected to the IC ground pin with a line that is as short as possible.

ON Semiconductor and the ON logo are registered trademarks of Semiconductor Components Industries, LLC (SCILLC). SCILLC owns the rights to a number of patents, trademarks, copyrights, trade secrets, and other intellectual property. A listing of SCILLC's product/patent coverage may be accessed at [www.onsemi.com/site/pdf/Patent-Marking.pdf](http://www.onsemi.com/site/pdf/Patent-Marking.pdf). SCILLC reserves the right to make changes without further notice to any products herein. SCILLC makes no warranty, representation or guarantee regarding the suitability of its products for any particular purpose, nor does SCILLC assume any liability arising out of the application or use of any product or circuit, and specifically disclaims any and all liability, including without limitation special, consequential or incidental damages. "Typical" parameters which may be provided in SCILLC data sheets and/or specifications can and do vary in different applications and actual performance may vary over time. All operating parameters, including "Typicals" must be validated for each customer application by customer's technical experts. SCILLC does not convey any license under its patent rights nor the rights of others. SCILLC products are not designed, intended, or authorized for use as components in systems intended for surgical implant into the body, or other applications intended to support or sustain life, or for any other application in which the failure of the SCILLC product could create a situation where personal injury or death may occur. Should Buyer purchase or use SCILLC products for any such unintended or unauthorized application, Buyer shall indemnify and hold SCILLC and its officers, employees, subsidiaries, affiliates, and distributors harmless against all claims, costs, damages, and expenses, and reasonable attorney fees arising out of, directly or indirectly, any claim of personal injury or death associated with such unintended or unauthorized use, even if such claim alleges that SCILLC was negligent regarding the design or manufacture of the part. SCILLC is an Equal Opportunity/Affirmative Action Employer. This literature is subject to all applicable copyright laws and is not for resale in any manner.

## X-ON Electronics

Largest Supplier of Electrical and Electronic Components

*Click to view similar products for [Motor/Motion/Ignition Controllers & Drivers](#) category:*

*Click to view products by [ON Semiconductor](#) manufacturer:*

Other Similar products are found below :

[FSB50550TB2](#) [FSBF15CH60BTH](#) [MSVCPM2-63-12](#) [MSVGW45-14-2](#) [MSVGW54-14-3](#) [MSVGW54-14-5](#) [NTE7043](#) [LA6565VR-TLM-E](#)  
[LB11650-E](#) [LB1837M-TLM-E](#) [LB1845DAZ-XE](#) [LC898300XA-MH](#) [SS30-TE-L-E](#) [26700](#) [LV8281VR-TLM-H](#) [BA5839FP-E2](#) [IRAM236-1067A](#) [LA6584JA-AH](#) [LB11847L-E](#) [NCV70501DW002R2G](#) [AH293-PL-B](#) [STK672-630CN-E](#) [TND315S-TL-2H](#) [FNA23060](#) [FSB50250AB](#)  
[FNA41060](#) [MSVB54](#) [MSVBTC50E](#) [MSVCPM3-54-12](#) [MSVCPM3-63-12](#) [MSVCPM4-63-12](#) [MSVTA120](#) [FSB50550AB](#)  
[NCV70501DW002G](#) [LC898301XA-MH](#) [LV8413GP-TE-L-E](#) [MSVGW45-14-3](#) [MSVGW45-14-4](#) [MSVGW45-14-5](#) [MSVGW54-14-4](#)  
[STK984-091A-E](#) [MP6519GQ-Z](#) [LB11651-E](#) [IRSM515-025DA4](#) [LV8127T-TLM-H](#) [MC33812EKR2](#) [NCP81382MNTXG](#) [TDA21801](#)  
[LB11851FA-BH](#) [NCV70627DQ001R2G](#)