



ON Semiconductor®

<http://onsemi.com>

# LB1205

Monolithic Digital IC

## High-Voltage, Large-Current Darlington Driver

### Overview

The LB1205 is a 4-unit, high withstand voltage (65V), large-current (1.5A) Darlington driver array with input low active configuration and sync output.

### Features

- 4-unit, high withstand voltage design (65V), large-current (1.5A) Darlington driver.
- PNP input type (low active).
- On-chip spark killer diodes.
- On-chip input protection diodes.
- Capable of being driven directly from 5V operated CMOS, TTL.

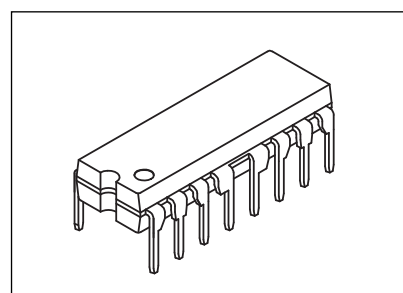

DIP16F(300mil)

### Specifications

**Absolute Maximum Ratings** at  $T_a = 25^\circ\text{C}$

Parameter	Symbol	Conditions	Ratings	Unit
Maximum supply voltage	$V_{DD\text{ max}}$		7.0	V
	$V_{CC\text{ max}}$		62	V
Output supply voltage	$V_O\text{ max}$		65	V
Input supply voltage	$V_{IN\text{ max}}$	$V_{IN} \geq \text{GND}$	$V_{DD}-7.0$ to $V_{DD}-10.0$	V
Output current	$I_O\text{ max}$		1.5	A
Spark killer diode forward current	$I_{FS}$		1.5	A
Allowable power dissipation	$P_d\text{ max}$	Independent IC	1.9	W
		Mounted on the recommended PCB	2.6	W
Operating temperature	$T_{opr}$		-20 to +75	$^\circ\text{C}$
Storage temperature	$T_{stg}$		-55 to +150	$^\circ\text{C}$

Stresses exceeding those listed in the Maximum Ratings table may damage the device. If any of these limits are exceeded, device functionality should not be assumed, damage may occur and reliability may be affected.

**Allowable Operating Conditions** at  $T_a = 25^\circ\text{C}$

Parameter	Symbol	Conditions	Ratings	Unit
Supply voltage range	$V_{DD}$		3.5 to 7.0	V
Input "ON" level voltage	$V_{INon}$	$V_{IN} \geq \text{GND}, I_O = 1.0\text{A}$	$V_{DD}-7.0$ to $V_{DD}-2.6$	V
Input "OFF" level voltage	$V_{INoff}$	$I_O \leq 30\mu\text{A}$	$V_{DD}-0.3$ to $V_{DD}+10.0$	V

Functional operation above the stresses listed in the Recommended Operating Ranges is not implied. Extended exposure to stresses beyond the Recommended Operating Ranges limits may affect device reliability.

### ORDERING INFORMATION

See detailed ordering and shipping information on page 4 of this data sheet.

# LB1205

## Electrical Characteristics at $T_a = 25^\circ\text{C}$ , $V_{DD} = 5\text{V}$

Parameter	Symbol	Conditions	Ratings			Unit
			min	typ	max	
Output saturation voltage	$V_{O\text{sat}1}$	$V_{IN} = V_{DD} - 5.0\text{V}$ , $I_O = 0.5\text{A}$			1.2	V
	$V_{O\text{sat}2}$	$V_{IN} = V_{DD} - 5.0\text{V}$ , $I_O = 1.0\text{A}$			1.5	V
	$V_{O\text{sat}3}$	$V_{IN} = V_{DD} - 5.0\text{V}$ , $I_O = 1.5\text{A}$			2.0	V
Output sustain voltage	$V_{O\text{sus}}$	$I_O = 100\text{mA}$	65			V
Input current	$I_{IN}$	$V_{DD} = 7.0\text{V}$ , $V_{IN} = V_{DD} - 7.0\text{V}$			1.0	mA
Spark killer diode forward voltage	$V_{FS}$	$I_{FS} = 1.5\text{A}$			3.0	V
Spark killer diode reverse current	$I_{RS}$	$V_{CC} = 62\text{V}$ , $V_O = 0\text{V}$			30	$\mu\text{A}$

Product parametric performance is indicated in the Electrical Characteristics for the listed test conditions, unless otherwise noted. Product performance may not be indicated by the Electrical Characteristics if operated under different conditions.

## Package Dimensions

unit : mm

**PDIP16 FUSED LEADS / DIP16F (300 mil)**  
CASE 646AQ  
ISSUE O

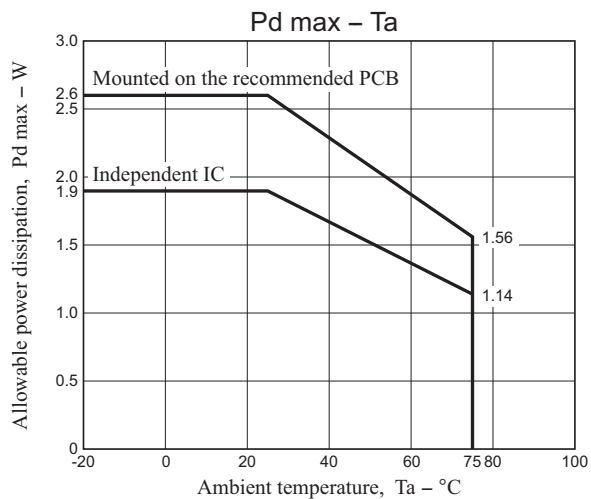
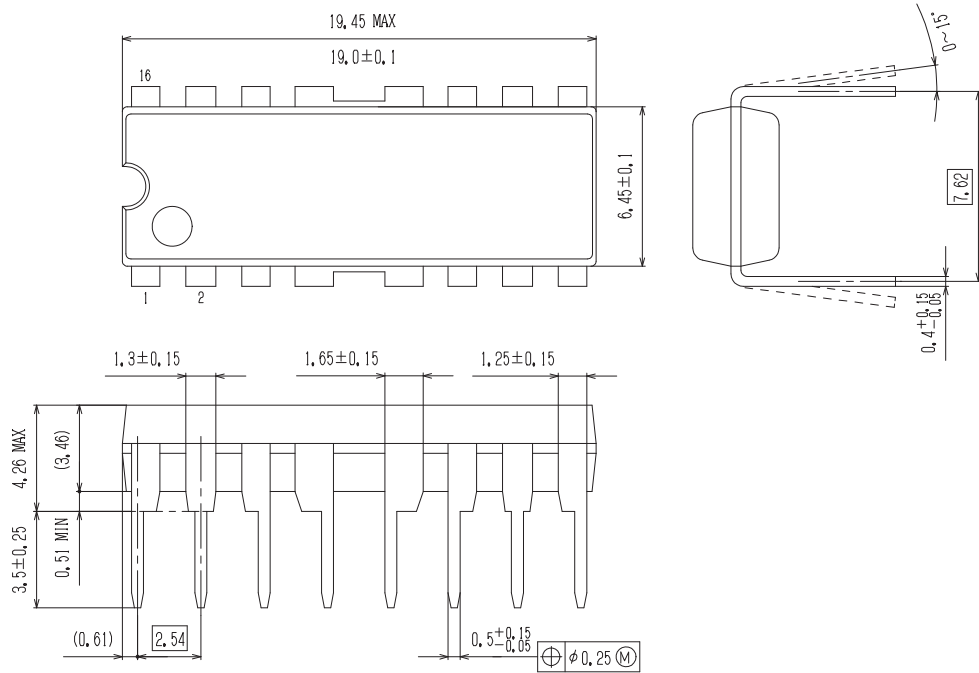

Pin Assignment

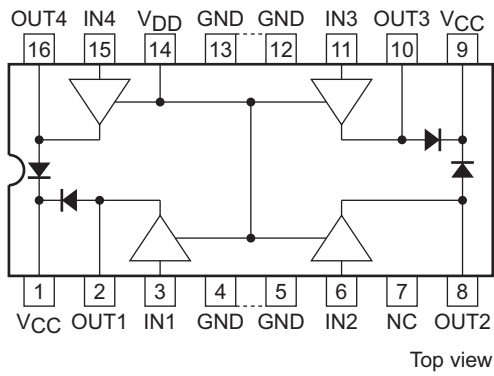

Recommended PCB

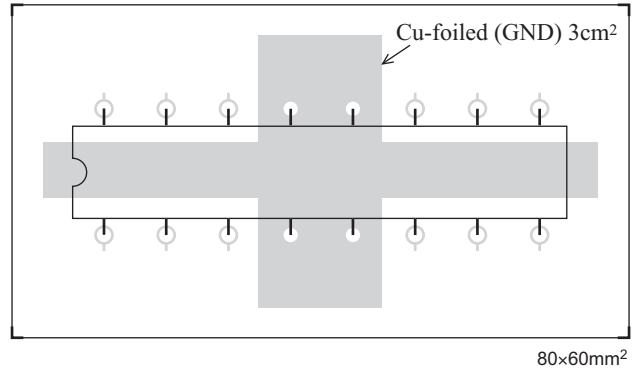

Note: VCC (pins 1 and 9) is shorted internally.

Equivalent Circuit

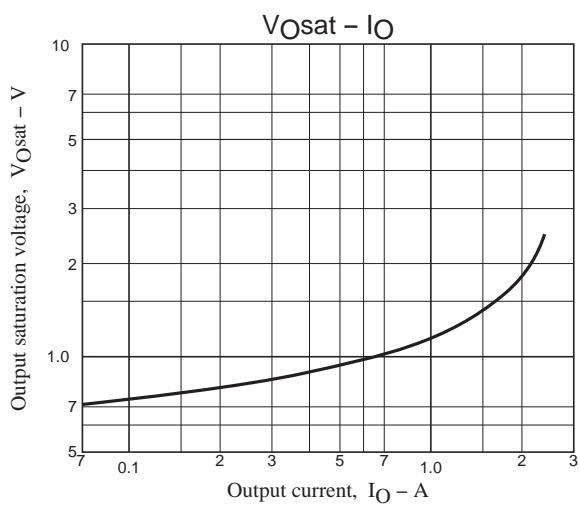
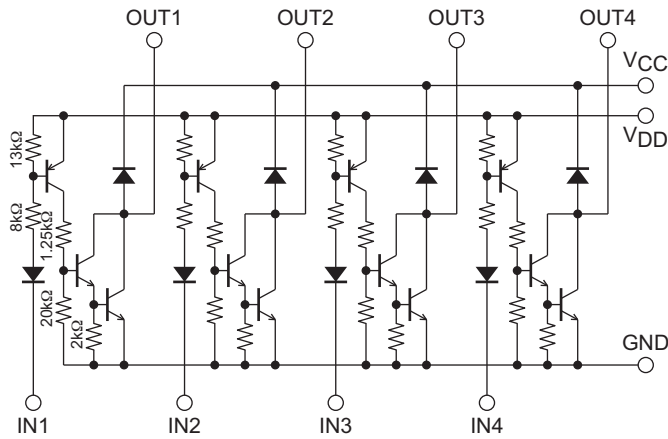

# LB1205

## ORDERING INFORMATION

Device	Package	Shipping (Qty / Packing)
LB1205-E	DIP16F(300mil) (Pb-Free / Halogen Free)	25 / Fan-Fold
LB1205-L-E	DIP16F(300mil) (Pb-Free / Halogen Free)	25 / Fan-Fold
LB1205L-E	DIP16F(300mil) (Pb-Free / Halogen Free)	25 / Fan-Fold
LB1205Z-E	DIP16F(300mil) (Pb-Free / Halogen Free)	25 / Fan-Fold

ON Semiconductor and the ON logo are registered trademarks of Semiconductor Components Industries, LLC (SCILLC). SCILLC owns the rights to a number of patents, trademarks, copyrights, trade secrets, and other intellectual property. A listing of SCILLC's product/patent coverage may be accessed at [www.onsemi.com/site/pdf/Patent-Marking.pdf](http://www.onsemi.com/site/pdf/Patent-Marking.pdf). SCILLC reserves the right to make changes without further notice to any products herein. SCILLC makes no warranty, representation or guarantee regarding the suitability of its products for any particular purpose, nor does SCILLC assume any liability arising out of the application or use of any product or circuit, and specifically disclaims any and all liability, including without limitation special, consequential or incidental damages. "Typical" parameters which may be provided in SCILLC data sheets and/or specifications can and do vary in different applications and actual performance may vary over time. All operating parameters, including "Typicals" must be validated for each customer application by customer's technical experts. SCILLC does not convey any license under its patent rights nor the rights of others. SCILLC products are not designed, intended, or authorized for use as components in systems intended for surgical implant into the body, or other applications intended to support or sustain life, or for any other application in which the failure of the SCILLC product could create a situation where personal injury or death may occur. Should Buyer purchase or use SCILLC products for any such unintended or unauthorized application, Buyer shall indemnify and hold SCILLC and its officers, employees, subsidiaries, affiliates, and distributors harmless against all claims, costs, damages, and expenses, and reasonable attorney fees arising out of, directly or indirectly, any claim of personal injury or death associated with such unintended or unauthorized use, even if such claim alleges that SCILLC was negligent regarding the design or manufacture of the part. SCILLC is an Equal Opportunity/Affirmative Action Employer. This literature is subject to all applicable copyright laws and is not for resale in any manner.

## X-ON Electronics

Largest Supplier of Electrical and Electronic Components

*Click to view similar products for [Darlington Transistors](#) category:*

*Click to view products by [ON Semiconductor](#) manufacturer:*

Other Similar products are found below :

[NJVMJD128T4G](#) [281287X](#) [BDV64B](#) [NJVMJD117T4G](#) [LB1205-L-E](#) [2N6053](#) [MPSA14](#) [TIP140](#) [MPSA13](#) [TIP127L-BP](#) [2N6383](#)  
[ULN2003ACM/TR](#) [2N7371](#) [2N6058](#) [2N6059](#) [2N6051](#) [MJ2501](#) [MJ3001](#) [2SB1560](#) [2SB852KT146B](#) [2SD2560](#) [TIP112TU](#) [BCV27](#)  
[MMBTA13-TP](#) [MMSTA28T146](#) [NTE2557](#) [NJVNJD35N04T4G](#) [MPSA29-D26Z](#) [FJB102TM](#) [BSP61H6327XTSA1](#) [BU941ZPFI](#)  
[2SD1980TL](#) [NTE2350](#) [NTE245](#) [NTE246](#) [NTE2649](#) [NTE46](#) [NTE98](#) [ULN2003ADR2G](#) [NTE2344](#) [NTE2349](#) [NTE2405](#) [NTE243](#) [NTE244](#)  
[NTE247](#) [NTE248](#) [NTE249](#) [NTE253](#) [NTE2548](#) [NTE261](#)