



ON Semiconductor®

<http://onsemi.com>

LB1830MC

Monolithic Digital IC Low-Voltage, Low-Saturation Bidirectional Motor Driver

Overview

The LB1830MC is a low-saturation bidirectional motor driver IC with brake function for use in low-voltage applications.

As both of forward and reverse outputs are regulated, it is especially suited for use in portable equipment.

Features

- Wide operating voltage range: 3.0 to 9.0 V
- Low saturation voltage: 0.2V at $I_O = 40\text{mA}$ (typ)
- Low current drain at standby mode (0.1 μA or less)
- Brake function
- Regulated voltage value (forward/reverse) setting available by one variable resistor
- Regulated output/saturation output switching available
- Built-in spark killer diodes
- Small package: SOIC10

Specifications

Absolute Maximum Ratings at $T_a = 25^\circ\text{C}$

Parameter	Symbol	Conditions	Ratings	Unit
maximum supply voltage	$V_{CC \text{ max}}, V_S \text{ max}$		10.5	V
Output current	$I_M \text{ max}$		500	mA
Input supply voltage	V_{IN}		-0.3 to +10	V
Allowable power dissipation	$P_d \text{ max}$	Mounted on a specified board *	0.82	W
Operating temperature	T_{opr}		-20 to +80	$^\circ\text{C}$
Storage temperature	T_{stg}		-40 to +125	$^\circ\text{C}$

* Specified board: 114.3mm \times 76.1mm \times 1.6mm, glass epoxy board.

Caution 1) Absolute maximum ratings represent the value which cannot be exceeded for any length of time.

Caution 2) Even when the device is used within the range of absolute maximum ratings, as a result of continuous usage under high temperature, high current, high voltage, or drastic temperature change, the reliability of the IC may be degraded. Please contact us for the further details.

Stresses exceeding Maximum Ratings may damage the device. Maximum Ratings are stress ratings only. Functional operation above the Recommended Operating Conditions is not implied. Extended exposure to stresses above the Recommended Operating Conditions may affect device reliability.

LB1830MC

Allowable Operating Ranges at $T_a = 25^\circ\text{C}$

Parameter	Symbol	Conditions	Ratings	Unit
Supply voltage	V_{CC}, V_S		3.0 to 9.0	V
Input high level voltage	V_{IH}		2.0 to 9.0	V
Input low level voltage	V_{IL}		-0.3 to +0.3	V
Control voltage	V_C		1.0 to 6.0	V

Electrical Characteristics at $T_a = 25^\circ\text{C}, V_{CC} = 6\text{V}$

Parameter	Symbol	Conditions	Ratings			Unit
			min	typ	max	
Current drain	I_{CC0}	$I_{N1} = I_{N2} = V_m = 0\text{V}, V_C = V_{ref}$ at standby mode		0.1	10	μA
	I_{CC1}	Forward/reverse, control, load OPEN		2	3	mA
	I_{CC2}	Forward/reverse, saturation, load OPEN		3	5	mA
	I_{CC3}	Braking, load OPEN		5	8	mA
Output saturation voltage	V_{sat1}	$I_O = 40\text{mA}$ (upper side + lower side)		0.2	0.3	V
	V_{sat2}	$I_O = 80\text{mA}$ (upper side + lower side)		0.4	0.6	V
Reference voltage	V_{ref}	$I_{V_{ref}} = 1\text{mA}$	1.85	2.0	2.15	V
Voltage characteristics of output voltage	$\Delta V_{O\text{-Line}}$	$V_O = 5\text{V}, V_{CC} = 5.5$ to $9\text{V}, I_O = 40\text{mA}$			80	mA
Current characteristics of output voltage	$\Delta V_{O\text{-Load}}$	$V_O = 5\text{V}, V_{CC} = 6\text{V}, I_O = 10$ to 80mA			50	mA
Input current	I_{IN}	$V_{IN} = 5\text{V}$		90	150	μA
Output voltage	V_O	$V_C = 2\text{V}$	$2.3 \times V_C$		$2.5 \times V_C$	V

Package Dimensions

unit : mm (typ)

3426A

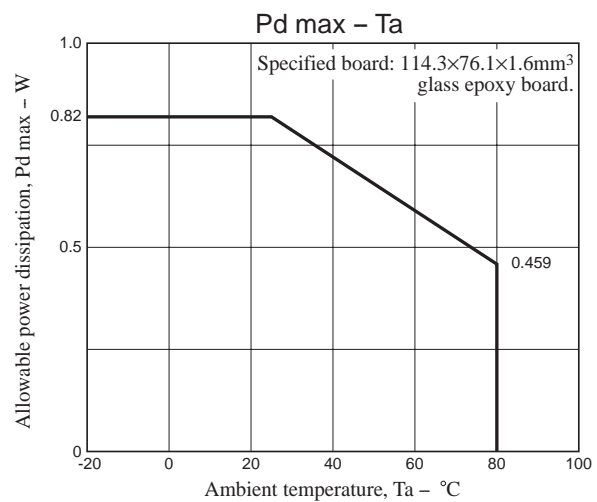
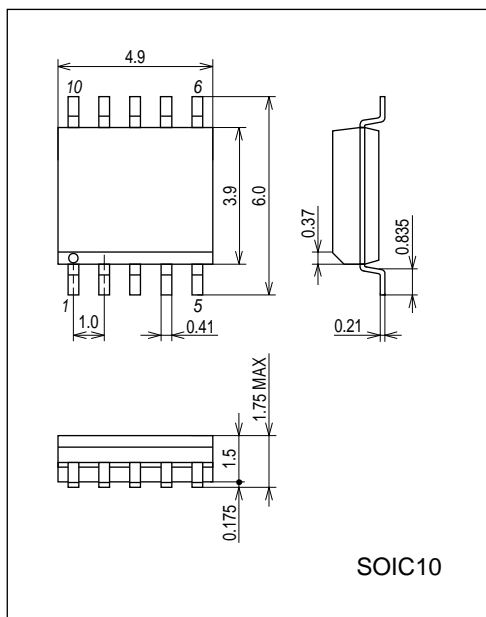

LB1830MC

Pin Assignment

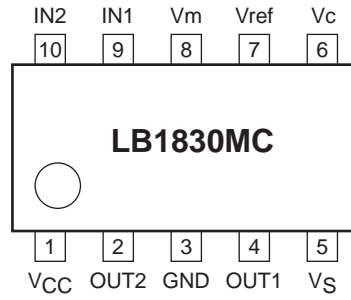

Block Diagram

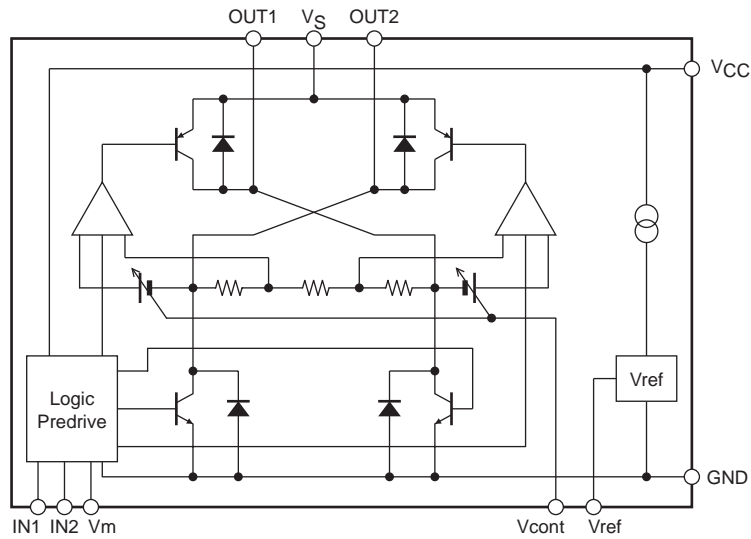

- The output voltage (voltage between output pins) V_O during drive with constant voltage is set as follows:

$$V_O = (V_C \text{ pin input voltage}) \times 2.4 \text{ (typical)}$$
- There is no hierarchical relationship among voltages; V_{CC} (control supply voltage), V_S (motor supply voltage), $IN1/IN2$ (input signal voltage).

Truth Table

Input			Output		Mode
IN1	IN2	Vm	OUT1	OUT2	
L	L	L	OFF	OFF	Standby
H	L	L	H	L	Forward (Regulated)
H	L	H	H	L	Forward (Saturation)
L	H	L	L	H	Reverse (Regulated)
L	H	H	L	H	Reverse (Saturation)
H	H	*	L	L	Brake

* when in saturation mode, $V_C = V_S$ available.

LB1830MC

Application Circuit Example

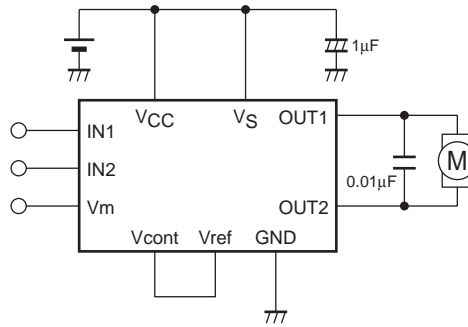

ON Semiconductor and the ON logo are registered trademarks of Semiconductor Components Industries, LLC (SCILLC). SCILLC owns the rights to a number of patents, trademarks, copyrights, trade secrets, and other intellectual property. A listing of SCILLC's product/patent coverage may be accessed at www.onsemi.com/site/pdf/Patent-Marking.pdf. SCILLC reserves the right to make changes without further notice to any products herein. SCILLC makes no warranty, representation or guarantee regarding the suitability of its products for any particular purpose, nor does SCILLC assume any liability arising out of the application or use of any product or circuit, and specifically disclaims any and all liability, including without limitation special, consequential or incidental damages. "Typical" parameters which may be provided in SCILLC data sheets and/or specifications can and do vary in different applications and actual performance may vary over time. All operating parameters, including "Typicals" must be validated for each customer application by customer's technical experts. SCILLC does not convey any license under its patent rights nor the rights of others. SCILLC products are not designed, intended, or authorized for use as components in systems intended for surgical implant into the body, or other applications intended to support or sustain life, or for any other application in which the failure of the SCILLC product could create a situation where personal injury or death may occur. Should Buyer purchase or use SCILLC products for any such unintended or unauthorized application, Buyer shall indemnify and hold SCILLC and its officers, employees, subsidiaries, affiliates, and distributors harmless against all claims, costs, damages, and expenses, and reasonable attorney fees arising out of, directly or indirectly, any claim of personal injury or death associated with such unintended or unauthorized use, even if such claim alleges that SCILLC was negligent regarding the design or manufacture of the part. SCILLC is an Equal Opportunity/Affirmative Action Employer. This literature is subject to all applicable copyright laws and is not for resale in any manner.

X-ON Electronics

Largest Supplier of Electrical and Electronic Components

Click to view similar products for [Motor/Motion/Ignition Controllers & Drivers](#) category:

Click to view products by [ON Semiconductor](#) manufacturer:

Other Similar products are found below :

[FSB50550TB2](#) [FSBF15CH60BTH](#) [MSVCPM2-63-12](#) [MSVGW45-14-2](#) [MSVGW54-14-3](#) [MSVGW54-14-5](#) [NTE7043](#) [LA6565VR-TLM-E](#)
[LB11650-E](#) [LB1837M-TLM-E](#) [LB1845DAZ-XE](#) [LC898300XA-MH](#) [SS30-TE-L-E](#) [26700](#) [LV8281VR-TLM-H](#) [BA5839FP-E2](#) [IRAM236-1067A](#) [LA6584JA-AH](#) [LB11847L-E](#) [NCV70501DW002R2G](#) [AH293-PL-B](#) [STK672-630CN-E](#) [TND315S-TL-2H](#) [FNA23060](#) [FSB50250AB](#)
[FNA41060](#) [MSVB54](#) [MSVBTC50E](#) [MSVCPM3-54-12](#) [MSVCPM3-63-12](#) [MSVCPM4-63-12](#) [MSVTA120](#) [FSB50550AB](#)
[NCV70501DW002G](#) [LC898301XA-MH](#) [LV8413GP-TE-L-E](#) [MSVGW45-14-3](#) [MSVGW45-14-4](#) [MSVGW45-14-5](#) [MSVGW54-14-4](#)
[STK984-091A-E](#) [MP6519GQ-Z](#) [LB11651-E](#) [IRSM515-025DA4](#) [LV8127T-TLM-H](#) [MC33812EKR2](#) [NCP81382MNTXG](#) [TDA21801](#)
[LB11851FA-BH](#) [NCV70627DQ001R2G](#)