

# LB8503V

## DC Fan Motor Speed Control IC

### Overview

The LB8503V is an improved functionality version of the LB8500 and LB8502 products that features the added functions listed below. The LB8503V supports both single-phase and three-phase applications.

### Added Functions

- Supports Origin Shifting in the Speed Control Function
- Adds a Dedicated Pin for Setting the Soft Start Time:  
This allows a longer start time to be set without reducing the response time when changing speed.
- FG Output Pin Added

### Functions and Features

- Achieves Linear Speed Control:  
Applications can set the slope of the change in motor speed with change in the input duty.
- Minimized Speed Fluctuations in the Presence of Line or Load Variations
- Allows a Minimum Speed to be Set
- Soft Start Function
- Settings Using External Capacitors and Resistors  
(to Support Easier Mass Production of End Products)
- Supports both PWM Duty and Analog Voltage Control Inputs



ON Semiconductor®

[www.onsemi.com](http://www.onsemi.com)

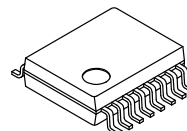

SSOP16  
CASE 565AM

### MARKING DIAGRAM

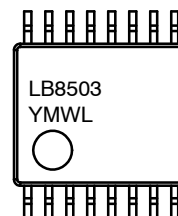

LB8503 = Specific Device Code  
Y = Year of Production  
M = Assembly Operation Month  
WL = Wafer Lot Number

### ORDERING INFORMATION

Device	Package	Shipping†
LB8503V-TLM-E	SSOP16 (Pb-Free)	2,000 / Tape & Reel
LB8503V-W-AH	SSOP16 (Pb-Free/ Halogen Free)	2,000 / Tape & Reel

†For information on tape and reel specifications, including part orientation and tape sizes, please refer to our Tape and Reel Packaging Specification Brochure, BRD8011/D.

# LB8503V

## SPECIFICATIONS

### ABSOLUTE MAXIMUM RATINGS (T<sub>A</sub> = 25°C)

Parameter	Symbol	Conditions	Ratings	Unit
Supply Voltage	V <sub>CC</sub> max	V <sub>CC</sub> pin	18	V
Output Current	I <sub>O</sub> max	E0 pin	3	mA
FG Output Pin Output Voltage	V <sub>FG</sub> max	FG <sub>OUT</sub> pin	18	V
FG Output Pin Output Current	I <sub>FG</sub> max	FG <sub>OUT</sub> pin	10	mA
Allowable Power Dissipation	P <sub>d</sub> max	When mounted on a circuit board (Note 1)	0.8	W
Operating Temperature	T <sub>opr</sub>		-30 to +95	°C
Storage Temperature	T <sub>stg</sub>		-55 to +150	°C

Stresses exceeding those listed in the Maximum Ratings table may damage the device. If any of these limits are exceeded, device functionality should not be assumed, damage may occur and reliability may be affected.

1. Specified circuit board: 114.3 × 76.1 × 1.6mm<sup>3</sup>, glass epoxy.

### RECOMMENDED OPERATING RANGE (T<sub>A</sub> = 25°C)

Parameter	Symbol	Conditions	Ratings	Unit
Supply Voltage Range 1	V <sub>CC1</sub>	V <sub>CC</sub> pin	7.5 to 17	V
Supply Voltage Range 2	V <sub>CC2</sub>	V <sub>CC</sub> pin, with V <sub>CC</sub> shorted to 6 VREG	5.5 to 6.5	V
Output Current	I <sub>O</sub>	E0 pin	2.5	mA
6 V Constant Voltage Output Current	I <sub>REG</sub>		-5	mA
CTL Pin Voltage	V <sub>CTL</sub>		0 to 6 VREG	V
LIM Pin Voltage	V <sub>LIM</sub>		0 to 6 VREG	V
VC1 Pin Voltage	V <sub>Cl</sub>		0 to 6 VREG	V

Functional operation above the stresses listed in the Recommended Operating Ranges is not implied. Extended exposure to stresses beyond the Recommended Operating Ranges limits may affect device reliability.

### ELECTRICAL CHARACTERISTICS (T<sub>A</sub> = 25°C, V<sub>CC</sub> = 12 V)

Parameter	Symbol	Conditions	Min	Typ	Max	Unit
Supply Current	I <sub>CC</sub>			5.5	6.5	mA

### 6 V CONSTANT VOLTAGE OUTPUT (VREG PIN)

Output Voltage	VREG	LB8503-TLM-E LB8503-W-AH	5.8 5.9	6.0 6.0	6.2 6.1	V
Line Regulation	ΔVREG1	V <sub>CC</sub> = 8 to 17 V		40	100	mV
Load Regulation	ΔVREG2	I <sub>O</sub> = -5 to 5 mA		10	100	mV
Temperature Coefficient	ΔVREG3	Design target (Note 2)		0		mV/°C

### INTEGRATING AMPLIFIER BLOCK (E01)

Common-mode Input Voltage Range	V <sub>ICM</sub>		2.0		VREG	V
High-level Output Voltage	V <sub>OH</sub> (E01)	IEO1 = -0.2 mA	VREG - 1.2	VREG - 0.8		V
Low-level Output Voltage	V <sub>OL</sub> (E01)	IEO1 = 0.2 mA		0.8	1.0	V

### INTEGRATING AMPLIFIER BLOCK (E03)

High-level Output Voltage	V <sub>OH</sub> (E03)	IEO1 = -0.2 mA	VREG - 1.2	VREG - 0.8		V
Low-level Output Voltage	V <sub>OL</sub> (E03)	IEO1 = 0.2 mA		0.8	1.0	V

# LB8503V

## ELECTRICAL CHARACTERISTICS ( $T_A = 25^\circ\text{C}$ , $V_{CC} = 12\text{ V}$ ) (continued)

Parameter	Symbol	Conditions	Min	Typ	Max	Unit
-----------	--------	------------	-----	-----	-----	------

### FGIN PIN

High-level Input Voltage	VFGH		3.0		VREG	V
Low-level Input Voltage	VFGL		0		1.5	V
Input Open Voltage	VFGO		VREG - 0.5		VREG	V
Hysteresis	VFGS		0.2	0.3	0.4	V
High-level Input Current	IFGH	VFGIN = 6 VREG	-10	0	10	$\mu\text{A}$
Low-level Input Current	IFGL	VFGIN = 0 V	-140	-110		$\mu\text{A}$

### FGOUT PIN

Output Low Saturation Voltage	VFG			0.2	0.3	V
Output Leakage Current	IFGL				10	$\mu\text{A}$

### RC PIN

High-level Output Voltage	$V_{OH}(\text{RC})$		3.2	3.45	3.7	V
Low-level Output Voltage	$V_{OL}(\text{RC})$		0.8	0.95	1.05	V
Clamp Voltage	$V_{CLP}(\text{RC})$		1.5	1.65	1.8	V

### CTL PIN

High-level Input Voltage	VCTH		2.0		VREG	V
Low-level Input Voltage	VCTL		0		1.0	V
Input Open Voltage	VCTO		VREG - 0.5		VREG	V
High-level Input Current	ICTH	VFGIN = 6 VREG	-10	0	10	$\mu\text{A}$
Low-level Input Current	ICTL	VFGIN = 0 V	-140	-110		$\mu\text{A}$

### C PIN

High-level Input Voltage	$V_{OH}(\text{C})$		VREG - 0.3	VREG - 0.1		V
Low-level Input Voltage	$V_{OL}(\text{C})$		1.8	2.0	2.2	V

### LIM PIN

Input Bias Current	IB(LIM)		-1		1	$\mu\text{A}$
Common-mode Input Voltage Range	VILIM		2.0		VREG	V

### SOFT PIN

Charge Current	IC(SOFT)			1.4		$\mu\text{A}$
Operation Voltage Range	VISOFT		2.0		VREG	V

### VCI PIN

Input Bias Current	IB(VCI)		-1		1	$\mu\text{A}$
Common-mode Input Voltage Range	VIVCI		2.0		VREG	V

### VCO PIN

High-level Output Voltage	$V_{OH}(\text{VCO})$			VREG - 0.2		V
Low-level Output Voltage	$V_{OL}(\text{VCO})$			2.0		V

Product parametric performance is indicated in the Electrical Characteristics for the listed test conditions, unless otherwise noted. Product performance may not be indicated by the Electrical Characteristics if operated under different conditions.

2. The design specification items are design guarantees and are not measured.

## LB8503V

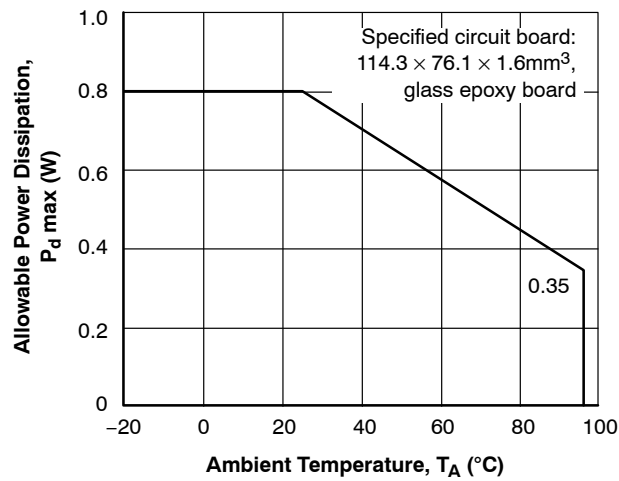

Figure 1.  $P_d$  max vs.  $T_A$

### PIN ASSIGNMENT

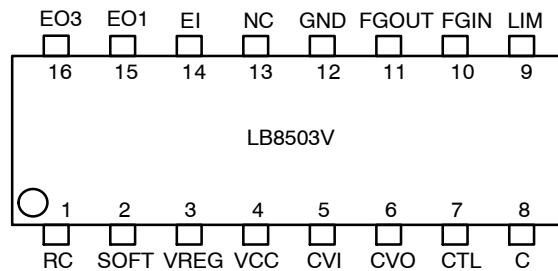

Figure 2. Pin Assignment (Top View)

### PIN FUNCTION DESCRIPTION

Pin Name	Pin No.	Description
RC	1	One-shot multivibrator pulse width setting. Connect a resistor between this pin and VREG, and a capacitor between this pin and ground.
SOFT	2	Soft start time setting. Connect a capacitor between this pin and VREG.
VREG	3	6 V regulator output. Connect a capacitor between this pin and ground for stabilization.
VCC	4	Power supply. Connect a capacitor between this pin and ground for stabilization.
CVI	5	Control voltage input
CVO	6	Duty pulse signal smoothed voltage output
CTL	7	Duty pulse signal input. The speed is controlled by the duty of this pulse signal.
C	8	Duty pulse signal smoothing. Connect a capacitor between this pin and VREG.
LIM	9	Minimum speed setting. Normally, the 6V regulator level is resistor divided to set this pin's input level.
FGIN	10	FG pulse input
FGOUT	11	FG pulse output
GND	12	Grand pin
NC	13	NC pin
EI	14	One-shot multivibrator output and integrating amplifier input. A capacitor must be connected between this pin and EO for this integration.
EO1	15	Integrating amplifier output. (For use with an accelerating driver IC if the command voltage becomes low (single-phase systems).)
EO3	16	Integrating amplifier inverting output. (For use with an accelerating driver IC if the command voltage becomes high (three-phase systems).)

# LB8503V

## BLOCK DIAGRAMS AND APPLICATION EXAMPLES

Combination with an accelerating driver IC when the command voltage goes low (single-phase systems).

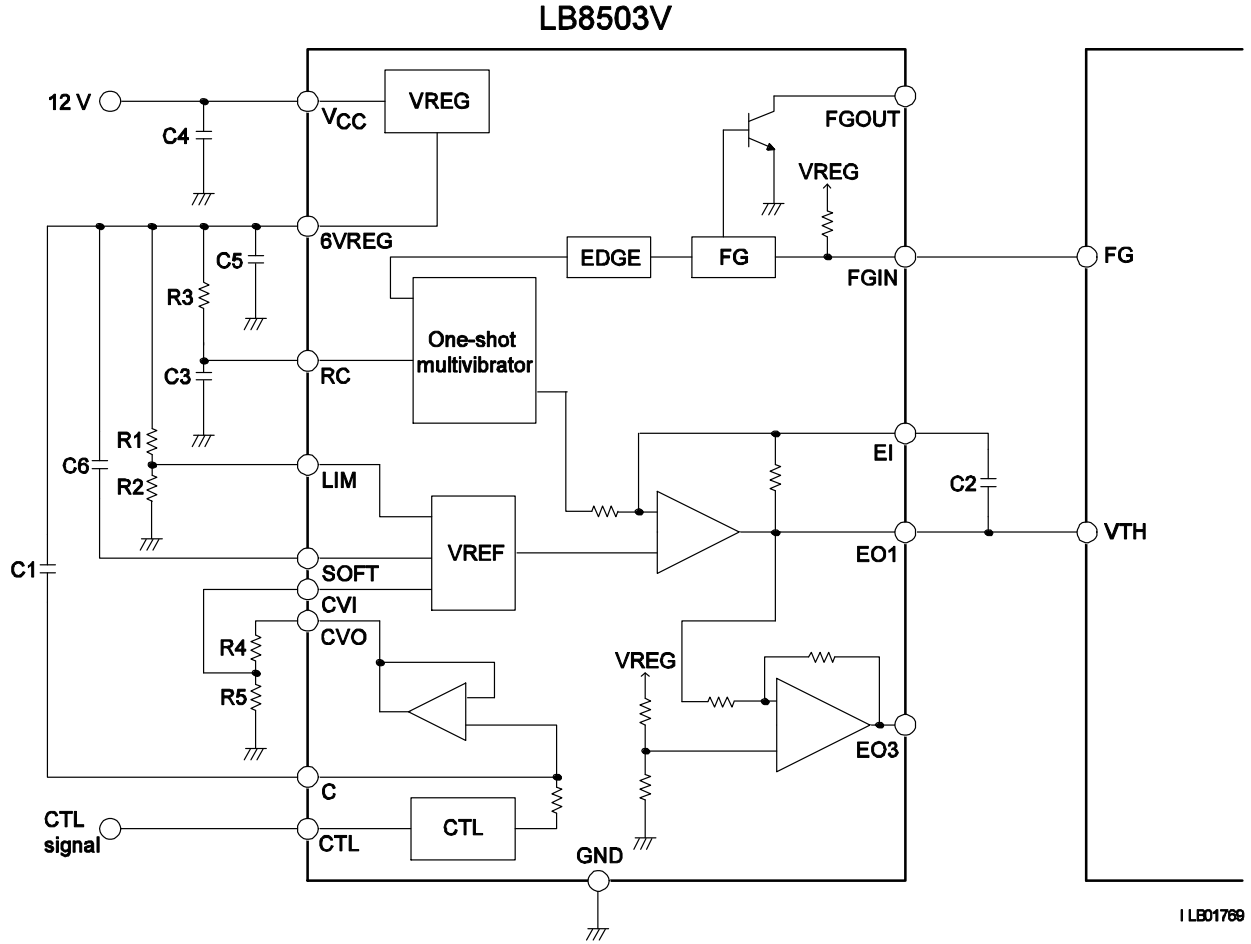

Figure 3.

# LB8503V

Combination with an accelerating driver IC when the command voltage goes high (three-phase systems).

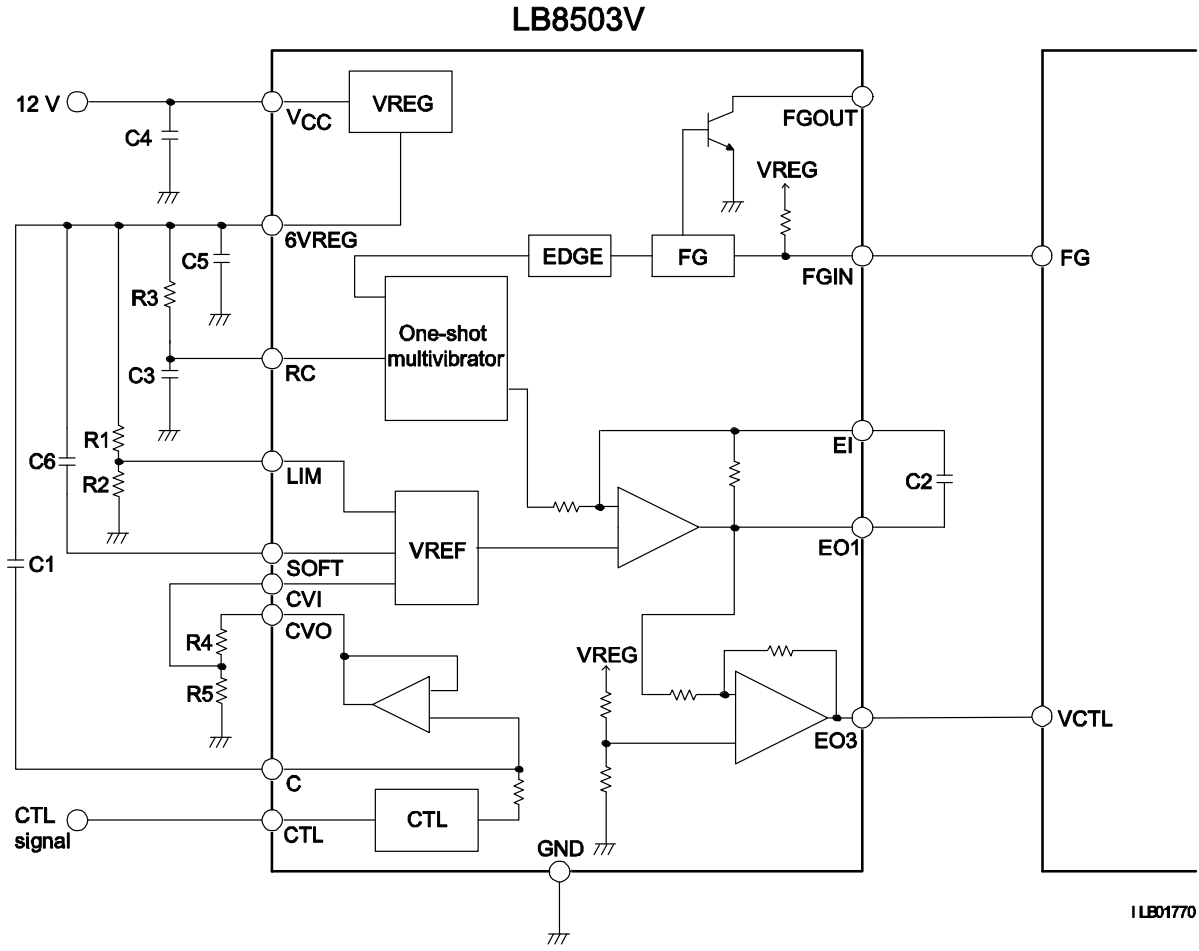

Figure 4.

1LB01770

# LB8503V

## Speed Control Diagrams

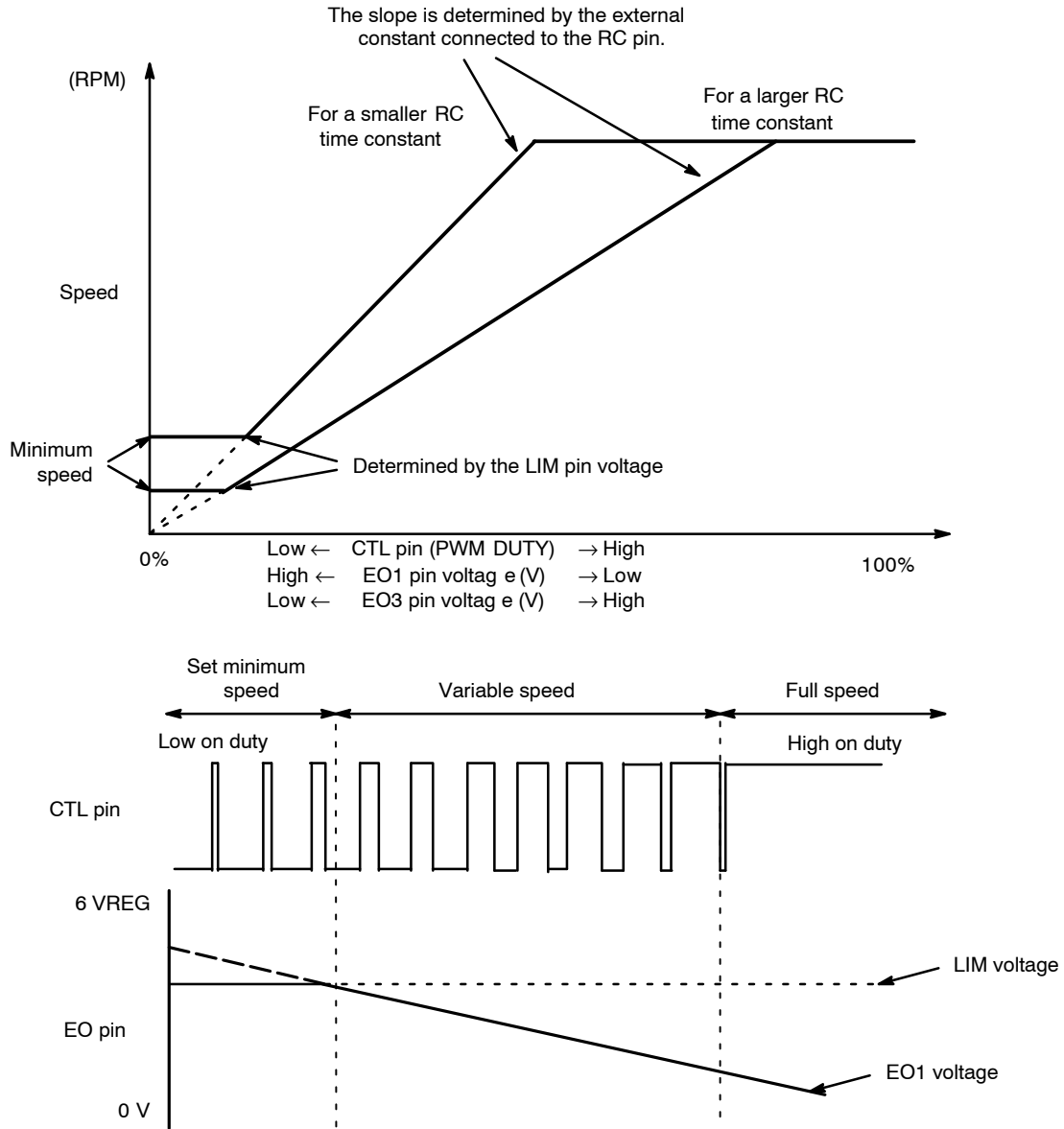

Figure 5.

## Startup Timing (Soft Start)

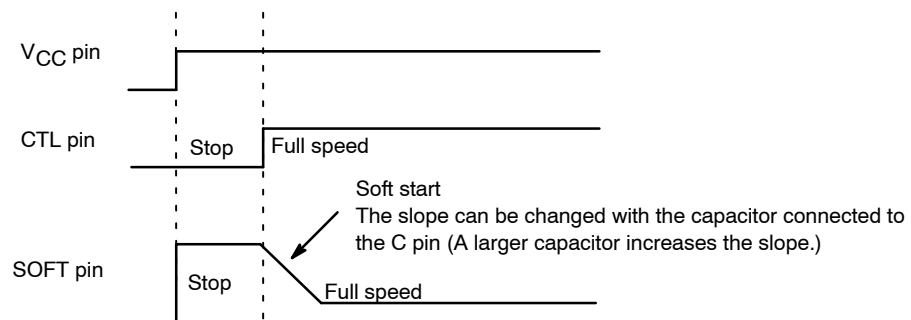

Figure 6.

# LB8503V

## Supplementary Operational Descriptions

The LB8503V accepts a duty pulse input and an FG signal from the driver IC, and generates the driver IC control

voltage so that the FG period (motor speed) becomes proportional to the control voltage.

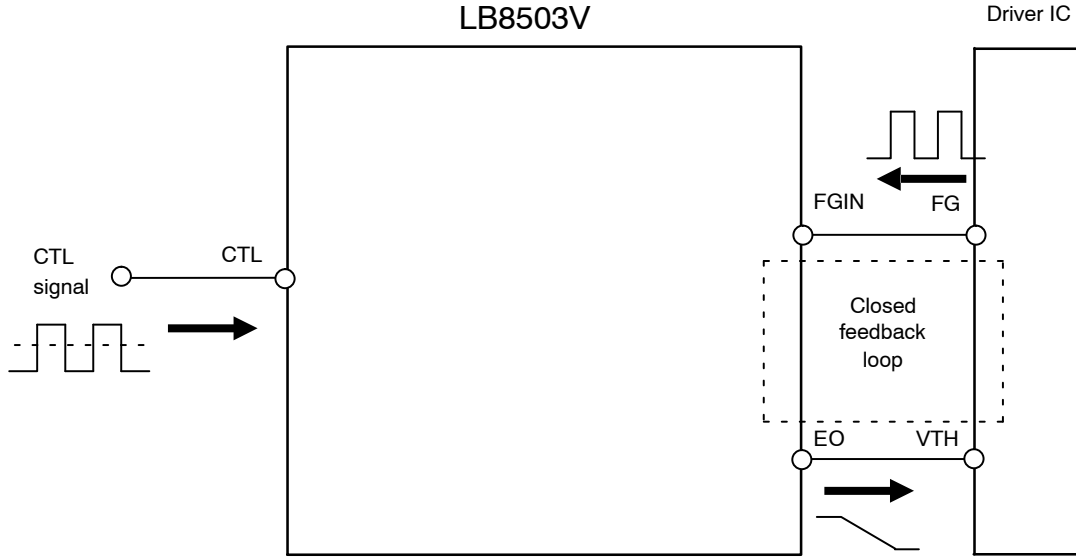

Figure 7.

As shown in the figure below, the LB8503V generates a pulse signal from edges on the FG signal and then generates a pulse width waveform determined by the RC time constant in a one-shot multivibrator.

The LB8503V then integrates that pulse waveform to create the output driver IC control voltage (a DC voltage).

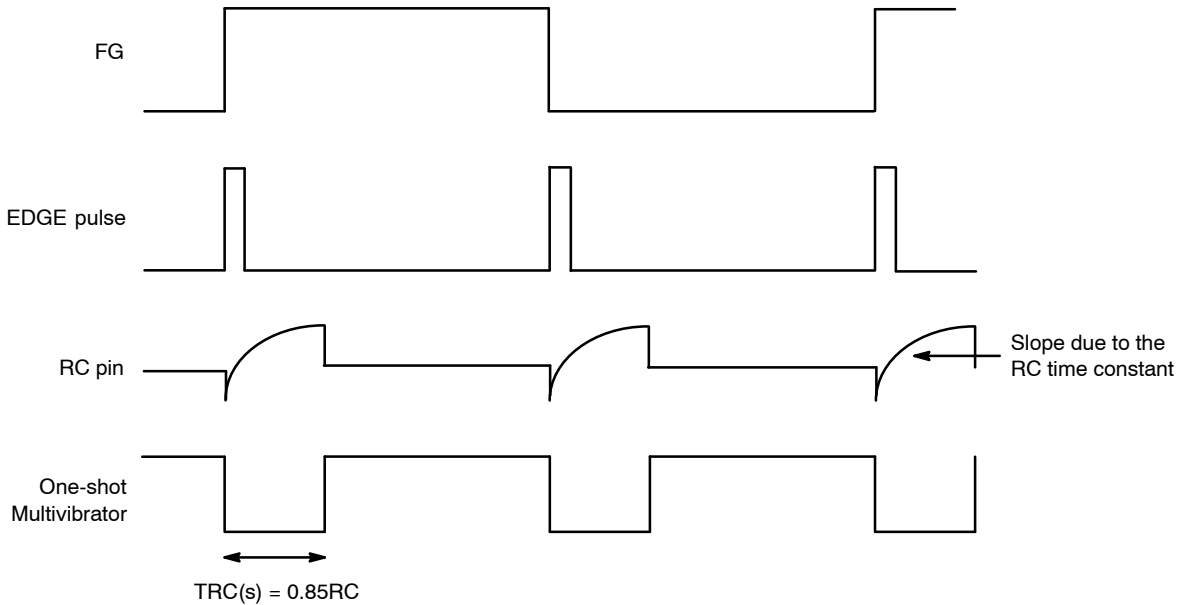

Figure 8.

It is also possible to change the slope of the VCTL/speed relationship as shown in the speed control diagram in the previous section by changing the pulse width with the RC time constant.

Note, however, that since pulses determined by this RC time constant are used, variation in the RC components will appear as speed control errors.



**Pin Setting Procedures  
(Provided for Reference Purposes)**

**[RC Pin]**

The slope in the speed control diagram is determined by the RC pin time constant.

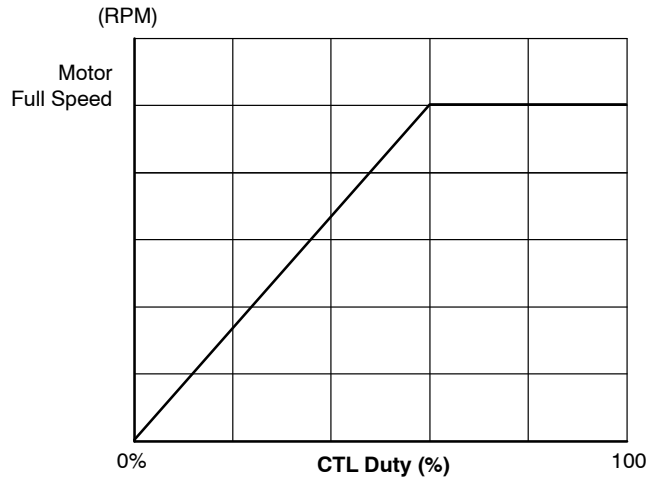

**Figure 9.**

1. Determine the FG signal frequency ( $f_{FG}$  (Hz)) at the motor's highest speed.  
(When 2 FG pulses are created on each motor revolution.)

$$f_{FG}(\text{Hz}) = \frac{2 \text{ rpm}}{60} \quad (\text{eq. 1})$$

2. Determine the time constant for the RC pin.  
(Let DUTY be the control duty at the highest motor speed. For example, 100% = 1.0, 60% = 0.6)

$$R \times C = \frac{\text{DUTY}}{3 \times 0.85 \times f_{FG}} \quad (\text{eq. 2})$$

3. Determine the resistor and capacitor values.  
The range of capacitors that can be used is from 0.01 to 0.015  $\mu\text{F}$  due to the charge capabilities of

the RC pin circuit.

Therefore, an appropriate resistor value can be determined from either (eq. 3) or (eq. 4) below from the result obtained in step above.

$$R = \frac{R \times C}{0.01 \mu\text{F}} \quad (\text{eq. 3})$$

$$R = \frac{R \times C}{0.015 \mu\text{F}} \quad (\text{eq. 4})$$

Note that the temperature characteristics of the curve are determined by the temperature characteristics of the capacitor connected to the RC pin.

A capacitor with excellent temperature characteristics must be used to minimize motor speed variation with temperature.

**[CVO and CVI Pins]**

These pins determine the origin of the slope. (To set the origin to 0% at 0 rpm, short CVO to CVI.)

1. X axis shift (Resistor dividing the CVO to ground potential).

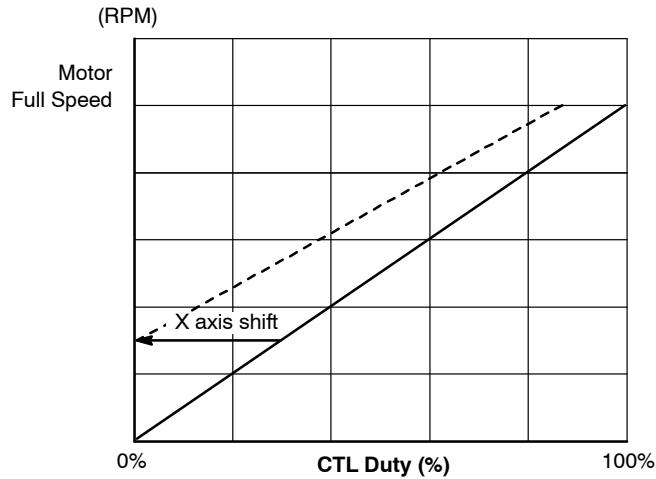

Figure 10.

To shift the characteristics from a 0% = 0 rpm origin to a situation where the speed at a duty of 30% is shifted to 0%:

First, determine the required CVI pin input voltage at 0%.

$$\begin{aligned} CVI &= 6 - (4 \times DUTY) = 6 - (4 \times 0.3) \\ &= 6 - 1.2 = 4.8 \text{ V} \end{aligned} \quad (\text{eq. 5})$$

Next, when CVO is 6 V, determine the resistor values for the resistor divider between CVO and ground such that the midpoint becomes 4.8 V.

$$\frac{CVO - CVI}{CVI - \text{ground}} = \frac{1.2 \text{ V}}{4.8 \text{ V}} = \text{a ratio of 1:4} \quad (\text{eq. 6})$$

From the above, the desired resistor values will be 20 kΩ between CVO and CVI and 80 kΩ between CVI and ground.

Note that the slope will change. (In this case, since the resistor ratio is 1:4, the result will be 4/5 of (or 0.8 times) the original slope.)

If required, the RC pin resistor value must be changed to correct the slope.

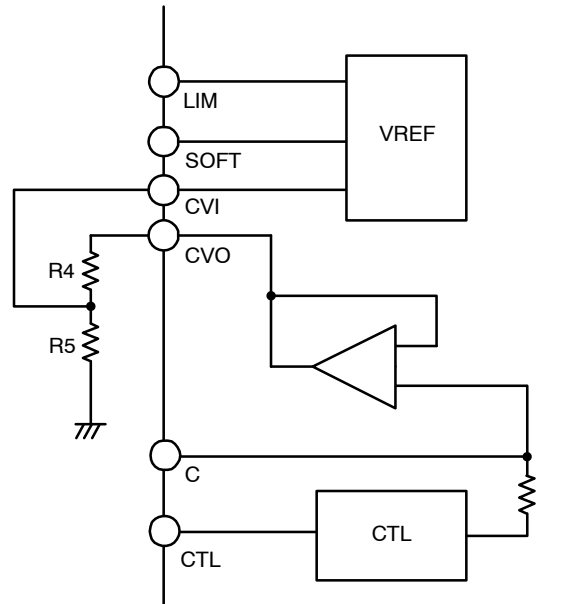

Figure 11.

2. Y axis shift  
 (Resistor dividing the CVO to V<sub>CC</sub> potential)

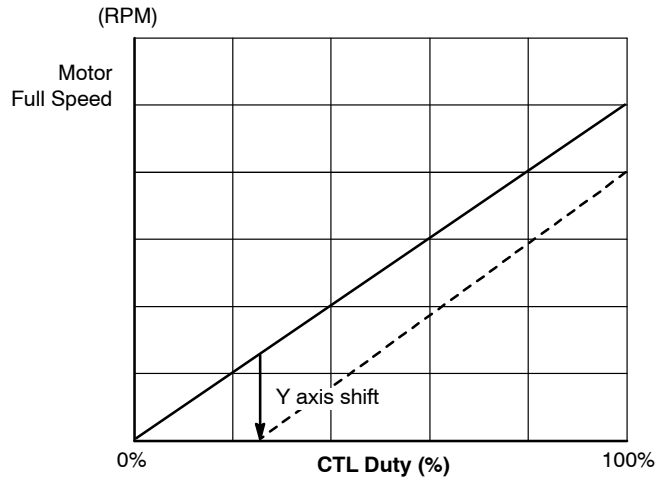

Figure 12.

To shift the characteristics from a 0% = 0 rpm origin to a situation where the speed is 0 rpm at a duty of 30%:  
 First, determine the required CVO pin input voltage at 0%.

$$\begin{aligned} \text{CVO} &= 6 - (4 \times \text{DUTY}) = 6 - (4 \times 0.25) \\ &= 6 - 1 = 5 \text{ V} \end{aligned} \quad (\text{eq. 7})$$

Determine the resistor values such that at CVO = 5 V, CVI becomes 6 V.

$$\frac{\text{CVO} - \text{CVI}}{\text{CVI} - V_{\text{CC}}} = \frac{1 \text{ V}}{6 \text{ V}} = \text{a ratio of } 1:6 \quad (\text{eq. 8})$$

From the above, the desired resistor values will be 20 kΩ between CVO and CVI and 80 kΩ between CVI and ground.

(Due to the current capability of the CVO pin, the total resistor value must exceed 100 kΩ.)

Note that the slope will change. (In this case, since the resistor ratio is 1:6, the result will be 6/7 of (or 0.86 times) the original slope.)

If required, the RC pin resistor value must be changed to correct the slope.

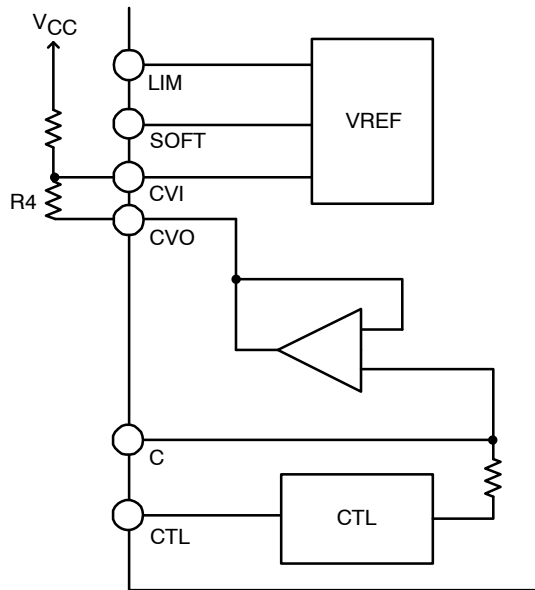

Figure 13.

**[LIM Pin]**

The minimum speed is determined by the LIM pin voltage.

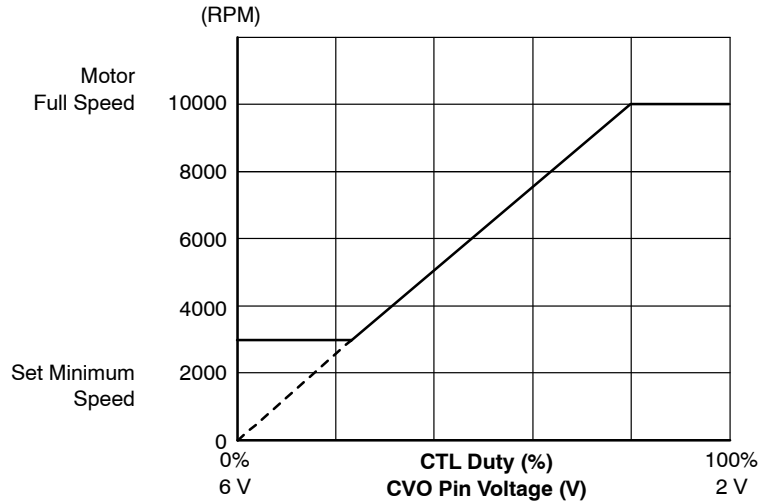

Figure 14.

1. Determine the ratio of the required minimum speed and the maximum speed.

$$R_a = \frac{\text{minimum speed}}{\text{maximum speed}} \quad (\text{eq. 9})$$

In the example in the figure above:

$$R_a = \frac{\text{minimum speed}}{\text{maximum speed}} = \frac{3000}{10000} = 0.3 \quad (\text{eq. 10})$$

2. Determine the product of the duty that produces the maximum speed and the value from Equation 9.

$$C_a = \text{maximum speed duty} \times R_a \quad (\text{eq. 11})$$

For example:

$$C_a = \text{maximum speed duty} \times R_a = 0.9 \times 0.3 = 0.24 \quad (\text{eq. 12})$$

3. Determine the required LIM pin voltage:

$$\text{LIM} = 6 - (4 \times C_a) \quad (\text{eq. 13})$$

For example:

$$\begin{aligned} \text{LIM} &= 6 - (4 \times C_a) \\ &= 6 - (4 \times 0.24) \approx 5 \text{ V} \end{aligned} \quad (\text{eq. 14})$$

4. Generate the LIM voltage by resistor dividing the 6 V regulator voltage.

For example, the resistor ratio to create a 5 V level will be 1:5.

Thus the resistor values will be 10 kΩ between 6 VREG and LIM and 51 kΩ between LIM and ground.

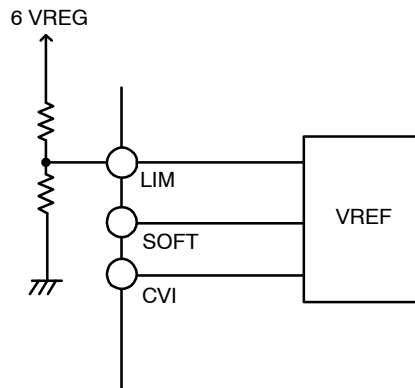

Figure 15.

## LB8503V

### [C Pin]

Since a capacitor that can smooth the pin voltage is connected to the C pin, if the CTL pin input signal frequency is  $f$  (Hz), then the capacitor must meet the following condition. (Here,  $R$  is the IC internal resistance of  $180\ \Omega$  (typical).)

$$\frac{1}{f} = t < RC \quad (\text{eq. 15})$$

Note that the larger the capacitor, the slower its response to changes in the input signal will be.

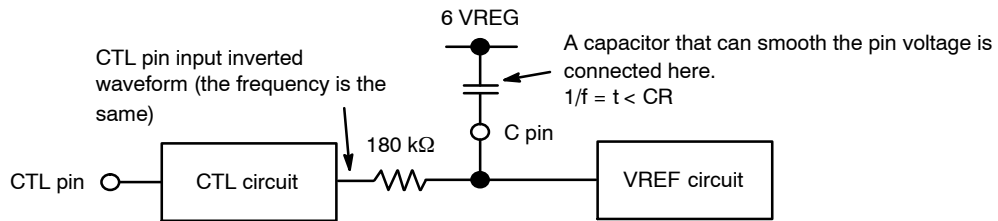

Figure 16.

# LB8503V

## APPLICATION EXAMPLE 2

[Setting the Minimum Speed for an Origin of 0% = 0 rpm]

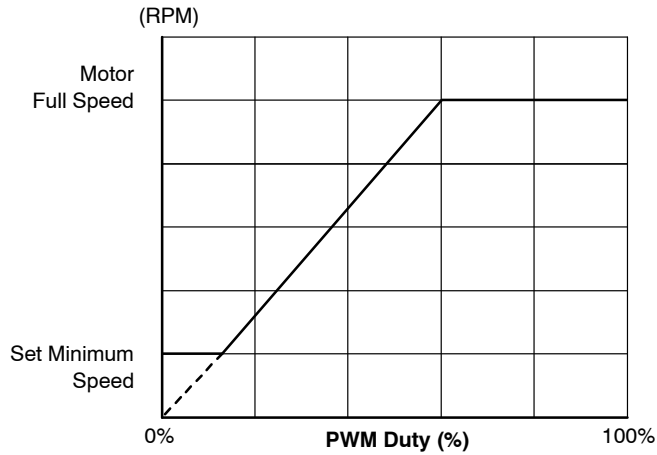

Figure 17.

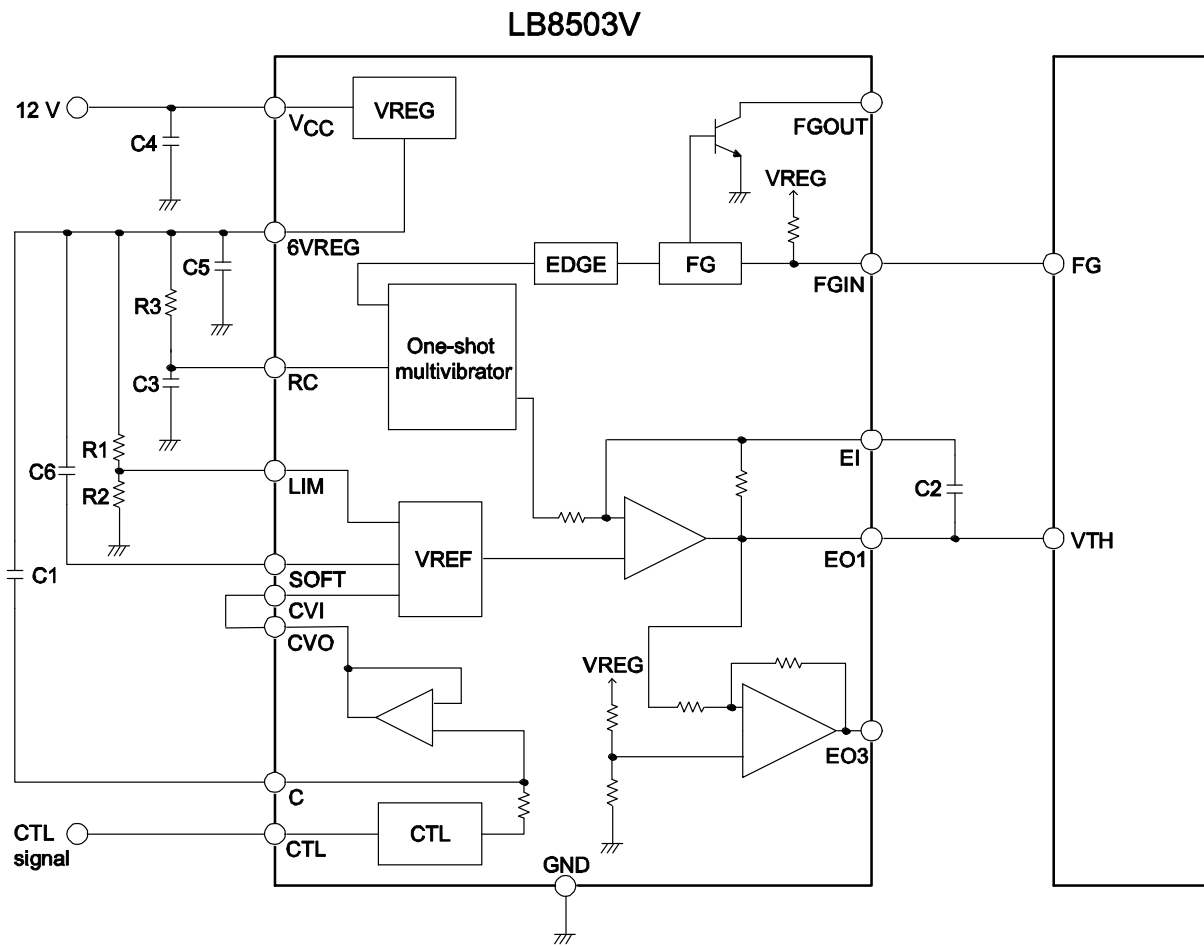

Figure 18.

When the speed control diagram origin is 0% = 0 rpm, the CVO pin is connected to the CVI pin.

If the minimum speed is not set, connect the LIM pin to the 6 VREG pin.

# LB8503V

## APPLICATION EXAMPLE 3

[Origin Shift in the Y Direction (the Motor Turns at 0%)]

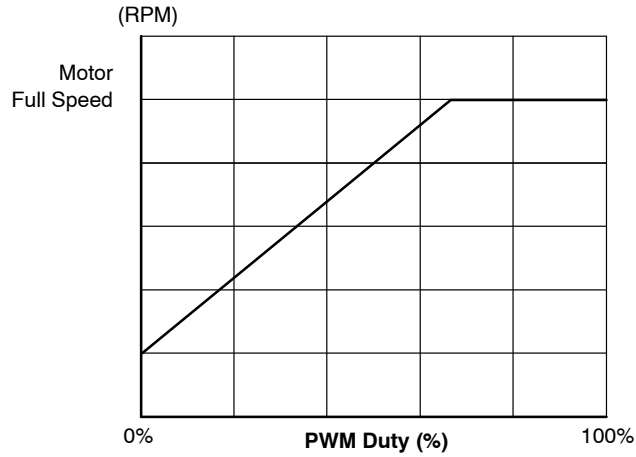

Figure 19.

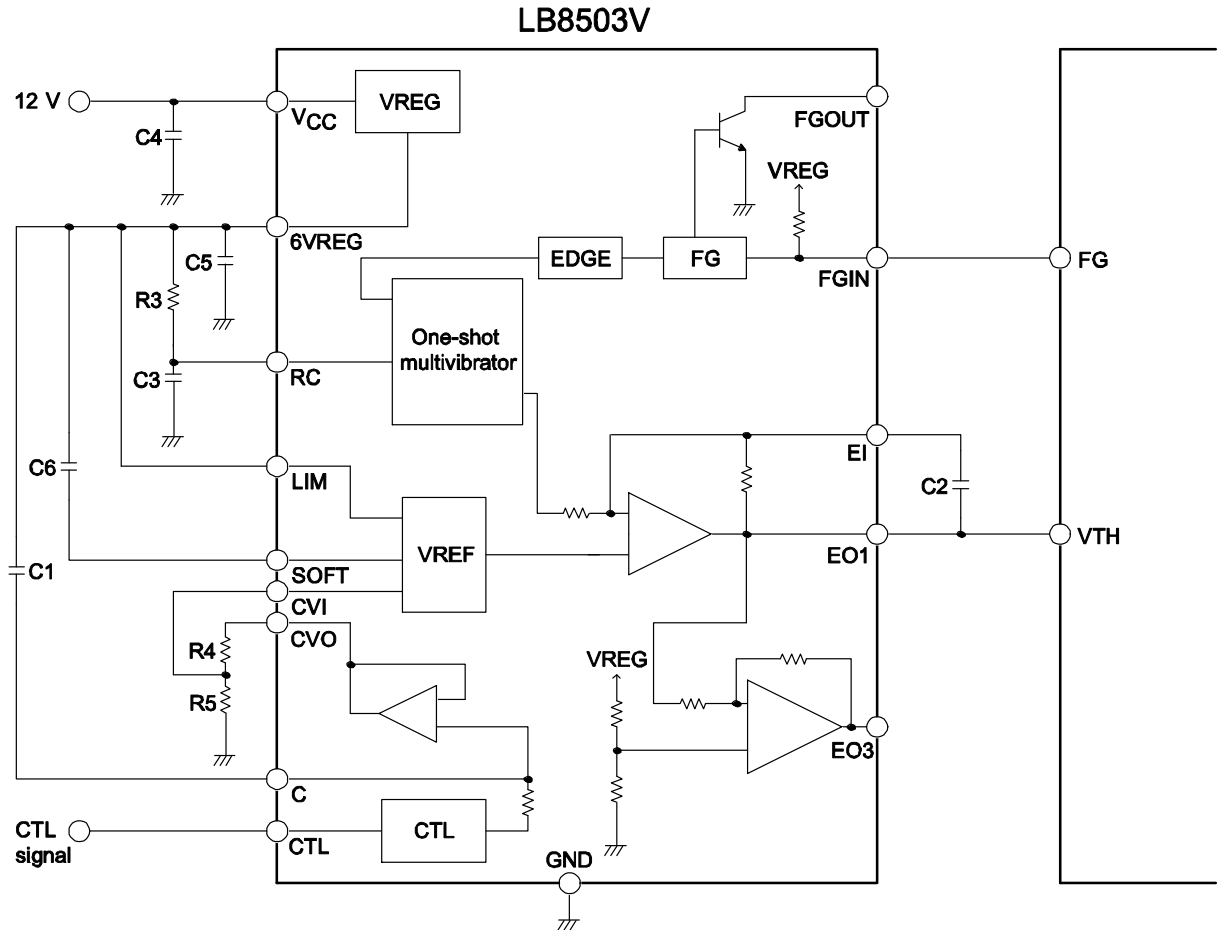

Figure 20.

When the speed control diagram origin is set so the motor turns at 0%, the CVO pin to ground potential difference is resistor divided and the midpoint is input to the CVI pin.

The speed at 0% can be changed with the resistor ratio.

# LB8503V

## APPLICATION EXAMPLE 4

[Origin Shift in the X Axis Direction (The Motor Turns at a Duty of 10% or Higher) Plus a Minimum Speed Setting]

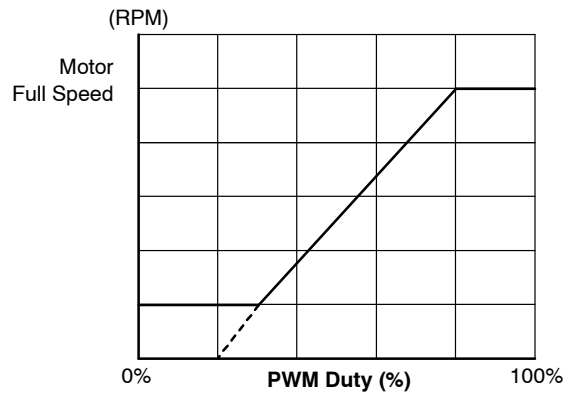

Figure 21.

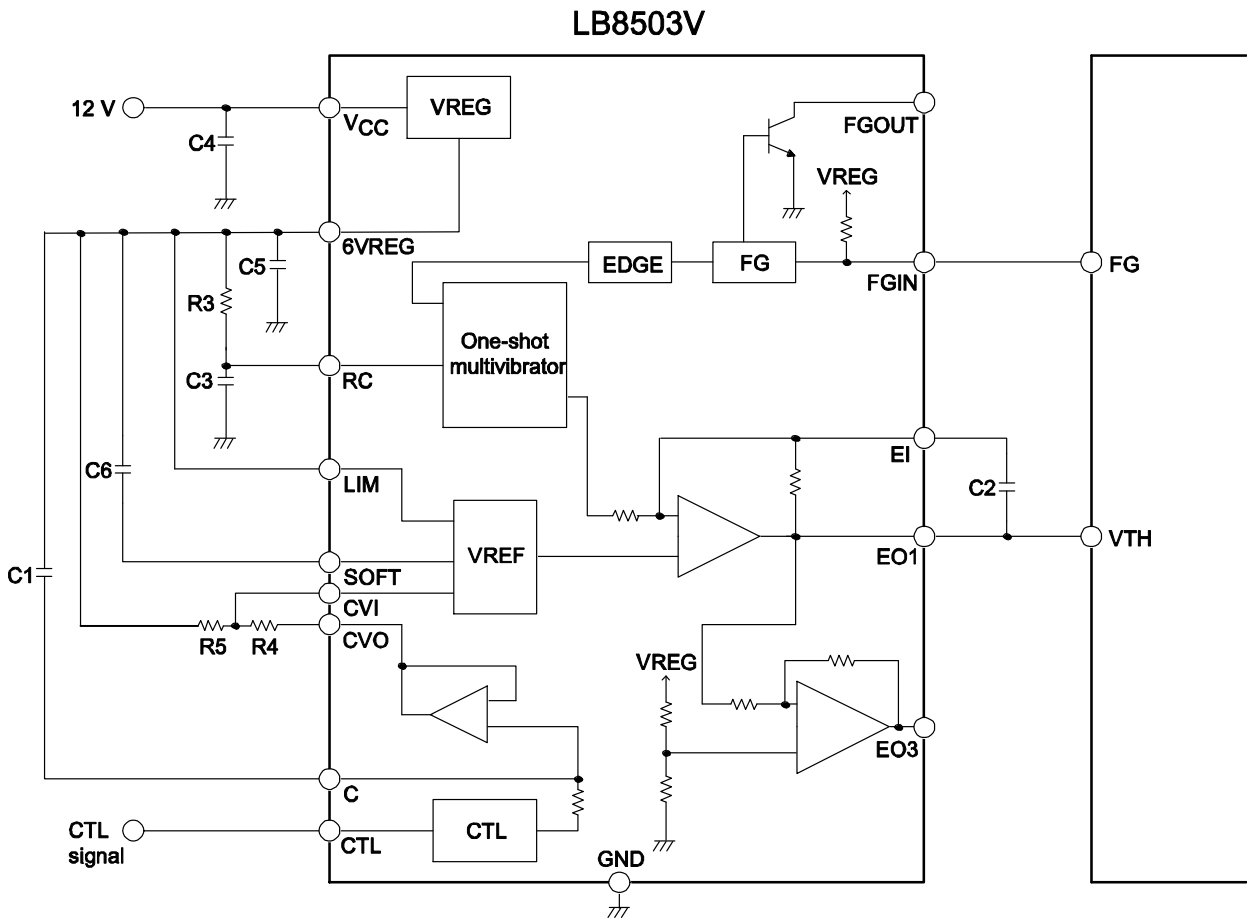

Figure 22.

When the origin in the speed control diagram is set so that the motor starts turning when the duty is above 0%, the potential difference between the CVO pin and  $V_{CC}$  is resistor divided, and that divided level is input to the CVI pin.

The duty at which rotation starts can be changed by changing the resistor ratio.

Note that the total value of the resistors R4 and R5 must exceed 100 k $\Omega$ .



# LB8503V

## APPLICATION EXAMPLE 5

### [DC Voltage Speed Control]

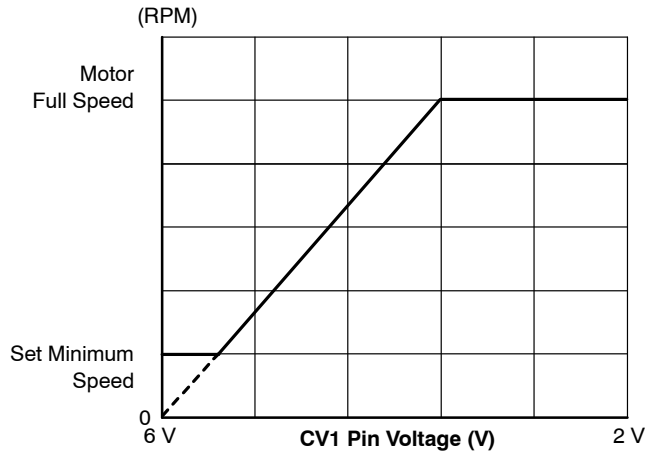

Figure 23.

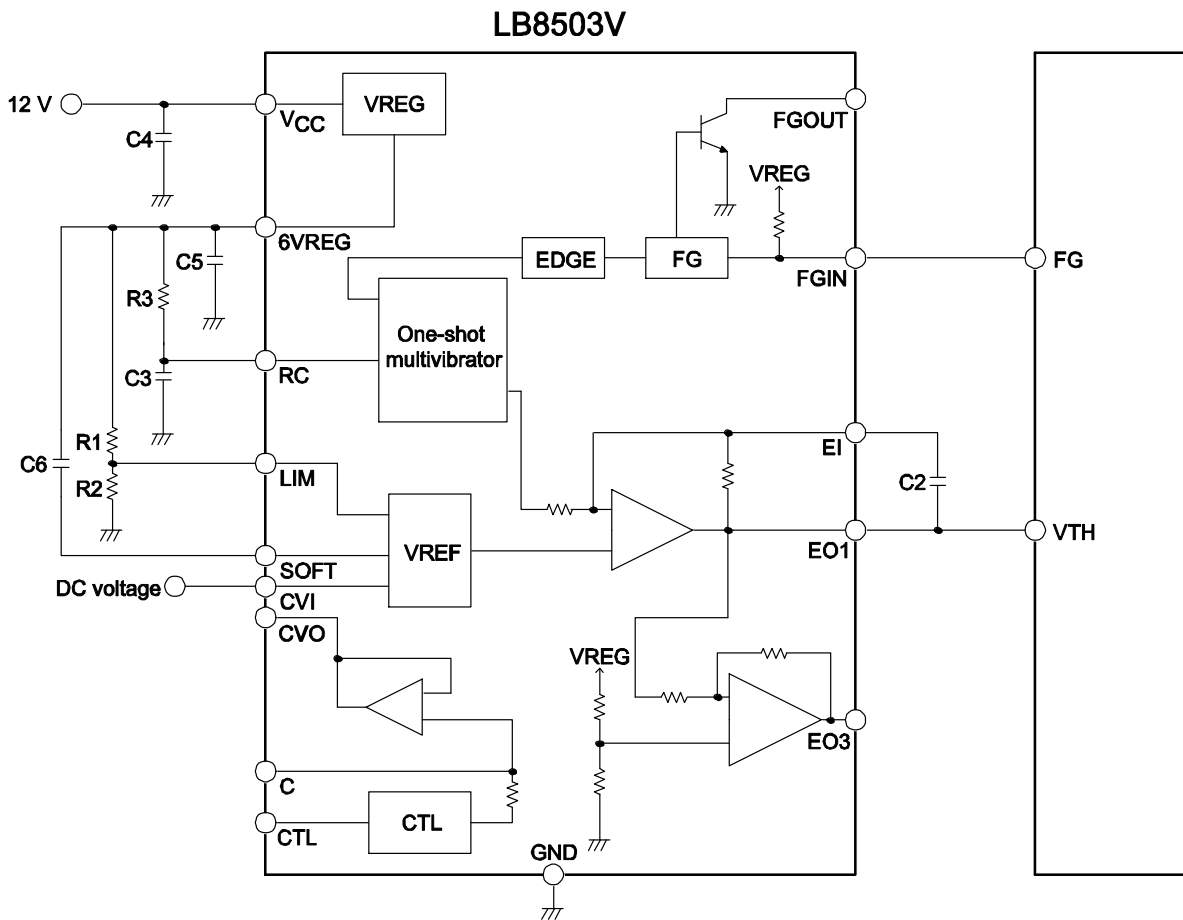

Figure 24.

When the motor speed is controlled by a DC voltage, than voltage must be in the range from 2 V to 6 VREG.

Note that the motor stops when the control voltage is at 6 VREG, and the motor speed increases as the voltage falls.

# LB8503V

## APPLICATION EXAMPLE 6

[Fixed Speed + Soft Start]

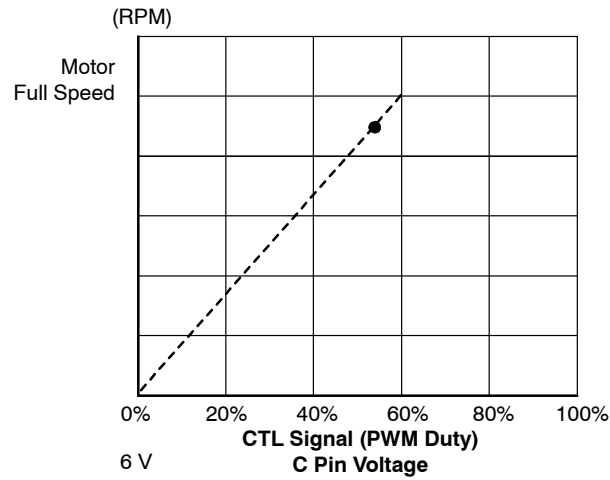

Figure 25.

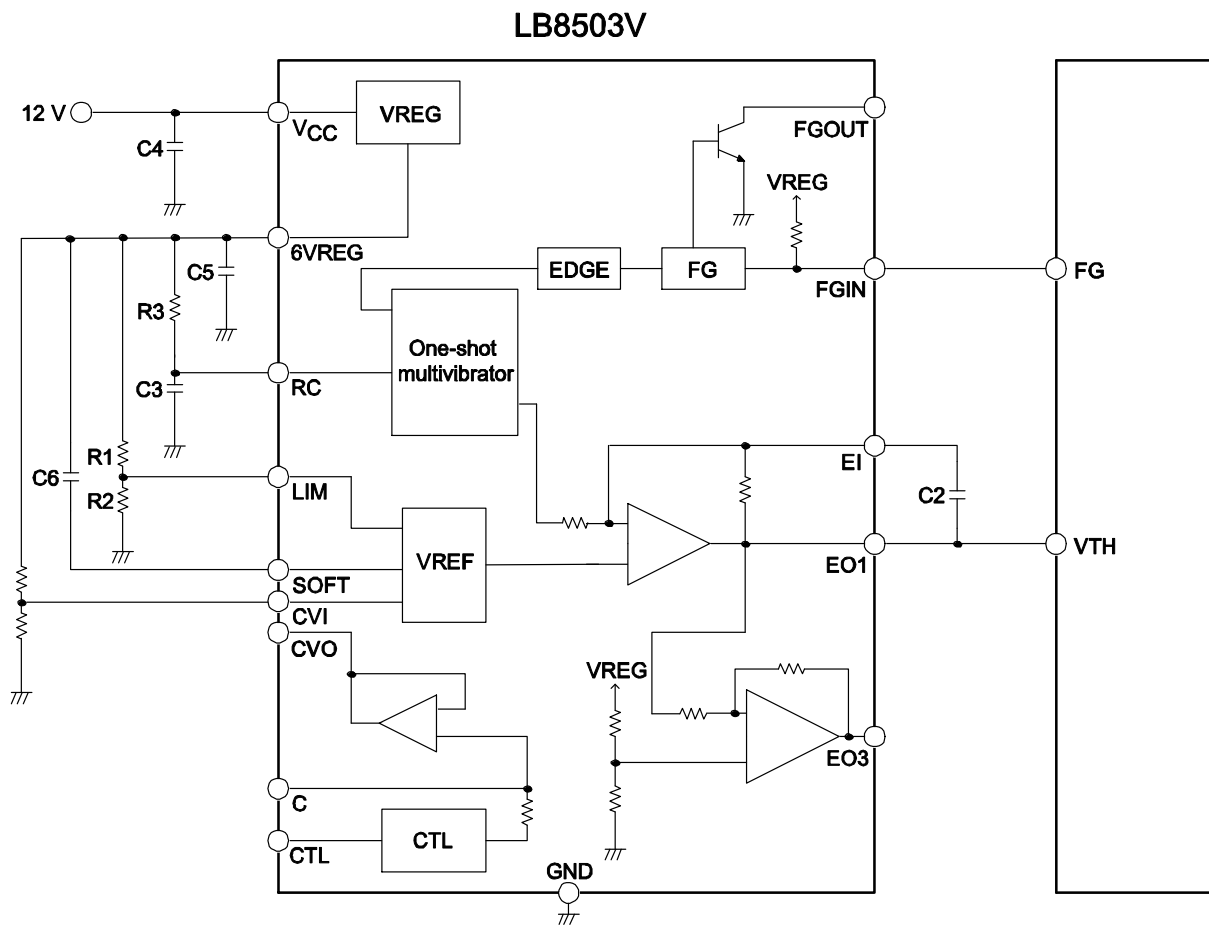

Figure 26.

With this circuit, the motor speed remains constant even if there are fluctuations in the supply voltage or static voltage. It is also possible to input a fixed-duty signal to the

CTL pin signal input as an input signal for which soft start is enabled at startup.

# LB8503V

## APPLICATION EXAMPLE 7

[Used in Combination with the LB11660FV]

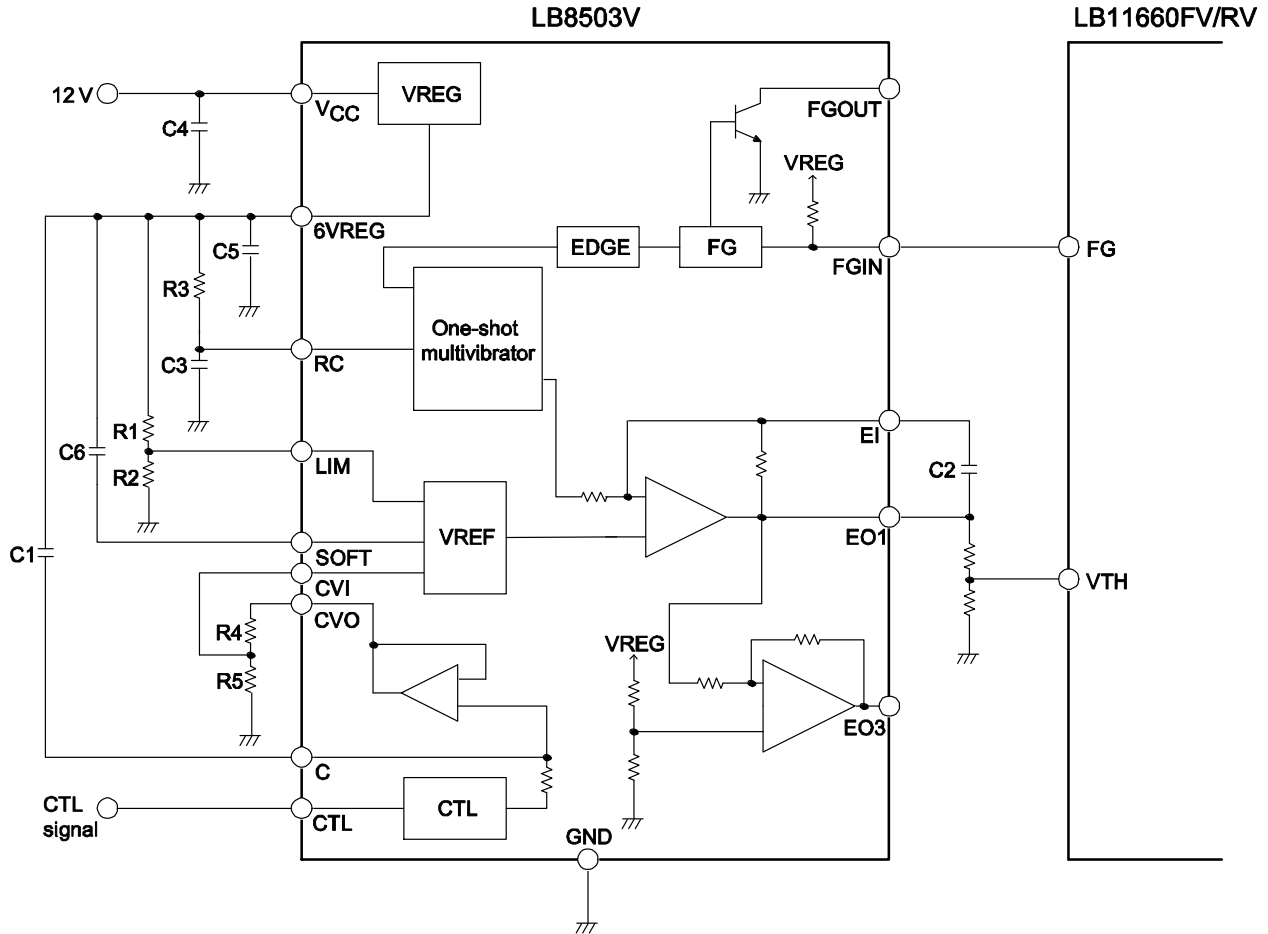

Figure 27.

In this circuit, the dynamic range of the LB8503V EO pin (the range from the amplifier block output high to output low levels) must be wider than the dynamic range (from the high to low levels of the PWM signal) of VTH pin of driver IC with which this IC is combined.

However, since the LB11660FV PWM low-level voltage is lower than the LB8503V amplifier output low-level voltage, it must be resistor divided.

# MECHANICAL CASE OUTLINE

## PACKAGE DIMENSIONS

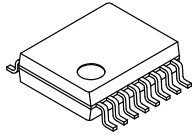

**SSOP16 (225mil)**  
**CASE 565AM**  
**ISSUE A**

DATE 23 OCT 2013

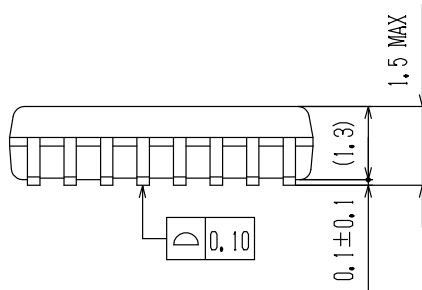
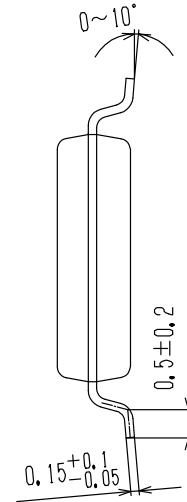
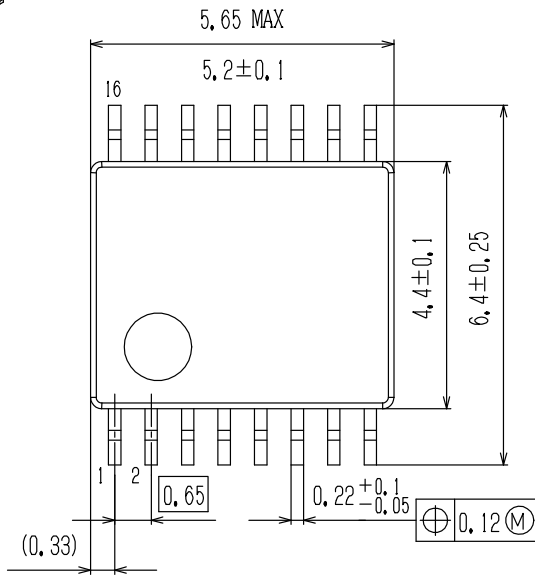

**SOLDERING FOOTPRINT\***

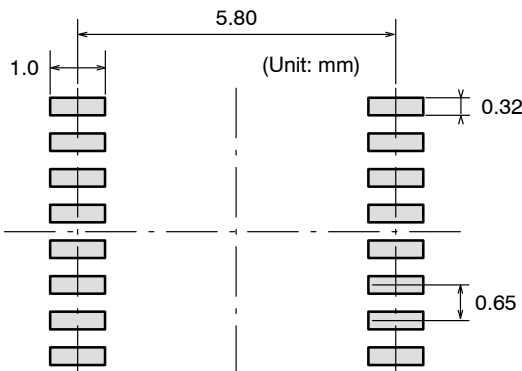

NOTE: The measurements are not to guarantee but for reference only.

\*For additional information on our Pb-Free strategy and soldering details, please download the ON Semiconductor Soldering and Mounting Techniques Reference Manual, SOLDERRM/D.

**GENERIC MARKING DIAGRAM\***

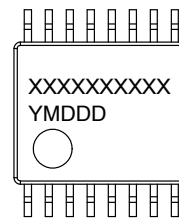

XXXXX = Specific Device Code  
 Y = Year  
 M = Month  
 DDD = Additional Traceability Data

\*This information is generic. Please refer to device data sheet for actual part marking. Pb-Free indicator, "G" or microdot "▪", may or may not be present.

<b>DOCUMENT NUMBER:</b>	<b>98AON66065E</b>	Electronic versions are uncontrolled except when accessed directly from the Document Repository. Printed versions are uncontrolled except when stamped "CONTROLLED COPY" in red.
<b>DESCRIPTION:</b>	<b>SSOP16 (225MIL)</b>	<b>PAGE 1 OF 1</b>

ON Semiconductor and are trademarks of Semiconductor Components Industries, LLC dba ON Semiconductor or its subsidiaries in the United States and/or other countries. ON Semiconductor reserves the right to make changes without further notice to any products herein. ON Semiconductor makes no warranty, representation or guarantee regarding the suitability of its products for any particular purpose, nor does ON Semiconductor assume any liability arising out of the application or use of any product or circuit, and specifically disclaims any and all liability, including without limitation special, consequential or incidental damages. ON Semiconductor does not convey any license under its patent rights nor the rights of others.

ON Semiconductor and  are trademarks of Semiconductor Components Industries, LLC dba ON Semiconductor or its subsidiaries in the United States and/or other countries. ON Semiconductor owns the rights to a number of patents, trademarks, copyrights, trade secrets, and other intellectual property. A listing of ON Semiconductor's product/patent coverage may be accessed at [www.onsemi.com/site/pdf/Patent-Marking.pdf](http://www.onsemi.com/site/pdf/Patent-Marking.pdf). ON Semiconductor reserves the right to make changes without further notice to any products herein. ON Semiconductor makes no warranty, representation or guarantee regarding the suitability of its products for any particular purpose, nor does ON Semiconductor assume any liability arising out of the application or use of any product or circuit, and specifically disclaims any and all liability, including without limitation special, consequential or incidental damages. Buyer is responsible for its products and applications using ON Semiconductor products, including compliance with all laws, regulations and safety requirements or standards, regardless of any support or applications information provided by ON Semiconductor. "Typical" parameters which may be provided in ON Semiconductor data sheets and/or specifications can and do vary in different applications and actual performance may vary over time. All operating parameters, including "Typicals" must be validated for each customer application by customer's technical experts. ON Semiconductor does not convey any license under its patent rights nor the rights of others. ON Semiconductor products are not designed, intended, or authorized for use as a critical component in life support systems or any FDA Class 3 medical devices or medical devices with a same or similar classification in a foreign jurisdiction or any devices intended for implantation in the human body. Should Buyer purchase or use ON Semiconductor products for any such unintended or unauthorized application, Buyer shall indemnify and hold ON Semiconductor and its officers, employees, subsidiaries, affiliates, and distributors harmless against all claims, costs, damages, and expenses, and reasonable attorney fees arising out of, directly or indirectly, any claim of personal injury or death associated with such unintended or unauthorized use, even if such claim alleges that ON Semiconductor was negligent regarding the design or manufacture of the part. ON Semiconductor is an Equal Opportunity/Affirmative Action Employer. This literature is subject to all applicable copyright laws and is not for resale in any manner.

## PUBLICATION ORDERING INFORMATION

### LITERATURE FULFILLMENT:

Email Requests to: [orderlit@onsemi.com](mailto:orderlit@onsemi.com)

ON Semiconductor Website: [www.onsemi.com](http://www.onsemi.com)

### TECHNICAL SUPPORT

North American Technical Support:  
Voice Mail: 1 800-282-9855 Toll Free USA/Canada  
Phone: 011 421 33 790 2910

### Europe, Middle East and Africa Technical Support:

Phone: 00421 33 790 2910

For additional information, please contact your local Sales Representative

## X-ON Electronics

Largest Supplier of Electrical and Electronic Components

*Click to view similar products for [Motor/Motion/Ignition Controllers & Drivers](#) category:*

*Click to view products by [ON Semiconductor](#) manufacturer:*

Other Similar products are found below :

[FSB50550TB2](#) [FSBF15CH60BTH](#) [MSVCPM2-63-12](#) [MSVGW45-14-2](#) [MSVGW54-14-3](#) [MSVGW54-14-5](#) [NTE7043](#) [LA6565VR-TLM-E](#)  
[LB11650-E](#) [LB1837M-TLM-E](#) [LB1845DAZ-XE](#) [LC898300XA-MH](#) [SS30-TE-L-E](#) [26700](#) [LV8281VR-TLM-H](#) [BA5839FP-E2](#) [IRAM236-1067A](#) [LA6584JA-AH](#) [LB11847L-E](#) [NCV70501DW002R2G](#) [AH293-PL-B](#) [STK672-630CN-E](#) [TND315S-TL-2H](#) [FNA23060](#) [FSB50250AB](#)  
[FNA41060](#) [MSVB54](#) [MSVBTC50E](#) [MSVCPM3-54-12](#) [MSVCPM3-63-12](#) [MSVCPM4-63-12](#) [MSVTA120](#) [FSB50550AB](#)  
[NCV70501DW002G](#) [LC898301XA-MH](#) [LV8413GP-TE-L-E](#) [MSVGW45-14-3](#) [MSVGW45-14-4](#) [MSVGW45-14-5](#) [MSVGW54-14-4](#)  
[STK984-091A-E](#) [MP6519GQ-Z](#) [LB11651-E](#) [IRSM515-025DA4](#) [LV8127T-TLM-H](#) [MC33812EKR2](#) [NCP81382MNTXG](#) [TDA21801](#)  
[LB11851FA-BH](#) [NCV70627DQ001R2G](#)