

# LC75852E, LC75852W

## 1/2-Duty LCD Driver with Key Input Function



ON Semiconductor®

www.onsemi.com

### Overview

The LC75852E and LC75852W are 1/2 duty dynamic LCD display drivers. In addition to being able to directly drive LCD panels with up to 90 segments, they can also control up to four general-purpose output ports. These products also include a key scan circuit which allows them to accept input from keypads with up to 30 keys. This allows end product front panel wiring to be simplified.

### Features

- Up to 30 key inputs (Key scan is only performed when a key is pressed.)
- 1/2 duty – 1/2 bias (up to 90 segments)
- Sleep mode and the all segments off function can be controlled from serial data.
- Segment output port/general-purpose output port usage can be controlled from serial data.
- Serial data I/O supports CCB\* format communication with the system controller.
- High generality since display data is displayed directly without decoder intervention
- Reset pin that can establish the initial state.

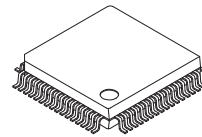

PQFP64 14x14 / Q1P64E  
[LC75852E]

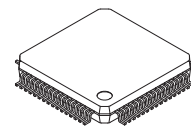

SPQFP64 10x10 / SQFP64  
[LC75852W]

### Specifications

**Absolute Maximum Ratings** at  $T_a = 25^\circ\text{C}$ ,  $V_{SS} = 0\text{V}$

Parameter	Symbol	Conditions	Ratings	Unit
Maximum supply voltage	$V_{DD\ max}$	$V_{DD}$	-0.3 to +7.0	V
Input voltage	$V_{IN}$	OSC, CE, CL, DI, $\overline{RES}$ , KI1 to KI5	-0.3 to $V_{DD}+0.3$	V
Output voltage	$V_{OUT}$	OSC, DO, S1 to S45, COM1, COM2, KS1 to KS6, P1 to P4	-0.3 to $V_{DD}+0.3$	V
Output current	$I_{OUT1}$	S1 to S45	100	$\mu\text{A}$
	$I_{OUT2}$	COM1, COM2, KS1 to KS6	1	mA
	$I_{OUT3}$	P1 to P4	5	
Allowable power dissipation	$P_d\ max$	$T_a = 85^\circ\text{C}$	200	mW
Operating temperature	$T_{opr}$		-40 to +85	$^\circ\text{C}$
Storage temperature	$T_{stg}$		-55 to +125	$^\circ\text{C}$

Stresses exceeding those listed in the Maximum Ratings table may damage the device. If any of these limits are exceeded, device functionality should not be assumed, damage may occur and reliability may be affected.

\* Computer Control Bus (CCB) is an ON Semiconductor's original bus format and the bus addresses are controlled by ON Semiconductor.

### ORDERING INFORMATION

See detailed ordering and shipping information on page 19 of this data sheet.

# LC75852E, LC75852W

## Allowable Operating Ranges at $T_a = -40$ to $+85^\circ\text{C}$ , $V_{SS} = 0$ V

Parameter	Symbol	Conditions	min	typ	max	Unit
Supply voltage	$V_{DD}$	$V_{DD}$	4.5		6.0	V
Input high-level voltage	$V_{IH1}$	CE, CL, DI, $\overline{\text{RES}}$	$0.8 V_{DD}$		$V_{DD}$	V
	$V_{IH2}$	KI1 to KI5	$0.6 V_{DD}$		$V_{DD}$	V
Input low-level voltage	$V_{IL}$	CE, CL, DI, $\overline{\text{RES}}$ , KI1 to KI5	0		$0.2 V_{DD}$	V
Recommended external resistance	$R_{OSC}$	OSC		62		k $\Omega$
Recommended external capacitance	$C_{OSC}$	OSC		680		pF
Guaranteed oscillator range	$f_{OSC}$	OSC	25	50	100	kHz
Data setup time	$t_{ds}$	CL, DI: Figure 1	160			ns
Data hold time	$t_{dh}$	CL, DI: Figure 1	160			ns
CE wait time	$t_{cp}$	CE, CL: Figure 1	160			ns
CE setup time	$t_{cs}$	CE, CL: Figure 1	160			ns
CE hold time	$t_{ch}$	CE, CL: Figure 1	160			ns
High-level clock pulse width	$t_{bH}$	CL: Figure 1	160			ns
Low-level clock pulse width	$t_{bL}$	CL: Figure 1	160			ns
Rise time	$t_r$	CE, CL, DI: Figure 1		160		ns
Fall time	$t_f$	CE, CL, DI: Figure 1		160		ns
DO output delay time	$t_{dc}$	DO, $R_{PU} = 4.7$ k $\Omega$ , $C_L = 10$ pF*: Figure 1			1.5	$\mu\text{s}$
DO rise time	$t_{dr}$	DO, $R_{PU} = 4.7$ k $\Omega$ , $C_L = 10$ pF*: Figure 1			1.5	$\mu\text{s}$
$\overline{\text{RES}}$ switching time	t2	Figure 2	10			$\mu\text{s}$

Note: \* Since DO is an open-drain output, these values differ depending on the pull-up resistor  $R_{PU}$  and the load capacitance  $C_L$ .

Functional operation above the stresses listed in the Recommended Operating Ranges is not implied. Extended exposure to stresses beyond the Recommended Operating Ranges limits may affect device reliability.

## Electrical Characteristics in the Allowable Operating Ranges

Parameter	Symbol	Conditions	min	typ	max	Unit
Hysteresis	$V_H$	CE, CL, DI, $\overline{\text{RES}}$ , KI1 to KI5		$0.1 V_{DD}$		V
Input high-level current	$I_{IH}$	CE, CL, DI, $\overline{\text{RES}}$ : $V_I = 6.0$ V			5.0	$\mu\text{A}$
Input low-level current	$I_{IL}$	CE, CL, DI, $\overline{\text{RES}}$ : $V_I = 0$ V	-5.0			$\mu\text{A}$
Input floating voltage	$V_{IF}$	KI1 to KI5			$0.05 V_{DD}$	V
Pull-down resistance	$R_{PD}$	KI1 to KI5: $V_{DD} = 5.0$ V	50	100	250	k $\Omega$
Output off leakage current	$I_{OFFH}$	DO: $V_O = 6.0$ V			6.0	$\mu\text{A}$
Output high-level voltage	$V_{OH1}$	KS1 to KS6: $I_O = -1$ mA	$V_{DD} - 1.0$			V
	$V_{OH2}$	P1 to P4: $I_O = -1$ mA	$V_{DD} - 1.0$			V
	$V_{OH3}$	S1 to S45: $I_O = -10$ $\mu\text{A}$	$V_{DD} - 1.0$			V
	$V_{OH4}$	COM1, COM2: $I_O = -100$ $\mu\text{A}$	$V_{DD} - 0.6$			V
Output low-level voltage	$V_{OL1}$	KS1 to KS6: $I_O = 50$ $\mu\text{A}$	0.4	1.0	3.0	V
	$V_{OL2}$	P1 to P4: $I_O = 1$ mA			1.0	V
	$V_{OL3}$	S1 to S45: $I_O = 10$ $\mu\text{A}$			1.0	V
	$V_{OL4}$	COM1, COM2: $I_O = 100$ $\mu\text{A}$			0.6	V
	$V_{OL5}$	DO: $I_O = 1$ mA		0.1	0.5	V
Output middle-level voltage	$V_{MID1}$	COM1, COM2: $V_{DD} = 6.0$ V, $I_O = \pm 100$ $\mu\text{A}$	2.4	3.0	3.6	V
	$V_{MID2}$	COM1, COM2: $V_{DD} = 4.5$ V, $I_O = \pm 100$ $\mu\text{A}$	1.65	2.25	2.85	V
Current drain	$I_{DD1}$	Sleep mode, $T_a = 25^\circ\text{C}$			5	$\mu\text{A}$
	$I_{DD2}$	$V_{DD} = 6.0$ V, output open, $T_a = 25^\circ\text{C}$ , $f_{OSC} = 50$ kHz		1.4	2.5	mA

Product parametric performance is indicated in the Electrical Characteristics for the listed test conditions, unless otherwise noted. Product performance may not be indicated by the Electrical Characteristics if operated under different conditions.

1. When stopped with CL at the low level

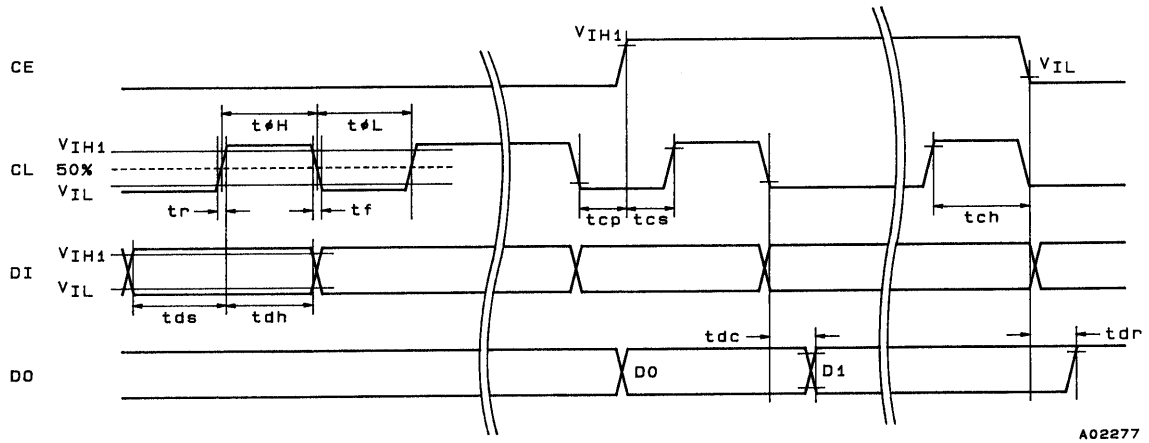

A02277

2. When stopped with CL at the high level

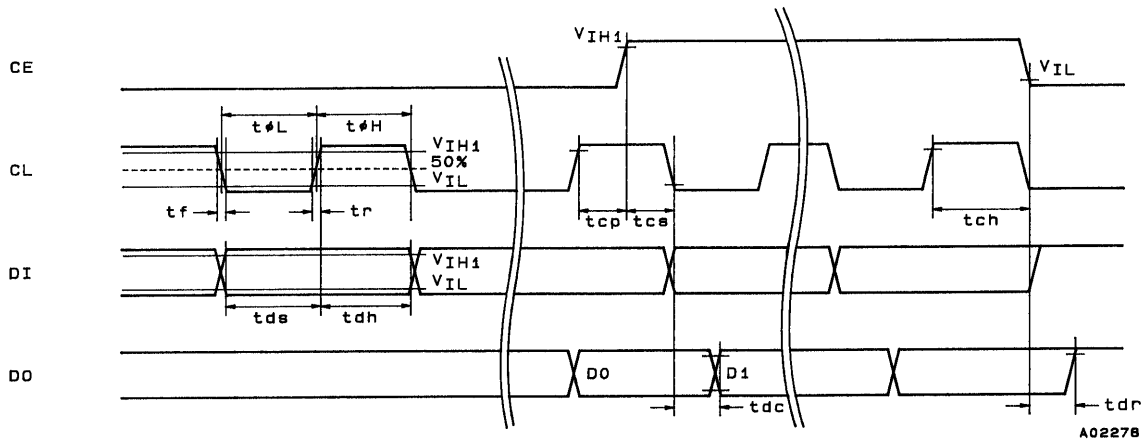

A02278

Figure 1

Pin Assignment

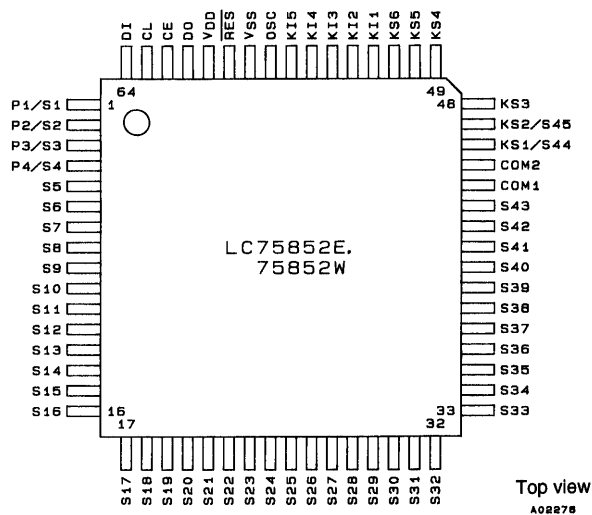

Top view  
A02278

Block Diagram

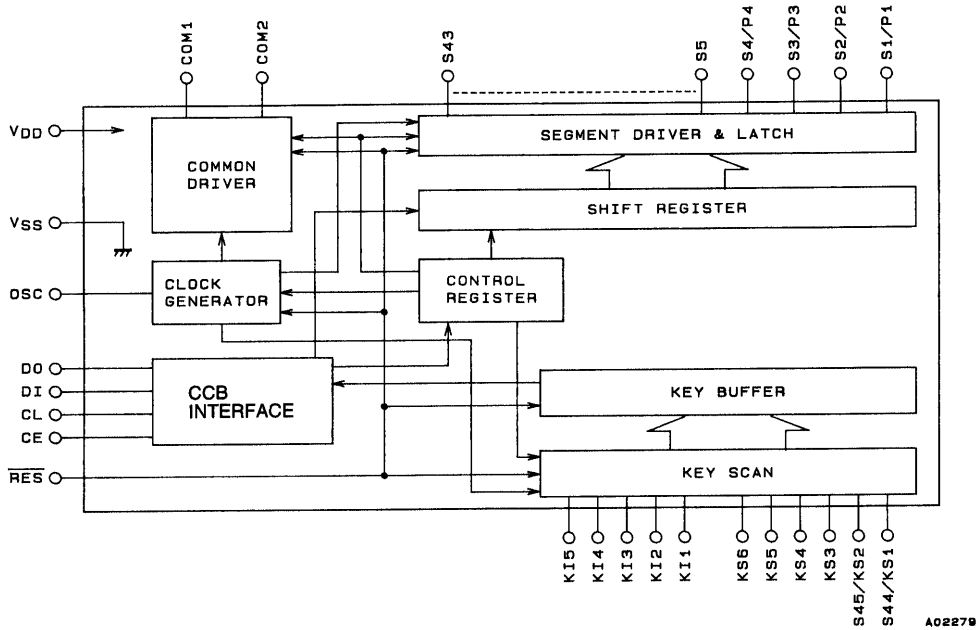

Pin Functions

Pin	Pin No.	Function	Active	I/O	Handling when unused
S1/P1 to S4/P4 S5 to S43	1 to 4 5 to 43	Segment outputs: Used to output the display data that is transmitted over the serial data input. Pins S1/P1 to S4/P4 can be used as general-purpose outputs according to control data specification.	—	O	Open
COM1 COM2	44 45	Common driver outputs. The frame frequency $f_o$ is ( $f_{osc}/512$ ) Hz.	—	O	Open
KS1/S44, KS2/S45, KS3 to KS6	46 47 48 to 51	Key scan outputs. When a key matrix is formed, normally a diode will be attached to the key scan timing line to prevent shorts. However, since the output transistor impedance is an unbalanced CMOS output, it will not be damaged if shorted. Pins KS1/S44 and KS2/S45 can be used as segment outputs according to control data specification.	—	O	Open
KI1 to KI5	52 to 56	Key scan inputs: Pins with a built-in pull-down resistor.	H	I	GND
OSC	57	Oscillator connection: Oscillator circuit can be formed by connecting the pin to a resistor and a capacitor.	—	I/O	V <sub>DD</sub>
CE CL DI DO	62 63 64 61	Serial data interface: Connected to the controller. Since DO is an open-drain output, it requires a pull-up resistor. CE: Chip enable CL: Synchronization clock DI: Transfer data DO: Output data	H — — —	I I I O	GND GND Open
$\overline{RES}$	59	Reset input that re-initializes the LSI internal states. During a reset, the display segments are turned off forcibly regardless of the internal display data. All internal key data is reset to low and the key scan operation is disabled. However, serial data can be input during a reset.	L	I	GND
V <sub>DD</sub>	60	Power supply connection. A supply voltage of between 4.5 and 6.0 V must be provided.	—	—	—
V <sub>SS</sub>	58	Power supply ground connection. Must be connected to GND.	—	—	—

Serial Data Input

1. When stopped with CL at the low level

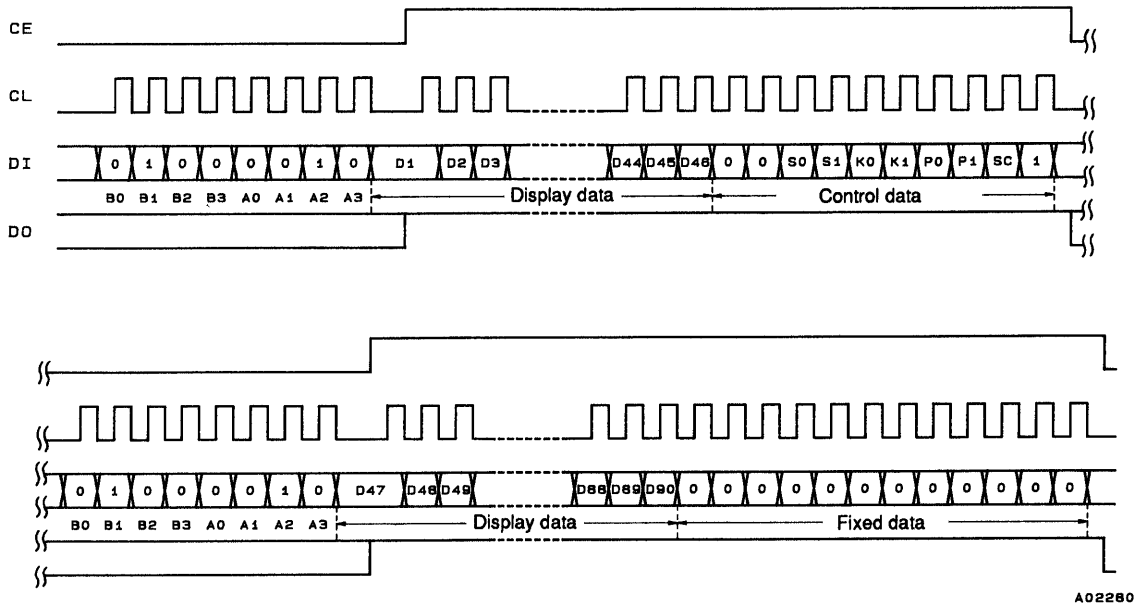

2. When stopped with CL at the high level

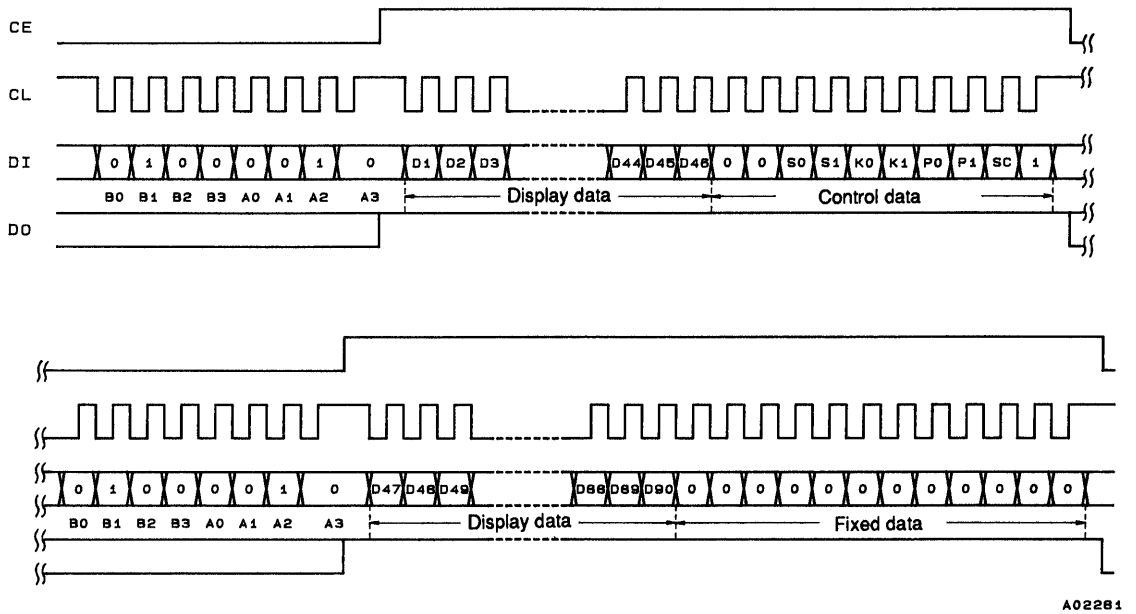

- CCB address .....[42H]
- D1 to D90 .....Display data
- S0, S1 .....Sleep control data
- K0, K1 .....Key scan output/segment output selection data
- P0, P1 .....Segment output port/general-purpose output port selection data
- SC .....Segment on/off control data

**Control Data Functions**

1. S0, S1 .....Sleep control data

This control data switches the LSI between normal mode and sleep mode. It also sets the key scan output standby states for pins KS1 to KS6.

Control data		Mode	Oscillator	Segment outputs Common outputs	Key scan standby mode output pin states					
S0	S1				KS1	KS2	KS3	KS4	KS5	KS6
0	0	Normal	Oscillator	Operation	H	H	H	H	H	H
0	1	Sleep	Stopped	L	L	L	L	L	L	H
1	0	Sleep	Stopped	L	L	L	L	L	H	H
1	1	Sleep	Stopped	L	H	H	H	H	H	H

Note: The KS1/S44 and KS2/S45 output pins are set to the key scan output state.

2. K0, K1 .....Key scan output/segment output selection data

This control data switches the KS1/S44 and KS2/S45 output pins between the key scan output and segment output functions.

Control data		Output pin states		Maximum number of key inputs
K0	K1	KS1/S44	KS2/S45	
0	0	KS1	KS2	30
0	1	S44	KS2	25
1	X	S44	S45	20

X: don't care

3. P0, P1 .....Segment output port/general-purpose output port selection data

This control data switches the S1/P1 to S4/P4 output pins between the segment output port and the general-purpose output port functions.

Control data		Output pin states			
P0	P1	S1/P1	S2/P2	S3/P3	S4/P4
0	0	S1	S2	S3	S4
0	1	P1	P2	S3	S4
1	0	P1	P2	P3	S4
1	1	P1	P2	P3	P4

The table below lists the correspondence between the display data and the output pins when the general-purpose output port function is selected.

Output pin	Corresponding display data
S1/P1	D1
S2/P2	D3
S3/P3	D5
S4/P4	D7

For example, if the output pin S4/P4 is set for use as a general-purpose output port, the output pin S4/P4 will output a high level when the display data D7 is 1.

4. SC .....Segment on/off control data

This control data controls the segment on/off states.

SC	Display state
0	On
1	Off

**Display Data and Output Pin Correspondences**

Output pin	COM1	COM2
S1/P1	D1	D2
S2/P2	D3	D4
S3/P3	D5	D6
S4/P4	D7	D8
S5	D9	D10
S6	D11	D12
S7	D13	D14
S8	D15	D16
S9	D17	D18
S10	D19	D20
S11	D21	D22
S12	D23	D24
S13	D25	D26
S14	D27	D28
S15	D29	D30
S16	D31	D32
S17	D33	D34
S18	D35	D36
S19	D37	D38
S20	D39	D40
S21	D41	D42
S22	D43	D44
S23	D45	D46
S24	D47	D48
S25	D49	D50
S26	D51	D52
S27	D53	D54
S28	D55	D56
S29	D57	D58
S30	D59	D60
S31	D61	D62
S32	D63	D64
S33	D65	D66
S34	D67	D68
S35	D69	D70
S36	D71	D72
S37	D73	D74
S38	D75	D76
S39	D77	D78
S40	D79	D80
S41	D81	D82
S42	D83	D84
S43	D85	D86
KS1/S44	D87	D88
KS2/S45	D89	D90

For example, the output states of output pin S11 are listed in the table below.

Display data		Output pin state
D21	D22	S11
0	0	Segment off for both COM1 and COM2
0	1	Segment on for COM2
1	0	Segment on for COM1
1	1	Segments on for both COM1 and COM2

**Serial Data Output**

1. When stopped with CL at the low level

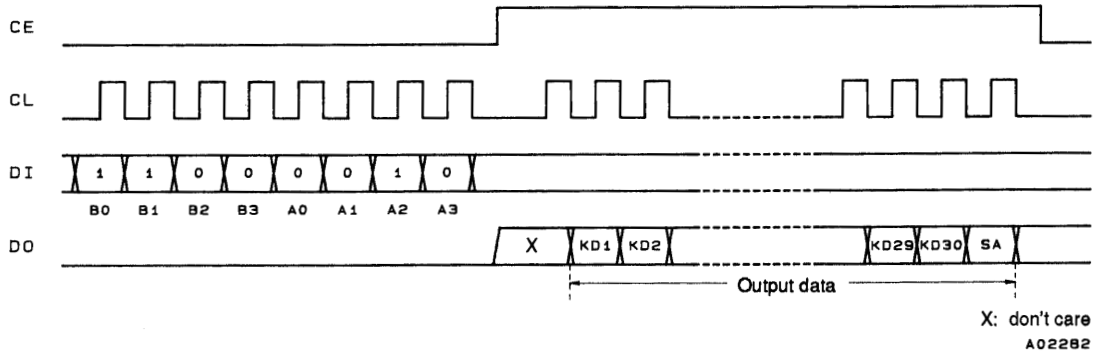

2. When stopped with CL at the high level

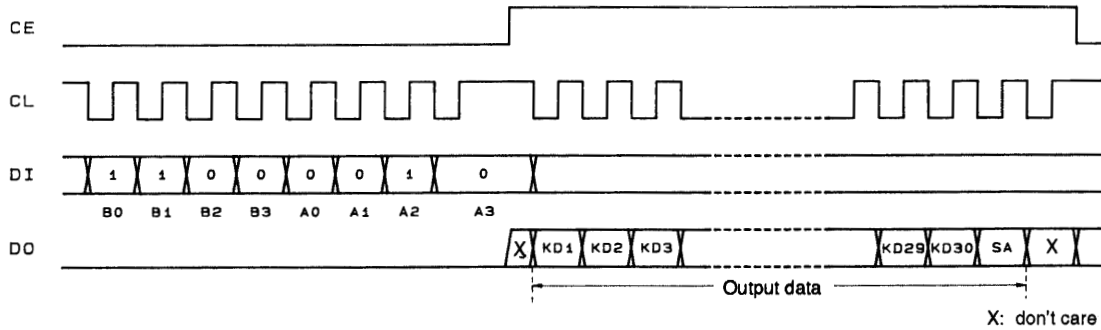

CCB address .....[43H]  
 KD1 to KD30 .....Key data  
 SA .....Sleep acknowledge data

Note: If key data is read when DO is high, the key data (KD1 to KD30) and sleep acknowledge data (SA) will be invalid.

**Output Data**

1. KD1 to KD30.....Key data

When a key matrix with up to 30 keys is formed using the KS1 to KS6 output pins and the KI1 to KI5 input pins, the key data corresponding to a given key will be 1 if that key is pressed. The table below lists that correspondence.

Item	KI1	KI2	KI3	KI4	KI5
KS1/S44	KD1	KD2	KD3	KD4	KD5
KS2/S45	KD6	KD7	KD8	KD9	KD10
KS3	KD11	KD12	KD13	KD14	KD15
KS4	KD16	KD17	KD18	KD19	KD20
KS5	KD21	KD22	KD23	KD24	KD25
KS6	KD26	KD27	KD28	KD29	KD30

When the output pins KS1/S44 and KS2/S45 are selected for segment output by the control data K0 and K1, the key data items KD1 to KD10 will be 0.

2. SA .....Sleep acknowledge data

This output data is set according to the state when the key was pressed. If the LSI was in sleep mode, SA will be 1, and if the LSI was in normal mode, SA will be 0.

**Sleep Mode**

When S0 or S1 in the control data is set to 1, the oscillator at the OSC pin will stop (it will restart if a key is pressed) and the segment and common outputs will all go to the low level. This reduces the LSI power dissipation. However, the S1/P1 to S4/P4 output pins can be used as general-purpose output ports even in sleep mode if selected for such use by the P0 and P1 control data bits.



## Key Scan Operation

### 1. Key Scan Timing

The key scan period is  $375T$  [s]. The key scan is performed twice to reliably determine the key on/off states, and the LSI detects key data agreement. When the key data agrees, the LSI determines that a key has been pressed, and outputs a key read request (by setting DO low)  $800T$  [s] after the key scan started. If a key is pressed again without the key data agreeing, a key scan is performed once more. Thus key on/off operations shorter than  $800T$  [s] cannot be detected.

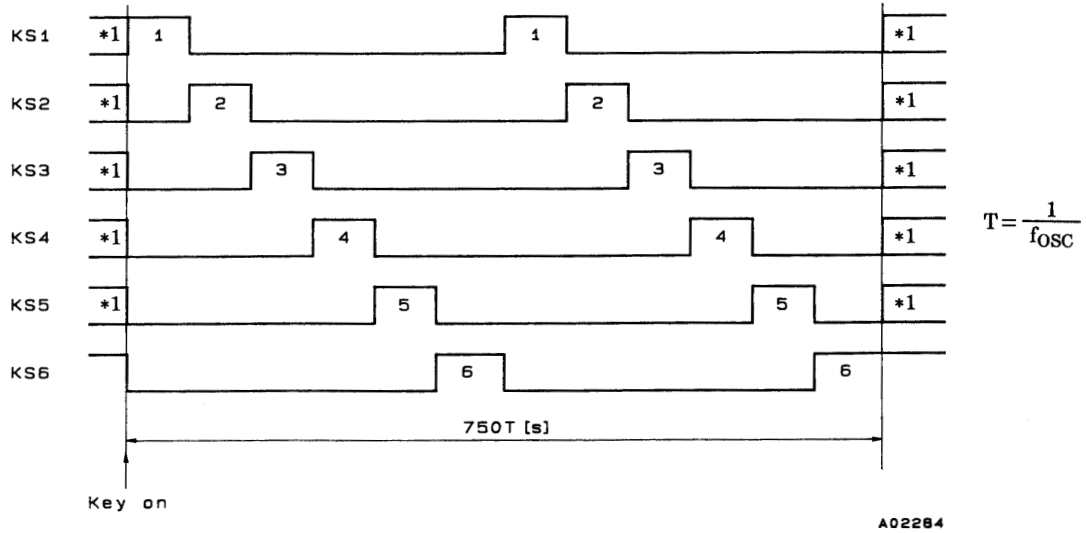

\*1 The high or low states of these signals in sleep mode are determined by the S0 and S1 control data bits.

### 2. Key Scan during Normal Mode

- The pins KS1 to KS6 are set high.
- A key scan starts if any key is pressed, and the scan continues until all keys have been released. Multiple key presses can be recognized by determining if multiple key data bits have been set.
- When a key has been pressed for  $800T$  [s] (where  $T = 1/f_{OSC}$ ) or longer, a key data read request (DO is set to low) is output to the controller. The controller acknowledges this request and reads the key data. However, DO will go high when CE is high during a serial data transfer.
- After the controller has finished reading the key data, the LSI clears the key data read request (by setting DO high) and performs another key scan. Note that since DO is an open drain output, a pull-up resistor of between 1 and 10 k $\Omega$  is required.

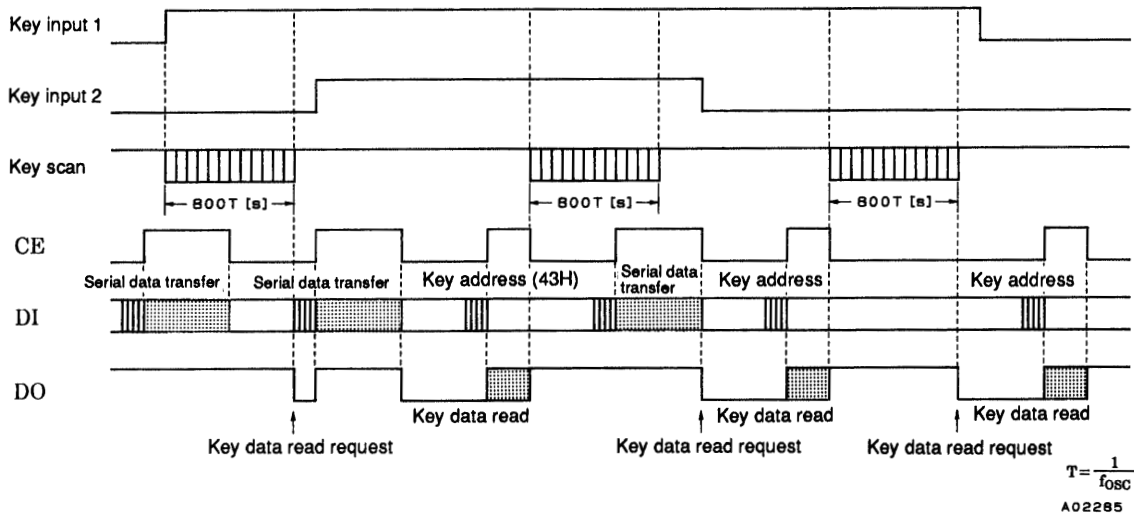

3. Key Scan during Sleep Mode

- The pins KS1 to KS6 are set high or low according to the S0 and S1 control data bits.  
(See the description of the control data function for details.)
- If a key for a line corresponding to one of the pins KS1 to KS6 which is high is pressed, the oscillator at the OSC pin starts and a key scan is performed. The key scan continues until all keys have been released. Multiple key presses can be recognized by determining if multiple key data bits have been set.
- When a key has been pressed for  $800T$  [s] (where  $T = 1/f_{OSC}$ ) or longer, a key data read request (DO is set to low) is output to the controller. The controller acknowledges this request and reads the key data. However, DO will go high when CE is high during a serial data transfer.
- After the controller has finished reading the key data, the LSI clears the key data read request (by setting DO high) and performs another key scan. Note that since DO is an open drain output, a pull-up resistor of between 1 and 10 kΩ is required.
- Key scan example in sleep mode

Example: Here  $S0 = 0$  and  $S1 = 1$  (This is a sleep in which only KS6 is high.)

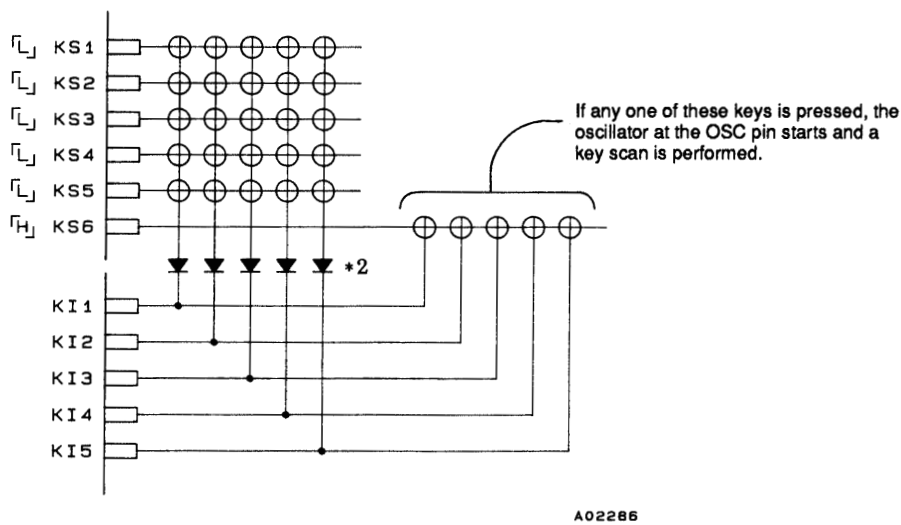

\*2: These diodes are required to reliably recognize events in which three or more of the keys on the KS6 line are pressed at the same time.

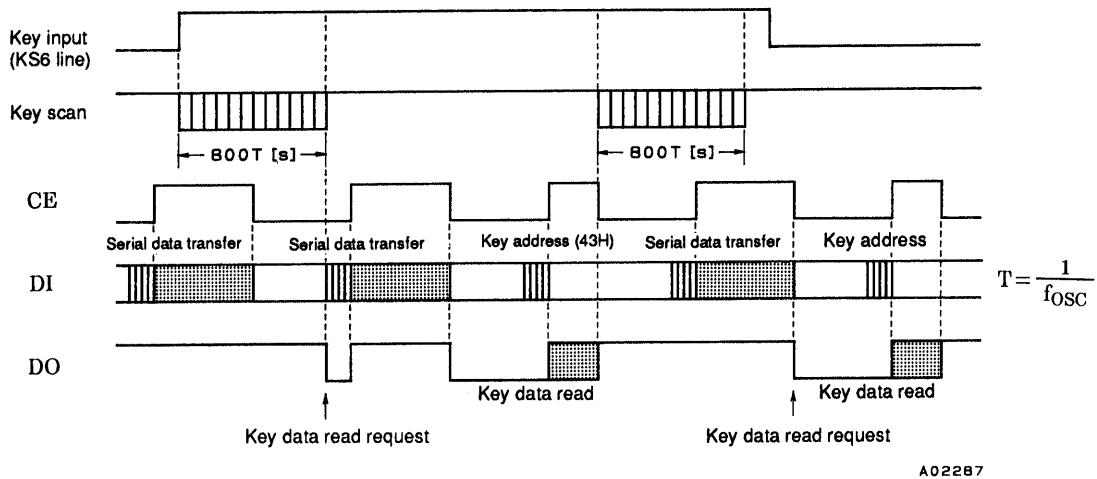

**Multiple Key Presses**

Without the insertion of additional diodes, the LC75852 supports key scan for double key presses in general, triple key presses of keys on the lines for input pins KI1 to KI5, and multiple key presses of keys on the lines for the output pins KS1 to KS6. However, if multiple key presses in excess of these limits occur, the LC75852 may recognize keys that were not pressed as having been pressed. Therefore, series diodes must be connected to each key.

1/2 Duty - 1/2 Bias LCD Drive Scheme

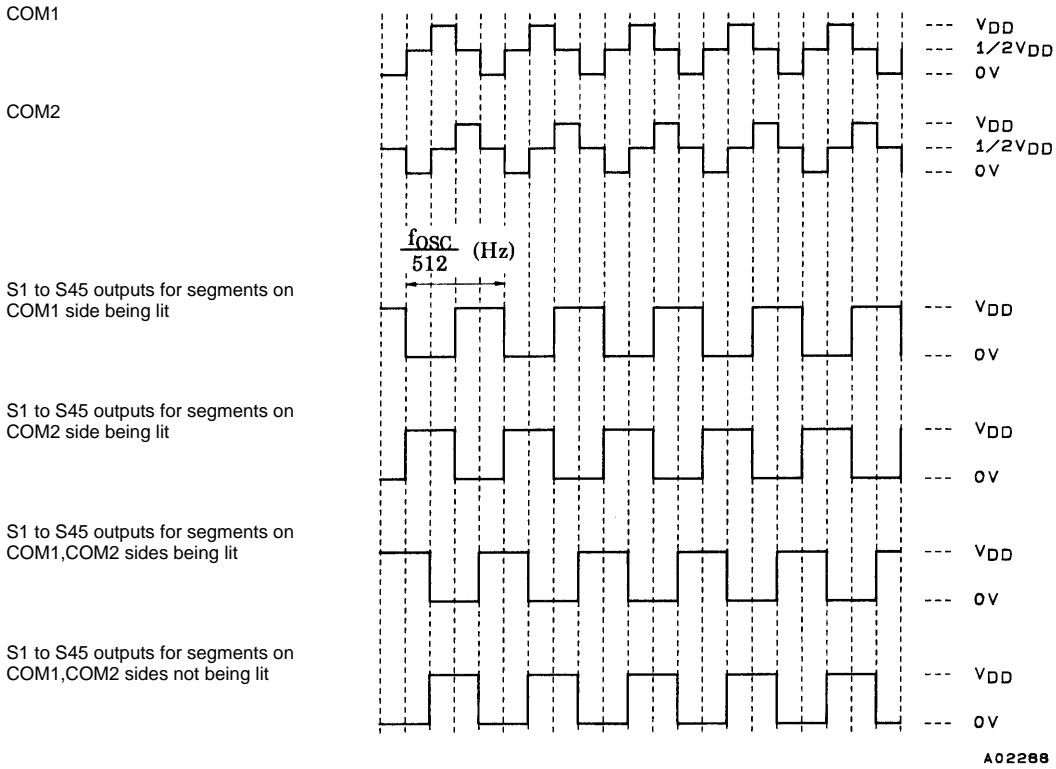

$\overline{\text{RES}}$  and the Display Controller

Since the LSI internal data (D1 to D90 and the control data) is undefined when power is first applied, the output pins S1/P1 to S4/P4, S5 to S43, COM1, COM2, KS1/S44 and KS2/S45 should be held low by setting the  $\overline{\text{RES}}$  pin low at the same time as power is applied. Then, meaningless displays at power on can be prevented by transferring data from the controller and setting  $\overline{\text{RES}}$  high when that transfer has completed.

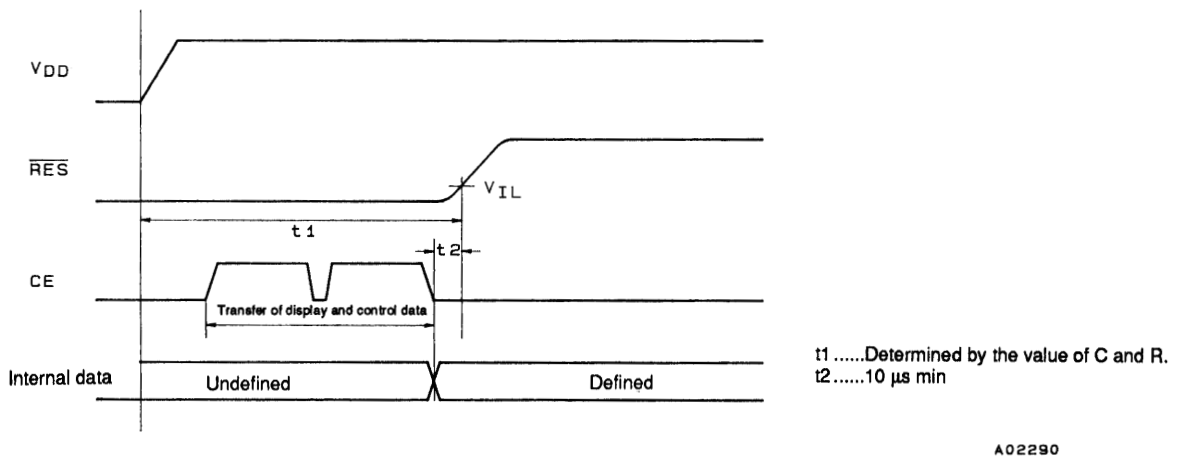
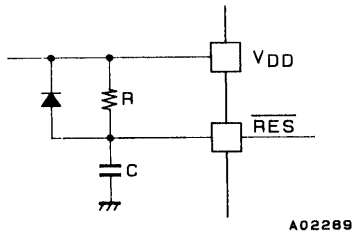
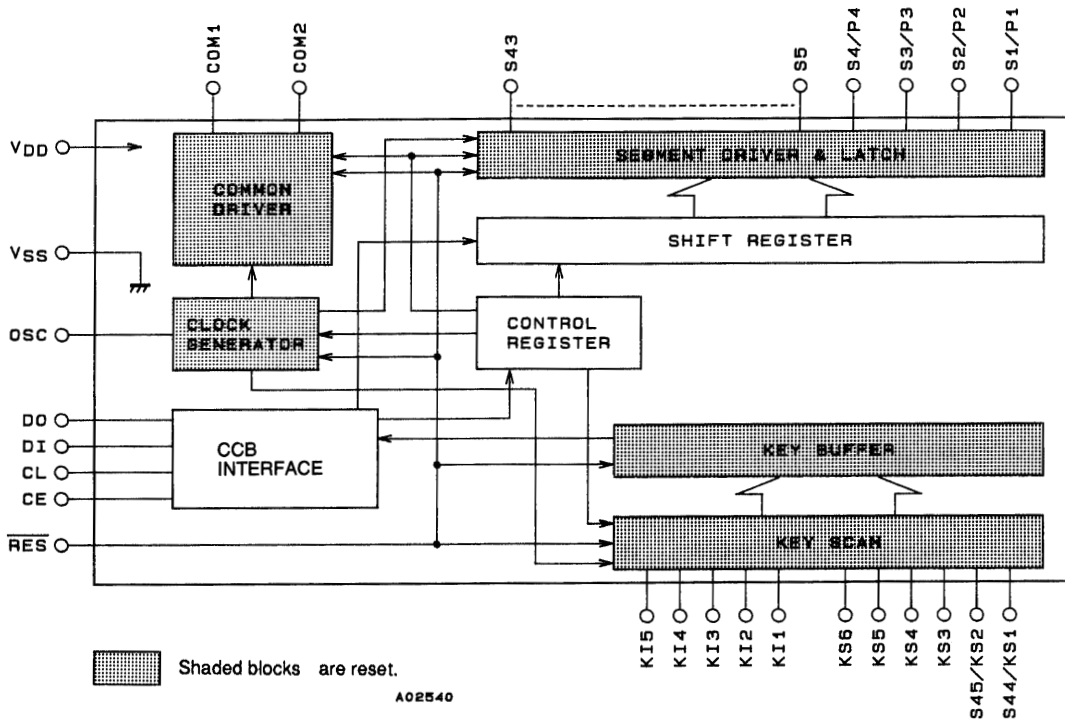

Figure 2

**Internal Block States during the Reset Period (when RES is low)**

1. **CLOCK GENERATOR**  
Reset is applied and the basic clock stops. However, the state of the OSC pin (the normal or sleep state) is determined after the control data S0 and S1 has been sent.
2. **COMMON DRIVER, SEGMENT DRIVER & LATCH**  
Reset is applied and the display is turned off. However, display data can be input to the LATCH.
3. **KEY SCAN**  
Reset is applied and at the same time as the internal states are set to their initial states, the key scan operation is disabled.
4. **KEY BUFFER**  
Reset is applied and all the key data is set to the low level.
5. **CCB INTERFACE, CONTROL REGISTER, SHIFT REGISTER**  
To allow serial data transfers, reset is not applied to these circuits.



**Output Pin States during the Reset Period (when RES is low)**

Output pin	State during reset
S1/P1 to S4/P4	L <sup>*3</sup>
S5 to S43	L
COM1, COM2	L
KS1/S44, KS2/S45	L <sup>*3</sup>
KS3 to KS5	X <sup>*4</sup>
KS6	H
DO	H <sup>*5</sup>

X: don't care

Note: 3. These output pins are forcibly set to the segment output mode and held low.

4. Immediately following power on, these output pins are undefined until the control data S0 and S1 has been sent.

5. Since this output pin is an open-drain output, a pull-up resistor of between 1 and 10 kΩ is required. This pin is held high during the reset period even if key data is read.

Sample Application Circuit

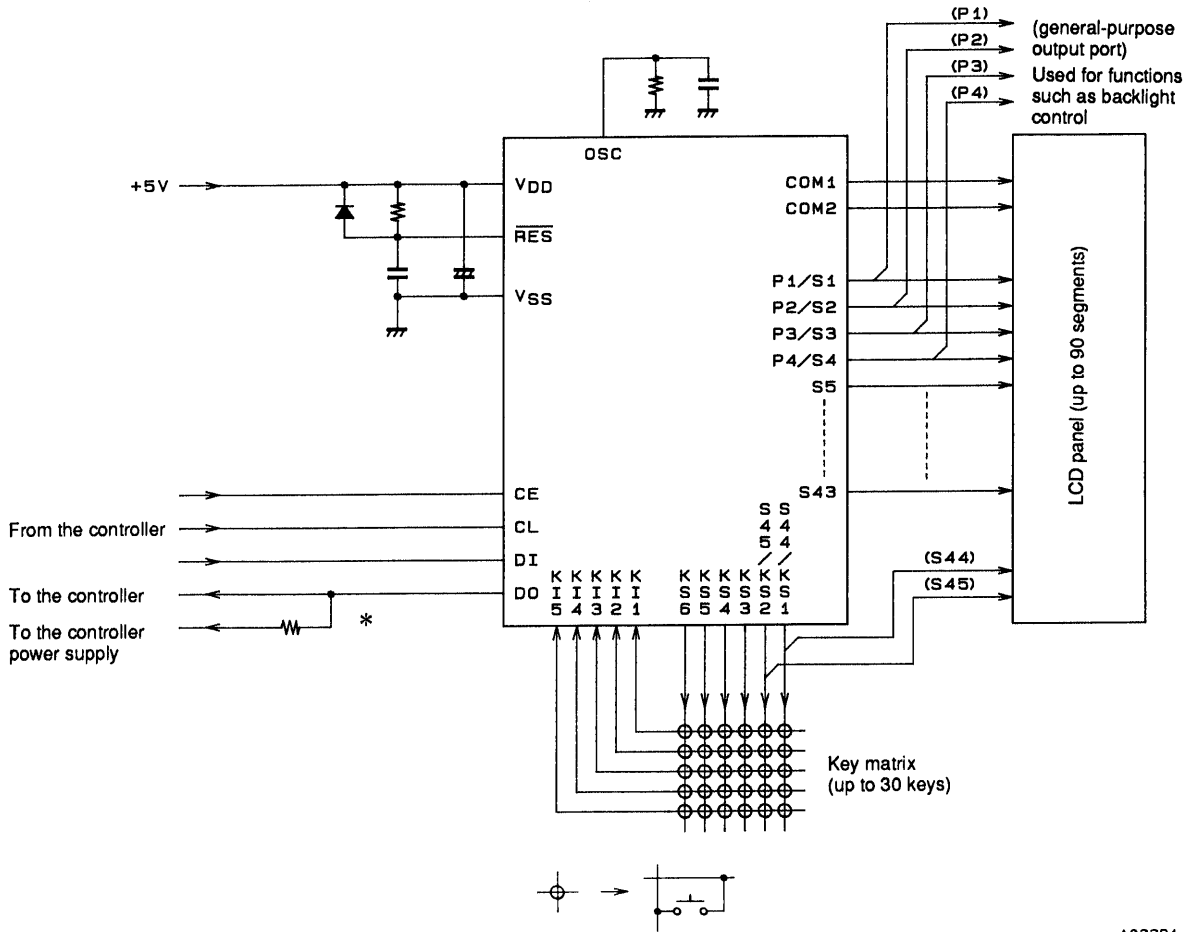

A02291

Note: \* Since DO is an open-drain output, a pull-up resistor is required. Select a value (between 1 and 10 kΩ) that is appropriate for the capacitance of the external wiring so that the waveforms are not distorted.

Notes on Controller Display Data Transfer

The LC75852 transfers the display data (D1 to D90) in two operations. To assure visual display quality, all the display data should be sent within a 30 ms or shorter period.

Notes on Controller Key Data Read Techniques

1. Controller key data reading under timer control

- Flowchart

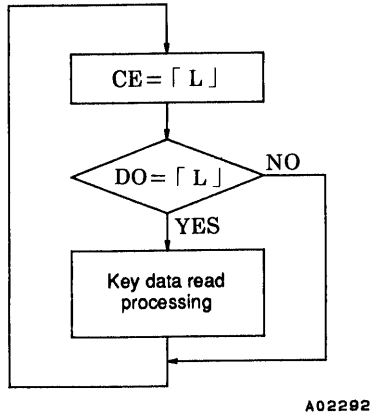

- Timing Chart

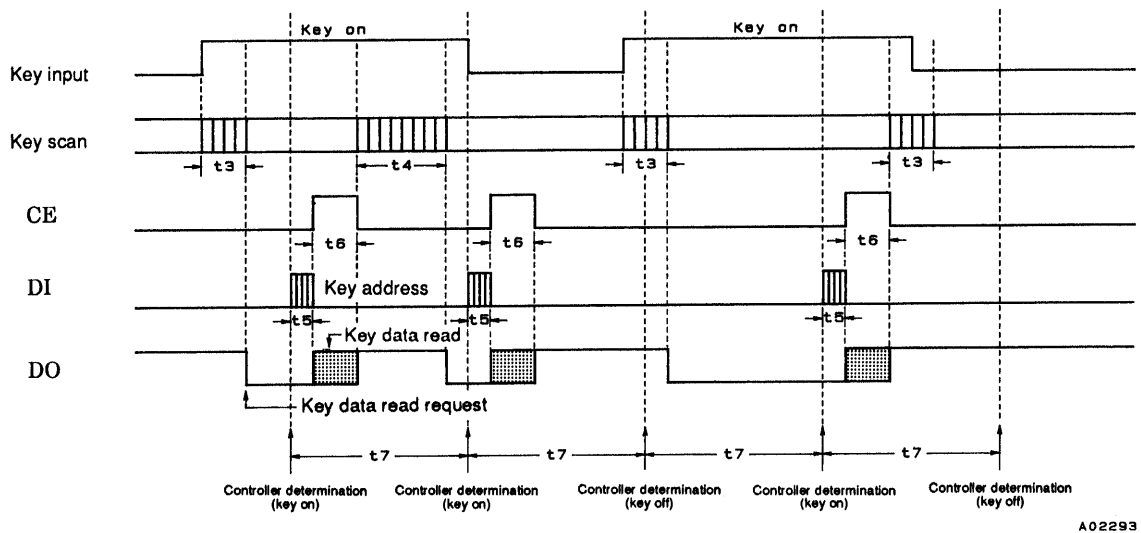

- t3 .....Key scan execution time (800T [s]) when the key scan data for two key scans agrees
- t4 .....Key scan execution time (1600T [s]) when the key scan data for two key scans does not agree and a key scan is executed again
- t5 .....Key address (43H) transfer time
- t6 .....Key data read time

$$T = \frac{1}{f_{osc}}$$

- Description

When determining key on/off and reading key data, the controller must confirm the state of DO output when CE is low for each period t7. When DO is low, the controller recognizes that a key has been pressed and reads the key data.

During this operation t7 must obey the following condition:

$$t7 > t5 + t6 + t4$$

If key data is read when DO is high, the key data (KD1 to KD30) and the sleep acknowledge data (SA) will be invalid.

2. Controller key data reading under interrupt control

- Flowchart

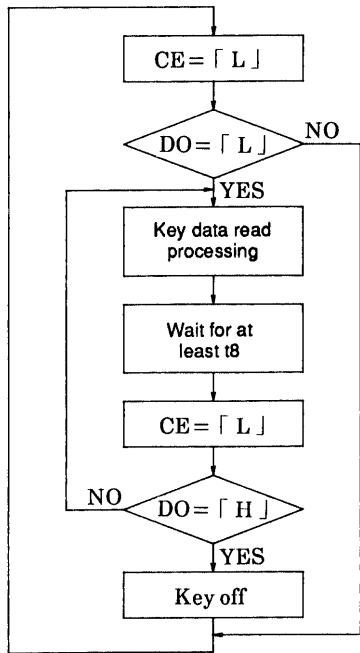

A02294

- Timing Chart

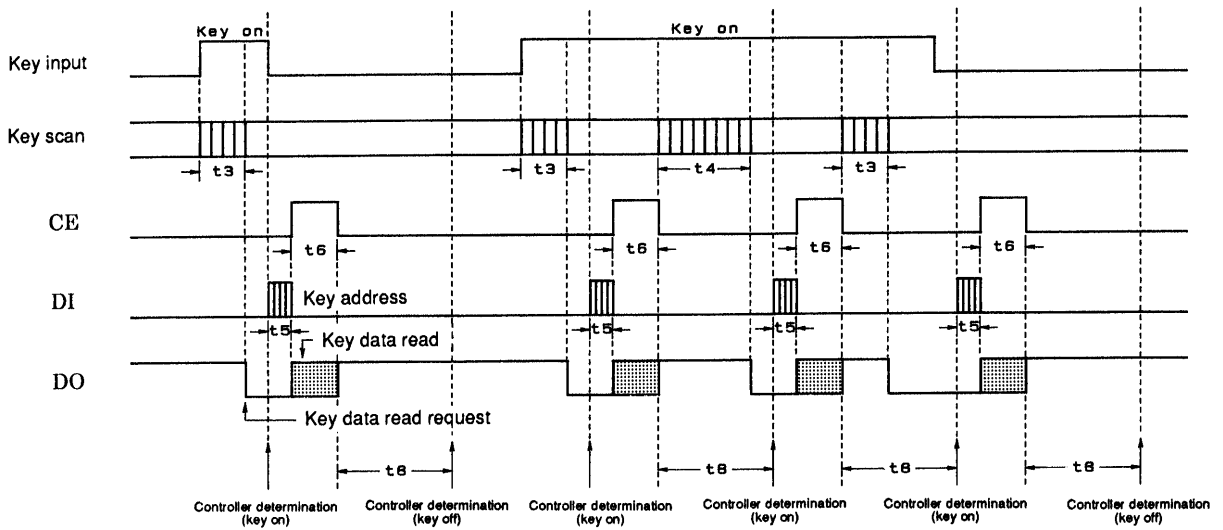

A02295

- t3 .....Key scan execution time (800T [s]) when the key scan data for two key scans agrees
- t4 .....Key scan execution time (1600T [s]) when the key scan data for two key scans does not agree and a key scan is executed again
- t5 .....Key address (43H) transfer time
- t6 .....Key data read time

$$T = \frac{1}{f_{osc}}$$

## LC75852E, LC75852W

- Description

When determining key on/off and reading key data, the controller must confirm the state of DO output when CE is low. When DO is low, the controller recognizes that a key has been pressed and reads the key data. After the time  $t_8$ , the next key on/off determination and reading key data must be confirmed by the state of DO output when CE is low. During this operation  $t_8$  must obey the following condition :

$$t_8 > t_4$$

If key data is read when DO is high, the key data (KD1 to KD30) and the sleep acknowledge data (SA) will be invalid.



# LC75852E, LC75852W

## Package Dimensions

unit : mm

[LC75852E]

PQFP64 14x14 / QIP64E

CASE 122BP

ISSUE A

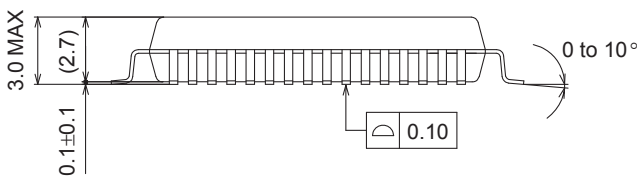
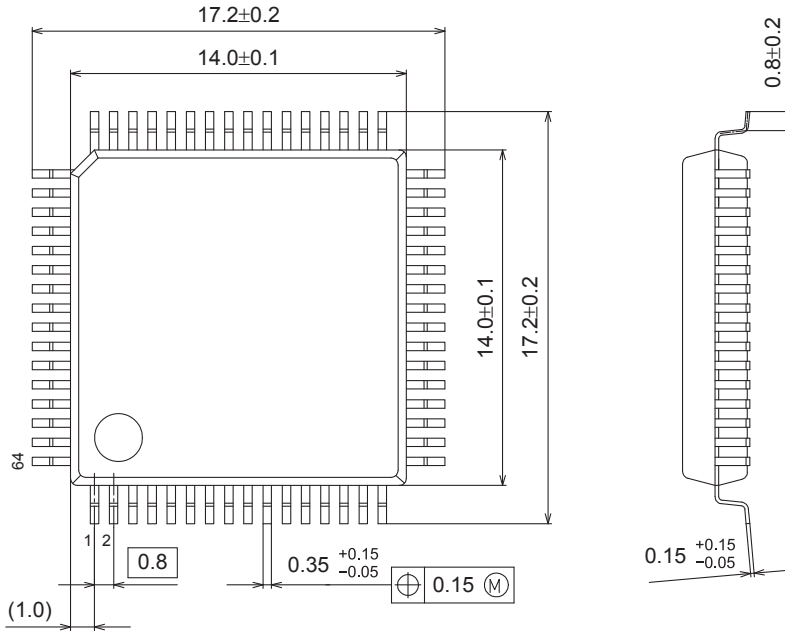

### SOLDERING FOOTPRINT\*

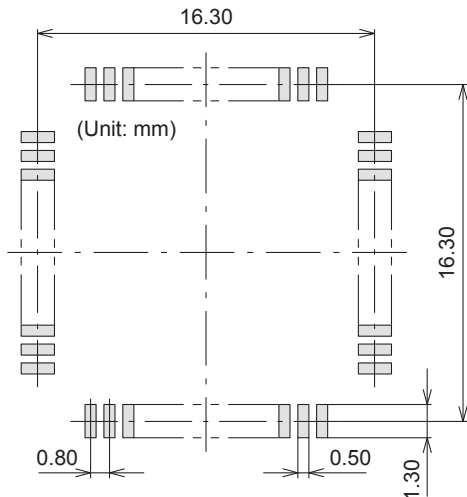

### GENERIC MARKING DIAGRAM\*

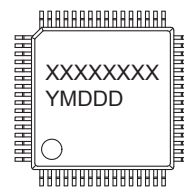

XXXXXX = Specific Device Code  
 Y = Year  
 M = Month  
 DDD = Additional Traceability Data

\*This information is generic. Please refer to device data sheet for actual part marking. Pb-Free indicator, "G" or microdot "■", may or may not be present.

NOTE: The measurements are not to guarantee but for reference only.

\*For additional information on our Pb-Free strategy and soldering details, please download the ON Semiconductor Soldering and Mounting Techniques Reference Manual, SOLDERRM/D.

# LC75852E, LC75852W

## Package Dimensions

unit : mm

[LC75852W]

SPQFP64 10x10 / SQFP64

CASE 131AK

ISSUE A

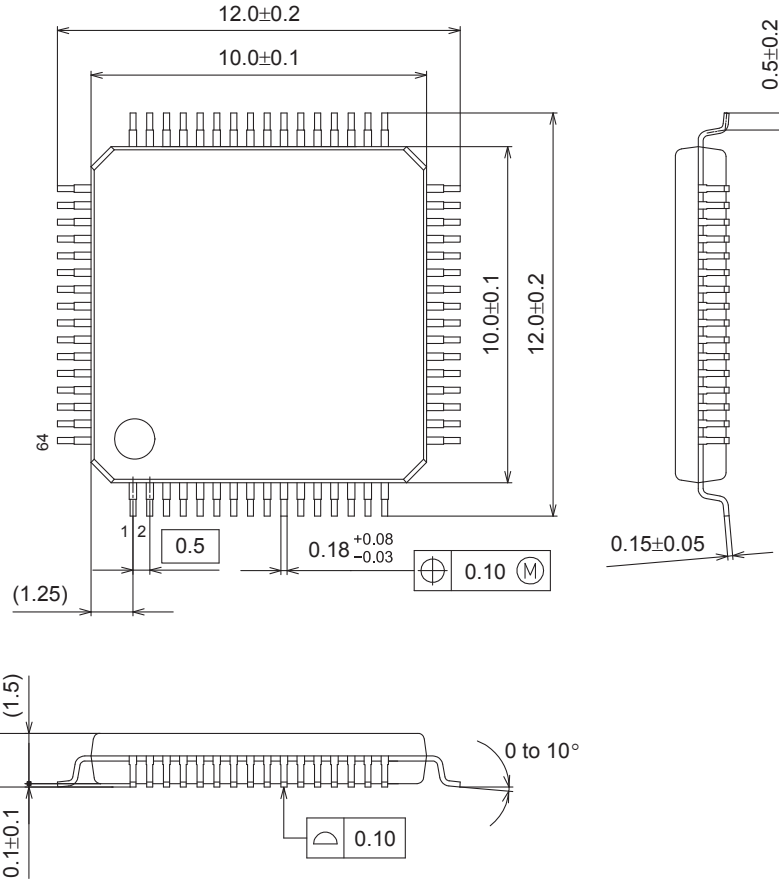

### SOLDERING FOOTPRINT\*

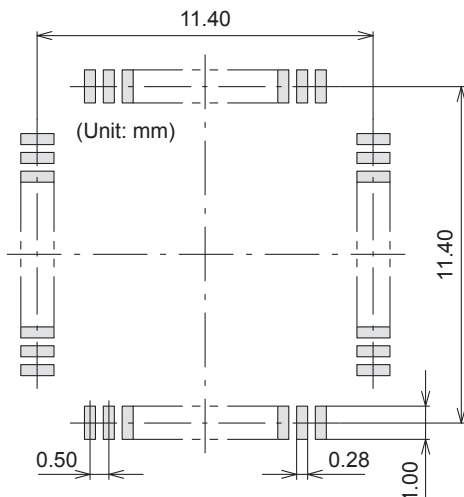

### GENERIC MARKING DIAGRAM\*

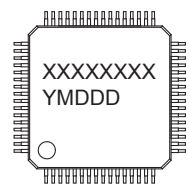
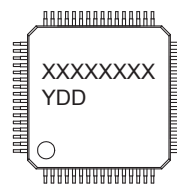

XXXXX = Specific Device Code  
Y = Year  
DD = Additional Traceability Data

XXXXX = Specific Device Code  
Y = Year  
M = Month  
DDD = Additional Traceability Data

\*This information is generic. Please refer to device data sheet for actual part marking. Pb-Free indicator, "G" or microdot "■", may or may not be present.

NOTE: The measurements are not to guarantee but for reference only.

\*For additional information on our Pb-Free strategy and soldering details, please download the ON Semiconductor Soldering and Mounting Techniques Reference Manual, SOLDERRM/D.

## LC75852E, LC75852W

### ORDERING INFORMATION

Device	Package	Shipping (Qty / Packing)
LC75852E-E	PQFP64 14x14 / QIP64E (Pb-Free)	300 / Tray Foam
LC75852EHS-E	PQFP64 14x14 / QIP64E (Pb-Free)	300 / Tray Foam
LC75852W-E	SPQFP64 10x10 / SQFP64 (Pb-Free)	800 / Tray JEDEC
LC75852W-TML-E	SPQFP64 10x10 / SQFP64 (Pb-Free)	1000 / Tape and Reel

† For information on tape and reel specifications, including part orientation and tape sizes, please refer to our Tape and Reel Packaging Specifications Brochure, BRD8011/D. [http://www.onsemi.com/pub\\_link/Collateral/BRD8011-D.PDF](http://www.onsemi.com/pub_link/Collateral/BRD8011-D.PDF)

ON Semiconductor and the ON Semiconductor logo are trademarks of Semiconductor Components Industries, LLC dba ON Semiconductor or its subsidiaries in the United States and/or other countries. ON Semiconductor owns the rights to a number of patents, trademarks, copyrights, trade secrets, and other intellectual property. A listing of ON Semiconductor's product/patent coverage may be accessed at [www.onsemi.com/site/pdf/Patent-Marking.pdf](http://www.onsemi.com/site/pdf/Patent-Marking.pdf). ON Semiconductor reserves the right to make changes without further notice to any products herein. ON Semiconductor makes no warranty, representation or guarantee regarding the suitability of its products for any particular purpose, nor does ON Semiconductor assume any liability arising out of the application or use of any product or circuit, and specifically disclaims any and all liability, including without limitation special, consequential or incidental damages. Buyer is responsible for its products and applications using ON Semiconductor products, including compliance with all laws, regulations and safety requirements or standards, regardless of any support or applications information provided by ON Semiconductor. "Typical" parameters which may be provided in ON Semiconductor data sheets and/or specifications can and do vary in different applications and actual performance may vary over time. All operating parameters, including "Typicals" must be validated for each customer application by customer's technical experts. ON Semiconductor does not convey any license under its patent rights nor the rights of others. ON Semiconductor products are not designed, intended, or authorized for use as a critical component in life support systems or any FDA Class 3 medical devices or medical devices with a same or similar classification in a foreign jurisdiction or any devices intended for implantation in the human body. Should Buyer purchase or use ON Semiconductor products for any such unintended or unauthorized application, Buyer shall indemnify and hold ON Semiconductor and its officers, employees, subsidiaries, affiliates, and distributors harmless against all claims, costs, damages, and expenses, and reasonable attorney fees arising out of, directly or indirectly, any claim of personal injury or death associated with such unintended or unauthorized use, even if such claim alleges that ON Semiconductor was negligent regarding the design or manufacture of the part. ON Semiconductor is an Equal Opportunity/Affirmative Action Employer. This literature is subject to all applicable copyright laws and is not for resale in any manner.

## X-ON Electronics

Largest Supplier of Electrical and Electronic Components

*Click to view similar products for [LCD Drivers](#) category:*

*Click to view products by [ON Semiconductor](#) manufacturer:*

Other Similar products are found below :

[LC75836WH-E](#) [CD4056BE](#) [LC75829PW-H](#) [LC75852W-E](#) [LC79430KNE-E](#) [LC79431KNE-E](#) [FAN7317BMX](#) [LC75839PW-H](#) [LC75884W-E](#) [LC75814VS-TLM-E](#) [MAX25520ATEC/V+](#) [MAX25520ATEB/VY+](#) [BU9795AFV-E2](#) [PCF8566T/1.118](#) [TPS65132A0YFFR](#) [BU9795AKV-E2](#) [34801000](#) [BU97510CKV-ME2](#) [BU97520AKV-ME2](#) [ICL7136CM44Z](#) [BL55070](#) [BL55066](#) [MAX1605ETT+T](#) [MAX16928BGUP/V+](#) [ICL7129ACPL+](#) [MAX131CMHD](#) [MAX138CMH+D](#) [MAX1491CAI+](#) [MAX1518BETJ+](#) [MAX1606EUA+](#) [MAX138CQH+TD](#) [MAX25520ATEB/V+](#) [MAX16929AGUI/V+](#) [MAX16929CGUI/V+](#) [MAX16929DGUI/V+](#) [MAX8570ELT+T](#) [MAX8570EUT+T](#) [MAX8571EUT+T](#) [MAX8575EUT+T](#) [MAX8795AGCJ/V+](#) [MAX138CPL+](#) [AY0438-I/L](#) [AY0438/L](#) [HV66PG-G](#) [HV881K7-G](#) [TC7106CKW](#) [TC7106CPL](#) [TC7116CPL](#) [TC7126CLW](#) [TC7126CPL](#)