



LC87F2G08A

CMOS IC 8K-byte FROM and 256-byte RAM integrated 8-bit 1-chip Microcontroller

ON Semiconductor®

<http://onsemi.com>

Overview

The LC87F2G08A is an 8-bit microcomputer that, integrates on a single chip a number of hardware features such as 8K-byte flash ROM, 256-byte RAM, an On-chip-debugger, a 16-bit timers/counters, two 8-bit timers, a base timer serving as a time-of-day clock, a high-speed clock counter, a synchronous SIO interface, an asynchronous/synchronous SIO interface, a UART interface, a 12-bit/8-bit 8-channel AD converter, a system clock frequency divider, an internal reset and an interrupt feature.

Features

■Flash ROM

- 8192 × 8 bits
- Capable of On-board programming with wide range (2.2 to 5.5V) of voltage source.
- Block-erasable in 128 byte units
- Writable in 2-byte units

■RAM

- 256 × 9 bits

■Package Form

- MFP24SJ (300mil): Lead-/Halogen-free type
- SSOP24 (225mil): Lead-free type
- VCT24 (3.5×3.5): Lead-/Halogen-free type (build-to-order)
- MFP24S (300mil): Lead-free type (discontinued)

Package Dimensions

unit : mm (typ)
3419

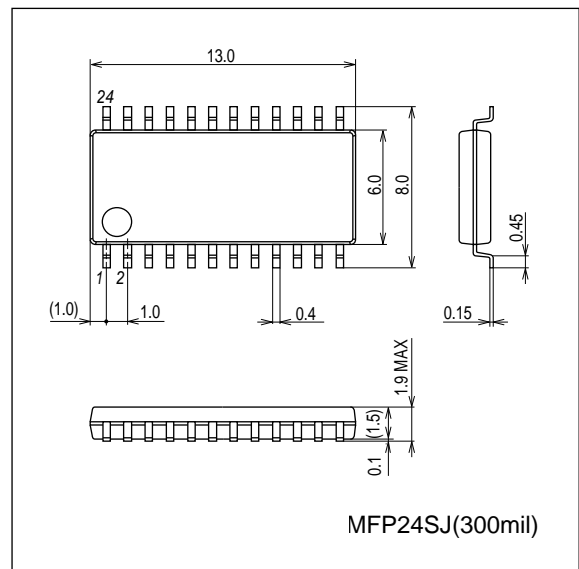

* This product is licensed from Silicon Storage Technology, Inc. (USA).

LC87F2G08A

Package Dimensions

unit : mm (typ)
3287

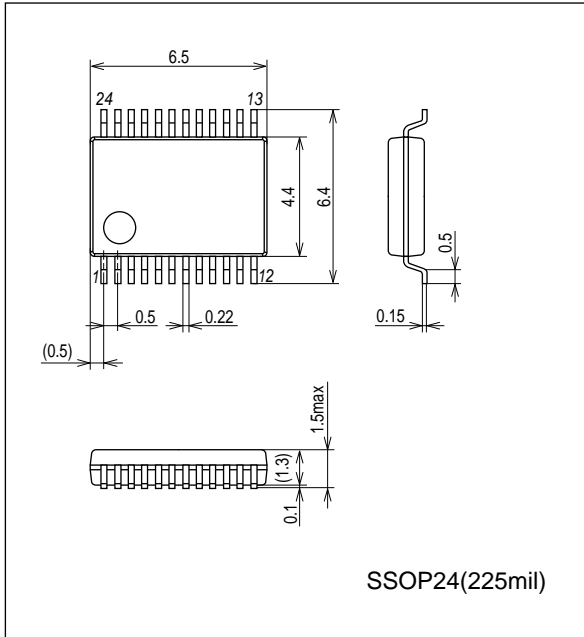

Package Dimensions

unit : mm (typ)
3322A

(Build-to-order)

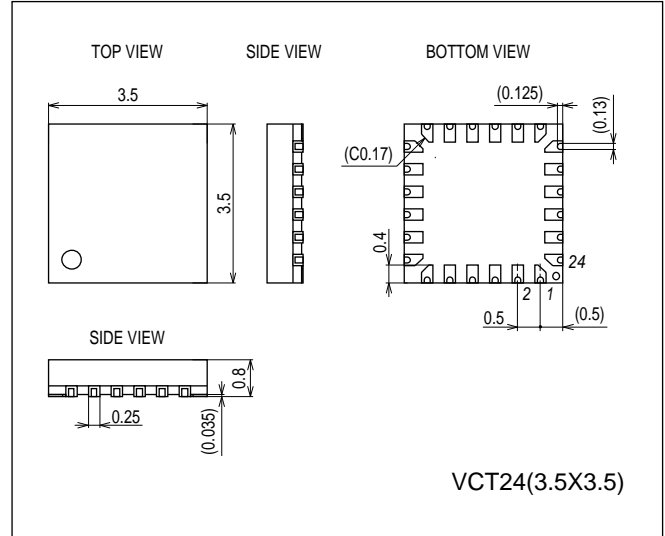

Package Dimensions

unit : mm (typ)
3112B

(Discontinued)

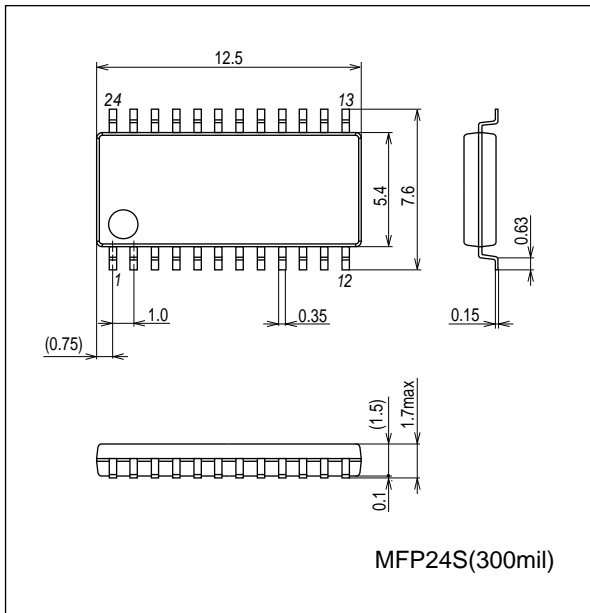

■ Minimum Bus Cycle

- 83.3ns (12MHz at $V_{DD}=2.7V$ to 5.5V)
- 100ns (10MHz at $V_{DD}=2.2V$ to 5.5V)
- 250ns (4MHz at $V_{DD}=1.8V$ to 5.5V)

Note: The bus cycle time here refers to the ROM read speed.

■ Minimum Instruction Cycle Time

- 250ns (12MHz at $V_{DD}=2.7V$ to 5.5V)
- 300ns (10MHz at $V_{DD}=2.2V$ to 5.5V)
- 750ns (4MHz at $V_{DD}=1.8V$ to 5.5V)

LC87F2G08A

■ Ports

- Normal withstand voltage I/O ports
 - Ports I/O direction can be designated in 1-bit units 11 (P1n, P20, P21, P70)
 - Ports I/O direction can be designated in 4-bit units 8 (P0n)
- Dedicated oscillator ports/input ports 2 (CF1/XT1, CF2/XT2)
- Reset pin 1 ($\overline{\text{RES}}$)
- Power pins 2 (V_{SS1} , V_{DD1})

■ Timers

- Timer 0: 16-bit timer/counter with a capture register.
 - Mode 0: 8-bit timer with an 8-bit programmable prescaler (with an 8-bit capture register) \times 2 channels
 - Mode 1: 8-bit timer with an 8-bit programmable prescaler (with an 8-bit capture register) + 8-bit counter (with an 8-bit capture register)
 - Mode 2: 16-bit timer with an 8-bit programmable prescaler (with a 16-bit capture register)
 - Mode 3: 16-bit counter (with a 16-bit capture register)
- Timer 1: 16-bit timer/counter that supports PWM/toggle outputs
 - Mode 0: 8-bit timer with an 8-bit prescaler (with toggle outputs) + 8-bit timer/counter with an 8-bit prescaler (with toggle outputs)
 - Mode 1: 8-bit PWM with an 8-bit prescaler \times 2 channels
 - Mode 2: 16-bit timer/counter with an 8-bit prescaler (with toggle outputs) (toggle outputs also possible from the lower-order 8 bits)
 - Mode 3: 16-bit timer with an 8-bit prescaler (with toggle outputs) (The lower-order 8 bits can be used as PWM)
- Timer 6: 8-bit timer with a 6-bit prescaler (with toggle outputs)
- Timer 7: 8-bit timer with a 6-bit prescaler (with toggle outputs)
- Base timer
 - 1) The clock is selectable from the subclock (32.768kHz crystal oscillation), system clock, and timer 0 prescaler output.
 - 2) Interrupts are programmable in 5 different time schemes

■ High-Speed Clock Counter

- Can count clocks with a maximum clock rate of 20MHz (at a main clock of 10MHz).
- Can generate output real time.

■ SIO

- SIO0: 8-bit Synchronous serial interface
 - 1) LSB first/MSB first mode selectable
 - 2) Built-in 8-bit baudrate generator (maximum transfer clock cycle=4/3tCYC)
- SIO1: 8-bit asynchronous/synchronous serial interface
 - Mode 0: Synchronous 8-bit serial I/O (2- or 3-wire configuration, 2 to 512 tCYC transfer clocks)
 - Mode 1: Asynchronous serial I/O (half-duplex, 8 data bits, 1 stop bit, 8 to 2048 tCYC baudrates)
 - Mode 2: Bus mode 1 (start bit, 8 data bits, 2 to 512 tCYC transfer clocks)
 - Mode 3: Bus mode 2 (start detect, 8 data bits, stop detect)

■ UART

- Full Duplex
- 7/8/9 bit data bits selectable
- 1 stop bit (2 bits in continuous data transmission)
- Built-in baudrate generator

■ AD Converter: 12 bits/8 bits \times 8 channels

- 12 bits/8 bits AD converter resolution selectable

■ Remote Control Receiver Circuit (sharing pins with P15, SCK1, INT3, and T0IN)

- Noise rejection function (noise filter time constant selectable from 1 tCYC, 32 tCYC, and 128 tCYC)

LC87F2G08A

■ Clock Output Function

- Can generate clock outputs with a frequency of 1/1, 1/2, 1/4, 1/8, 1/16, 1/32, 1/64 of the source clock selected as the system clock.
- Can generate the source clock for the subclock

■ Watchdog Timer

- External RC watchdog timer
- Interrupt and reset signals selectable

■ Interrupts

- 18 sources, 10 vector addresses
 - 1) Provides three levels (low (L), high (H), and highest (X)) of multiplex interrupt control. Any interrupt requests of the level equal to or lower than the current interrupt are not accepted.
 - 2) When interrupt requests to two or more vector addresses occur at the same time, the interrupt of the highest level takes precedence over the other interrupts. For interrupts of the same level, the interrupt into the smallest vector address takes precedence.

No.	Vector Address	Level	Interrupt Source
1	00003H	X or L	INT0
2	0000BH	X or L	INT1
3	00013H	H or L	INT2/T0L/INT4
4	0001BH	H or L	INT3/base timer
5	00023H	H or L	T0H
6	0002BH	H or L	T1L/T1H
7	00033H	H or L	SIO0/UART1 receive
8	0003BH	H or L	SIO1/UART1 transmit
9	00043H	H or L	ADC/T6/T7
10	0004BH	H or L	Port 0

- Priority levels $X > H > L$
- Of interrupts of the same level, the one with the smallest vector address takes precedence.

■ Subroutine Stack Levels: 128levels (The stack is allocated in RAM.)

■ High-speed Multiplication/Division Instructions

- 16 bits \times 8 bits (5 tCYC execution time)
- 24 bits \times 16 bits (12 tCYC execution time)
- 16 bits \div 8 bits (8 tCYC execution time)
- 24 bits \div 16 bits (12 tCYC execution time)

■ Oscillation Circuits

- Internal oscillation circuits
 - Low-speed RC oscillation circuit : For system clock (100kHz)
 - Medium-speed RC oscillation circuit : For system clock (1MHz)
 - Multifrequency RC oscillation circuit : For system clock (8MHz)
- External oscillation circuits
 - Hi-speed CF oscillation circuit: For system clock, with internal Rf
 - Low speed crystal oscillation circuit: For low-speed system clock, with internal Rf
 - 1) The CF and crystal oscillation circuits share the same pins. The active circuit is selected under program control.
 - 2) Both the CF and crystal oscillator circuits stop operation on a system reset. When the reset is released, only the CF oscillation circuit resumes operation.

■ System Clock Divider Function

- Can run on low current.
- The minimum instruction cycle selectable from 300ns, 600ns, 1.2 μ s, 2.4 μ s, 4.8 μ s, 9.6 μ s, 19.2 μ s, 38.4 μ s, and 76.8 μ s (at a main clock rate of 10MHz).

■ Internal Reset Function

- Power-on reset (POR) function
 - 1) POR reset is generated only at power-on time.
 - 2) The POR release level can be selected from 8 levels (1.67V, 1.97V, 2.07V, 2.37V, 2.57V, 2.87V, 3.86V, and 4.35V) through option configuration.
- Low-voltage detection reset (LVD) function
 - 1) LVD and POR functions are combined to generate resets when power is turned on and when power voltage falls below a certain level.
 - 2) The use/disuse of the LVD function and the low voltage threshold level (7 levels: 1.91V, 2.01V, 2.31V, 2.51V, 2.81V, 3.79V, 4.28V).

■ Standby Function

- HALT mode: Halts instruction execution while allowing the peripheral circuits to continue operation.
 - 1) Oscillation is not halted automatically.
 - 2) There are three ways of resetting the HALT mode.
 - (1) Setting the reset pin to the low level
 - (2) System resetting by watchdog timer or low-voltage detection
 - (3) Occurrence of an interrupt
 - HOLD mode: Suspends instruction execution and the operation of the peripheral circuits.
 - 1) The CF, RC, and crystal oscillators automatically stop operation.
 - 2) There are four ways of resetting the HOLD mode.
 - (1) Setting the reset pin to the lower level.
 - (2) System resetting by watchdog timer or low-voltage detection
 - (3) Having an interrupt source established at either INT0, INT1, INT2, INT4
 - * INT0 and INT1 HOLD mode reset is available only when level detection is set.
 - (4) Having an interrupt source established at port 0.
 - X'tal HOLD mode: Suspends instruction execution and the operation of the peripheral circuits except the base timer.
 - 1) The CF and RC oscillators automatically stop operation.
 - 2) The state of crystal oscillation established when the X'tal HOLD mode is entered is retained.
 - 3) There are five ways of resetting the X'tal HOLD mode.
 - (1) Setting the reset pin to the low level.
 - (2) System resetting by watchdog timer or low-voltage detection.
 - (3) Having an interrupt source established at either INT0, INT1, INT2, INT4
 - * INT0 and INT1 HOLD mode reset is available only when level detection is set.
 - (4) Having an interrupt source established at port 0.
 - (5) Having an interrupt source established in the base timer circuit.
- Note: Available only when X'tal oscillation is selected.

■ Onchip Debugger

- Supports software debugging with the IC mounted on the target board.
- Two channels of on-chip debugger pins are available to be compatible with small pin count devices.
DBGP0 (P0), DBGP1 (P1)

■ Data Security Function (flash versions only)

- Protects the program data stored in flash memory from unauthorized read or copy.
Note: This data security function does not necessarily provide absolute data security.

■ Development Tools

- On-chip debugger: (1) TCB87 type B + LC87D2G08A
(2) TCB87 TypeB + LC87F2G08A
(3) TCB87 TypeC (3 wire version) + LC87D2G08A
(4) TCB87 TypeC (3 wire version) + LC87F2G08A

Note: LC87F2G08A has an On-chip debugger but its function is limited.

LC87F2G08A

■Flash ROM Programming Boards

Package	Programming boards
MFP24S(300mil)	W87F2GM
MFP24SJ(300mil)	W87F2GMJ
SSOP24(225mil)	W87F2GS
VCT24(3.5×3.5)	(build-to-order)

■Flash ROM Programmer

Maker		Model	Supported version	Device
Flash Support Group, Inc. (FSG)	Single Programmer	AF9708 AF9709/AF9709B/AF9709C (Including Ando Electric Co., Ltd. models)	Rev 02.72 or later	LC87F2H08A
	Gang Programmer	AF9723/AF9723B(Main body) (Including Ando Electric Co., Ltd. models)	-	-
		AF9833(Unit) (Including Ando Electric Co., Ltd. models)	-	-
Flash Support Group, Inc. (FSG) + Our company (Note 1)	In-circuit Programmer	AF9101/AF9103(Main body) (FSG models) SIB87(Inter Face Driver) (Our company model)	(Note 2)	LC87F2G08A
Our company	Single/Gang Programmer	SKK/SKK Type B (SanyoFWS)	Application Version 1.04 or later	LC87F2G08A
	In-circuit/Gang Programmer	SKK-DBG Type B (SanyoFWS)	Chip Data Version 2.10 or later	

For information about AF-Series:

Flash Support Group, Inc.

TEL: +81-53-459-1050

E-mail: sales@j-fsg.co.jp

Note1: On-board-programmer from FSG (AF9101/AF9103) and serial interface driver from Our company (SIB87) together can give a PC-less, standalone on-board-programming capabilities.

Note2: It needs a special programming devices and applications depending on the use of programming environment. Please ask FSG or Our company for the information.

LC87F2G08A

Pin Assignment

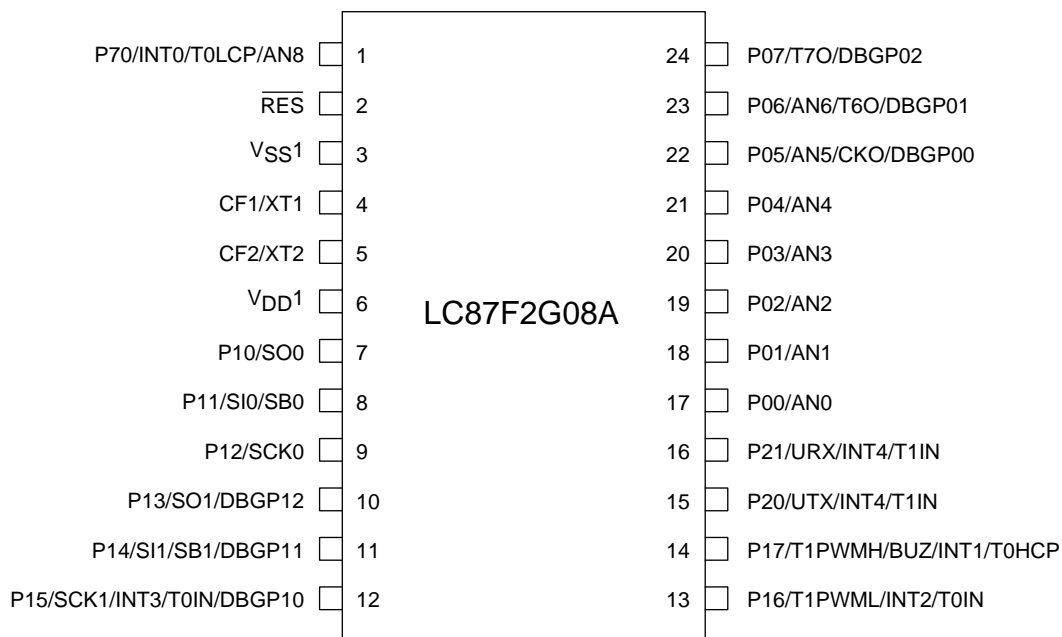

Top view

MFP24S (300mil) “Lead-free Type”
MFP24SJ (300mil) “Lead-/Halogen-free Type”
SSOP24 (225mil) “Lead-free Type”

MFP24S/ MFP24SJ/ SSOP24	NAME
1	P70/INT0/T0LCP/AN8
2	RES
3	V _{SS1}
4	CF1/XT1
5	CF2/XT2
6	V _{DD1}
7	P10/SO0
8	P11/SI0/SB0
9	P12/SCK0
10	P13/SO1/DBGP12
11	P14/SI1/SB1/DBGP11
12	P15/SCK1/INT3/T0IN/DBGP10

MFP24S/ MFP24SJ/ SSOP24	NAME
13	P16/T1PWML/INT2/T0IN
14	P17/T1PWMH/BUZ/INT1/T0HCP
15	P20/UTX/INT4/T1IN
16	P21/URX/INT4/T1IN
17	P00/AN0
18	P01/AN1
19	P02/AN2
20	P03/AN3
21	P04/AN4
22	P05/AN5/CKO/DBGP00
23	P06/AN6/T6O/DBGP01
24	P07/T7O/DBGP02

LC87F2G08A

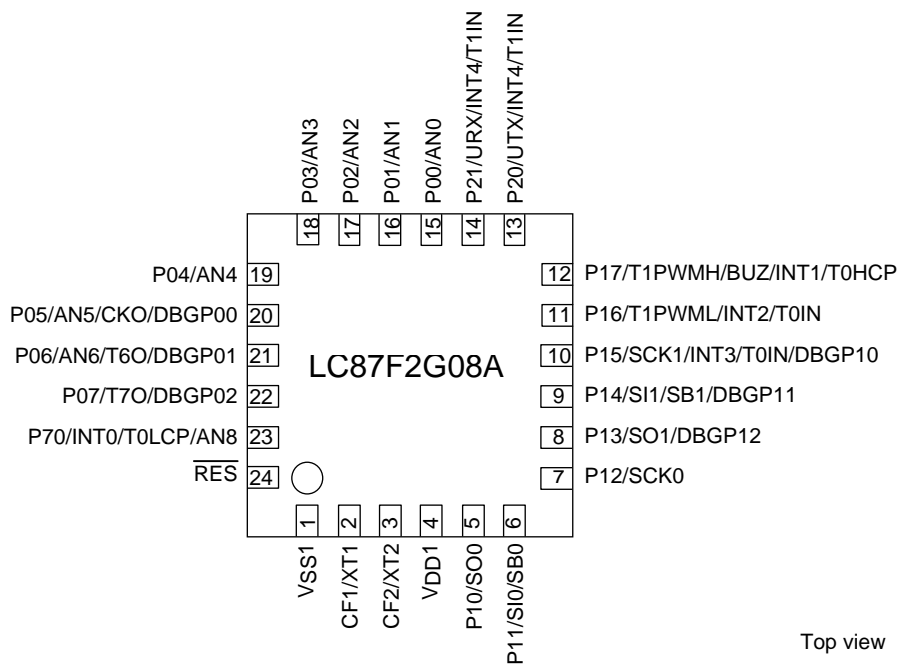

VCT24(3.5×3.5) “Lead-/Halogen-free Type” (build-to-order)

VCT24	NAME
1	VSS1
2	CF1/XT1
3	CF2/XT2
4	VDD1
5	P10/SO0
6	P11/SI0/SB0
7	P12/SCK0
8	P13/SO1/DBGP12
9	P14/SI1/SB1/DBGP11
10	P15/SCK1/INT3/T0IN/DBGP10
11	P16/T1PWML/INT2/T0IN
12	P17/T1PWMH/BUZ/INT1/T0HCP

VCT24	NAME
13	P20/UTX/INT4/T1IN
14	P21/URX/INT4/T1IN
15	P00/AN0
16	P01/AN1
17	P02/AN2
18	P03/AN3
19	P04/AN4
20	P05/AN5/CKO/DBGP00
21	P06/AN6/T6O/DBGP01
22	P07/T7O/DBGP02
23	P70/INT0/T0LCP/AN8
24	RES

System Block Diagram

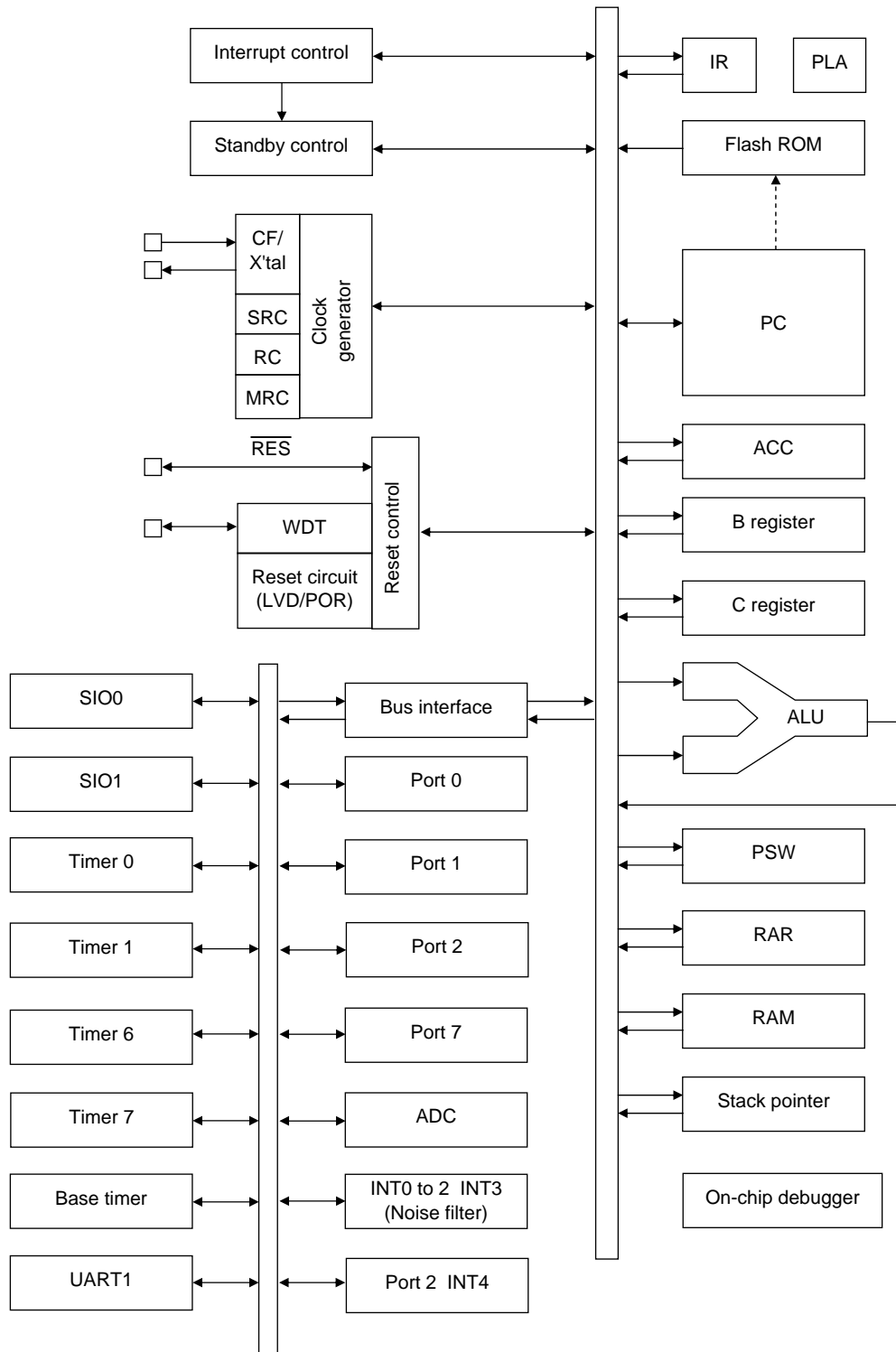

LC87F2G08A

Pin Description

Pin Name	I/O	Description	Option																								
V _{SS} 1	-	- Power supply pin	No																								
V _{DD} 1	-	+ Power supply pin	No																								
Port 0 P00 to P07	I/O	<ul style="list-style-type: none"> • 8-bit I/O port • I/O specifiable in 4-bit units • Pull-up resistors can be turned on and off in 4-bit units. • HOLD reset input • Port 0 interrupt input • Pin functions <ul style="list-style-type: none"> P05: System clock output P06: Timer 6 toggle output P07: Timer 7 toggle output P00(AN0) to P06(AN6): AD converter input P05(DBGP00) to P07(DBGP02): On-chip debugger 0 port 	Yes																								
Port 1 P10 to P17	I/O	<ul style="list-style-type: none"> • 8-bit I/O port • I/O specifiable in 1-bit units • Pull-up resistors can be turned on and off in 1-bit units. • Pin functions <ul style="list-style-type: none"> P10: SIO0 data output P11: SIO0 data input/bus I/O P12: SIO0 clock I/O P13: SIO1 data output P14: SIO1 data input / bus I/O P15: SIO1 clock I/O / INT3 input (with noise filter) / timer 0 event input / timer 0H capture input P16: Timer 1PWML output / INT2 input/HOLD reset input/timer 0 event input / timer 0L capture input P17: Timer 1PWML output / beeper output / INT1 input / HOLD reset input / timer 0H capture input P15(DBGP10) to P13(DBGP12): On-chip-debugger 1 port <p>Interrupt acknowledge type</p> <table border="1" style="width: 100%; border-collapse: collapse; margin-top: 5px;"> <thead> <tr> <th style="width: 15%;"></th> <th style="width: 15%;">Rising</th> <th style="width: 15%;">Falling</th> <th style="width: 15%;">Rising & Falling</th> <th style="width: 15%;">H level</th> <th style="width: 15%;">L level</th> </tr> </thead> <tbody> <tr> <td>INT1</td> <td style="text-align: center;">enable</td> <td style="text-align: center;">enable</td> <td style="text-align: center;">disable</td> <td style="text-align: center;">enable</td> <td style="text-align: center;">enable</td> </tr> <tr> <td>INT2</td> <td style="text-align: center;">enable</td> <td style="text-align: center;">enable</td> <td style="text-align: center;">enable</td> <td style="text-align: center;">disable</td> <td style="text-align: center;">disable</td> </tr> <tr> <td>INT3</td> <td style="text-align: center;">enable</td> <td style="text-align: center;">enable</td> <td style="text-align: center;">enable</td> <td style="text-align: center;">disable</td> <td style="text-align: center;">disable</td> </tr> </tbody> </table>		Rising	Falling	Rising & Falling	H level	L level	INT1	enable	enable	disable	enable	enable	INT2	enable	enable	enable	disable	disable	INT3	enable	enable	enable	disable	disable	Yes
	Rising	Falling	Rising & Falling	H level	L level																						
INT1	enable	enable	disable	enable	enable																						
INT2	enable	enable	enable	disable	disable																						
INT3	enable	enable	enable	disable	disable																						
Port 2 P20 to P21	I/O	<ul style="list-style-type: none"> • 2-bit I/O port • I/O specifiable in 1-bit units • Pull-up resistors can be turned on and off in 1-bit units. • Pin functions <ul style="list-style-type: none"> P20: UART transmit P21: UART receive P20 to P21: INT4 input / HOLD reset input / timer 1 event input / timer 0L capture input / timer 0H capture input <p>Interrupt acknowledge types</p> <table border="1" style="width: 100%; border-collapse: collapse; margin-top: 5px;"> <thead> <tr> <th style="width: 15%;"></th> <th style="width: 15%;">Rising</th> <th style="width: 15%;">Falling</th> <th style="width: 15%;">Rising & Falling</th> <th style="width: 15%;">H level</th> <th style="width: 15%;">L level</th> </tr> </thead> <tbody> <tr> <td>INT4</td> <td style="text-align: center;">enable</td> <td style="text-align: center;">enable</td> <td style="text-align: center;">enable</td> <td style="text-align: center;">disable</td> <td style="text-align: center;">disable</td> </tr> </tbody> </table>		Rising	Falling	Rising & Falling	H level	L level	INT4	enable	enable	enable	disable	disable	Yes												
	Rising	Falling	Rising & Falling	H level	L level																						
INT4	enable	enable	enable	disable	disable																						

Continued on next page.

LC87F2G08A

Continued from preceding page.

Pin Name	I/O	Description	Option												
Port 7	I/O	<ul style="list-style-type: none"> • 1-bit I/O port • I/O specifiable in 1-bit units • Pull-up resistors can be turned on and off in 1-bit units. • Pin functions P70: INT0 input / HOLD reset input / timer 0L capture input / watchdog timer output P70(AN8): AD converter input Interrupt acknowledge types <table border="1" style="margin-left: 20px; width: 100%;"> <thead> <tr> <th></th> <th>Rising</th> <th>Falling</th> <th>Rising & Falling</th> <th>H level</th> <th>L level</th> </tr> </thead> <tbody> <tr> <td>INT0</td> <td>enable</td> <td>enable</td> <td>disable</td> <td>enable</td> <td>enable</td> </tr> </tbody> </table>		Rising	Falling	Rising & Falling	H level	L level	INT0	enable	enable	disable	enable	enable	No
			Rising	Falling	Rising & Falling	H level	L level								
INT0	enable	enable	disable	enable	enable										
P70															
RES	I/O	External reset input / internal reset output	No												
CF1/XT1	I	<ul style="list-style-type: none"> • Ceramic resonator or 32.768kHz crystal oscillator input pin • Pin function General-purpose input port	No												
CF2/XT2	I/O	<ul style="list-style-type: none"> • Ceramic resonator or 32.768kHz crystal oscillator output pin • Pin function General-purpose input port	No												

Port Output Types

The table below lists the types of port outputs and the presence/absence of a pull-up resistor.

Data can be read into any input port even if it is in the output mode.

Port Name	Option selected in units of	Option type	Output type	Pull-up resistor
P00 to P07	1 bit	1	CMOS	Programmable (Note 1)
		2	Nch-open drain	No
P10 to P17	1 bit	1	CMOS	Programmable
		2	Nch-open drain	Programmable
P20 to P21	1 bit	1	CMOS	Programmable
		2	Nch-open drain	Programmable
P70	-	No	Nch-open drain	Programmable

Note 1: The control of the presence or absence of the programmable pull-up resistors for port 0 and the switching between low-and high-impedance pull-up connection is exercised in nibble (4-bit) units (P00 to 03 or P04 to 07).

LC87F2G08A

User Option Table

Option Name	Option to be Applied on	Flash-ROM Version	Option Selected in Units of	Option Selection
Port output type	P00 to P07	○	1 bit	CMOS
				Nch-open drain
	P10 to P17	○	1 bit	CMOS
				Nch-open drain
	P20 to P21	○	1 bit	CMOS
				Nch-open drain
Program start address	-	○	-	00000h
				01E00h
Low-voltage detection reset function	Detect function	○	-	Enable:Use
				Disable:Not Used
	Detect level	○	-	7-level
Power-on reset function	Power-On reset level	○	-	8-level

Recommended Unused Pin Connections

Port Name	Recommended Unused Pin Connections	
	Board	Software
P00 to P07	Open	Output low
P10 to P17	Open	Output low
P20 to P21	Open	Output low
P70	Open	Output low
CF1/XT1	Pulled low with a 100kΩ resistor or less	General-purpose input port
CF2/XT2	Pulled low with a 100kΩ resistor or less	General-purpose input port

Notes on CF1/XT1 and CF2/XT2 pins

- When using as general-purpose input ports

Since the CF1/XT1 and CF2/XT2 pins are configured as CF oscillator pins at system reset time, it is necessary to add a current limiting resistor of 1kΩ or greater to the CF2/XT2 pin in series when using them as general-purpose input pins.

- Differences between flash and mask ROM version

		System Reset Time State	After System Reset is Released
Flash ROM version LC87F2G08A	CF1/XT1	Set high via the internal Rf resistor	CF oscillation state
	CF2/XT2	Set high	CF oscillation state
Mask ROM version LC872G08A/06A/04A	CF1/XT1	Set low via the internal Rf resistor	CF oscillation state
	CF2/XT2	Set low	CF oscillation state

On-chip Debugger Pin Connection Requirements

For the treatment of the on-chip debugger pins, refer to the separately available documents entitled "RD87 on-chip debugger installation manual" and "LC872000 series on-chip debugger pin connection requirements"

LC87F2G08A

Absolute Maximum Ratings at Ta = 25°C, VSS1 = 0V

Parameter	Symbol	Pin/Remarks	Conditions	Specification				unit
				V _{DD} [V]	min	typ	max	
Maximum supply voltage	V _{DD} max	V _{DD} 1			-0.3		+6.5	V
Input voltage	V _I	CF1, CF2			-0.3		V _{DD} +0.3	
Input/output voltage	V _{IO}	Ports 0, 1, 2, P70			-0.3		V _{DD} +0.3	
High level output current	Peak output current	IOPH	Ports 0, 1, 2	CMOS output select Per 1 applicable pin		-10		mA
	Mean output current (Note 1-1)	IOMH	Ports 0, 1, 2	CMOS output select Per 1 applicable pin		-7.5		
	Total output current	ΣIOAH(1)	P10 to P14	Total of all applicable pins			-20	
Ports 0, 2, P15 to P17			Total of all applicable pins			-20		
Ports 0, 1, 2			Total of all applicable pins			-25		
Low level output current	Peak output current	IOPL(1)	P02 to P07 Ports 1, 2	Per 1 applicable pin			20	
		IOPL(2)	P00, P01	Per 1 applicable pin			30	
		IOPL(3)	P70	Per 1 applicable pin			10	
	Mean output current (Note 1-1)	IOML(1)	P02 to P07 Ports 1, 2	Per 1 applicable pin				
		IOML(2)	P00, P01	Per 1 applicable pin				20
		IOML(3)	P70	Per 1 applicable pin				7.5
	Total output current	ΣIOAL(1)	P10 to P14	Total of all applicable pins				50
		ΣIOAL(2)	Port 0, 2, P15 to P17	Total of all applicable pins				60
ΣIOAL(3)		Ports 0, 1, 2	Total of all applicable pins				70	
ΣIOAL(4)		P70	Total of all applicable pins				7.5	
Power Dissipation	Pd max(1)	MFP24S(300mil)		Ta=-40 to +85°C Package only			129	mW
	Pd max(2)			Ta=-40 to +85°C Package with thermal resistance board (Note 1-2)			229	
	Pd max(3)	MFP24SJ(300mil)		Ta=-40 to +85°C Package only			171	
	Pd max(4)			Ta=-40 to +85°C Package with thermal resistance board (Note 1-2)			393	
	Pd max(5)	SSOP24(225mil)		Ta=-40 to +85°C Package only			111	
	Pd max(6)			Ta=-40 to +85°C Package with thermal resistance board (Note 1-2)			334	
	Pd max(7)	VCT24(3.5×3.5)		Ta=-40 to +85°C Package only			T.B.D	
	Pd max(8)			Ta=-40 to +85°C Package with thermal resistance board			T.B.D	
Operating ambient temperature	T _{opr}				-40		+85	°C
Storage ambient temperature	T _{stg}				-55		+125	

Note 1-1: The mean output current is a mean value measured over 100ms.

Note 1-2: SEMI standards thermal resistance board (size: 76.1×114.3×1.6mm, glass epoxy) is used.

Stresses exceeding Maximum Ratings may damage the device. Maximum Ratings are stress ratings only. Functional operation above the Recommended Operating Conditions is not implied. Extended exposure to stresses above the Recommended Operating Conditions may affect device reliability.

LC87F2G08A

Allowable Operating Conditions at Ta = -40°C to +85°C, VSS1 = 0V

Parameter	Symbol	Pin/Remarks	Conditions	Specification				unit
				VDD[V]	min	typ	max	
Operating supply voltage (Note 2-1)	VDD(1)	VDD1	0.245μs ≤ tCYC ≤ 200μs		2.7		5.5	V
	VDD(2)		0.294μs ≤ tCYC ≤ 200μs		2.2		5.5	
	VDD(3)		0.735μs ≤ tCYC ≤ 200μs		1.8		5.5	
Memory sustaining supply voltage	VHD	VDD1	RAM and register contents sustained in HOLD mode.		1.6			
High level input voltage	VIH(1)	Ports 1, 2, P70 port input/ interrupt side		1.8 to 5.5	0.3VDD+0.7		VDD	
	VIH(2)	Ports 0		1.8 to 5.5	0.3VDD+0.7		VDD	
	VIH(3)	Port 70 watchdog timer side		1.8 to 5.5	0.9VDD		VDD	
	VIH(4)	CF1, RES		1.8 to 5.5	0.75VDD		VDD	
Low level input voltage	VIL(1)	Ports 1, 2, P70 port input/ interrupt side		4.0 to 5.5	VSS		0.1VDD+0.4	
				1.8 to 4.0	VSS		0.2VDD	
	VIL(2)	Ports 0		4.0 to 5.5	VSS		0.15VDD+0.4	
				1.8 to 4.0	VSS		0.2VDD	
	VIL(3)	Port 70 watchdog timer side		1.8 to 5.5	VSS		0.8VDD-1.0	
VIL(4)	CF1, RES		1.8 to 5.5	VSS		0.25VDD		
Instruction cycle time (Note 2-1)	tCYC (Note 2-2)			2.7 to 5.5	0.245		200	μs
				2.2 to 5.5	0.294		200	
				1.8 to 5.5	0.735		200	
External system clock frequency	FEXCF	CF1	<ul style="list-style-type: none"> • CF2 pin open • System clock frequency division ratio=1/1 • External system clock duty=50±5% 	2.7 to 5.5	0.1		12	MHz
				1.8 to 5.5	0.1		4	
				3.0 to 5.5	0.2		24.4	
Oscillation frequency range (Note 2-3)	FmCF(1)	CF1, CF2	12MHz ceramic oscillation. See Fig. 1.	2.7 to 5.5		12		MHz
	FmCF(2)	CF1, CF2	10MHz ceramic oscillation. See Fig. 1.	2.2 to 5.5		10		
	FmCF(3)	CF1, CF2	4MHz ceramic oscillation. CF oscillation normal amplifier size selected. (CFLAMP=0) See Fig. 1.	1.8 to 5.5		4		
			4MHz ceramic oscillation. CF oscillation low amplifier size selected. (CFLAMP=1) See Fig. 1.	2.2 to 5.5		4		
	FmMRC		Frequency variable RC oscillation. 1/2 frequency division ration. (RCCTD=0) (Note 2-4)	2.7 to 5.5	7.44	8.0	8.56	
	FmRC		Internal medium-speed RC oscillation	1.8 to 5.5	0.5	1.0	2.0	
	FmSRC		Internal low-speed RC oscillation	1.8 to 5.5	50	100	200	
FsX'tal	XT1, XT2		32.768kHz crystal oscillation See Fig. 2.	1.8 to 5.5		32.768		kHz

Note 2-1: VDD must be held greater than or equal to 2.2V in the flash ROM onboard programming mode.

Note 2-2: Relationship between tCYC and oscillation frequency is 3/FmCF at a division ratio of 1/1 and 6/FmCF at a division ratio of 1/2.

Note 2-3: See Tables 1 and 2 for the oscillation constants.

Note 2-4: When switching the system clock, allow an oscillation stabilization time of 100μs or longer after the multifrequency RC oscillator circuit transmits from the "oscillation stopped" to "oscillation enabled" state.

LC87F2G08A

Electrical Characteristics at Ta = -40°C to +85°C, VSS1 = 0V

Parameter	Symbol	Pin/Remarks	Conditions	Specification				
				VDD[V]	min	typ	max	unit
High level input current	I _{IH} (1)	Ports 0, 1, 2, P70, $\overline{\text{RES}}$	Output disabled Pull-up resistor off V _{IN} =V _{DD} (Including output Tr's off leakage current)	1.8 to 5.5			1	μA
	I _{IH} (2)	CF1	V _{IN} =V _{DD}	1.8 to 5.5			15	
Low level input current	I _{IL} (1)	Ports 0, 1, 2, P70, $\overline{\text{RES}}$	Output disabled Pull-up resistor off V _{IN} =V _{SS} (Including output Tr's off leakage current)	1.8 to 5.5	-1			μA
	I _{IL} (2)	CF1	V _{IN} =V _{SS}	1.8 to 5.5	-15			
High level output voltage	V _{OH} (1)	Ports 0, 1, 2	I _{OH} =-1mA	4.5 to 5.5	V _{DD} -1			V
	V _{OH} (2)		I _{OH} =-0.35mA	2.7 to 5.5	V _{DD} -0.4			
	V _{OH} (3)		I _{OH} =-0.15mA	1.8 to 5.5	V _{DD} -0.4			
Low level output voltage	V _{OL} (1)	Ports 0, 1, 2	I _{OL} =10mA	4.5 to 5.5			1.5	V
	V _{OL} (2)		I _{OL} =1.4mA	2.7 to 5.5			0.4	
	V _{OL} (3)		I _{OL} =0.8mA	1.8 to 5.5			0.4	
	V _{OL} (4)	P70	I _{OL} =1.4mA	2.7 to 5.5			0.4	
	V _{OL} (5)		I _{OL} =0.8mA	1.8 to 5.5			0.4	
	V _{OL} (6)	P00, P01	I _{OL} =25mA	4.5 to 5.5			1.5	
	V _{OL} (7)		I _{OL} =4mA	2.7 to 5.5			0.4	
	V _{OL} (8)		I _{OL} =2mA	1.8 to 5.5			0.4	
Pull-up resistance	R _{pu} (1)	Ports 0, 1, 2 P70	V _{OH} =0.9V _{DD} When Port 0 selected low-impedance pull-up.	4.5 to 5.5	15	35	80	kΩ
	R _{pu} (2)		V _{OH} =0.9V _{DD} When Port 0 selected high-impedance pull-up.	1.8 to 4.5	18	50	230	
	R _{pu} (3)	Port 0	V _{OH} =0.9V _{DD} When Port 0 selected high-impedance pull-up.	1.8 to 5.5	100	210	400	
Hysteresis voltage	V _{HYS} (1)	Ports 1, 2, P70, $\overline{\text{RES}}$		2.7 to 5.5		0.1V _{DD}		V
	V _{HYS} (2)			1.8 to 2.7		0.07V _{DD}		
Pin capacitance	CP	All pins	For pins other than that under test: V _{IN} =V _{SS} f=1MHz Ta=25°C	1.8 to 5.5		10		pF

LC87F2G08A

Serial I/O Characteristics at Ta = -40°C to +85°C, VSS1 = 0V

1. SIO0 Serial I/O Characteristics (Note 4-1-1)

Parameter		Symbol	Pin/ Remarks	Conditions	V _{DD} [V]	Specification				
						min	typ	max	unit	
Serial clock	Input clock	Frequency	tSCK(1)	SCK0(P12)	• See Fig. 5.	1.8 to 5.5	2			tCYC
		Low level pulse width	tSCKL(1)				1			
		High level pulse width	tSCKH(1)				1			
	Output clock	Frequency	tSCK(2)	SCK0(P12)	• CMOS output selected • See Fig. 5.	1.8 to 5.5	4/3			tSCK
		Low level pulse width	tSCKL(2)				1/2			
		High level pulse width	tSCKH(2)				1/2			
Serial input	Data setup time	tsDI(1)	SB0(P11), SIO(P11)	• Must be specified with respect to rising edge of SIOCLK. • See Fig. 5.	1.8 to 5.5	0.05				
	Data hold time	thDI(1)				0.05				
Serial output	Input clock	Output delay time	tdD0(1)	SO0(P10), SB0(P11)	• Continuous data transmission/reception mode (Note 4-1-2) • Synchronous 8-bit mode (Note 4-1-2) (Note 4-1-2)	1.8 to 5.5			(1/3)tCYC +0.08	μs
			tdD0(2)						1tCYC +0.08	
	Output clock	tdD0(3)						(1/3)tCYC +0.08		

Note 4-1-1: These specifications are theoretical values. Add margin depending on its use.

Note 4-1-2: Must be specified with respect to falling edge of SIOCLK. Must be specified as the time to the beginning of output state change in open drain output mode. See Fig. 5.

2. SIO1 Serial I/O Characteristics (Note 4-2-1)

Parameter		Symbol	Pin/ Remarks	Conditions	V _{DD} [V]	Specification				
						min	typ	max	unit	
Serial clock	Input clock	Frequency	tSCK(3)	SCK1(P15)	See Fig. 5.	1.8 to 5.5	2			tCYC
		Low level pulse width	tSCKL(3)				1			
		High level pulse width	tSCKH(3)				1			
	Output clock	Frequency	tSCK(4)	SCK1(P15)	• CMOS output selected • See Fig. 5.	1.8 to 5.5	2			tSCK
		Low level pulse width	tSCKL(4)				1/2			
		High level pulse width	tSCKH(4)				1/2			
Serial input	Data setup time	tsDI(2)	SB1(P14), S11(P14)	• Must be specified with respect to rising edge of SIOCLK. • See Fig. 5.	1.8 to 5.5	0.05				
	Data hold time	thDI(2)				0.05				
Serial output	Output delay time	tdD0(4)	SO1(P13), SB1(P14)	• Must be specified with respect to falling edge of SIOCLK. • Must be specified as the time to the beginning of output state change in open drain output mode. • See Fig. 5.	1.8 to 5.5			(1/3)tCYC +0.08	μs	

Note 4-2-1: These specifications are theoretical values. Add margin depending on its use.

LC87F2G08A

Pulse Input Conditions at Ta = -40°C to +85°C, V_{SS1} = 0V

Parameter	Symbol	Pin/Remarks	Conditions	Specification				
				V _{DD} [V]	min	typ	max	unit
High/low level pulse width	tPIH(1) tPIL(1)	INT0(P70), INT1(P17), INT2(P16), INT4(P20 to P21)	<ul style="list-style-type: none"> Interrupt source flag can be set. Event inputs for timer 0 or 1 are enabled. 	1.8 to 5.5	1			tCYC
	tPIH(2) tPIL(2)	INT3(P15) when noise filter time constant is 1/1	<ul style="list-style-type: none"> Interrupt source flag can be set. Event inputs for timer 0 are enabled. 	1.8 to 5.5	2			
	tPIH(3) tPIL(3)	INT3(P15) when noise filter time constant is 1/32	<ul style="list-style-type: none"> Interrupt source flag can be set. Event inputs for timer 0 are enabled. 	1.8 to 5.5	64			
	tPIH(4) tPIL(4)	INT3(P15) when noise filter time constant is 1/128	<ul style="list-style-type: none"> Interrupt source flag can be set. Event inputs for timer 0 are enabled. 	1.8 to 5.5	256			
	tPIL(5)	$\overline{\text{RES}}$	<ul style="list-style-type: none"> Resetting is enabled. 	1.8 to 5.5	200			μs

LC87F2G08A

AD Converter Characteristics at $V_{SS1} = 0V$

<12bits AD Converter Mode/ $T_a = -40^{\circ}C$ to $+85^{\circ}C$ >

Parameter	Symbol	Pin/Remarks	Conditions	Specification				
				$V_{DD}[V]$	min	typ	max	unit
Resolution	N	AN0(P00) to		2.4 to 5.5		12		bit
Absolute accuracy	ET	AN6(P06) AN8(P70)	(Note 6-1)	3.0 to 5.5			± 16	LSB
			(Note 6-1) • $T_a = -10$ to $+50^{\circ}C$	2.4 to 3.6			± 20	
Conversion time	TCAD		• See Conversion time calculation formulas. (Note 6-2)	4.0 to 5.5	32		115	μs
				3.0 to 5.5	64		115	
			• See Conversion time calculation formulas. (Note 6-2) • $T_a = -10$ to $+50^{\circ}C$	2.4 to 3.6	410		425	
Analog input voltage range	VAIN			2.4 to 5.5	V_{SS}		V_{DD}	V
Analog port input current	I _{AINH}		$V_{AIN} = V_{DD}$	2.4 to 5.5			1	μA
	I _{AINL}		$V_{AIN} = V_{SS}$	2.4 to 5.5	-1			

<8bits AD Converter Mode/ $T_a = -40^{\circ}C$ to $+85^{\circ}C$ >

Parameter	Symbol	Pin/Remarks	Conditions	Specification				
				$V_{DD}[V]$	min	typ	max	unit
Resolution	N	AN0(P00) to		2.4 to 5.5		8		bit
Absolute accuracy	ET	AN6(P06) AN8(P70)	(Note 6-1)	2.4 to 5.5			± 1.5	LSB
Conversion time	TCAD		• See Conversion time calculation formulas. (Note 6-2)	4.0 to 5.5	20		90	μs
				3.0 to 5.5	40		90	
			• See Conversion time calculation formulas. (Note 6-2) • $T_a = -10$ to $+50^{\circ}C$	2.4 to 3.6	250		265	
Analog input voltage range	VAIN			2.4 to 5.5	V_{SS}		V_{DD}	V
Analog port input current	I _{AINH}		$V_{AIN} = V_{DD}$	2.4 to 5.5			1	μA
	I _{AINL}		$V_{AIN} = V_{SS}$	2.4 to 5.5	-1			

Note 6-1: The quantization error ($\pm 1/2LSB$) must be excluded from the absolute accuracy. The absolute accuracy must be measured in the microcontroller's state in which no I/O operations occur at the pins adjacent to the analog input channel.

Note 6-2: The conversion time refers to the period from the time an instruction for starting a conversion process till the time the conversion results register(s) are loaded with a complete digital conversion value corresponding to the analog input value.

The conversion time is 2 times the normal-time conversion time when:

- The first AD conversion is performed in the 12-bit AD conversion mode after a system reset.
- The first AD conversion is performed after the AD conversion mode is switched from 8-bit to 12-bit conversion mode.

Conversion time calculation formulas:

$$12\text{bits AD Converter Mode: } TCAD(\text{Conversion time}) = ((52/(\text{AD division ratio}))+2) \times (1/3) \times tCYC$$

$$8\text{bits AD Converter Mode: } TCAD(\text{Conversion time}) = ((32/(\text{AD division ratio}))+2) \times (1/3) \times tCYC$$

External oscillation (F _m CF)	Operating supply voltage range (V_{DD})	System division ratio (SYS _{DIV})	Cycle time (t _{CYC})	AD division ratio (AD _{DIV})	AD conversion time (TCAD)	
					12bit AD	8bit AD
CF-12MHz	4.0V to 5.5V	1/1	250ns	1/8	34.8 μs	21.5 μs
	3.0V to 5.5V	1/1	250ns	1/16	69.5 μs	42.8 μs
CF-10MHz	4.0V to 5.5V	1/1	300ns	1/8	41.8 μs	25.8 μs
	3.0V to 5.5V	1/1	300ns	1/16	83.4 μs	51.4 μs
CF-4MHz	3.0V to 5.5V	1/1	750ns	1/8	104.5 μs	64.5 μs
	2.4V to 3.6V	1/1	750ns	1/32	416.5 μs	256.5 μs

LC87F2G08A

Power-on Reset (POR) Characteristics at Ta = -40°C to +85°C, VSS1 = 0V

Parameter	Symbol	Pin/Remarks	Conditions	Specification				
				Option selected voltage	min	typ	max	unit
POR release voltage	PORRL		<ul style="list-style-type: none"> Select from option. (Note 7-1) 	1.67V	1.55	1.67	1.79	V
				1.97V	1.85	1.97	2.09	
				2.07V	1.95	2.07	2.19	
				2.37V	2.25	2.37	2.49	
				2.57V	2.45	2.57	2.69	
				2.87V	2.75	2.87	2.99	
				3.86V	3.73	3.86	3.99	
				4.35V	4.21	4.35	4.49	
Detection voltage unknown state	POUKS		<ul style="list-style-type: none"> See Fig. 7. (Note 7-2) 			0.7	0.95	
Power supply rise time	PORIS		<ul style="list-style-type: none"> Power supply rise time from 0V to 1.6V. 				100	ms

Note7-1: The POR release level can be selected out of 8 levels only when the LVD reset function is disabled.

Note7-2: POR is in an unknown state before transistors start operation.

Low Voltage Detection Reset (LVD) Characteristics at Ta = -40°C to +85°C, VSS1=0V

Parameter	Symbol	Pin/Remarks	Conditions	Specification				
				Option selected voltage	min	typ	max	unit
LVD reset voltage (Note 8-2)	LVDET		<ul style="list-style-type: none"> Select from option. (Note 8-1) (Note 8-3) See Fig. 8. 	1.91V	1.81	1.91	2.01	V
				2.01V	1.91	2.01	2.11	
				2.31V	2.21	2.31	2.41	
				2.51V	2.41	2.51	2.61	
				2.81V	2.71	2.81	2.91	
				3.79V	3.69	3.79	3.89	
				4.28V	4.18	4.28	4.38	
LVD hysteresys width	LVHYS			1.91V		55		mV
				2.01V		55		
				2.31V		55		
				2.51V		55		
				2.81V		60		
				3.79V		65		
Detection voltage unknown state	LVUKS		<ul style="list-style-type: none"> See Fig. 8. (Note 8-4) 			0.7	0.95	V
Low voltage detection minimum width (Reply sensitivity)	TLVDW		<ul style="list-style-type: none"> LVDET-0.5V See Fig. 9. 		0.2			ms

Note8-1: The LVD reset level can be selected out of 7 levels only when the LVD reset function is enabled.

Note8-2: LVD reset voltage specification values do not include hysteresis voltage.

Note8-3: LVD reset voltage may exceed its specification values when port output state changes and/or when a large current flows through port.

Note8-4: LVD is in an unknown state before transistors start operation.

LC87F2G08A

Consumption Current Characteristics at Ta = -40°C to +85°C, VSS1 = 0V

Parameter	Symbol	Pin/ Remarks	Conditions	Specification				
				V _{DD} [V]	min	typ	max	unit
Normal mode consumption current (Note 9-1) (Note 9-2)	IDDOP(1)	V _{DD} 1	<ul style="list-style-type: none"> FmCF=12MHz ceramic oscillation mode System clock set to 12MHz side Internal low speed and medium speed RC oscillation stopped. 	2.7 to 5.5		7.4	13.0	mA
				2.7 to 3.6		4.4	8.1	
	IDDOP(2)		<ul style="list-style-type: none"> CF1=24MHz external clock System clock set to CF1 side Internal low speed and medium speed RC oscillation stopped. 	3.0 to 5.5		9.7	16.2	
				3.0 to 3.6		5.3	8.7	
	IDDOP(3)		<ul style="list-style-type: none"> FmCF=10MHz ceramic oscillation mode System clock set to 10MHz side Internal low speed and medium speed RC oscillation stopped. 	2.2 to 5.5		6.6	11.9	
				2.2 to 3.6		4.0	7.4	
	IDDOP(4)		<ul style="list-style-type: none"> FmCF=4MHz ceramic oscillation mode System clock set to 4MHz side Internal low speed and medium speed RC oscillation stopped. 	1.8 to 5.5		2.9	6.5	
				1.8 to 3.6		2.2	4.2	
	IDDOP(5)		<ul style="list-style-type: none"> CF oscillation low amplifier size selected. (CFLAMP=1) FmCF=4MHz ceramic oscillation mode System clock set to 4MHz side 	2.2 to 5.5		1.1	2.5	
				2.2 to 3.6		0.6	1.3	
	IDDOP(6)		<ul style="list-style-type: none"> FsX'tal=32.768kHz crystal oscillation mode Internal low speed RC oscillation stopped. 	1.8 to 5.5		0.6	1.7	
				1.8 to 3.6		0.3	0.9	
	IDDOP(7)		<ul style="list-style-type: none"> FsX'tal=32.768kHz crystal oscillation mode Internal low speed and medium speed RC oscillation stopped. 	2.7 to 5.5		5.0	9.1	
				2.7 to 3.6		3.6	5.8	
	IDDOP(8)		<ul style="list-style-type: none"> External FsX'tal and FmCF oscillation stopped. System clock set to internal low speed RC oscillation. 	1.8 to 5.5		75	370	
				1.8 to 3.6		46	192	
IDDOP(9)	<ul style="list-style-type: none"> External FsX'tal and FmCF oscillation stopped. System clock set to internal low speed RC oscillation. 	5.0		75	176			
		3.3		46	115			
		2.5		35	85			
			<ul style="list-style-type: none"> Internal medium speed RC oscillation stopped. Frequency variable RC oscillation stopped. 1/1 frequency division ratio Ta=-10 to +50°C 					μA

Note9-1: Values of the consumption current do not include current that flows into the output transistors and internal pull-up resistors.

Note9-2: The consumption current values do not include operational current of LVD function if not specified.

Continued on next page.

LC87F2G08A

Continued from preceding page.

Parameter	Symbol	Pin/ Remarks	Conditions	Specification				
				V _{DD} [V]	min	typ	max	unit
Normal mode consumption current (Note 9-1) (Note 9-2)	IDDOP(10)	V _{DD1}	<ul style="list-style-type: none"> FsX'tal=32.768kHz crystal oscillation mode System clock set to 32.768kHz side Internal low speed and medium speed RC oscillation stopped. 	1.8 to 5.5		38	139	μA
				1.8 to 3.6		15	66	
	IDDOP(11)		<ul style="list-style-type: none"> FsX'tal=32.768kHz crystal oscillation mode System clock set to 32.768kHz side Internal low speed and medium speed RC oscillation stopped. Frequency variable RC oscillation stopped. 1/2 frequency division ratio 	5.0		38	101	
				3.3		15	46	
HALT mode consumption current (Note 9-1) (Note 9-2)	IDDHALT(1)	V _{DD1}	<ul style="list-style-type: none"> HALT mode FmCF=12MHz ceramic oscillation mode System clock set to 12MHz side Internal low speed and medium speed RC oscillation stopped. 	2.7 to 5.5		3.1	5.6	mA
				2.7 to 3.6		1.6	2.9	
	IDDHALT(2)		<ul style="list-style-type: none"> HALT mode CF1=24MHz external clock System clock set to CF1 side Internal low speed and medium speed RC oscillation stopped. Frequency variable RC oscillation stopped. 1/2 frequency division ratio 	3.0 to 5.5		4.9	8.6	
				3.0 to 3.6		2.3	3.8	
	IDDHALT(3)		<ul style="list-style-type: none"> HALT mode FmCF=10MHz ceramic oscillation mode System clock set to 10MHz side Internal low speed and medium speed RC oscillation stopped. Frequency variable RC oscillation stopped. 1/1 frequency division ratio 	2.2 to 5.5		2.7	5.3	
				2.2 to 3.6		1.4	2.6	
	IDDHALT(4)		<ul style="list-style-type: none"> HALT mode FmCF=4MHz ceramic oscillation mode System clock set to 4MHz side Internal low speed and medium speed RC oscillation stopped. Frequency variable RC oscillation stopped. 1/1 frequency division ratio 	1.8 to 5.5		1.4	3.5	
				1.8 to 3.6		0.7	1.3	
	IDDHALT(5)		<ul style="list-style-type: none"> HALT mode CF oscillation low amplifier size selected. (CFLAMP=1) FmCF=4MHz ceramic oscillation mode System clock set to 4MHz side Internal low speed and medium speed RC oscillation stopped. Frequency variable RC oscillation stopped. 1/4 frequency division ratio 	2.2 to 5.5		0.7	1.8	
				2.2 to 3.6		0.3	0.7	
	IDDHALT(6)		<ul style="list-style-type: none"> HALT mode FsX'tal=32.768kHz crystal oscillation mode Internal low speed RC oscillation stopped. System clock set to internal medium speed RC oscillation Frequency variable RC oscillation stopped. 1/2 frequency division ratio 	1.8 to 5.5		0.4	1.1	
				1.8 to 3.6		0.2	0.5	

Note9-1: Values of the consumption current do not include current that flows into the output transistors and internal pull-up resistors.

Note9-2: The consumption current values do not include operational current of LVD function if not specified.

Continued on next page.

LC87F2G08A

Continued from preceding page.

Parameter	Symbol	Pin/ remarks	Conditions	Specification				
				V _{DD} [V]	min	typ	max	unit
HALT mode consumption current (Note 9-1) (Note 9-2)	IDDHALT(7)	V _{DD1}	<ul style="list-style-type: none"> • HALT mode • FsX'tal=32.768kHz crystal oscillation mode • Internal low speed and medium speed RC oscillation stopped. • System clock set to 8MHz with frequency variable RC oscillation • 1/1 frequency division ratio 	2.7 to 5.5		1.8	3.5	mA
				2.7 to 3.6		1.1	2.0	
	IDDHALT(8)		<ul style="list-style-type: none"> • HALT mode • External FsX'tal and FmCF oscillation stopped. • System clock set to internal low speed RC oscillation. • Internal medium speed RC oscillation stopped. • Frequency variable RC oscillation stopped. • 1/1 frequency division ratio 	1.8 to 5.5		23	260	μA
				1.8 to 3.6		13	119	
	IDDHALT(9)		<ul style="list-style-type: none"> • HALT mode • External FsX'tal and FmCF oscillation stopped. • System clock set to internal low speed RC oscillation. • Internal medium speed RC oscillation stopped. • Frequency variable RC oscillation stopped. • 1/1 frequency division ratio • Ta=-10 to +50°C 	5.0		23	65	
				3.3		13	35	
				2.5		9.2	25	
	IDDHALT(10)		<ul style="list-style-type: none"> • HALT mode • FsX'tal=32.768kHz crystal oscillation mode • System clock set to 32.768kHz side • Internal low speed and medium speed RC oscillation stopped. • Frequency variable RC oscillation stopped. • 1/2 frequency division ratio 	1.8 to 5.5		25	112	
				1.8 to 3.6		8.5	56	
	IDDHALT(11)		<ul style="list-style-type: none"> • HALT mode • FsX'tal=32.768kHz crystal oscillation mode • System clock set to 32.768kHz side • Internal low speed and medium speed RC oscillation stopped. • Frequency variable RC oscillation stopped. • 1/2 frequency division ratio • Ta=-10 to +50°C 	5.0		25	69	
				3.3		8.5	29	
				2.5		4.2	15	
HOLD mode consumption current (Note 9-1) (Note 9-2)	IDDHOLD(1)	HOLD mode	<ul style="list-style-type: none"> • CF1=V_{DD} or open (External clock mode) 	1.8 to 5.5		0.04	30	
				1.8 to 3.6		0.02	21	
	IDDHOLD(2)		<ul style="list-style-type: none"> • CF1=V_{DD} or open (External clock mode) • Ta=-10 to +50°C 	5.0		0.04	2.3	
				3.3		0.02	1.5	
				2.5		0.017	1.2	
	IDDHOLD(3)		<ul style="list-style-type: none"> • CF1=V_{DD} or open (External clock mode) • LVD option selected 	1.8 to 5.5		3.2	35	
				1.8 to 3.6		2.7	24	
	IDDHOLD(4)		<ul style="list-style-type: none"> • CF1=V_{DD} or open (External clock mode) • Ta=-10 to +50°C • LVD option selected 	5.0		3.2	6.5	
3.3				2.7	4.5			
2.5				2.5	4.2			
Timer HOLD mode consumption current (Note 9-1) (Note 9-2)	IDDHOLD(5)	Timer HOLD mode	<ul style="list-style-type: none"> • FsX'tal=32.768 kHz crystal oscillation mode 	1.8 to 5.5		22	106	
				1.8 to 3.6		7.5	45	
	IDDHOLD(6)		<ul style="list-style-type: none"> • FsX'tal=32.768kHz crystal oscillation mode • Ta=-10 to +50°C 	5.0		22	62	
				3.3		7.5	23	
				2.5		2.9	12	

Note9-1: Values of the consumption current do not include current that flows into the output transistors and internal pull-up resistors.

Note9-2: The consumption current values do not include operational current of LVD function if not specified.

LC87F2G08A

F-ROM Programming Characteristics at Ta = +10°C to +55°C, VSS1 = 0V

Parameter	Symbol	Pin/Remarks	Conditions	Specification				
				V _{DD} [V]	min	typ	max	unit
Onboard programming current	IDDFW(1)	V _{DD1}	• Only current of the Flash block.	2.2 to 5.5		5	10	mA
Programming time	tFW(1)		• Erasing time	2.2 to 5.5		20	30	ms
	tFW(2)		• Programming time			40	60	μs

UART (Full Duplex) Operating Conditions at Ta = -40°C to +85°C, VSS1 = 0V

Parameter	Symbol	Pin/Remarks	Conditions	Specification				
				V _{DD} [V]	min	typ	max	unit
Transfer rate	UBR	UTX(P20) URX(P21)		1.8 to 5.5	16/3		8192/3	tCYC

Data length: 7/8/9 bits (LSB first)

Stop bits: 1 bit (2-bit in continuous data transmission)

Parity bits: None

Example of Continuous 8-bit Data Transmission Mode Processing (First Transmit Data=55H)

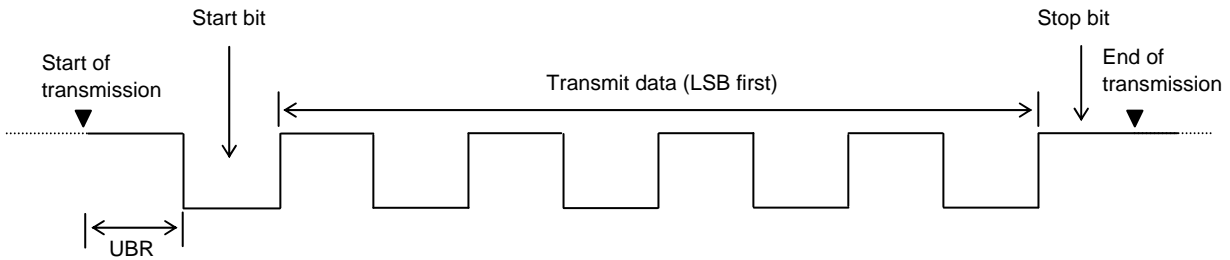

Example of Continuous 8-bit Data Reception Mode Processing (First Receive Data=55H)

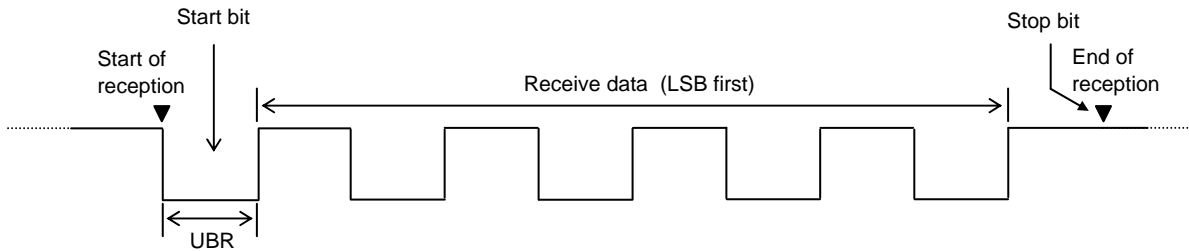

LC87F2G08A

Characteristics of a Sample Main System Clock Oscillation Circuit

Given below are the characteristics of a sample main system clock oscillation circuit that are measured using a Our designated oscillation characteristics evaluation board and external components with circuit constant values with which the oscillator vendor confirmed normal and stable oscillation.

Table 1 Characteristics of a Sample Main System Clock Oscillator Circuit with a Ceramic Oscillator

- CF oscillation normal amplifier size selected (CFLAMP=0)

■MURATA

Nominal Frequency	Type	Oscillator Name	Circuit Constant				Operating Voltage Range [V]	Oscillation Stabilization Time		Remarks
			C1 [pF]	C2 [pF]	Rf [Ω]	Rd [Ω]		typ [ms]	max [ms]	
12MHz	SMD	CSTCE12M0G52-R0	(10)	(10)	Open	1.0k	2.7 to 5.5	0.1	0.5	Internal C1, C2
10MHz	SMD	CSTCE10M0G52-R0	(10)	(10)	Open	680	2.2 to 3.6	0.1	0.5	
					Open	1.0k	2.3 to 5.5	0.1	0.5	
8MHz	SMD	CSTCE8M00G52-R0	(10)	(10)	Open	1.5k	2.2 to 5.5	0.1	0.5	
	LEAD	CSTLS8M00G53-B0	(15)	(15)	Open	1.0k	2.2 to 3.6	0.1	0.5	
6MHz	SMD	CSTCR6M00G53-R0	(15)	(15)	Open	2.2k	2.2 to 5.5	0.1	0.5	
	LEAD	CSTLS6M00G53-B0	(15)	(15)	Open	2.2k	2.2 to 5.5	0.1	0.5	
4MHz	SMD	CSTCR4M00G53-R0	(15)	(15)	Open	1.5k	1.8 to 2.7	0.2	0.6	
					Open	3.3k	1.9 to 5.5	0.2	0.6	
	LEAD	CSTLS4M00G53-B0	(15)	(15)	Open	3.3k	1.9 to 5.5	0.2	0.6	

- CF oscillation low amplifier size selected (CFLAMP=1)

■MURATA

Nominal Frequency	Type	Oscillator Name	Circuit Constant				Operating Voltage Range [V]	Oscillation Stabilization Time		Remarks
			C1 [pF]	C2 [pF]	Rf [Ω]	Rd [Ω]		typ [ms]	max [ms]	
4MHz	SMD	CSTCR4M00G53-R0	(15)	(15)	Open	1.0k	2.3 to 2.7	0.2	0.6	Internal C1,C2
					Open	2.2k	2.5 to 5.5	0.2	0.6	
		CSTCR4M00G53095-R0	(15)	(15)	Open	1.0k	2.1 to 2.7	0.2	0.7	
	LEAD	CSTLS4M00G53-B0	(15)	(15)	Open	1.0k	2.3 to 2.7	0.2	0.6	
					Open	2.2k	2.5 to 5.5	0.2	0.6	
		CSTLS4M00G53095-B0	(15)	(15)	Open	1.0k	2.1 to 2.7	0.2	0.7	

The oscillation stabilization time refers to the time interval that is required for the oscillation to get stabilized after V_{DD} goes above the operating voltage lower limit (see Figure 3).

LC87F2G08A

Characteristics of a Sample Subsystem Clock Oscillator Circuit

Given below are the characteristics of a sample subsystem clock oscillation circuit that are measured using a Our designated oscillation characteristics evaluation board and external components with circuit constant values with which the oscillator vendor confirmed normal and stable oscillation.

Table 2 Characteristics of a Sample Subsystem Clock Oscillator Circuit with a Crystal Oscillator

■EPSON TOYOCOM

Nominal Frequency	Type	Oscillator Name	Circuit Constant				Operating Voltage Range [V]	Oscillation Stabilization Time		Remarks
			C1 [pF]	C2 [pF]	Rf [Ω]	Rd [Ω]		typ [s]	max [s]	
32.768kHz	SMD	MC-306	9	9	Open	330k	1.8 to 5.5	1.4	4.0	Applicable CL value = 7.0pF

The oscillation stabilization time refers to the time interval that is required for the oscillation to get stabilized after the instruction for starting the subclock oscillation circuit is executed and to the time interval that is required for the oscillation to get stabilized after the HOLD mode is reset (see Figure 3).

Note: The components that are involved in oscillation should be placed as close to the IC and to one another as possible because they are vulnerable to the influences of the circuit pattern.

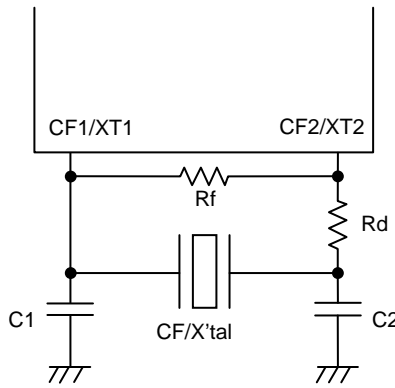

Figure 1 CF and XT Oscillator Circuit

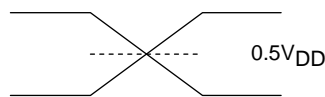
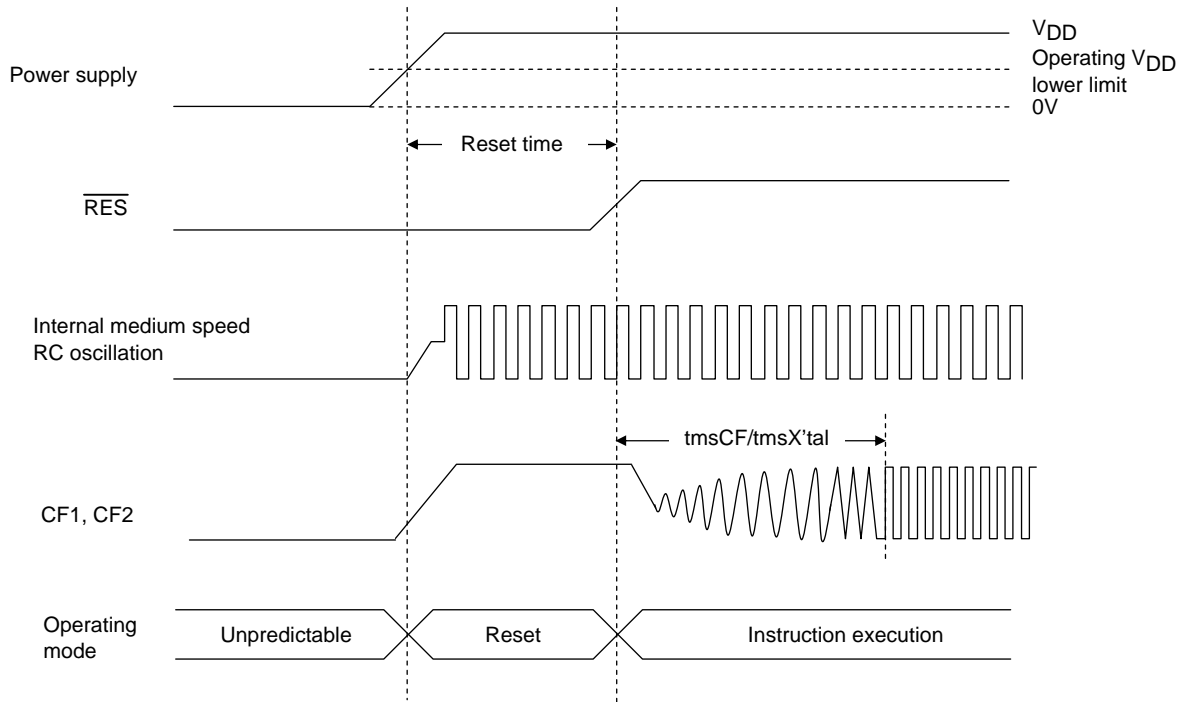
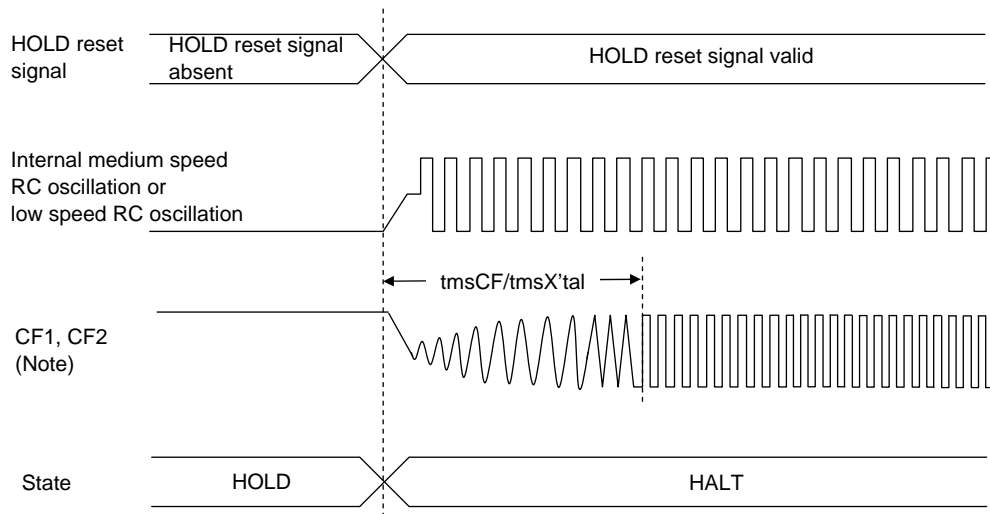

Figure 2 AC Timing Measurement Point

LC87F2G08A



Reset Time and Oscillation Stabilization Time



HOLD Reset Signal and Oscillation Stabilization Time

Note: External oscillation circuit is selected.

Figure 3 Oscillation Stabilization Times

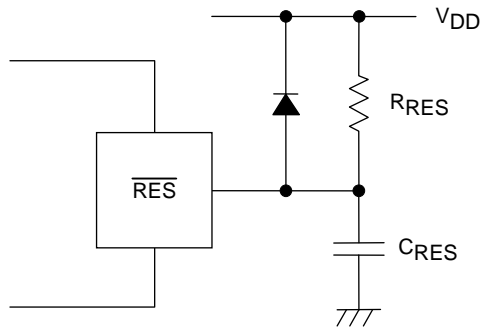

Note:
External circuits for reset may vary depending on the usage of POR and LVD. Please refer to the user's manual for more information.

Figure 4 Reset Circuit

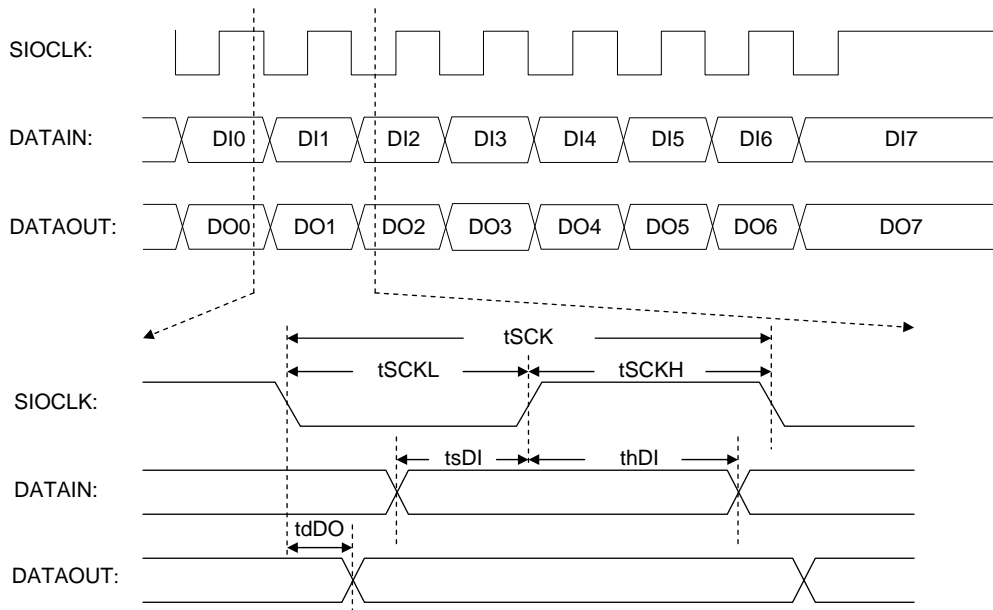

Figure 5 Serial I/O Output Waveforms

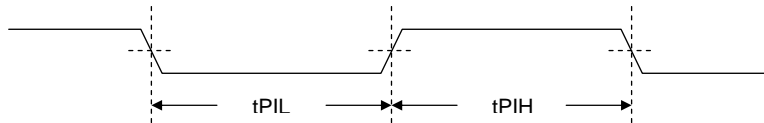

Figure 6 Pulse Input Timing Signal Waveform

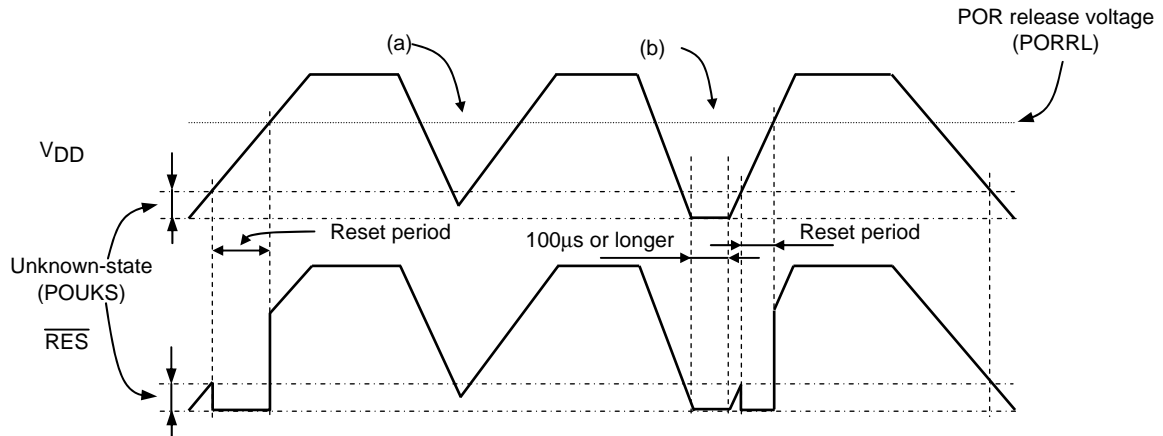

Figure 7 Waveform observed when only POR is used (LVD not used)
(RESET pin: Pull-up resistor R_{RES} only)

- The POR function generates a reset only when power is turned on starting at the V_{SS} level.
- No stable reset will be generated if power is turned on again when the power level does not go down to the V_{SS} level as shown in (a). If such a case is anticipated, use the LVD function together with the POR function or implement an external reset circuit.
- A reset is generated only when the power level goes down to the V_{SS} level as shown in (b) and power is turned on again after this condition continues for 100µs or longer.

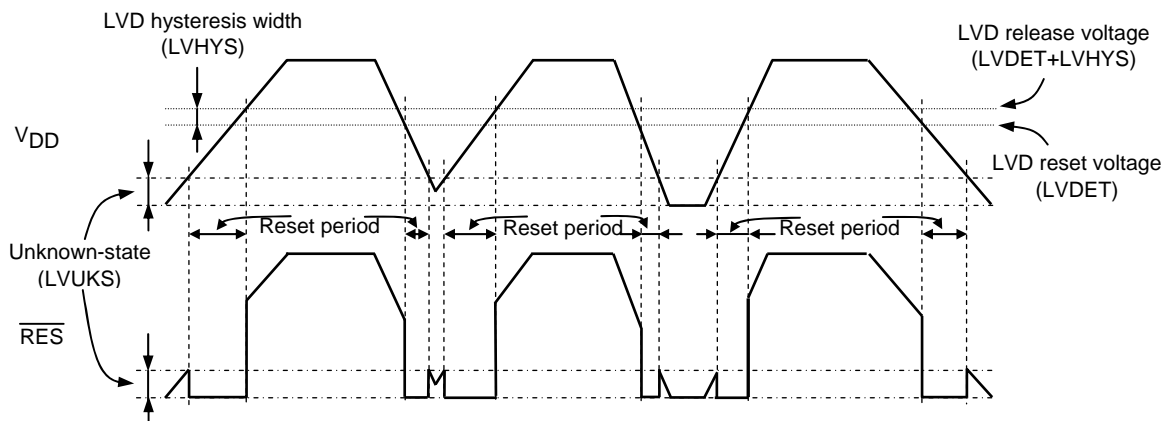

Figure 8 Waveform observed when both POR and LVD functions are used
(RESET pin: Pull-up resistor R_{RES} only)

- Resets are generated both when power is turned on and when the power level lowers.
- A hysteresis width (LVHYS) is provided to prevent the repetitions of reset release and entry cycles near the detection level.

X-ON Electronics

Largest Supplier of Electrical and Electronic Components

Click to view similar products for [8-bit Microcontrollers - MCU category](#):

Click to view products by [ON Semiconductor manufacturer](#):

Other Similar products are found below :

[CY8C20524-12PVXIT](#) [MB95F012KPFT-G-SNE2](#) [MB95F013KPMC-G-SNE2](#) [MB95F263KPF-G-SNE2](#) [MB95F264KPFT-G-SNE2](#)
[MB95F398KPMC-G-SNE2](#) [MB95F478KPMC2-G-SNE2](#) [MB95F564KPF-G-SNE2](#) [MB95F636KWQN-G-SNE1](#) [MB95F696KPMC-G-SNE2](#)
[MB95F698KPMC2-G-SNE2](#) [MB95F698KPMC-G-SNE2](#) [MB95F818KPMC1-G-SNE2](#) [901015X](#) [CY8C3MFIDOCK-125](#) [403708R](#)
[MB95F354EPF-G-SNE2](#) [MB95F564KWQN-G-SNE1](#) [MB95F636KP-G-SH-SNE2](#) [MB95F694KPMC-G-SNE2](#) [MB95F778JPMC1-G-SNE2](#)
[MB95F818KPMC-G-SNE2](#) [LC87F0G08AUJA-AH](#) [CP8361BT](#) [CG8421AF](#) [MB95F202KPF-G-SNE2](#) [DF36014FPV](#) [5962-8768407MUA](#)
[MB95F318EPMC-G-SNE2](#) [MB94F601APMC1-GSE1](#) [MB95F656EPF-G-SNE2](#) [LC78615E-01US-H](#) [LC87F5WC8AVU-QIP-H](#)
[MB95F108AJSPMC-G-JNE1](#) [73S1210F-68M/F/PJ](#) [MB89F538-101PMC-GE1](#) [LC87F7DC8AVU-QIP-H](#) [MB95F876KPMC-G-SNE2](#)
[MB88386PMC-GS-BNDE1](#) [LC87FBK08AU-SSOP-H](#) [LC87F2C64AU-QFP-H](#) [MB95F636KNWQN-G-118-SNE1](#) [MB95F136NBSTPFV-GS-](#)
[N2E1](#) [LC87F5NC8AVU-QIP-E](#) [CY8C20324-12LQXIT](#) [LC87F76C8AU-TQFP-E](#) [CG8581AA](#) [LC87F2G08AU-SSOP-E](#) [CP8085AT](#)
[ATTINY3224-SSU](#)