



ON Semiconductor®

<http://onsemi.com>

LC898212XD

CMOS LSI

AF Controller

Overview

This LSI is AF control LSI. It consists of 1 system of feed back circuit for AF control.

Features

- Built-in equalizer circuit using digital operation
 - AF control equalize circuit
 - Any coefficient can be specified by I²C I/F
- I²C Interface
- Built-in A/D converter
 - Maximum 10-bit
 - Input 2 channel
- Built-in D/A converter
 - 8-bit
 - Output 2-channel (Hall offset, Constant current Bias)
- Built-in OP Amp
 - 1 channel
 - Hall Amp
- Built-in OSC
 - 48MHz (Frequency adjustment function)
- Built-in PWM pulse generator circuit
 - PWM circuit for AF control
- 1-chip motor driver
 - Saturation drive H bridge 1 channel
- Package
 - WL-CSP 12-pin
 - Lead-free, halogen-free
- Supply voltage
 - Logic unit : Internal core typ 1.2V, AVDD (2.6V to 3.6V)
 - Driver unit : VM (2.6V to 3.6V)

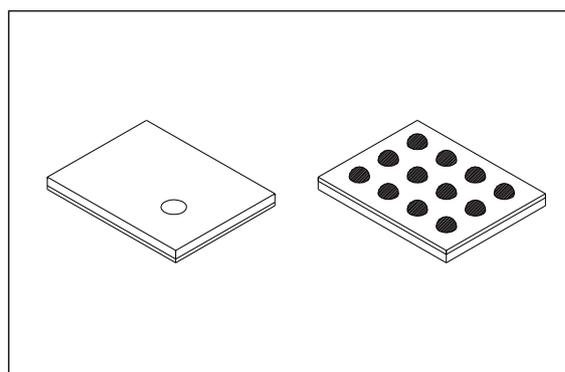

WLP12J(1.77X1.37)

* I²C Bus is a trademark of Philips Corporation.

ORDERING INFORMATION

See detailed ordering and shipping information on page 4 of this data sheet.

Pin Description

TYPE					
I	INPUT	P	Power supply, GND	NC	NOT CONNECT
O	OUTPUT				
B	BIDIRECTION				

- I²C interface

I2CCK	B	I ² C Clock pin
I2CDT	B	I ² C Data pin

- D/A interface

BIASO	O	D/A output (Hall bias input)
-------	---	------------------------------

- Op-Amp interface

OPINP	I	Op-Amp input
OPINM	I	Op-Amp input

- Driver interface

OUT1	O	Actuator output pin
OUT2	O	Actuator output pin

- Power supply pin

VDD	P	Digital power supply
VSS	P	Digital GND
VDDO	P	LDO power supply out
VM	P	Motor power supply
PGND	P	Power GND

PIN TYPE “O” – Ensure that it is set to OPEN.

PIN TYPE “I” – OPEN is inhibited. Ensure that it is connected to the VDD or VSS even when it is unused.

(Please contact our company for more information about selection of VDD or VSS.)

PIN TYPE “B” – If you are unsure about processing method on the pin description of pin layout table, please contact us.

Note that incorrect processing of unused pins may result in defects.

If you have any question, please feel free to contact us.

LC898212XD

Pin Layout

Circuit Name	Number of Pins	Circuit Name	Number of Pins
Analog	4	Driver	4
Logic	4		

Backside pin layout diagram (Top View from the mold side)

4	VDDO	VM	PGND
3	AVDD	I2CDT	OUT1
2	OPINP	I2CCK	OUT2
1	VSS	OPINM	BIASO
	A	B	C

Block Diagram

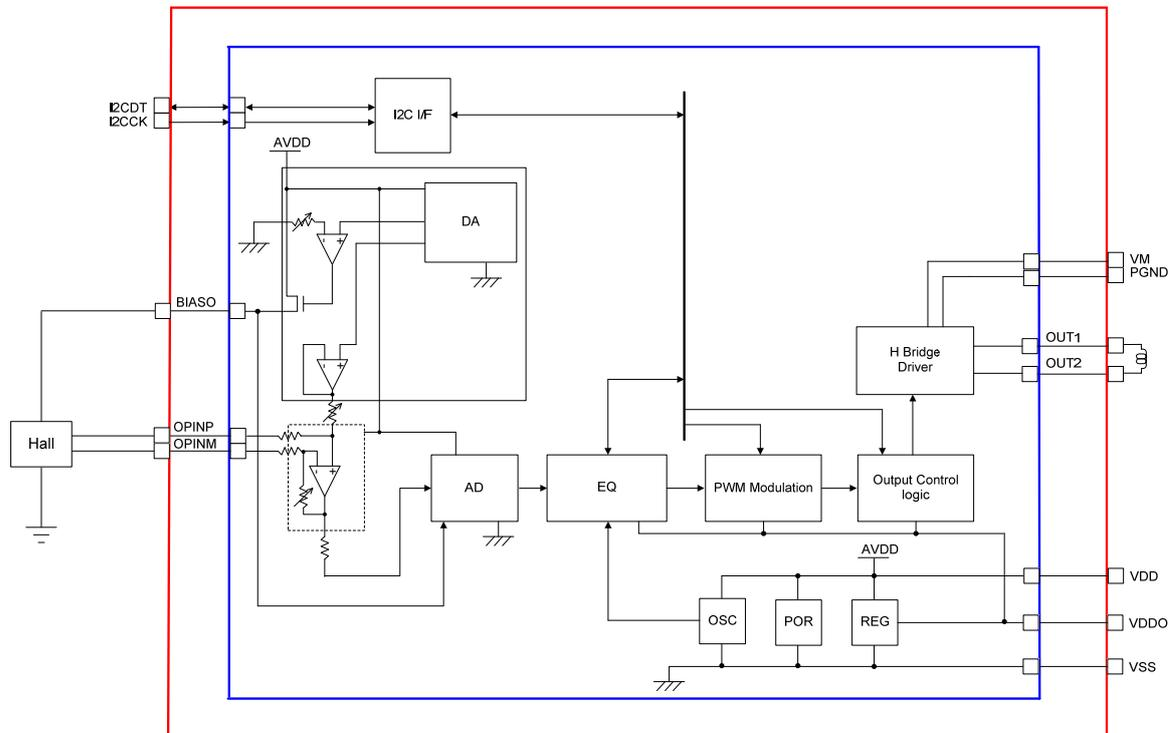

LC898212XD

Package Dimensions

WLP12J(1.77X1.37)

unit : mm

WLCSP12, 1.77x1.37

CASE 567GH

ISSUE O

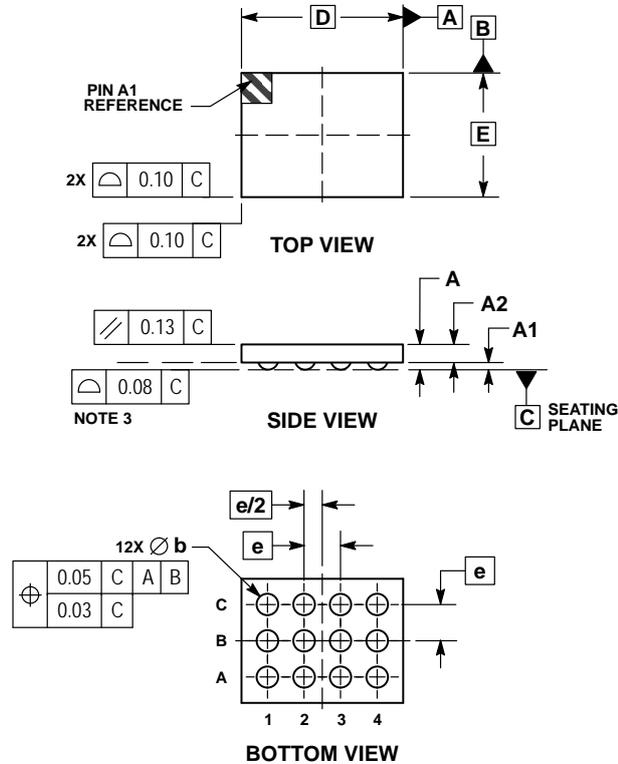

NOTES:

1. DIMENSIONING AND TOLERANCING PER ASME Y14.5M, 1994.
2. CONTROLLING DIMENSION: MILLIMETERS.
3. COPLANARITY APPLIES TO THE SPHERICAL CROWNS OF THE SOLDER BALLS.

DIM	MILLIMETERS	
	MIN	MAX
A	---	0.33
A1	0.03	0.13
A2	0.20 REF	
b	0.15	0.25
D	1.77 BSC	
E	1.37 BSC	
e	0.40 BSC	

RECOMMENDED SOLDERING FOOTPRINT*

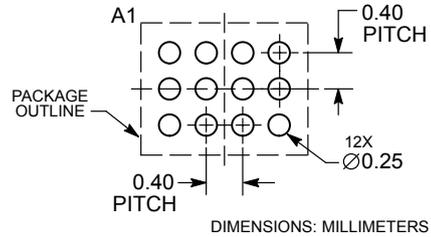

*For additional information on our Pb-Free strategy and soldering details, please download the ON Semiconductor Soldering and Mounting Techniques Reference Manual, SOLDERRM/D.

ORDERING INFORMATION

Device	Package	Shipping (Qty / Packing)
LC898212XD-SH	WLP12J(1.77X1.37) (Pb-Free / Halogen Free)	5000 / Tape & Reel

ON Semiconductor and the ON logo are registered trademarks of Semiconductor Components Industries, LLC (SCILLC). SCILLC owns the rights to a number of patents, trademarks, copyrights, trade secrets, and other intellectual property. A listing of SCILLC's product/patent coverage may be accessed at www.onsemi.com/site/pdf/Patent-Marking.pdf. SCILLC reserves the right to make changes without further notice to any products herein. SCILLC makes no warranty, representation or guarantee regarding the suitability of its products for any particular purpose, nor does SCILLC assume any liability arising out of the application or use of any product or circuit, and specifically disclaims any and all liability, including without limitation special, consequential or incidental damages. "Typical" parameters which may be provided in SCILLC data sheets and/or specifications can and do vary in different applications and actual performance may vary over time. All operating parameters, including "Typicals" must be validated for each customer application by customer's technical experts. SCILLC does not convey any license under its patent rights nor the rights of others. SCILLC products are not designed, intended, or authorized for use as components in systems intended for surgical implant into the body, or other applications intended to support or sustain life, or for any other application in which the failure of the SCILLC product could create a situation where personal injury or death may occur. Should Buyer purchase or use SCILLC products for any such unintended or unauthorized application, Buyer shall indemnify and hold SCILLC and its officers, employees, subsidiaries, affiliates, and distributors harmless against all claims, costs, damages, and expenses, and reasonable attorney fees arising out of, directly or indirectly, any claim of personal injury or death associated with such unintended or unauthorized use, even if such claim alleges that SCILLC was negligent regarding the design or manufacture of the part. SCILLC is an Equal Opportunity/Affirmative Action Employer. This literature is subject to all applicable copyright laws and is not for resale in any manner.

X-ON Electronics

Largest Supplier of Electrical and Electronic Components

Click to view similar products for [Motor/Motion/Ignition Controllers & Drivers](#) category:

Click to view products by [ON Semiconductor](#) manufacturer:

Other Similar products are found below :

[FSB50550TB2](#) [FSBF15CH60BTH](#) [MSVCPM2-63-12](#) [MSVGW45-14-2](#) [MSVGW54-14-3](#) [MSVGW54-14-5](#) [NTE7043](#) [LA6565VR-TLM-E](#)
[LB11650-E](#) [LB1837M-TLM-E](#) [LB1845DAZ-XE](#) [LC898300XA-MH](#) [SS30-TE-L-E](#) [26700](#) [LV8281VR-TLM-H](#) [BA5839FP-E2](#) [IRAM236-1067A](#) [LA6584JA-AH](#) [LB11847L-E](#) [NCV70501DW002R2G](#) [AH293-PL-B](#) [STK672-630CN-E](#) [TND315S-TL-2H](#) [FNA23060](#) [FSB50250AB](#)
[FNA41060](#) [MSVB54](#) [MSVBTC50E](#) [MSVCPM3-54-12](#) [MSVCPM3-63-12](#) [MSVCPM4-63-12](#) [MSVTA120](#) [FSB50550AB](#)
[NCV70501DW002G](#) [LC898301XA-MH](#) [LV8413GP-TE-L-E](#) [MSVGW45-14-3](#) [MSVGW45-14-4](#) [MSVGW45-14-5](#) [MSVGW54-14-4](#)
[STK984-091A-E](#) [MP6519GQ-Z](#) [LB11651-E](#) [IRSM515-025DA4](#) [LV8127T-TLM-H](#) [MC33812EKR2](#) [NCP81382MNTXG](#) [TDA21801](#)
[LB11851FA-BH](#) [NCV70627DQ001R2G](#)