



ON Semiconductor®

<http://onsemi.com>

LV5068V

Bi-CMOS IC

Low power consumption and high efficiency Step-down Switching Regulator Controller

Overview

LV5068V is 1ch step-down switching regulator. The operation current is about 80 μ A, and low power consumption is achieved.

Functions

- 1ch SBD rectification controller IC
- Maximum value of light load mode current is 80 μ A.
- Built-in OCP circuit with P-by-P method
- When P-by-P is generated continuously, it shifts to the HICCUP operation.
- If connect C-HICCUP to GND pin, then latch-off when over current.
- The oscillatory frequency can be set by the external pin. The oscillatory frequency is 300 kHz to 2.2MHz
- Built-in UVLO, TSD
- Synchronous driving with external signal

Specifications

Maximum Ratings at Ta = 25°C

Parameter	Symbol	Conditions	Ratings	Unit
Input voltage	V _{IN} max		45	V
Allowable pin voltage	PDR,HDRV,RSNS,ILIM,EN,PG		V _{IN}	V
	V _{IN} -PDR		6	V
	REF		6	V
	SS,FB,COMP,RT C-HICCUP,SYNC		REF	V
Allowable power dissipation	Pd max	Specified substrate *1	0.74	W
Operating temperature	Topr		-40 to +85	°C
Storage temperature	Tstg		-55 to +150	°C

*1: Specified substrate 114.3mm×76.1mm×1.6mm³ glass-epoxy

Stresses exceeding Maximum Ratings may damage the device. Maximum Ratings are stress ratings only. Functional operation above the Recommended Operating Conditions is not implied. Extended exposure to stresses above the Recommended Operating Conditions may affect device reliability.

LV5068V

Recommended Operating Conditions at Ta = 25°C

Parameter	Symbol	Conditions	Ratings	Unit
Input voltage range	V _{IN}		4.5 to 40	V

Electrical Characteristics at Ta = 25°C, V_{IN} = 15V

Parameter	Symbol	Conditions	Ratings			Unit
			min	typ	max	
Reference voltage						
Internal reference voltage	V _{ref}		1.241	1.260	1.279	V
Pch drive voltage	V _{PDR}	I _{OUT} =0 to -5mA	V _{IN} -5.5	V _{IN} -5.0	V _{IN} -4.5	V
Saw wave oscillator						
Oscillatory frequency	F _{OSC}	RT=470kΩ	280	330	380	kHz
ON/OFF circuit						
IC start-up voltage	V _{CNT_ON}		1.5		V _{IN}	V
Disable voltage	V _{CNT_OFF}		0		0.3	V
Soft start circuit						
Soft start source current	I _{SS_SC}	EN>1.5V	1.3	2.0	2.7	μA
Soft start sink current	I _{SS_SK}	EN<0.3V, SS=4V	1.0	1.6	2.2	mA
UVLO circuit						
UVLO release voltage	V _{UVLON}	FB=COMP	3.3	3.7	4.1	V
UVLO lock voltage	V _{UVLOF}	FB=COMP	2.5	2.9	3.3	V
Error amplifier						
Input bias current	I _{EA_IN}		-100	-50	100	nA
Error amplifier gain	G _{EA}		100	250	400	μA/V
Output sink current	I _{EA_OSK}	FB=1.75V	-40	-20	-10	μA
Output source current	I _{ES_OSC}	FB=0.75V	10	20	40	μA
Over current limit circuit						
Reference current	I _{LIM1}		48.4	55	61.6	μA
Over current detection comparator offset voltage	V _{LIM_OFS}		-5		+5	mV
RSNS pin input range	V _{RSNS}		V _{IN} -0.175		V _{IN}	V
HICCUP timer start-up cycle	N _L CYCLES			15		cycle
HICCUP comparator threshold voltage	V _{tHIC}		1.2	1.26	1.32	V
HICCUP timer change current	I _{HIC}		1	2	3	μA
PWM comparator						
Maximum On-duty	D max		95			%
Logic output						
Power good "L" sink current	I _{PWRGD_L}	PG=5V	4	5	6	mA
Power good "H" leakage current	I _{PWRGD_H}	PG=5V	0		1	μA
Power good threshold voltage	V _{tPG}		1.0	1.1	1.2	V
Power good hysteresis	V _{PG_H}		40	50	60	mV
Output						
Output on-resistance (High)	R _{ONH}			3		Ω
Output on-resistance (Low)	R _{ONL}			3		Ω
Output on-current (High)	I _{ONH}		500			mA
Output on-current (Low)	I _{ONL}		500			mA
The entire device						
Stand-by current	I _{CCS}	EN<0.3V	0		1	μA
Light load mode consumption current	I _{SLEEP1}	EN>1.5V, No switching	30	55	80	μA
Thermal shutdown	TSD	*2	150	170	190	°C

*2: Design certification

LV5068V

Package Dimensions

unit : mm (typ)

3178B

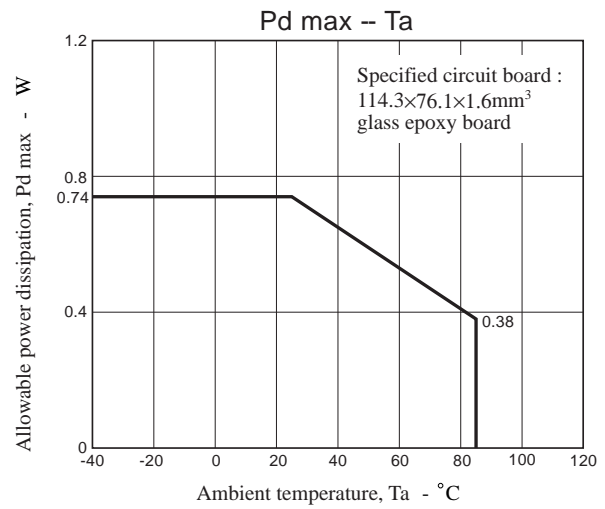
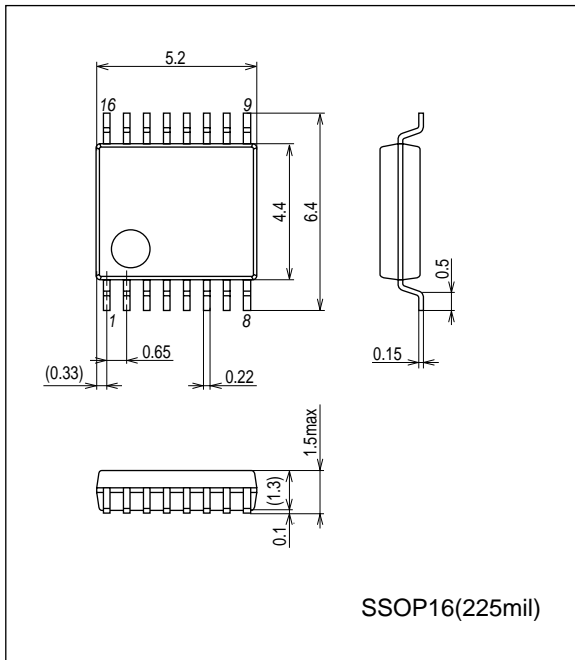

Block Diagram

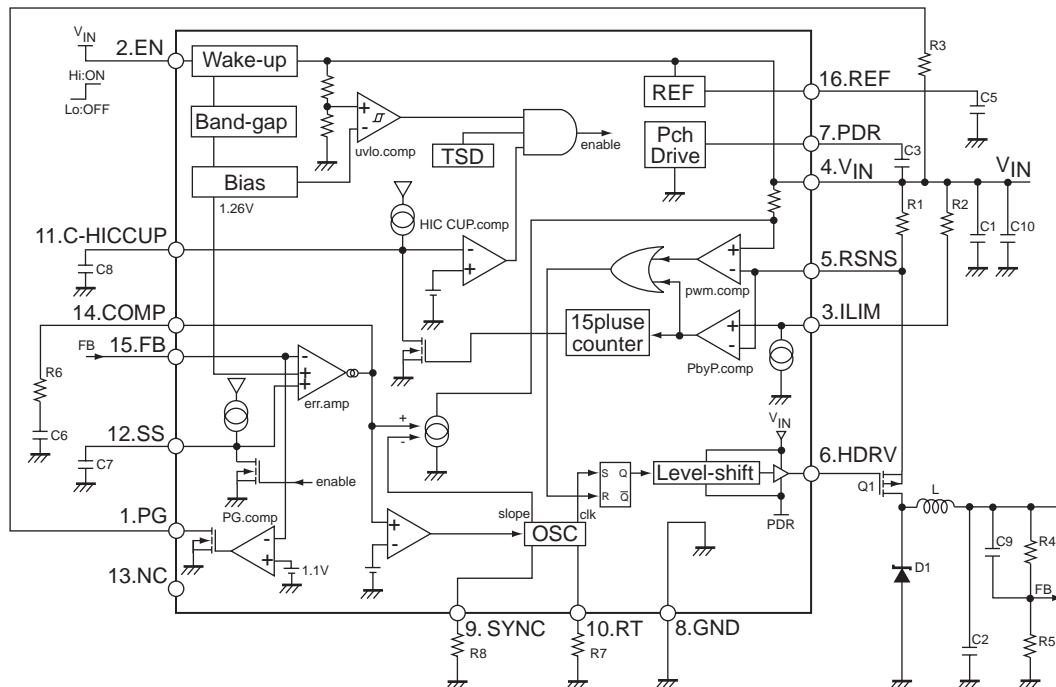

LV5068V

Pin Assignment

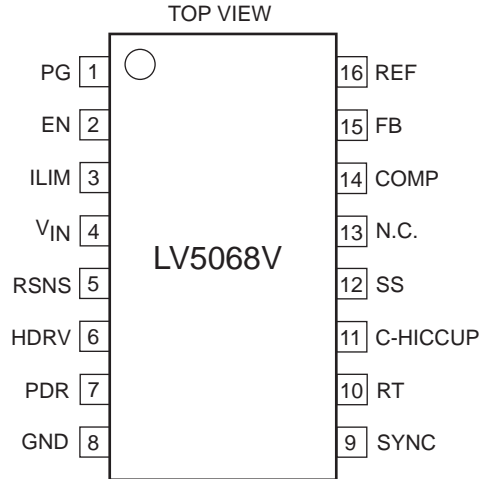

Pin Descriptions

Pin No.	Pin name	Descriptions	Equivalent circuit
1	PG	Power good pin. Connect to open drain of MOS-FET in ICs inside. Setting output voltage to "L", when FB voltage is 1.05V or less	
2	EN	ON/OFF pin	
3	ILIM	For current detection. Sink current is about 55μA. The current limiter comparator works when an external resistor is connected between this pin and V _{IN} , and if the voltage of this resistor is less than the voltage of RSNS then Pch MOS is turned off. This operation is reset each PWM pulse.	
4	V _{IN}	Supply voltage pin. It is observed by the UVLO function. When its voltage becomes 3.7V or more, ICs startup in soft start.	
5	RSNS	Current detection resistor connection pin. Resistor is connected between V _{IN} and this pin, and the current flows to MOSFET are measured.	

Continued on next page.

LV5068V

Continued from preceding page.

Pin No.	Pin name	Descriptions	Equivalent circuit
6	HDRVV	The external high-side MOSFET gate drive pin.	
7	PDR	Gate drive voltage of the external Pch MOSFET. Meanwhile, the bypass capacitor is connected between V_{IN} and this pin.	
8	GND	Ground Pin. Ground pin voltage is reference voltage.	
9	SYNC	Pin of using combined of external synchronous signal input pin	
10	RT	Oscillation frequency setting pin. Resistor is connected between this pin and GND.	
11	C-HICCUP	It is capacitor connection pin for setting re-startup cycle in HICCUP mode. If connect it to GND pin, then latch-off when over current.	
12	SS	Capacitor connection pin for soft start. About $2\mu\text{A}$ current charges the soft start capacitor.	
13	NC	NC pin.	

Continued on next page.

LV5068V

Continued from preceding page.

Pin No.	Pin name	Descriptions	Equivalent circuit
14	COMP	<p>Error Amplifier Output Pin.</p> <p>The phase compensation network is connected between GND pin and COMP pin.</p> <p>Thanks to current-mode control, COMP pin voltage would tell you the output current amplitude. COMP pin is connected internally to an int.comparator which comparators with 0.9V reference. If COMP pin voltage is larger than 0.9V, IC operates in "continuous mode". If COMP pin voltage is smaller than 0.9V, IC operates in "discontinuous mode (low consumption mode)".</p>	
15	FB	<p>Error amplifier reverse input pin.</p> <p>ICs make its voltage keep 1.26V. Output voltage is divided by external resistors and it across FB.</p>	
16	REF	<p>Reference voltage.</p>	

ON Semiconductor and the ON logo are registered trademarks of Semiconductor Components Industries, LLC (SCILLC). SCILLC owns the rights to a number of patents, trademarks, copyrights, trade secrets, and other intellectual property. A listing of SCILLC's product/patent coverage may be accessed at www.onsemi.com/site/pdf/Patent-Marking.pdf. SCILLC reserves the right to make changes without further notice to any products herein. SCILLC makes no warranty, representation or guarantee regarding the suitability of its products for any particular purpose, nor does SCILLC assume any liability arising out of the application or use of any product or circuit, and specifically disclaims any and all liability, including without limitation special, consequential or incidental damages. "Typical" parameters which may be provided in SCILLC data sheets and/or specifications can and do vary in different applications and actual performance may vary over time. All operating parameters, including "Typicals" must be validated for each customer application by customer's technical experts. SCILLC does not convey any license under its patent rights nor the rights of others. SCILLC products are not designed, intended, or authorized for use as components in systems intended for surgical implant into the body, or other applications intended to support or sustain life, or for any other application in which the failure of the SCILLC product could create a situation where personal injury or death may occur. Should Buyer purchase or use SCILLC products for any such unintended or unauthorized application, Buyer shall indemnify and hold SCILLC and its officers, employees, subsidiaries, affiliates, and distributors harmless against all claims, costs, damages, and expenses, and reasonable attorney fees arising out of, directly or indirectly, any claim of personal injury or death associated with such unintended or unauthorized use, even if such claim alleges that SCILLC was negligent regarding the design or manufacture of the part. SCILLC is an Equal Opportunity/Affirmative Action Employer. This literature is subject to all applicable copyright laws and is not for resale in any manner.

X-ON Electronics

Largest Supplier of Electrical and Electronic Components

Click to view similar products for [Switching Controllers](#) category:

Click to view products by [ON Semiconductor](#) manufacturer:

Other Similar products are found below :

[AZ7500EP-E1](#) [NCP1218AD65R2G](#) [NCP1234AD100R2G](#) [NCP1244BD065R2G](#) [NCP1336ADR2G](#) [NCP6153MNTWG](#) [NCP81101BMNTXG](#)
[NCP81205MNTXG](#) [SJE6600](#) [SMBV1061LT1G](#) [SG3845DM](#) [NCP4204MNTXG](#) [NCP6132AMNR2G](#) [NCP81102MNTXG](#)
[NCP81203MNTXG](#) [NCP81206MNTXG](#) [NX2155HCUPTR](#) [UBA2051C](#) [MAX8778ETJ+](#) [NTBV30N20T4G](#) [NCP1240AD065R2G](#)
[NCP1240FD065R2G](#) [NCP1361BABAYSNT1G](#) [NTC6600NF](#) [NCP1230P100G](#) [NCP1612BDR2G](#) [NX2124CSTR](#) [SG2845M](#)
[NCP81101MNTXG](#) [TEA19362T/1J](#) [IFX81481ELV](#) [NCP81174NMNTXG](#) [NCP4308DMTTWG](#) [NCP4308DMNTWG](#) [NCP4308AMTTWG](#)
[NCP1251FSN65T1G](#) [NCP1246BLD065R2G](#) [NTE7154](#) [NTE7242](#) [LTC7852IUFD-1#PBF](#) [LTC7852EUFD-1#PBF](#) [MB39A136PFT-G-BND-ERE1](#) [NCP1256BSN100T1G](#) [LV5768V-A-TLM-E](#) [NCP1365BABCYDR2G](#) [NCP1365AABCYDR2G](#) [MCP1633T-E/MG](#) [NCV1397ADR2G](#)
[NCP1246ALD065R2G](#) [AZ494AP-E1](#)