



ON Semiconductor®

<http://onsemi.com>

LV52206XA

Bi-CMOS IC

Dual channel LED Boost Driver with PWM and 1-Wire Dimming

Overview

The LV52206XA is a high voltage boost driver for LED drive with 2 channels adjustable constant current sources.

Features

- Operating Voltage from 2.7V to 5.5V
- 1-Wire 32 level digital and PWM dimming
- Integrated 43V MOSFET
- 600kHz Switching Frequency

Typical Applications

- LED Display Backlight Control

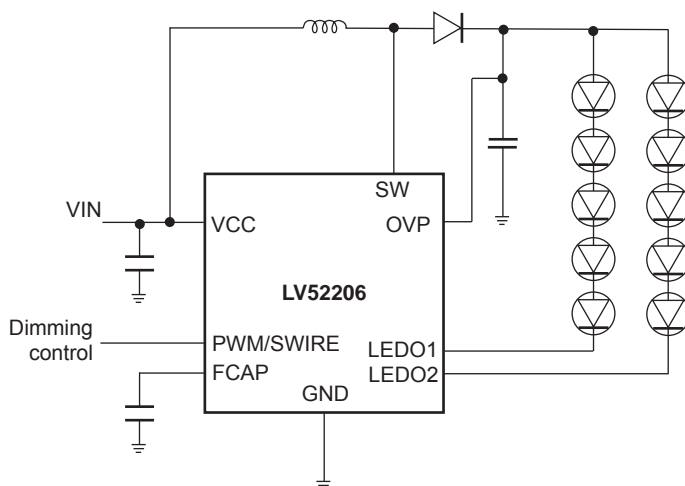

Fig1. 5×2 LED Application

ORDERING INFORMATION

See detailed ordering and shipping information on page 11 of this data sheet.

LV52206XA

Specifications

Absolute Maximum Ratings at $T_a = 25^\circ\text{C}$

Parameter	Symbol	Conditions	Ratings	Unit
Maximum supply voltage	$V_{CC\ max}$	V_{CC}	5.5	V
Maximum pin voltage1	$V1\ max$	SW	43	V
Maximum pin voltage2	$V2\ max$	Other pin	5.5	V
Allowable power dissipation	$Pd\ max$	$T_a = 25^\circ\text{C} *1$	1.30	W
Operating temperature	T_{opr}		-30 to +85	$^\circ\text{C}$
Storage temperature	T_{stg}		-55 to +125	$^\circ\text{C}$

*1 Mounted on a specified board: 70mm×70mm×1.2mm (4 layer glass epoxy)

Caution 1) Absolute maximum ratings represent the values which cannot be exceeded for any length of time.

Caution 2) Even when the device is used within the range of absolute maximum ratings, as a result of continuous usage under high temperature, high current, high voltage, or drastic temperature change, the reliability of the IC may be degraded. Please contact us for the further details.

Stresses exceeding Maximum Ratings may damage the device. Maximum Ratings are stress ratings only. Functional operation above the Recommended Operating Conditions is not implied. Extended exposure to stresses above the Recommended Operating Conditions may affect device reliability.

Recommendation Operating Condition at $T_a = 25^\circ\text{C}$

Parameter	Symbol	Conditions	Ratings	Unit
Supply voltage range1	$V_{CC\ op}$	V_{CC}	2.7 to 5.5	V
PWM frequency	F_{pwm}	PWM MODE	300 to 100k	Hz

Electrical Characteristics Analog block at $T_a = 25^\circ\text{C}$, $V_{CC} = 3.6\text{V}$, unless otherwise specified

Parameter	Symbol	Conditions	Ratings			Unit
			min	typ	max	
Standby current dissipation	I_{CC1}	SHUTDOWN		0	5	μA
DC/DC current dissipation 1	I_{CC2}	$V_{OUT} = 30\text{V}$, $I_{LED} = 20\text{mA}$		1		mA
FB voltage	V_{fb}	$LED01,2=20\text{mA}$		0.25		V
Output current 1	$Io1$	LED0 1 LED0 2	9.5	10	10.5	μA
Output current 2	$Io2$	LED0 1 LED0 2	19	20	21	μA
Output current matching 1	$Iom1$	LED01 LED0 2 LEDISET=10mA	-2	0.3	2	%
Output current matching 2	$Iom2$	LED01 LED0 2 LEDISET=20mA	-2	0.3	2	%
LED01,2 leak current	I_{lk}	LED01 LED02			1	μA
OVP voltage 1	V_{ovp}	OVP	37	38	39	V
SWOUT ON resistance	R_{on}	$I_L = 100\text{mA}$		250		$\text{m}\Omega$
NMOS switch current limit	I_{LIM}			1		A
OSC frequency	F_{osc}			600		kHz
High level input voltage	V_{INH}	SWIRE PWM	1.5		V_{CC}	V
Low level input voltage	V_{INL}	SWIRE PWM	0		0.4	V
Under voltage lockout	V_{uvlo}	V_{IN} falling		2.2		V
SWIRE output voltage for Acknowledge	V_{ack}	$R_{pullup} = 15\text{k}\Omega$			0.4	V

Recommended SWIRE Timing at $T_a = 25^\circ\text{C}$, $V_{CC} = 3.6\text{V}$, unless otherwise specified

Parameter	Symbol	Conditions	Ratings			Unit
			min	typ	max	
SWIRE setup time from shutdown	T_{on}		20			μs
SWIRE mode selectable time	T_{sel}		1		2.2	ms
SWIRE delay time to start digital mode detection	T_{w0}		100			μs
SWIRE low time to switch to digital mode	T_{w1}		260			μs
SWIRE low time to shutdown	T_{off}		8.9			ms

Continued on next page.

LV52206XA

Continued from preceding page.

Parameter	Symbol	Conditions	Ratings			Unit
			min	typ	max	
SWIRE start time for digital mode programming	Tstart		2			μs
SWIRE end time for digital mode programming	Tend		2		360	μs
SWIRE High time of bit 0	Th0	Bit detection = 0	2		180	μs
SWIRE Low time of bit 0	Tl0	Bit detection = 0	Th0 × 2		360	μs
SWIRE High time of bit 1	Th1	Bit detection = 1	Tl1 × 2		360	μs
SWIRE Low time of bit1	Tl1	Bit detection = 1	2		180	μs
DCDC startup delay	Tdel			2		ms
Delay time of Acknowledge	Tackd				2	μs
Duration of Acknowledge	Tack				512	μs

Block Diagram

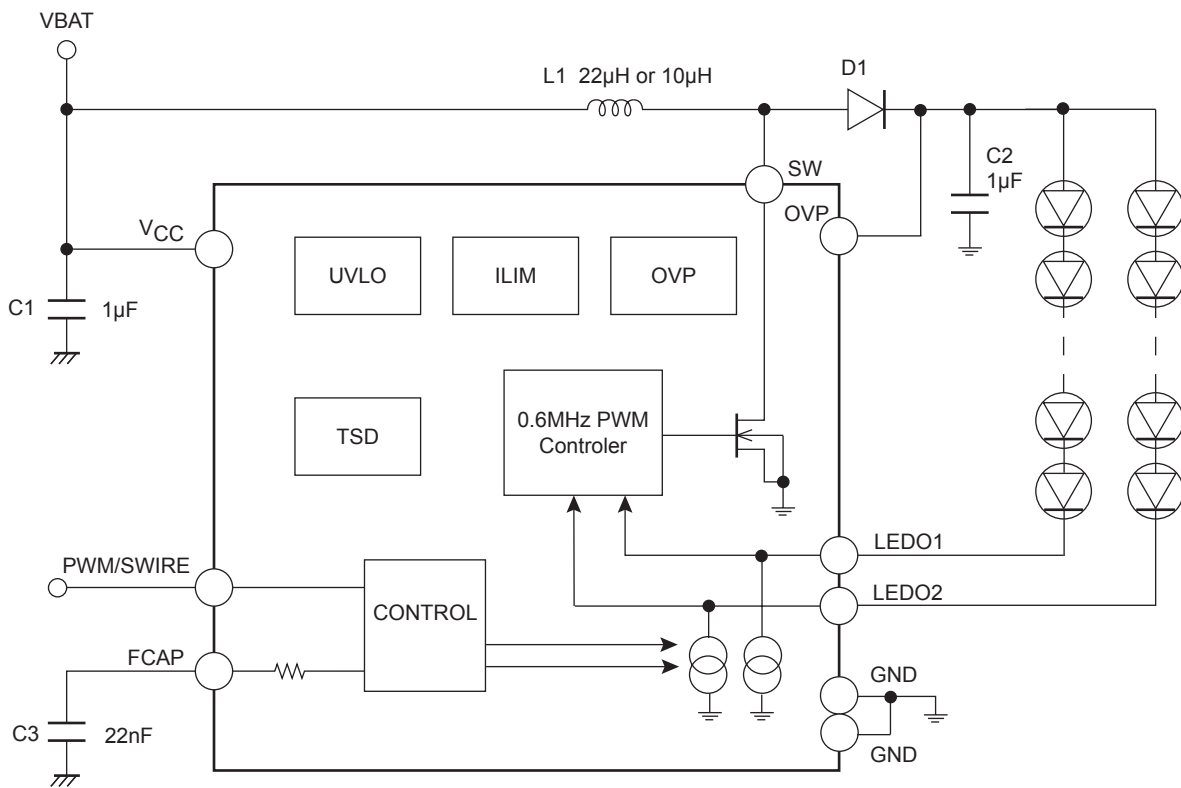

L1: VL3012T-220M49 (TDK) VLS3012T-100M72 (TDK)
 D1: MBR0540T1 (ON semi)
 C2: GRM21BR71H105K (Murata)

Fig.2 Block Diagram

LV52206XA

Pin Function

PIN #	Pin Name	Description
A1	LEDO1	Constant current output _pin1.
A2	FCAP	Filtering capacitor terminal for PWM mode.
A3	VCC	Supply voltage
B1	LEDO2	Constant current output _pin2.
B2	PWM / SWIRE	1-wire control and PWM dimming input (active High).
B3	OVP	Output voltage sense connection for over voltage sensing.
C1	GND	Ground.
C2	GND	Ground.
C3	SW	Switch pin. Drain of the internal power FET.

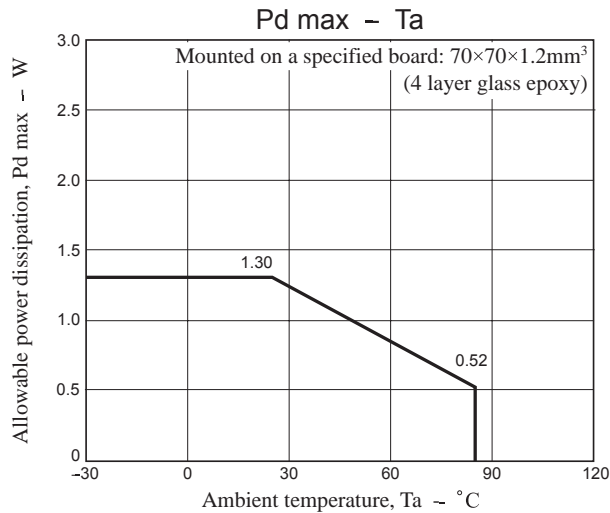

Dimming Mode Selection

Dimming Mode is selected by a specific pattern of the SWIRE within Tsel (1ms) from the startup of the device every time. In order to startup the device, the SWIRE must keep high for longer than Ton.

PWM Mode

The dimming mode is set to PWM mode when it is not recognized as a digital mode within Tsel. To enter Digital Mode, the SWIRE is required keeping in low state for Tw1 (See Fig.4). If the PWM frequency is used faster than 6.6kHz, the dimming mode is set to PWM mode only. But slower than 6.6kHz, it is necessary to avoid entering the digital mode condition, such as SWIRE keeps high for longer than Tsel. PWM is enabled after Tdel from Tsel.

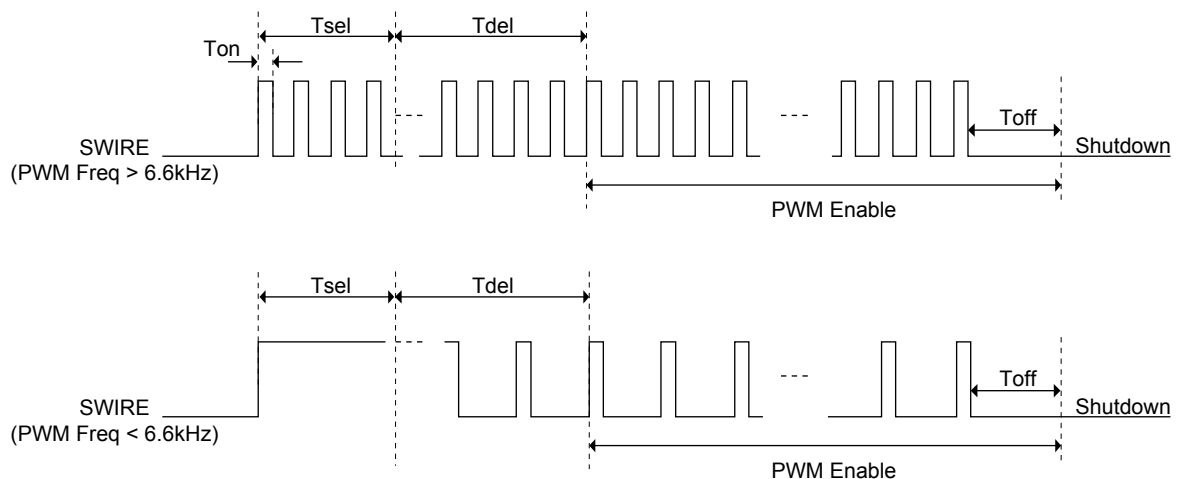

Fig3. SWIRE Timing Diagram in PWM mode

Digital Mode

To enter Digital Mode, SWIRE should be taken high for more than T_{w0} (100 μ s) from the first rising edge and keep low state for T_{w1} (260 μ s) before T_{sel} (1ms).

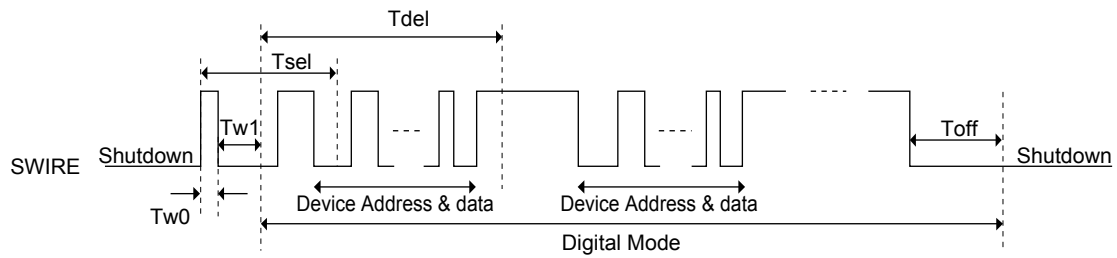

Fig4. SWIRE Timing Diagram in Digital mode

It is required sending the device address byte and the data byte to select V_{FB} . The bit detection is determined by the ratio of T_h and T_l (See Fig6). The start condition for the bit transmission required SWIRE high for at least T_{start} . The end condition is required SWIRE low for at least T_{end} . When data is not being transferred, SWIRE is set in the “H” state. These registers are initialized with POR (Power On Reset).

In the LV52206XA, the device address(DA7 to DA0) is specified as “01110011”. AKct is setting for the acknowledge response. If the device address and the data byte are transferred on $AKct=1$, the ACK signal is sent from the receive side to the send side. The acknowledge signal is issued when SWIRE on the send side is released and SWIRE on the receive side is set to low state.

	Register	BIT	Description
Device Address	DA7	7	0
	DA6	6	1
	DA5	5	1
	DA4	4	1
	DA3	3	0
	DA2	2	0
	DA1	1	1
	DA0	0	1

Table1. Device Address Description

	Register	BIT	Description
Data	AKct	7	0 = Acknowledge disabled 1 = Acknowledge enabled
	A1	6	Address bit1
	A0	5	Address bit0
	D4	4	Data bit 4
	D3	3	Data bit 3
	D2	2	Data bit 2
	D1	1	Data bit 1
	D0	0	Data bit 0

Table2. Data Description

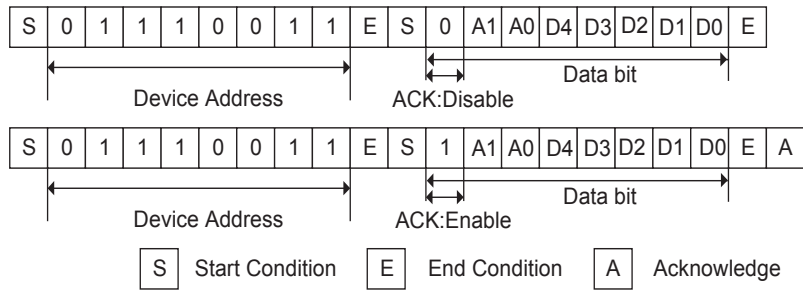

Fig5. Example of writing data

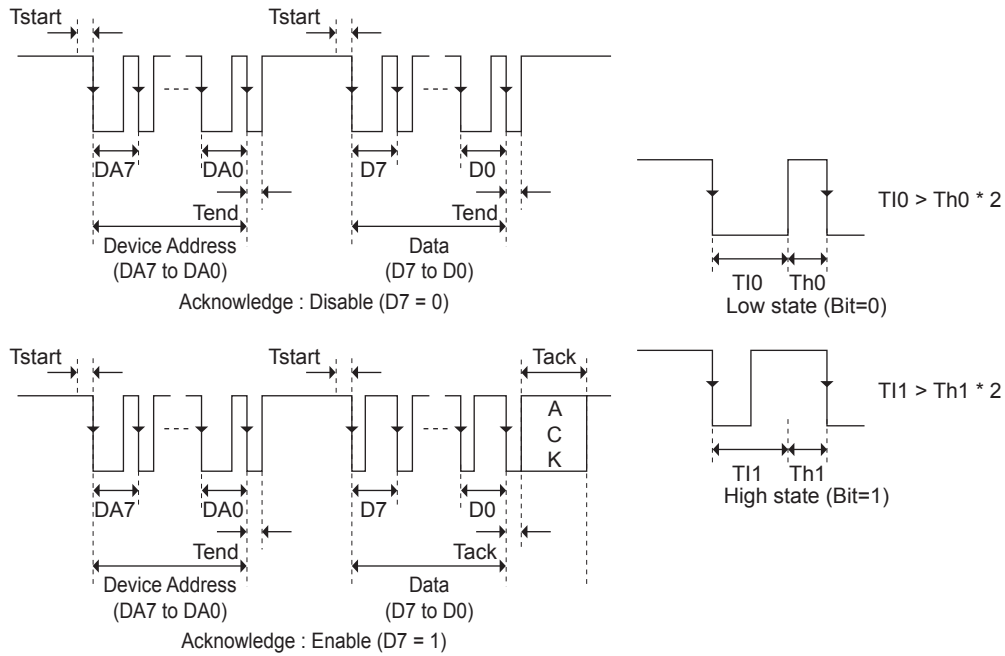

Fig6.Bit detection Diagram

LV52206XA

Table3

LED Current setting Address=00

	A1	A0	D4	D3	D2	D1	D0	LED Current(mA)
0	0	0	0	0	0	0	0	0
1	0	0	0	0	0	0	1	0.5
2	0	0	0	0	0	1	0	1
3	0	0	0	0	0	1	1	1.5
4	0	0	0	0	1	0	0	2
5	0	0	0	0	1	0	1	2.5
6	0	0	0	0	1	1	0	3
7	0	0	0	0	1	1	1	3.5
8	0	0	0	1	0	0	0	4
9	0	0	0	1	0	0	1	5
10	0	0	0	1	0	1	0	6
11	0	0	0	1	0	1	1	7
12	0	0	0	1	1	0	0	8
13	0	0	0	1	1	0	1	9
14	0	0	0	1	1	1	0	10
15	0	0	0	1	1	1	1	11
16	0	0	1	0	0	0	0	12
17	0	0	1	0	0	0	1	13
18	0	0	1	0	0	1	0	14
19	0	0	1	0	0	1	1	15
20	0	0	1	0	1	0	0	16
21	0	0	1	0	1	0	1	17
22	0	0	1	0	1	1	0	18
23	0	0	1	0	1	1	1	19
24	0	0	1	1	0	0	0	20
25	0	0	1	1	0	0	1	21
26	0	0	1	1	0	1	0	22
27	0	0	1	1	0	1	1	23
28	0	0	1	1	1	0	0	24
29	0	0	1	1	1	0	1	25
30	0	0	1	1	1	1	0	26
31	0	0	1	1	1	1	1	27

*Default

Table4

OVP setting Address=01

A1	A0	D4	D3	D2	D1	D0	OVP(V)
0	1	0	0	0	0	0	38
0	1	0	0	0	0	1	41

*Default

Table5

LEDOUT setting Adress=10

A1	A0	D4	D3	D2	D1	D0	LEDO1	LEDO2
1	0	0	0	0	0	0	ON	ON
1	0	0	0	0	0	1	ON	OFF
1	0	0	0	0	1	0	OFF	ON

*Default

Start up and Shutdown

The device becomes enabled when SWIRE is initially taken high. The dimming mode is determined within Tsel and the boost converter start up after Tdel. To place the device into shutdown mode, the SWIRE must be held low for Toff.

PWM MODE

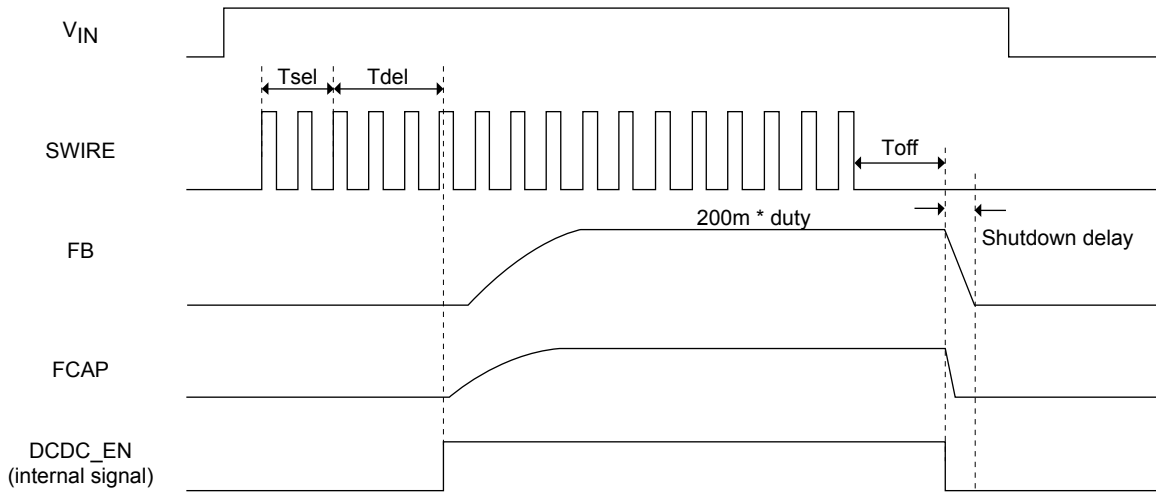

Digital MODE

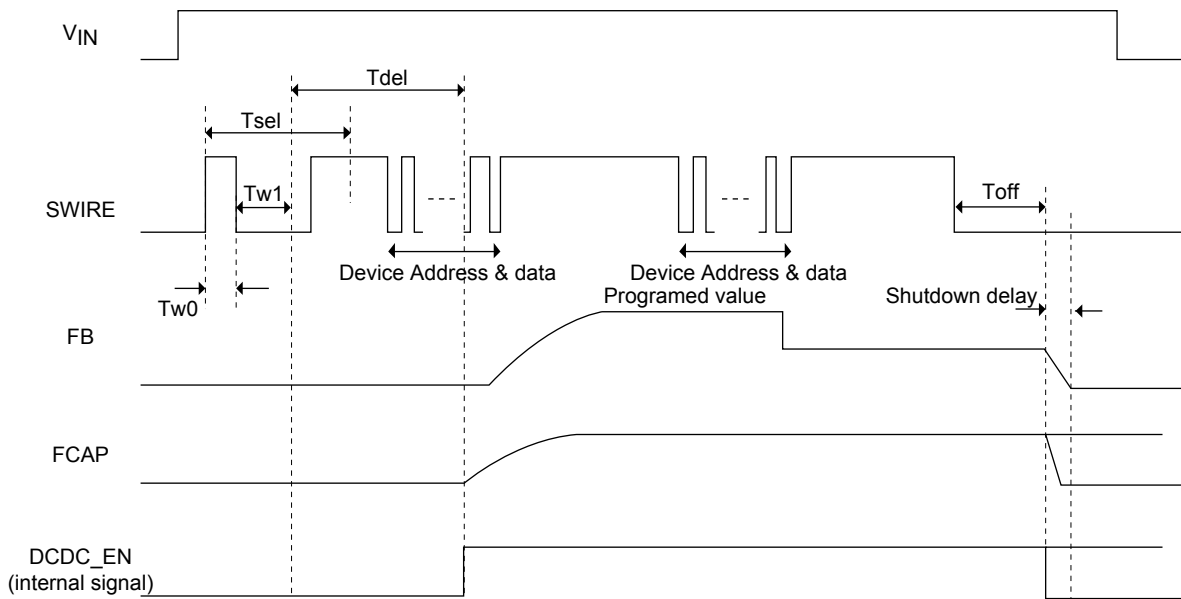

Fig7.Start up and shutdown diagram

Open LED Protection

If OVP terminal voltage exceeds a threshold V_{ovp} (38V typ) and LEDO terminal voltage less than 0.05V for 8 cycles, boost converter enters shutdown mode. In order to restart the IC, It is necessary to start it again from a shut down condition.

Over Current Protection

Current limit value for built-in power MOS is around 1A. The power MOS is turned off for each switching cycle when peak current through it exceeds the limit value.

Under Voltage Lock Out (UVLO)

UVLO operation works when V_{IN} terminal voltage is below 2.2V.

Thermal Shutdown

When chip temperature is too high, boost converter is stopped.

Application Circuit Diagram

10 LED Application
5x2

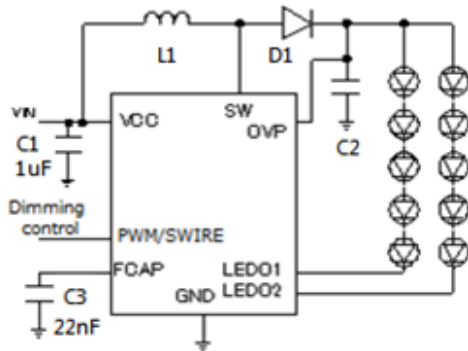

11 LED Application
11x1

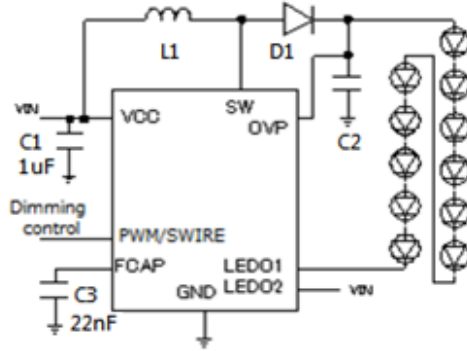

12 LED Application
6x2

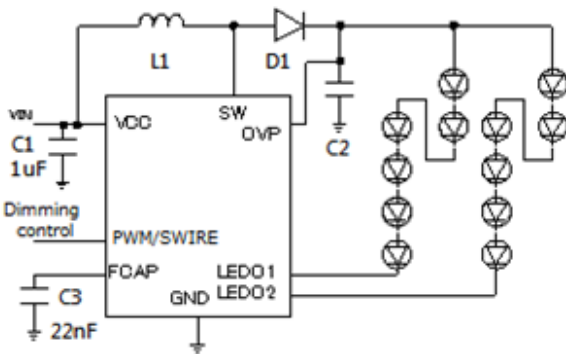

14 LED Application
7x2

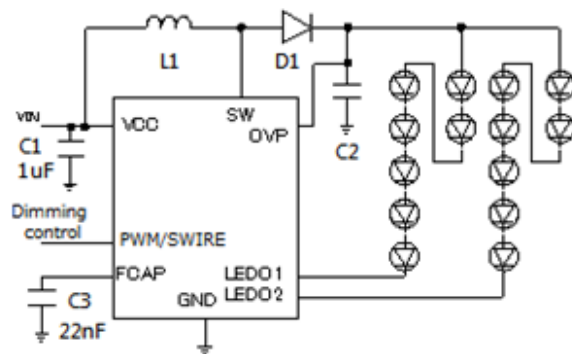

L1:VLS3012E-220M(TDK), VLF504015MT-220M (TDK)
 D1:MBR0540T1 (ON semi), NSR05F40 (ONsemi)
 C2:GRM21BR71H105K(Murata), C1608X5R1H105K (TDK)

Fig8. Various application circuit diagram

LV52206XA

Typical Characteristics ($V_{IN} = 3.6V$, $L = 22\mu H$, $T = 25^{\circ}C$, unless otherwise specified)

Efficiency vs Output Current

MODE=Digital

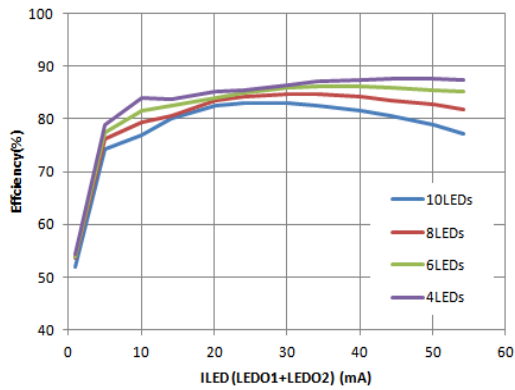

LEDO Current vs. DATA

Mode=Digital, LEDO1.LEDO2=0.5V

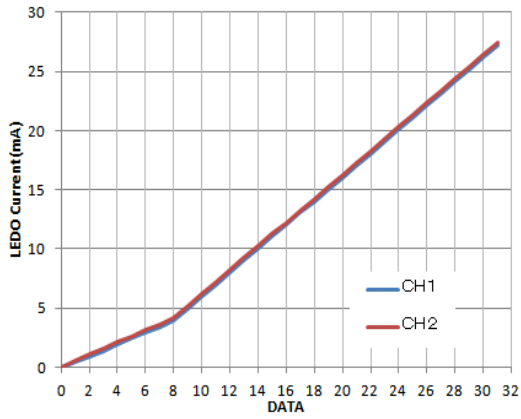

LEDO Current vs. PWM Duty

Mode=PWM, 10kHz, LEDO1.LEDO2=0.5V

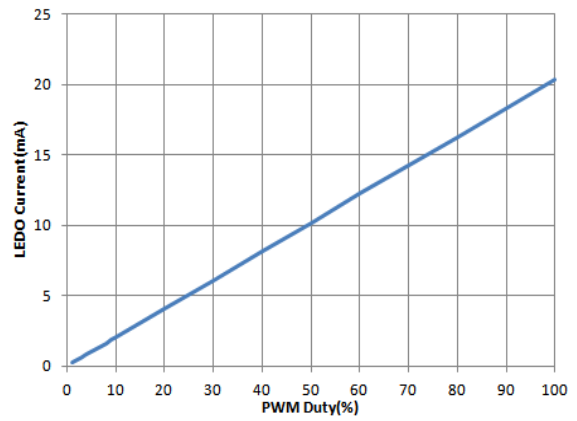

I_{CC} vs V_{IN}

MODE=PWM, Duty=100% 10LED,

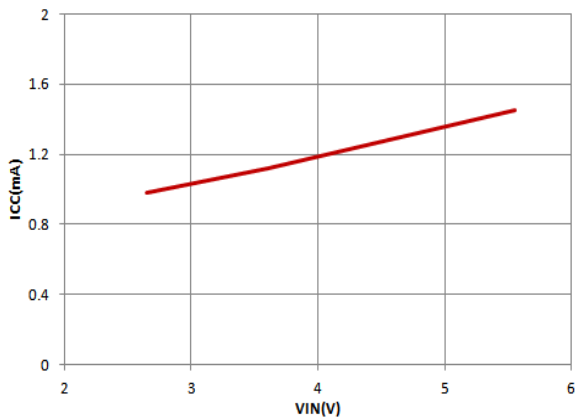

Frequency vs V_{IN}

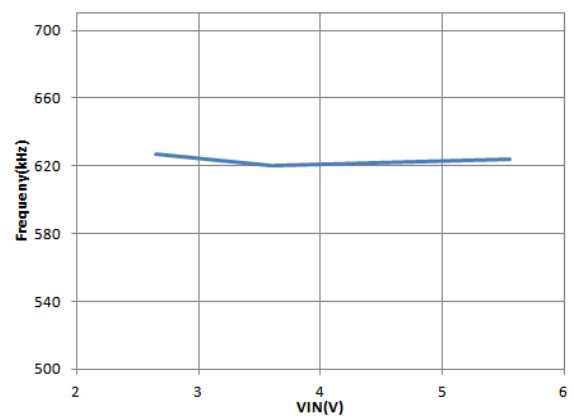

ON Semiconductor and the ON logo are registered trademarks of Semiconductor Components Industries, LLC (SCILLC). SCILLC owns the rights to a number of patents, trademarks, copyrights, trade secrets, and other intellectual property. A listing of SCILLC's product/patent coverage may be accessed at www.onsemi.com/site/pdf/Patent-Marking.pdf. SCILLC reserves the right to make changes without further notice to any products herein. SCILLC makes no warranty, representation or guarantee regarding the suitability of its products for any particular purpose, nor does SCILLC assume any liability arising out of the application or use of any product or circuit, and specifically disclaims any and all liability, including without limitation special, consequential or incidental damages. "Typical" parameters which may be provided in SCILLC data sheets and/or specifications can and do vary in different applications and actual performance may vary over time. All operating parameters, including "Typicals" must be validated for each customer application by customer's technical experts. SCILLC does not convey any license under its patent rights nor the rights of others. SCILLC products are not designed, intended, or authorized for use as components in systems intended for surgical implant into the body, or other applications intended to support or sustain life, or for any other application in which the failure of the SCILLC product could create a situation where personal injury or death may occur. Should Buyer purchase or use SCILLC products for any such unintended or unauthorized application, Buyer shall indemnify and hold SCILLC and its officers, employees, subsidiaries, affiliates, and distributors harmless against all claims, costs, damages, and expenses, and reasonable attorney fees arising out of, directly or indirectly, any claim of personal injury or death associated with such unintended or unauthorized use, even if such claim alleges that SCILLC was negligent regarding the design or manufacture of the part. SCILLC is an Equal Opportunity/Affirmative Action Employer. This literature is subject to all applicable copyright laws and is not for resale in any manner.

X-ON Electronics

Largest Supplier of Electrical and Electronic Components

Click to view similar products for [LED Lighting Drivers](#) category:

Click to view products by [ON Semiconductor](#) manufacturer:

Other Similar products are found below :

[LV5235V-MPB-H](#) [MB39C602PNF-G-JNEFE1](#) [MIC2871YMK-T5](#) [AL1676-10BS7-13](#) [AL1676-20AS7-13](#) [AP5726WUG-7](#) [ICL8201](#)
[IS31BL3228B-UTLS2-TR](#) [IS31BL3506B-TTLS2-TR](#) [AL3157F-7](#) [AP5725FDCG-7](#) [AP5726FDCG-7](#) [LV52204MTTBG](#) [AP5725WUG-7](#)
[STP4CMPQTR](#) [NCL30086BDR2G](#) [CAT4004BHU2-GT3](#) [LV52207AXA-VH](#) [AP1694AS-13](#) [TLE4242EJ](#) [AS3688](#) [IS31LT3172-GRLS4-TR](#)
[TLD2311EL](#) [KTD2694EDQ-TR](#) [KTZ8864EJAA-TR](#) [IS32LT3174-GRLA3-TR](#) [MP2488DN-LF-Z](#) [NLM0010XTSA1](#) [AL1676-20BS7-13](#)
[ZXLD1370QESTTC](#) [MPQ7220GF-AEC1-P](#) [MPQ7220GR-AEC1-P](#) [MPQ4425BGJ-AEC1-P](#) [MPQ7220GF-AEC1-Z](#) [MPQ7220GR-AEC1-Z](#)
[MPQ4425BGJ-AEC1-Z](#) [NCL30486A2DR2G](#) [IS31FL3737B-QFLS4-TR](#) [IS31FL3239-QFLS4-TR](#) [KTD2058EUAC-TR](#) [KTD2037EWE-TR](#)
[DIO5662ST6](#) [IS31BL3508A-TTLS2-TR](#) [KTD2026BEWE-TR](#) [MAX20052CATC/V+](#) [MAX25606AUP/V+](#) [BD6586MUV-E2](#) [BD9206EFV-E2](#) [BD9416FS-E2](#) [LYT4227E](#)