



ON Semiconductor®

<http://onsemi.com>

# LV5609V

Bi-CMOS LSI

## Vertical Clock Driver for CCD

### Overview

The LV5609V is vertical clock driver for CCD.

### Functions

- Ternary output ×2ch
- Binary output ×2ch
- SHT output ×1ch
- Output ON resistance : 30Ω typ

### Specifications

**Absolute Maximum Ratings** at  $T_a = 25^\circ\text{C}$ ,  $V_{SS} = V_M = 0\text{V}$

Parameter	Symbol	Conditions	Ratings	Unit
Maximum supply voltage	$V_{DD}$ max		6	V
	VH max		20	V
	VL max		-10	V
	VH-VL max		24	V
Allowable power dissipation	$P_d$ max	with specified substrate *	0.67	W
Operating temperature	$T_{opr}$		-20 to +80	°C
Storage temperature	$T_{stg}$		-40 to +125	°C

\* : Specified substrate : 114.3×76.1×1.6mm<sup>3</sup>, glass epoxy board

Stresses exceeding Maximum Ratings may damage the device. Maximum Ratings are stress ratings only. Functional operation above the Recommended Operating Conditions is not implied. Extended exposure to stresses above the Recommended Operating Conditions may affect device reliability.

**Allowable Operating Ratings** at  $T_a = 25^\circ\text{C}$ ,  $V_{SS} = V_M = 0\text{V}$

Parameter	Symbol	Conditions	Ratings			Unit
			min	typ	max	
Supply voltage	$V_{DD}$		2.0	3.3	5.5	V
	VH			15	17	V
	VL		-8.5	-7.5	-4	V
	VH-VL				23.5	V
CMOS input High voltage	$V_{INH}$		$0.8V_{DD}$		$V_{DD}$	V
CMOS input Low voltage	$V_{INL}$		-0.1		0.4	V

# LV5609V

**Electrical Characteristics** at  $T_a = 25^\circ\text{C}$ ,  $V_{DD} = 3.3\text{V}$ ,  $V_{SS} = 0\text{V}$ ,  $V_H = 15\text{V}$ ,  $V_L = -7.5\text{V}$ ,  $V_M = 0\text{V}$ ,  
Unless otherwise specified

Parameter	Symbol	Conditions	Ratings			Unit
			min	typ	max	
Static current drain	$I_{DD}$	$V_{DD}$ pin			1	$\mu\text{A}$
	$I_H$	$V_H$ pin			10	$\mu\text{A}$
	$I_L$	$V_L$ pin			1	$\mu\text{A}$
Dynamic current drain	$I_{DD}$	$V_{DD}$ pin See *1 and *2.			1	$\text{mA}$
	$I_H$	$V_H$ pin See *1 and *2.		2.4	4.5	$\text{mA}$
	$I_L$	$V_L$ pin See *1 and *2.		3	5	$\text{mA}$
Output ON resistance	$R_L$	$I_O = +10\text{mA}$		20	30	$\Omega$
	$R_M$	$I_O = \pm 10\text{mA}$		30	45	$\Omega$
	$R_H$	$I_O = -10\text{mA}$		30	40	$\Omega$
	$R_{SHT}$	$I_O = -10\text{mA}$		30	40	$\Omega$
Propagation delay time	$T_{PLM}$	No load			200	$\text{ns}$
	$T_{PMH}$	No load			200	$\text{ns}$
	$T_{PLH}$	No load			200	$\text{ns}$
	$T_{PML}$	No load			200	$\text{ns}$
	$T_{PHM}$	No load			200	$\text{ns}$
	$T_{PHL}$	No load			200	$\text{ns}$
Rise time	$T_{TLM}$	$V_L \rightarrow V_M$ V1, V3 See *1.			800	$\text{ns}$
		$V_L \rightarrow V_M$ V2, V4 See *1.			800	$\text{ns}$
	$T_{TMH}$	$V_M \rightarrow V_L$ V1, V3 See *1.			800	$\text{ns}$
	$T_{TLH}$	$V_L \rightarrow V_H$ SHT See *1.			200	$\text{ns}$
Fall time	$T_{TML}$	$V_M \rightarrow V_L$ V1, V3 See *1.			800	$\text{ns}$
		$V_M \rightarrow V_L$ V2, V4 See *1.			800	$\text{ns}$
	$T_{THM}$	$V_H \rightarrow V_M$ V1, V3 See *1.			800	$\text{ns}$
	$T_{THL}$	$V_H \rightarrow V_L$ SHT See *1.			200	$\text{ns}$

\*1 : Refer to the CCD equivalent load shown below.

\*2 : Refer to the timing waveform on Page 7.

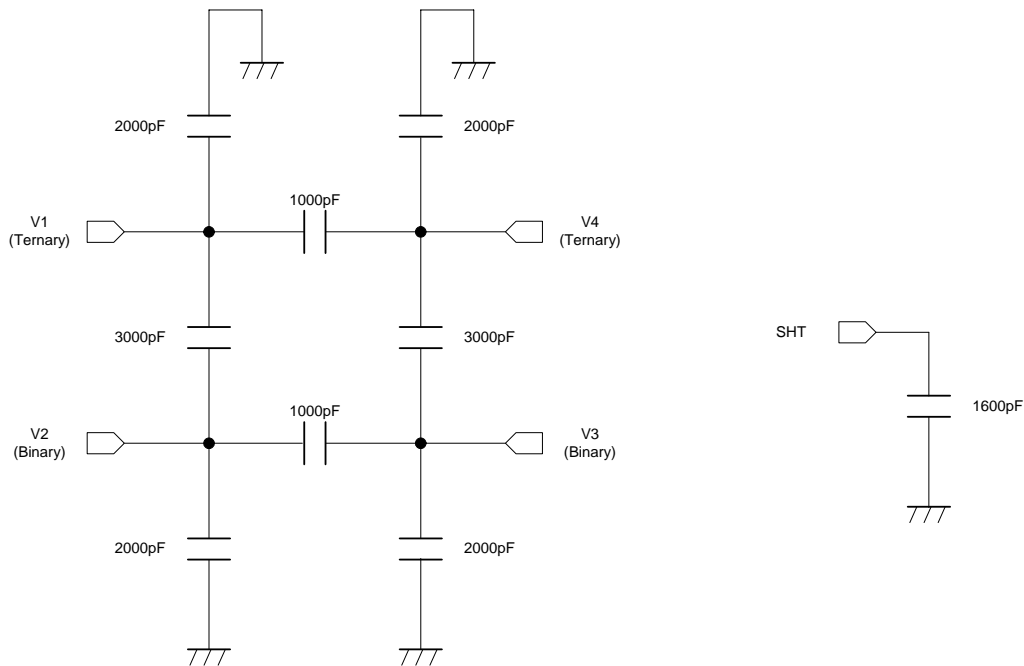

**Package Dimensions**

unit : mm (typ)  
3179C

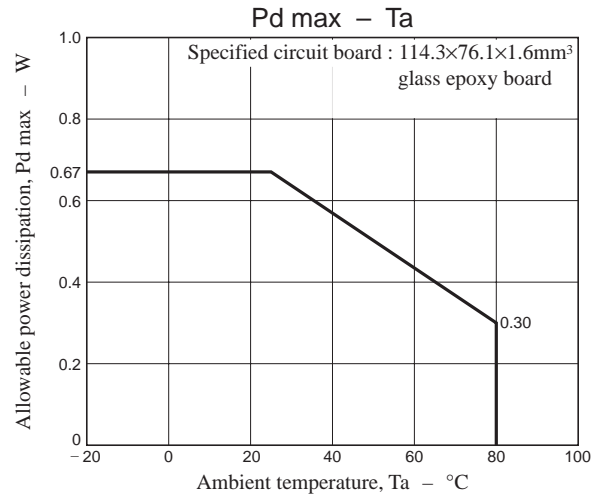
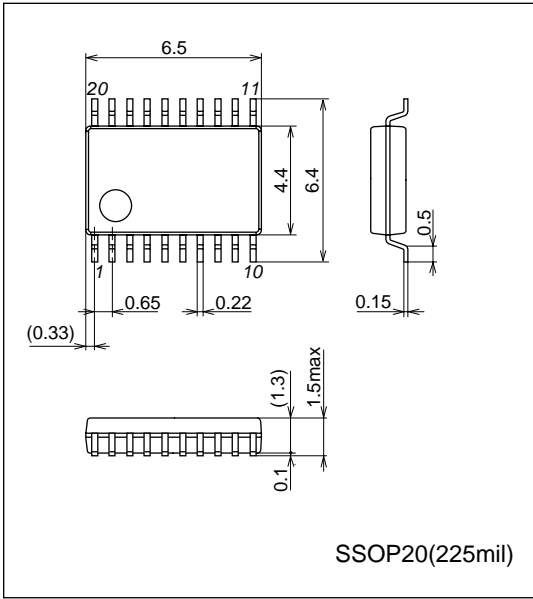

# LV5609V

## Pin Assignment

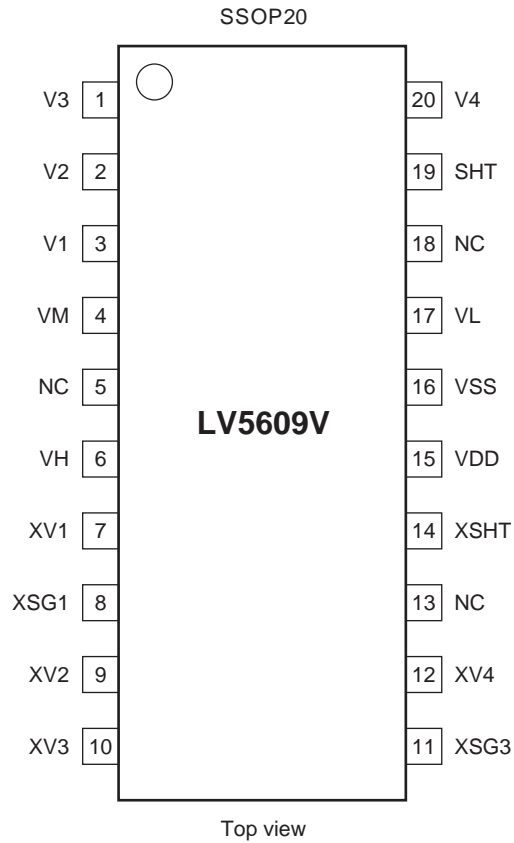

## Pin Function

Pin No.	Name	Mode
1	V3	Level shift output (ternary VH, VM, VL)
2	V2	Level shift output (binary VM, VL)
3	V1	Level shift output (ternary VH, VM, VL)
4	VM	GND for output
5	NC	
6	VH	Hi power supply (15V system) for output
7	XV1	V1 transfer pulse input
8	XSG1	V1 read pulse input
9	XV2	V2 transfer pulse input
10	XV3	V3 transfer pulse input
11	XSG3	V3 read pulse input
12	XV4	V4 transfer pulse input
13	NC1	
14	XSHT	SHT pulse input
15	V <sub>DD</sub>	Power supply (3.3V system) for input buffer
16	V <sub>SS</sub>	GND for input buffer
17	VL	LO power supply (-7.5V system) for output
18	NC	
19	SHT	Level shift output (binary VH, VL)
20	V4	Level shift output (ternary VM, VL)

# LV5609V

## Block Diagram

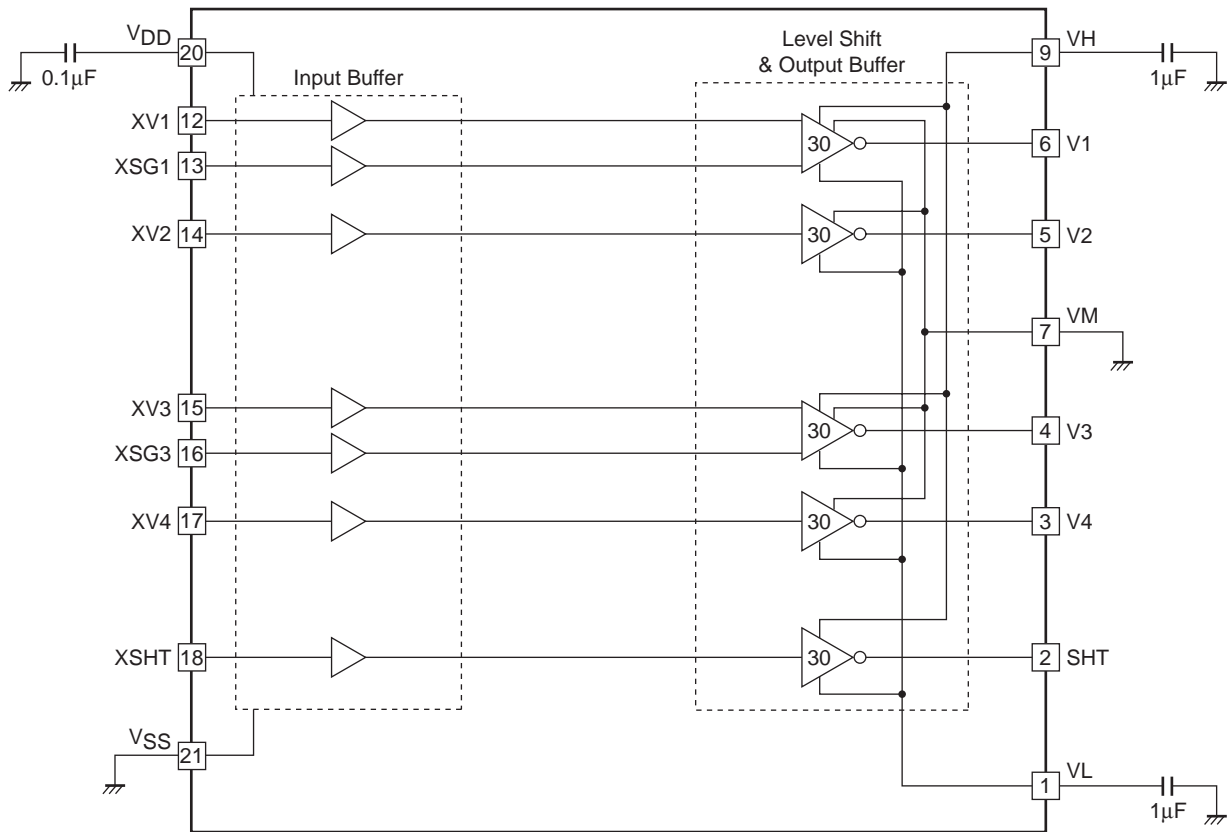

## Logical Function Table

Input				Output		
XV1 XV3	XSG1 XSG3	XV2 XV4	XSHT	V1 V3	V2 V4	SHT
L	L	X	X	VH	X	X
L	H	X	X	VM	X	X
H	L	X	X	VL	X	X
H	H	X	X	VL	X	X
X	X	L	X	X	VM	X
X	X	H	X	X	VL	X
X	X	X	L	X	X	VH
X	X	X	H	X	X	VL

# LV5609V

## Timing Chart

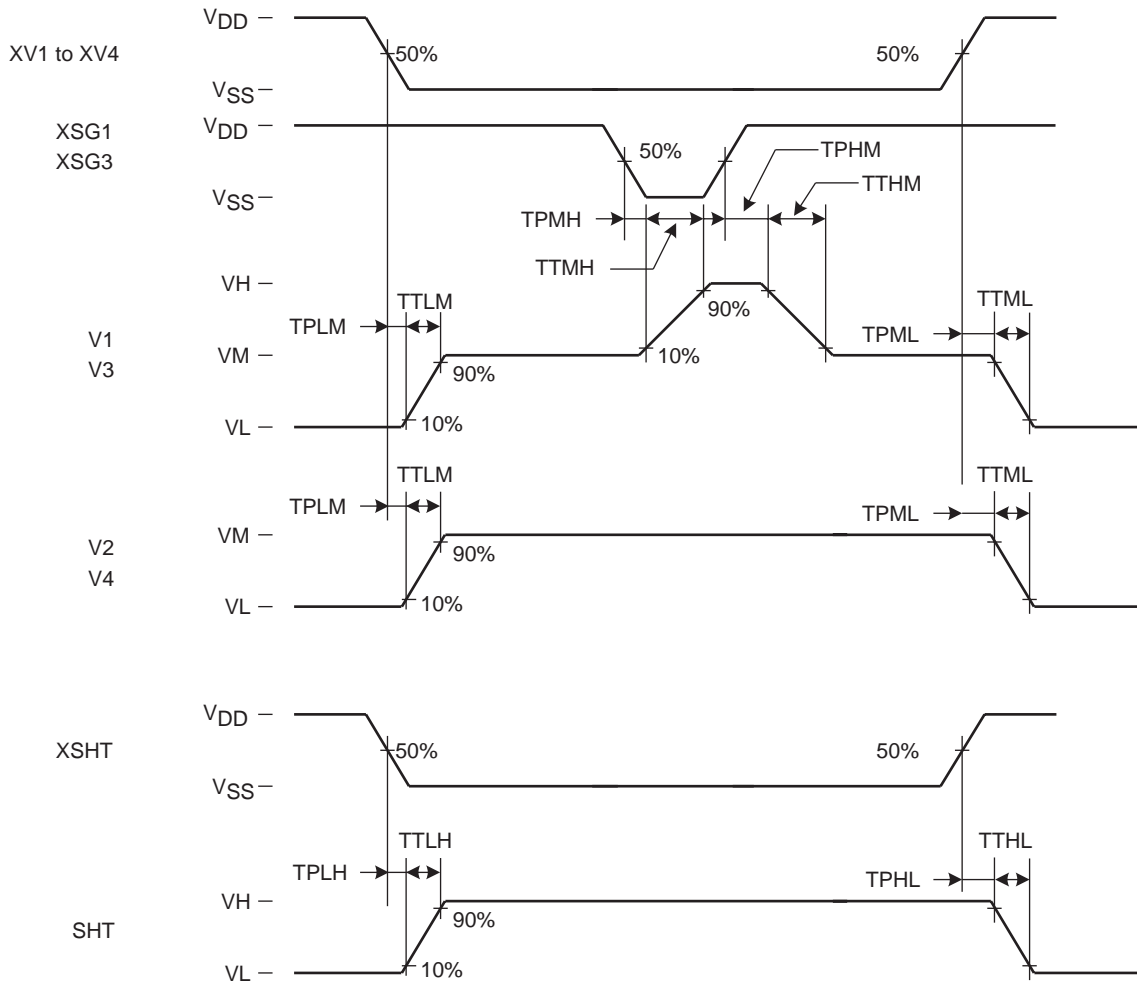

CCD Equivalent Load Measurement Timing Waveform

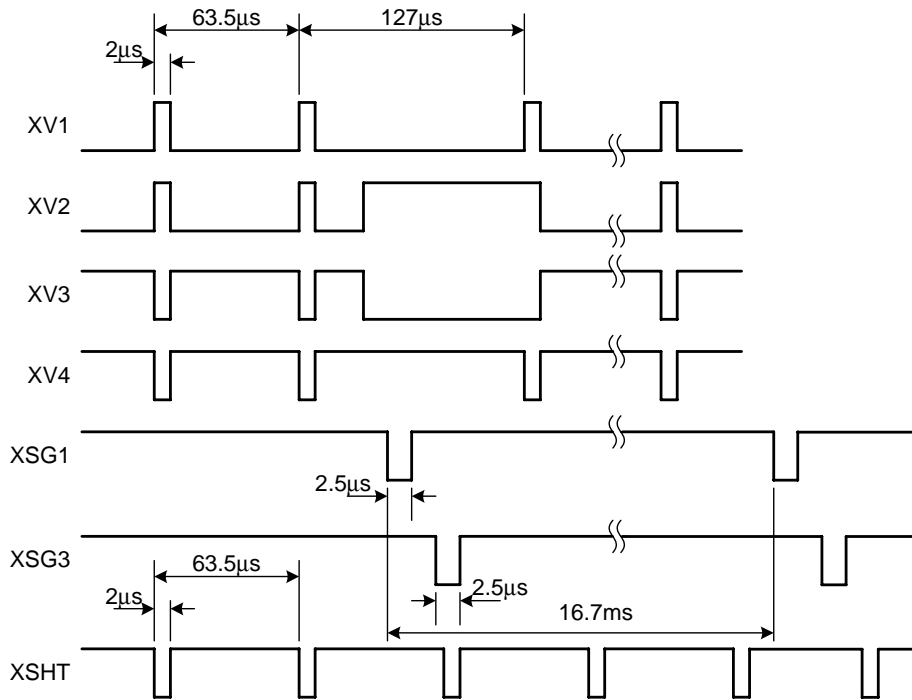

Enlarged View of overlapped portion

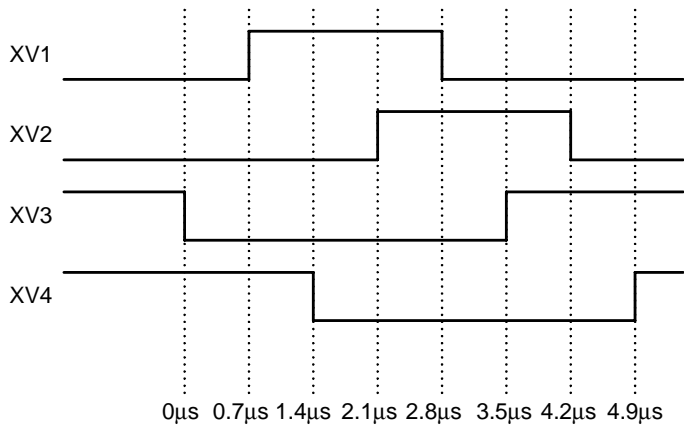

ON Semiconductor and the ON logo are registered trademarks of Semiconductor Components Industries, LLC (SCILLC). SCILLC owns the rights to a number of patents, trademarks, copyrights, trade secrets, and other intellectual property. A listing of SCILLC's product/patent coverage may be accessed at [www.onsemi.com/site/pdf/Patent-Marking.pdf](http://www.onsemi.com/site/pdf/Patent-Marking.pdf). SCILLC reserves the right to make changes without further notice to any products herein. SCILLC makes no warranty, representation or guarantee regarding the suitability of its products for any particular purpose, nor does SCILLC assume any liability arising out of the application or use of any product or circuit, and specifically disclaims any and all liability, including without limitation special, consequential or incidental damages. "Typical" parameters which may be provided in SCILLC data sheets and/or specifications can and do vary in different applications and actual performance may vary over time. All operating parameters, including "Typicals" must be validated for each customer application by customer's technical experts. SCILLC does not convey any license under its patent rights nor the rights of others. SCILLC products are not designed, intended, or authorized for use as components in systems intended for surgical implant into the body, or other applications intended to support or sustain life, or for any other application in which the failure of the SCILLC product could create a situation where personal injury or death may occur. Should Buyer purchase or use SCILLC products for any such unintended or unauthorized application, Buyer shall indemnify and hold SCILLC and its officers, employees, subsidiaries, affiliates, and distributors harmless against all claims, costs, damages, and expenses, and reasonable attorney fees arising out of, directly or indirectly, any claim of personal injury or death associated with such unintended or unauthorized use, even if such claim alleges that SCILLC was negligent regarding the design or manufacture of the part. SCILLC is an Equal Opportunity/Affirmative Action Employer. This literature is subject to all applicable copyright laws and is not for resale in any manner.



## X-ON Electronics

Largest Supplier of Electrical and Electronic Components

*Click to view similar products for [Clock Drivers & Distribution](#) category:*

*Click to view products by [ON Semiconductor](#) manufacturer:*

Other Similar products are found below :

[8501BYLF](#) [P9090-0NLGI8](#) [854110AKILF](#) [83210AYLF](#) [NB6VQ572MMNG](#) [HMC6832ALP5LETR](#) [RS232-S5](#) [6ES7390-1AF30-0AA0](#)  
[CDCVF2505IDRQ1](#) [NB7L572MNR4G](#) [SY100EP33VKG](#) [HMC7043LP7FETR](#) [ISPPAC-CLK5520V-01T100C](#) [EC4P-221-MRXD1](#)  
[6EP1332-1SH71](#) [6ES7211-1AE40-0XB0](#) [6ES7223-1PH32-0XB0](#) [AD246JN](#) [AD246JY](#) [AD9510BCPZ](#) [AD9510BCPZ-REEL7](#) [AD9511BCPZ](#)  
[AD9511BCPZ-REEL7](#) [AD9512BCPZ](#) [AD9512UCPZ-EP](#) [AD9514BCPZ](#) [AD9514BCPZ-REEL7](#) [AD9515BCPZ](#) [AD9515BCPZ-REEL7](#)  
[AD9572ACPZLVD](#) [AD9572ACPZPEC](#) [AD9513BCPZ-REEL7](#) [ADCLK950BCPZ-REEL7](#) [ADCLK950BCPZ](#) [AD9553BCPZ](#) [HMC940LC4B](#)  
[HMC6832ALP5LE](#) [CSPUA877ABVG8](#) [9P936AFLFT](#) [49FCT3805ASOG](#) [49FCT3805EQGI](#) [49FCT805CTQG](#) [74FCT3807ASOG](#)  
[74FCT3807EQGI](#) [74FCT388915TEPYG](#) [853S012AKILF](#) [853S013AMILF](#) [853S058AGILF](#) [8V79S680NLGI](#) [ISPPAC-CLK5312S-01TN48I](#)